

J. F. MIXON.

SAW HANDLE.

APPLICATION FILED OCT. 12, 1909.

986,487.

Patented Mar. 14, 1911.

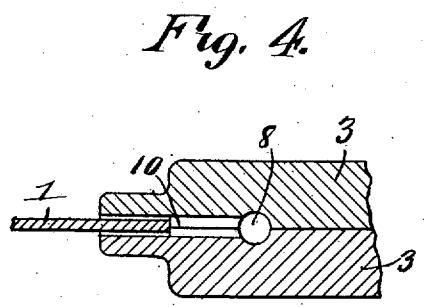
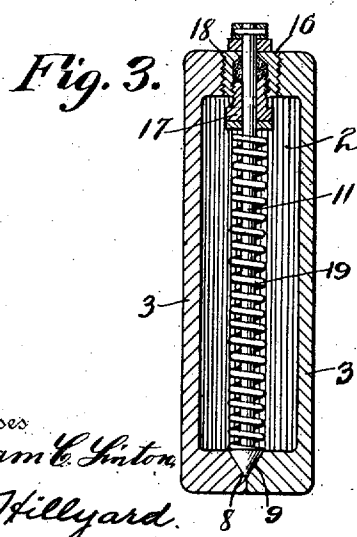
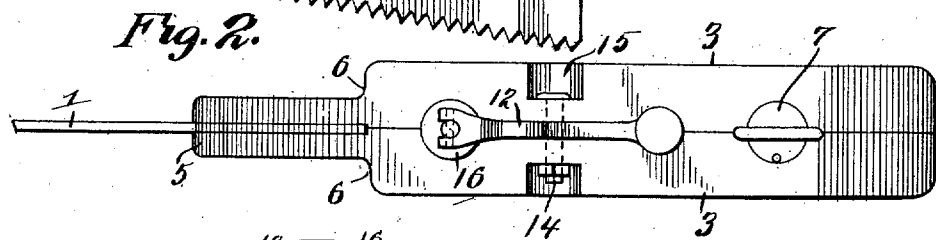
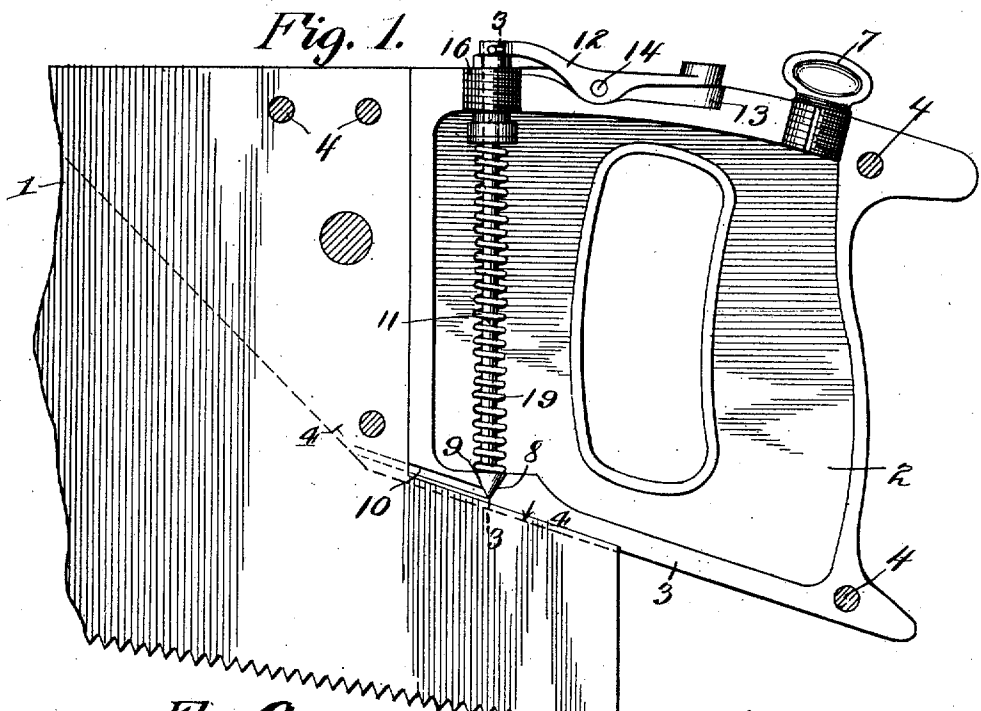

Witnesses
William C. Linton
U. B. Hillyard.

Inventor
James Franklin Mixon.

By Victor J. Evans
Attorney

UNITED STATES PATENT OFFICE.

JAMES FRANKLIN MIXON, OF MANATEE, FLORIDA, ASSIGNOR OF ONE-THIRD TO
CLAUDE EDWARD GATES, OF MANATEE, FLORIDA.

SAW-HANDLE.

986,487.

Specification of Letters Patent. Patented Mar. 14, 1911.

Application filed October 12, 1909. Serial No. 522,222.

To all whom it may concern:

Be it known that I, JAMES FRANKLIN MIXON, a citizen of the United States, residing at Manatee, in the county of Manatee and State of Florida, have invented new and useful Improvements in Saw-Handles, of which the following is a specification.

The present invention provides a handle for hand saws designed most especially for lubricating the saw blade to facilitate the operation of the saw and prevent its sticking by binding against the sides of the kerf.

The invention contemplates a chambered handle adapted to contain a quantity of lubricant and a valve mechanism for regulating the outflow of the oil as may be desired to lubricate the said blade.

The invention further contemplates a novel construction of handle which will admit of the same being readily supplied with a quantity of oil and which will admit of the oil discharging in regulated quantity as may be desired to insure easy working of the saw when in operation.

The invention consists of the novel features, details of construction and combinations of parts which hereinafter will be more particularly set forth, illustrated in the accompanying drawing and pointed out in the appended claim.

Referring to the drawing forming a part of the specification:—Figure 1 is a view in elevation of the rear portion of a saw blade and handle embodying the invention, one half of the handle being removed and showing fastening means in sections. Fig. 2 is a top plan view of the parts illustrated in Fig. 1. Fig. 3 is a section of the handle on the line 3—3 of Fig. 1. Fig. 4 is a sectional detail on the line 4—4 of Fig. 1.

Corresponding and like parts are referred to in the following description and indicated in the views of the drawing by the same reference characters.

The invention is designed most especially for hand saws such as used by carpenters and journeymen for lubricating the saw blades, thereby overcoming the practice generally in vogue by lubricating the saw blade either from oil discharging from a can or by means of a lubricant applied to the saw blade by hand.

The saw blade is indicated at 1 and may be of any size or variety.

The handle is hollow or chambered as indicated at 2, said chamber constituting a reservoir to receive a quantity of oil. The handle may be of any construction and preferably consists of similar sections or parts 3 which are placed together and secured in any manner as by fastenings 4 which are passed through openings formed transversely in the parts 3. The meeting faces of the parts or sections 3 are formed in a manner to secure a closed joint so as to prevent waste of oil.

In the preferred construction the handle is formed of metal and is cast in sections for the sake of simplicity and cheapness.

It is to be understood that the handle may be provided in any manner so long as it is chambered and supplied with the several openings and adjunctive parts.

The forward portion of the handle is reduced in thickness as indicated at 5 and its reduced part receives the upper rear portion of the saw blade 1, which is held in place by the fastenings 4 passing through openings therein. Shoulders 6 are formed at the inner end of the reduced portion 5 and said shoulders are arranged at a right angle to the back of the saw, thereby enabling the same to be used in the capacity of a square. An opening is formed in the upper rear portion of the handle leading into the chamber 2 and is closed by means of a plug 7, said opening admitting of oil being supplied to the chamber 2. A groove is provided in a side of the plug 7 to form a vent for the admission of air when oil is discharging from the handle. An opening 8 is formed in the lower front portion of the handle and constitutes an outlet for the oil, said opening being tapered and provided with a seat for a valve 9. Grooves 10 are formed in the meeting faces of the parts or sections 3 and communicate at their inner ends with the opening 8. When the valve 8 is unseated the oil passes from the chamber 2 of the handle through the opening 8 into the grooves or ducts 10, thence to the saw blade so as to lubricate the same.

A stuffing box is provided at the upper forward portion of the handle and receives the upper portion of a stem 11 provided at its lower end with a valve 9, the projecting end of the stem 11 being connected to the front end of a lever 12 which is mounted upon the back of the handle 2 and arranged

in a recess 13 formed therein. The lever 12 is connected to the back of the handle by means of a pin or bolt 14. To prevent the ends of the pin or bolt 14 projecting beyond the outer sides of the handle the same are recessed in line with the pin 14 as indicated at 15. The stuffing box consists of a sleeve 16 threaded into an opening formed in the back of the handle, and a gland 17 which is threaded into the sleeve 16 and serves to confine a packing 18. A coil spring 19 is mounted upon the stem 11 between the valve 9 and the gland 17 and exerts a downward pressure upon the valve to hold the same seated.

In practice the plug 7 is removed and a quantity of oil supplied to the chamber 2 after which the plug is replaced. When the saw is in operation the blade generally assumes an upright position and when it is required to lubricate the same the lever 12 is operated and unseats the valve 9, thereby permitting a similar quantity of oil to pass from the chamber 2 through the opening 8 and ducts 10 to the blade. Upon releasing the pressure upon the lever 12 the valve 9 is automatically seated by the action of the spring 19, thereby shutting off further discharge of the oil.

From the foregoing description, taken in connection with the accompanying drawings, the advantages of the construction and of the method of operation will be readily apparent to those skilled in the art to which

the invention appertains, and while I have described the principle of operation of the invention, together with the device which I now consider to be the best embodiment thereof, I desire to have it understood that the device shown is merely illustrative, and that such changes may be made when desired as are within the scope of the claim appended hereto.

Having thus described the invention what is claimed as new, is:—

A lubricating handle for hand saws, said handle being chambered and comprising similar parts each having a recess in one side and having its forward portion offset, the two sections when placed together having an oil chamber between them and receiving the saw blade between the offset forward extensions, the handle having an oil opening in its lower forward portion and oil ducts leading from said opening, a spring actuated valve for closing the oil opening, a lever mounted in a recess formed in the back of the handle and having connection with the stem of the valve, and a plug for closing a filling opening in the upper rear portion of the handle, said plug having a vent opening.

In testimony whereof I affix my signature in presence of two witnesses.

JAMES FRANKLIN MIXON.

Witnesses:

J. W. DOUGLAS,

J. J. STEWART.