



(86) Date de dépôt PCT/PCT Filing Date: 2009/09/23
 (87) Date publication PCT/PCT Publication Date: 2010/04/01
 (85) Entrée phase nationale/National Entry: 2011/03/22
 (86) N° demande PCT/PCT Application No.: US 2009/058018
 (87) N° publication PCT/PCT Publication No.: 2010/036699
 (30) Priorité/Priority: 2008/09/24 (US12/236,843)

(51) Cl.Int./Int.Cl. *G06K 7/10* (2006.01),
G06K 7/14 (2006.01)
 (71) Demandeur/Applicant:
GTECH CORPORATION, US
 (72) Inventeurs/Inventors:
BOZZI, STEVEN A., US;
CONSTANT, HENRY J., US;
PARKES, BRUCE I., US
 (74) Agent: SIM & MCBURNEY

(54) Titre : SYSTEME ET PROCEDE DE LECTURE SIMULTANEE DE FORMES MULTIPLES
 (54) Title: SYSTEM AND PROCESS FOR SIMULTANEOUSLY READING MULTIPLE FORMS

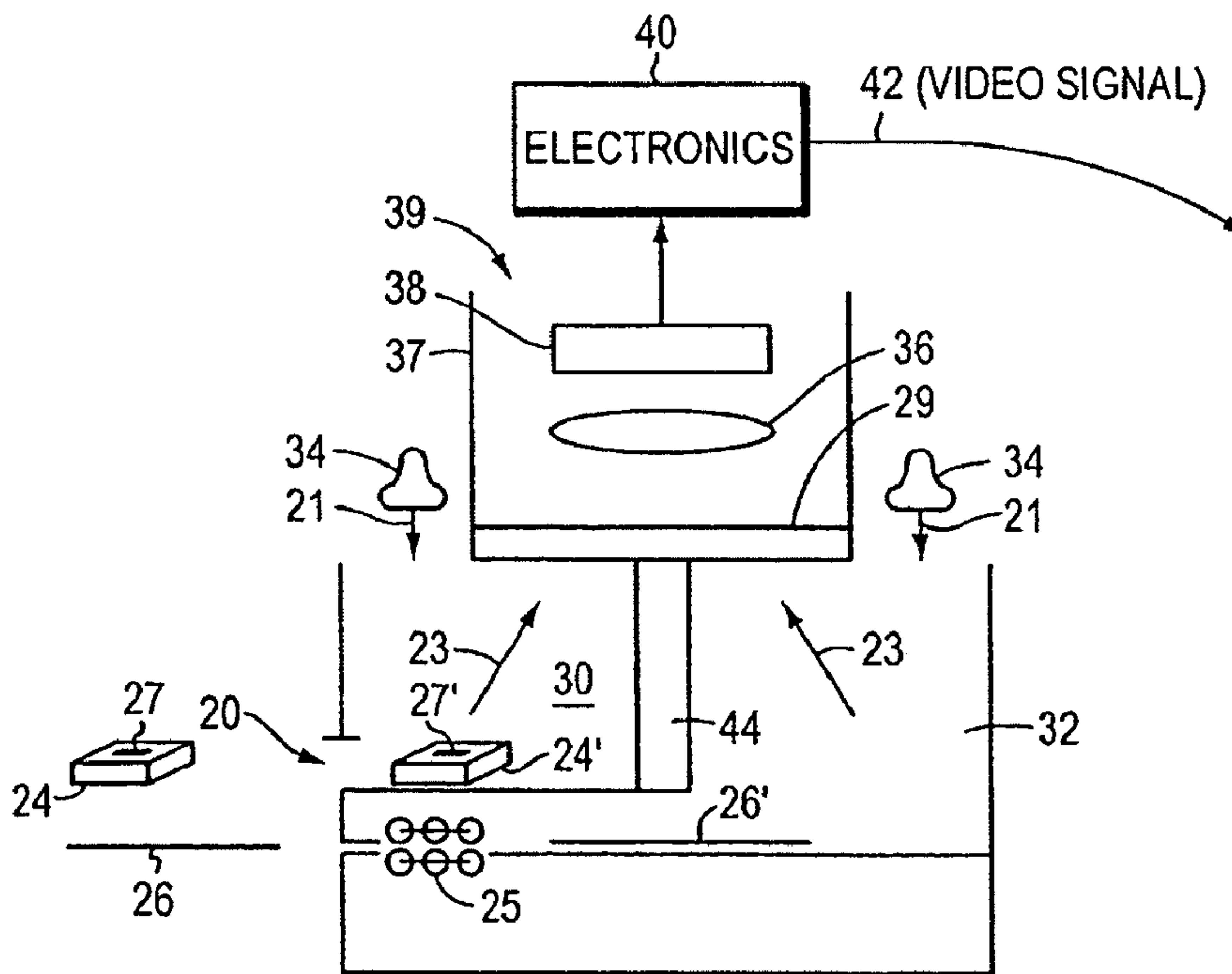

FIG. 2B

(57) Abrégé/Abstract:

An optical reader with a single optical assembly that receives images from at least two different environments. For example, one environment may be constructed in a first chamber into which a document or bulk item (24') with a bar code (27') may be placed.

(57) **Abrégé(suite)/Abstract(continued):**

The other environment may be constructed in a second chamber with an active drive mechanism (25) that transports a document (26') with optical readable markings to a reading location. The environments may be separated by a baffle (44) that prevents light from leaking between the environments, and the electronics (40) and software are constructed to read and decode information that is found in the images from both environments either sequentially or simultaneously.

(12) INTERNATIONAL APPLICATION PUBLISHED UNDER THE PATENT COOPERATION TREATY (PCT)

(19) World Intellectual Property Organization
International Bureau(43) International Publication Date
1 April 2010 (01.04.2010)(10) International Publication Number
WO 2010/036699 A1

- (51) **International Patent Classification:**
G06K 7/10 (2006.01) *G06K 7/14* (2006.01)
- (21) **International Application Number:**
PCT/US2009/058018
- (22) **International Filing Date:**
23 September 2009 (23.09.2009)
- (25) **Filing Language:** English
- (26) **Publication Language:** English
- (30) **Priority Data:**
12/236,843 24 September 2008 (24.09.2008) US
- (71) **Applicant (for all designated States except US):** **GTECH CORPORATION** [US/US]; 10 Memorial Boulevard, Providence, RI 02903 (US).
- (72) **Inventors; and**
- (75) **Inventors/Applicants (for US only):** **BOZZI, Steven, A.** [US/US]; 20 Roxbury Road, Narragansett, RI 02882 (US). **CONSTANT, Henry, J.** [US/US]; 204 Coit Avenue, West Warwick, RI 02893 (US). **PARKES, Bruce, I.** [AU/US]; 76 Hope Hill Terrace, Cranston, RI 02921 (US).
- (74) **Agent:** **MYRICK, Ronald;** Finnegan, Henderson, Farabow, Garrett & Dunner, LLP, 901 New York Avenue NW, Washington, DC 20001-4413 (US).

- (81) **Designated States (unless otherwise indicated, for every kind of national protection available):** AE, AG, AL, AM, AO, AT, AU, AZ, BA, BB, BG, BH, BR, BW, BY, BZ, CA, CH, CL, CN, CO, CR, CU, CZ, DE, DK, DM, DO, DZ, EC, EE, EG, ES, FI, GB, GD, GE, GH, GM, GT, HN, HR, HU, ID, IL, IN, IS, JP, KE, KG, KM, KN, KP, KR, KZ, LA, LC, LK, LR, LS, LT, LU, LY, MA, MD, ME, MG, MK, MN, MW, MX, MY, MZ, NA, NG, NI, NO, NZ, OM, PE, PG, PH, PL, PT, RO, RS, RU, SC, SD, SE, SG, SK, SL, SM, ST, SV, SY, TJ, TM, TN, TR, TT, TZ, UA, UG, US, UZ, VC, VN, ZA, ZM, ZW.
- (84) **Designated States (unless otherwise indicated, for every kind of regional protection available):** ARIPO (BW, GH, GM, KE, LS, MW, MZ, NA, SD, SL, SZ, TZ, UG, ZM, ZW), Eurasian (AM, AZ, BY, KG, KZ, MD, RU, TJ, TM), European (AT, BE, BG, CH, CY, CZ, DE, DK, EE, ES, FI, FR, GB, GR, HR, HU, IE, IS, IT, LT, LU, LV, MC, MK, MT, NL, NO, PL, PT, RO, SE, SI, SK, SM, TR), OAPI (BF, BJ, CF, CG, CI, CM, GA, GN, GQ, GW, ML, MR, NE, SN, TD, TG).

Published:

- with international search report (Art. 21(3))
- before the expiration of the time limit for amending the claims and to be republished in the event of receipt of amendments (Rule 48.2(h))

(54) **Title:** SYSTEM AND PROCESS FOR SIMULTANEOUSLY READING MULTIPLE FORMS

FIG. 2B

(57) **Abstract:** An optical reader with a single optical assembly that receives images from at least two different environments. For example, one environment may be constructed in a first chamber into which a document or bulk item (24') with a bar code (27') may be placed. The other environment may be constructed in a second chamber with an active drive mechanism (25) that transports a document (26) with optical readable markings to a reading location. The environments may be separated by a baffle (44) that prevents light from leaking between the environments, and the electronics (40) and software are constructed to read and decode information that is found in the images from both environments either sequentially or simultaneously.

**SYSTEM AND PROCESS
FOR SIMULTANEOUSLY READING OF MULTIPLE FORMS**

RELATED APPLICATIONS

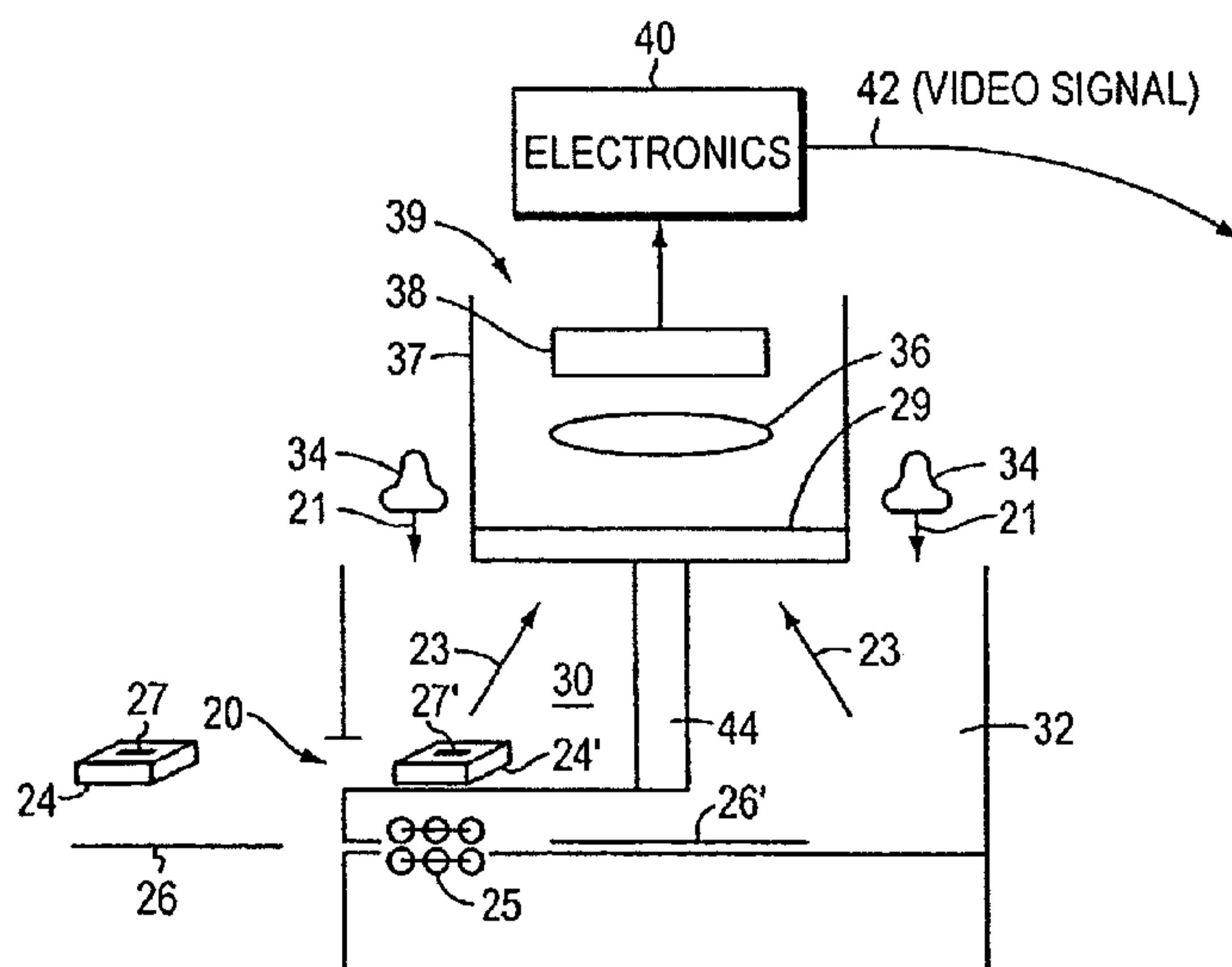
The present invention is a continuation-in-part of United States Patent Application Serial No. 11/376,052, filed March 14, 2006, entitled SYSTEM AND METHOD FOR PROCESSING A FORM, which claims priority from U.S. Provisional Patent Application
5 Serial No. 60/661,698, which was filed on March 14, 2005. Each of these patent applications is of common ownership with the present invention. These earlier applications are incorporated herein by reference.

BACKGROUND OF THE INVENTION

Field of the Invention

10 The present invention is related to a system and a process for simultaneously or sequentially reading diverse types of data on single or multiple forms or documents or bulk items like packets of tickets or retail goods.

Background Information

FIG. 1 illustrates an exemplary terminal 2 that includes a reader 4 for bar codes
15 and a slot 6 leading to an internally mounted optical reader 5 of markings on a different form. These terminals 2 are found in locations where it is important, if not essential, among other purposes, to identify, verify or authenticate the markings or data on the form and/or document that is being presented. One such exemplary venue is a retail
20 establishment where agents may sell lottery instant, online game tickets; packets of tickets; play slips; and/or other types of lottery games in addition to other commonly purchased retail or bulk items. Commonly, when an instant ticket is purchased by a player, the ticket has a bar code that is uncovered on the ticket. Operationally, the agent typically scans the bar code on the ticket by presenting the ticket to the reader 4, the bar code information is sent to a central location via the terminal where the ticket is verified

as being a winning ticket, and authorization is passed back to the agent to pay the player a winning amount. The winning amount of a particular ticket is often found on the ticket.

Herein the term "document" is defined to include but not be limited to any type of form or document, e.g., lottery ticket, game ticket or play slip, and the phrase "bulk
5 items" is defined to include but not be limited to any type of retail item, e.g., packets of tickets, t-shirts, toy, mug, or other item typically vended in a retail environment.

The internal optical reader 5 handles documents by an active drive mechanism. In the foregoing example, such active drive mechanisms are useful for reading lottery play slips. Such play slips have many forms, but usually include a set of numbers, icons, or
10 other devices that are selected by the player marking the play slip for a future drawing or event. One common type is a Keno play slip, where a group of numbers are pre-selected by the player and fed into the terminal 6. This information is sent to a central location via the terminal where it is logged and serialized. The serial number is sent back to the terminal that prints out a receipt slip with the numbers and the serial number, etc., and
15 typically a bar code of the serial number and the date and game being played.

Active drive mechanisms are defined herein as tractor or pinch drive mechanisms using rubber wheels, endless belts or tracks, or vacuum systems to transport documents to the internal optical reader 5.

Since play slips are handled by players, markings will vary, and the tickets may
20 be bent, rolled or otherwise mishandled. The terminal has a slot 6 leading to the internal optical reader 5. An active drive mechanism flattens, securely holds, registers, aligns and carries the play slip into and past a reader and returns it to the player along with a play receipt.

With respect to the Keno example above, the Keno numbers are drawn and if the
25 numbers drawn match some or all the numbers selected on the receipt, the play slip is a winner and the receipt can be presented to the agent for payment. Upon presentation, the bar code on the winning receipt is scanned by the reader 4, and sent to a central location whereupon, if the receipt is confirmed to be a winner, it is validated and authorization is returned to the agent to pay the user.

30 The active drive mechanism provides many advantages in that the document is held at a fixed, known distance from a light source and the optical imager, it is held flat

and aligned, and the drive moves the document in front of the imager at a uniform rate. Such a mechanism, thus, removes many variables with respect to reading a document and enhances reliability in the reading of the document.

One limitation of such terminals is that two separate optical readers are required
5 to accomplish the above-discussed objectives. Another limitation is that the cost of each reader is a significant portion of the cost incurred in the manufacture of the terminal and, in fact, often times results in a 40-50% increase in the overall cost of the terminal. Another limitation is that the use of two readers in the validation process may decrease the reliability (neither can be 100% reliable) of the information being read. Still another
10 limitation is that terminals utilizing two separate optical readers are typically larger devices, which require a larger "footprint" and thereby take up a larger portion of the counter space available on a retailer's checkout counter.

It would be advantageous to provide a single optical reader that is capable of simultaneously or sequentially reading different types of documents or forms, is capable
15 of simultaneously or sequentially reading different types information on the same document or form, and is also capable of performing those reading functions simultaneously with or sequentially to reading bulk items.

SUMMARY OF THE INVENTION

The present invention addresses the limitations of the prior art by providing a
20 single optical reader assembly with one or more a photo-sensitive surfaces (imagers) that is arranged to receive images from at least two fields of view, and where the environment associated with each field of view may be different, e.g., different lighting, differently sized chambers to accommodate different sizes of documents and bulk items. Either or both fields of view, in turn, may be divided into one or more sub-fields of view. For
25 example, an instant ticket or a bulk item may be in one field of view and a play slip in the other. These two documents may be read simultaneously or sequentially.

Illustratively, a single optical reader is employed where its field of view is partitioned into two or more fields of view separated by an optical barrier or baffle. A first field of view is designed to read a first code on a first document type, e.g., a bar
30 code, and the second field of view reads a second form type, e.g., a play slip filled in by

the player, where the play slip is handled by an active drive mechanism. In one example each field of view is imaged on separate photo-sensitive surfaces. In this example, both photo-sensitive surfaces are scanned by electronics to produce a single video signal. The two optical surfaces may provide different resolutions and they may provide depth perception to bulk items.

In one embodiment, the field of view of the optical includes a square matrix of pixels with a 1280 by 1024 resolution. A portion of the pixels are dedicated to reading a first code and another portion to read the second type in the active drive mechanism. Illustratively, if the first code is a bar code, the reader searches for video lines from a first field of view that correspond to the optical response associated with standard bar code print patterns; and, if the second code are the markings on a play slip, the reader interprets the second field of view looking for marks filled in by the player.

Illustratively, the bar code may use any standard symbols, e.g., 1-D or 2-D bar code; the camera may be a CCD or CMOS, diode or transistor arrays, and the light source may be a LED array of a frequency (e.g., 630 nm) or spectrum that matches the camera sensitivity and the printed surfaces being read. Other optical imagers and other light sources may be used in the present invention. The selection an optical imager, light source and encoding/decoding of bar codes are well-known in the industry and, so, are only incidentally mentioned below.

It will be appreciated by those skilled in the art that although the following Detailed Description will proceed with reference being made to illustrative embodiments, the drawings, and methods of use, the present invention is not intended to be limited to these embodiments and methods of use. Rather, the present invention is of broad scope and is intended to be defined as only set forth in the accompanying claims.

BRIEF DESCRIPTION OF THE DRAWINGS

The invention description below refers to the accompanying drawings, of which:
FIG. 1 is a view of a prior art terminal with optical readers;
FIG. 2A is a view of an optical reader constructed in accordance with the present invention;

FIG. 2B is a schematic block diagram of an optical/electronics system suitable for use in the present invention;

FIG. 2C is another view of an optical reader constructed in accordance with the present invention;

5 FIG. 3 is a block diagram of a hardware/software system suitable for use in the present invention;

FIG. 4 is an illustration of a single camera field of pixels, 1280 by 1024, that is split into two fields, each field with a different image impressed thereon.

DETAILED DESCRIPTION OF AN ILLUSTRATIVE EXAMPLE

10 The following discussion illustrates an example of the present application where markings on one type of form or document are read simultaneously or sequentially with markings on another type of form or document. For example, a bar code on an instant ticket may be read simultaneously with the markings on a play slip. Other documents however, may be advantageously processed by the present invention. Moreover, while
15 the discussion below illustrates use of an active drive mechanism for documents, in other applications two or more documents and bulk items may be processed without an active drive mechanism, and conversely two active drive mechanisms may be found in other applications.

FIG. 2A illustrates a terminal 3 with an opening 20 to a chamber where a
20 document or a bulk item, such as a bar coded ticket or a pack of tickets, respectively, may be inserted and read, and an entrance 22 to another chamber where another document, such as a play slip, can be inserted and read. These readings may be sequential or simultaneous.

FIG. 2B shows, within the terminal 3, a light source assembly 34 arranged around
25 the sides of an optical imager filter 29, lens 36 and photo-sensitive surface 38. Here “optical imager” refers to the assembly 39 of the photo-sensitive surface 38, and the lens 36 and filter 29 (if present). The lens 36 and the filter 29 may not be present in some applications. Light rays 21 are prevented from shining directly into the filter 29 by the opaque sides 37. The light rays 21 emanate from the assembly 28 and rays 23 are

reflected, e. g., from the ticket packet 24' and the playslip 26' and return to the optical imager 39.

5 A bulk item, in this case a packet of tickets 24' bearing a bar code 27 is inserted through the opening 20 into the chamber 30. The packet bar code 27' is illuminated by the light rays 21. A playslip 26 may be inserted into the opening 22 where the active drive mechanism 25 carries the play slip 26 into (and, later, out of) the chamber 32. The play slip 26' is also illuminated by the light rays 21. In both instances, reflected rays 23 from the ticket packet bar code 27' and the play slip 26' are returned to the optical imager 39.

10 The optical imager's photo-sensitive surface 38 is scanned by electronics 40 that output a video signal 42 as a data stream of pixels that carry an image. The software may interpret the entire photo-sensitive surface as one image even though there may be two or more different documents and/or bulk items with readable coded information.

15 Alternatively, the software may separately interpret images from each document or bulk item. Each pixel is represented by an electrical signal (or group of signals) that represent optical values of intensity (gray levels and/or colors) at specific locations on each target. The image is an optical representation of the targets and the pixels run, generally, from left to right and top to bottom presenting the illuminated image of the targets 24' and 26'.

20 The light source assembly 34 in FIG. 2B illuminates both targets 24' and 26', and reflected light 23 from the targets returns to the optical filter 29. A single light source may be arranged to illuminate both targets, or an array of light sources may be arranged to illuminate both targets, or separate light sources, with different optical characteristics, may be each arranged to illuminate one target. Other surfaces within the cavities 30 and 32 are oriented and blackened to eliminate spurious reflections that might be returned to the optical filter. A baffle 44 is a physical barrier separating the chambers 30 and 32 from each other. In this manner, the target 24' will be imaged on about half of the photo-sensitive surface 38 while the light from target 26' will only strike the other portion of the photo-sensitive surface 38. In other embodiments, depending on the disposition of the baffle or baffles employed, different areas of the photo-sensitive surface will have images of other targets (not shown).

25

30

Illustratively, the filter 29 and the lens 36 both condition the light signals. The filter 29 may remove any background color associated with the targets, and the lens 36 focuses the light onto the photo-sensitive surface 38.

5 The photo-sensitive surface 38 may be one of many electronic optical arrays that are light sensitive, e.g., CCD, diode arrays, CMOS array, or any similar devices. (Even TV camera tubes may be used.) These optical arrays are usually scanned in an X/Y pattern that directly maps an area of the targets. As known to those skilled in the art, there will be a scaling factor and the scanned target area may not represent the entire target.

10 FIG. 2C illustrates the optical reader assembly 39 mounted vertically above two chambers 30 and 32 within a terminal 3. Two forms 24 and 26 lie below the optical reader 39 when inserted into the chambers 30 and 32, respectively.

15 Although two chambers, 30 and 32 separated by the baffle 44 are shown in FIG. 2C, other applications may include additional chambers having openings for receiving documents of bulk items. These additional chambers may comprise environments and may be separated by additional baffles that incorporate additional light sources. Additional active drive mechanisms may also be employed.

20 In yet other applications, the chambered assembly with an optical reader may be arranged in a stand alone configuration separate from other terminal functions (like communicating with a central office, etc.).

25 FIG. 3 shows an image timing and control signal 45 to the camera electronics 40 and a video data stream 42 of pixels to the electronic assembly 41. The electronics assembly 41 has a processor system 46 that, preferably, includes a DSP (digital signal processor) or a FPGA (field programmable gate array), but a micro-processor may be used in some applications. The processing system 46 includes I/O device drivers and buffers for, at least buttons, display and communications. Memory 48 includes, at least, one or more image buffers and operating applications. In one embodiment and external, removable Flash memory 49 is used to up load the application program to the processor system 46. Removing the Flash memory 49 from the terminal 3 removes all the software
30 from the terminal.

The network may be the Internet or a private network, but in either case the information must be encrypted to prevent outside interference such as, for example, in the illustration discussion of instant lottery tickets, with the gaming transactions, etc.

According to this example, the bar code on a winning game ticket may be sent to a
5 central controller 52 where the ticket is verified. Once verified, the central controller 52 will return authorization for the agent to pay the ticket.

FIG. 4 represents a stylized version of the pixels entering the electronic assembly 41 with the targets 24' and 26' mapped thereon. In one embodiment, the pixels are distributed in a square pattern of 1280 by 1024 array of horizontal and vertical lines.
10 Here half (512) of the lines are used for the bar code image 60 and half (512) for the play slip image 62. The pixel array may be proportioned differently and used to advantage reading different ticket and play slip types. The pattern of the bar code and the printed portions of the play slip are used by known programs to identify and read the information of the bar code and on the play slip.

15 The baffle 44 may cast a shadow on the photo-sensitive surface (here, a pixel array) that may remove several horizontal lines of pixels from participating in the images of the items in the chambers 30 and 32.

The reading of the bar code may include reading adjacent horizontal video lines and correlating the video patterns to define and then decode a bar code.

20 As mentioned above, the surface imaging the bar code and the surface imaging the bet slip may be two different surfaces that are electronically read out as one surface producing a single video signal. However, the bar code imager for the bar code may also be divided into two surfaces that adds a depth perception to the field of view. If the entire bar code is imaged on each of the two surfaces, a bulk item with a non-flat bar
25 code may be read better with a depth of view provided by the binocular view.

It should be understood that above-described embodiments are being presented herein as examples and that many variations and alternatives thereof are possible. Accordingly, the present invention should be viewed broadly as being defined only as set forth in the hereinafter appended claims.

30

What is claimed is:

CLAIMS

- 1 1. An optical reader for processing images from at least two different environments,
2 the optical reader comprising:
3 a first environment for receiving a first document or bulk item;
4 at least a second environment for receiving a second document or bulk item
5 a light source assembly for illuminating the first and the at least second
6 environments;
7 an optical reader assembly having at least one photo-sensitive surface (imager),
8 constructed to receive an image from the reflected light from each environment, the
9 image from the first environment on a first portion of the photo-sensitive light surface,
10 and the image from the at least second environment on a second portion of the photo-
11 sensitive surface; and
12 electronics for scanning the photo-sensitive surface and software for decoding
13 information from each image.
- 1 2. The optical reader of claim 1 further comprising:
2 an optical filter that receives and optically filters the reflected light, and
3 a lens to focus the reflected light onto the photo-sensitive surface.
- 1 3. The optical reader of claim 1 further comprising:
2 a baffle disposed between the two environments, wherein the baffle extends up to
3 near the photo-sensitive surface and essentially restricts the reflected light within each
4 environment.
- 1 4. The optical reader of claim 1 wherein each environment defines a field of view.
- 1 5. The optical reader of claim 1 wherein the information in the images comprises a
2 bar code and markings on a play slip.

1 6. The optical reader of claim 1 wherein the first document or bulk item is a packet
2 of tickets and the second document or bulk item is a play slip.

1 7. The optical reader of claim 1 further comprising an active drive mechanism that
2 physically transports the first document to the first environment.

1 8. The optical reader of claims 1 wherein the light source assembly includes a
2 separate light source for each environment.

1 9. The optical reader of claim 1 wherein the first document or bulk item is an instant
2 ticket and the second document or bulk item is a packet of play tickets.

1 10. A process for reading images from at least two environments, the process
2 comprising the steps of:
3 illuminating a first environment;
4 illuminating a second environment;
5 simultaneously reflecting light from both environments onto an optical imager
6 having at least one photo-sensitive surface; and
7 scanning the optical imager and determining the information in the images in the
8 reflected light from both environments..

1 11. The process of claim 10 further comprising the steps of:
2 focusing the reflected light onto the photo-sensitive surface, and
3 filtering the reflective light before it impacts the photo-sensitive surface.

1 12. The process of claim 10 further comprising the steps of:
2 baffling the light reflected from the first environment from the reflected light from
3 the second environment, wherein the reflected light from the first environment
4 illuminates only a first portion of the photo-sensitive surface and the reflected light from
5 the second environment illuminates only a second portion of the photo-sensitive surface.

1 13. The process of claim 10 wherein the information of the first image comprises a
2 bar code on an instant ticket and the information on the second image comprises
3 markings on a play slip.

1 14. The process of claim 10 further comprising the step of transporting the first
2 document to the first environment.

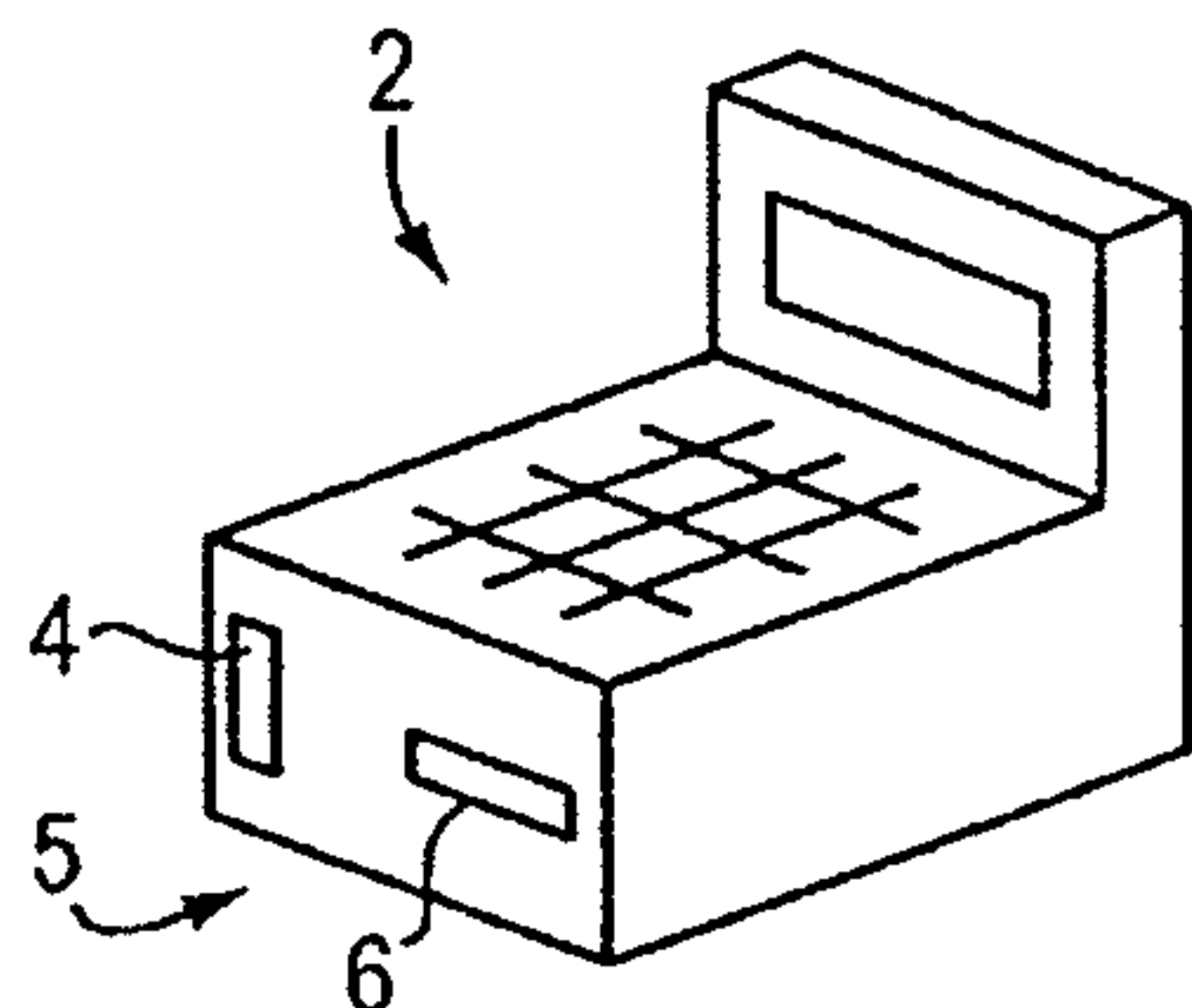

FIG. 1 (PRIOR ART)

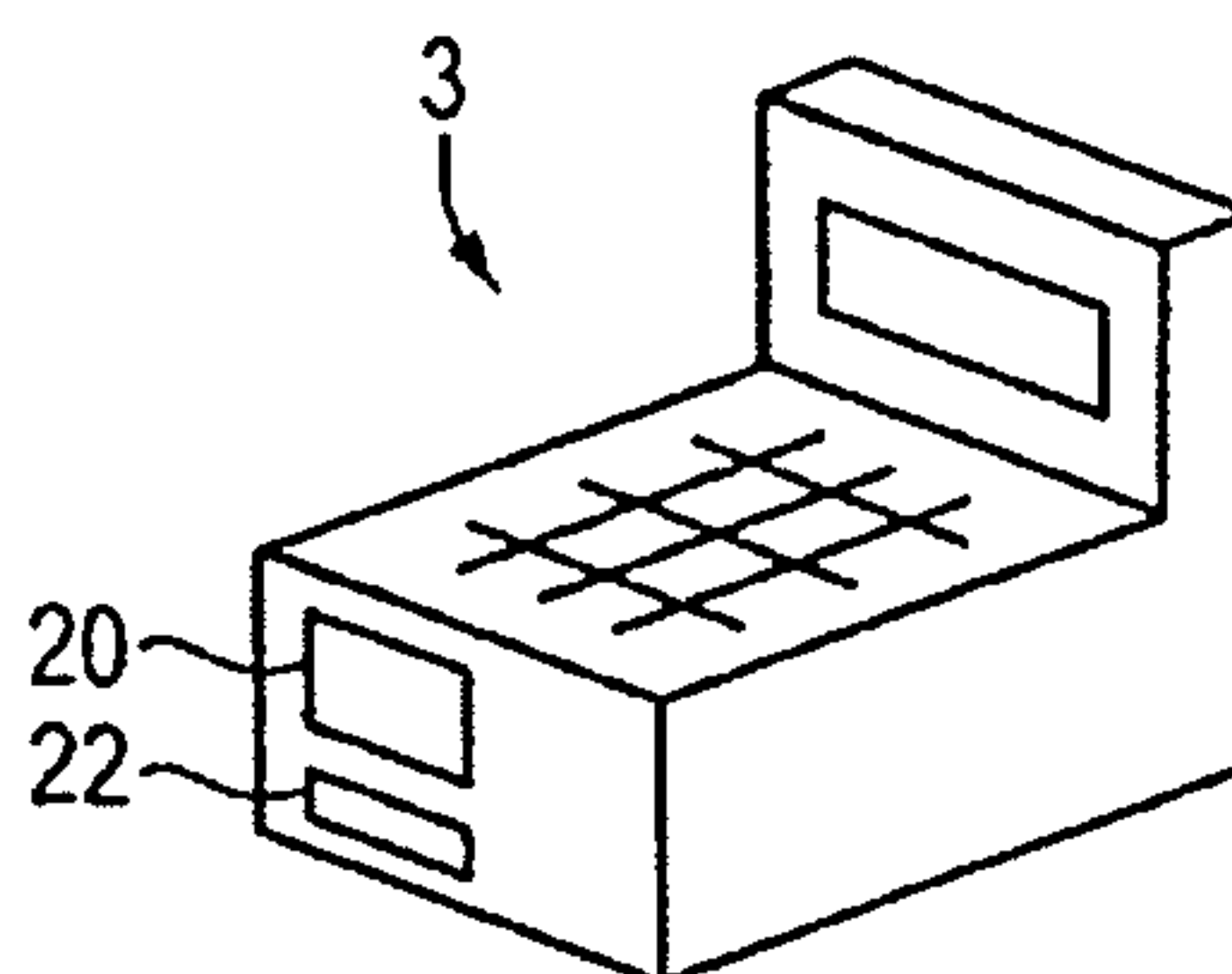

FIG. 2A

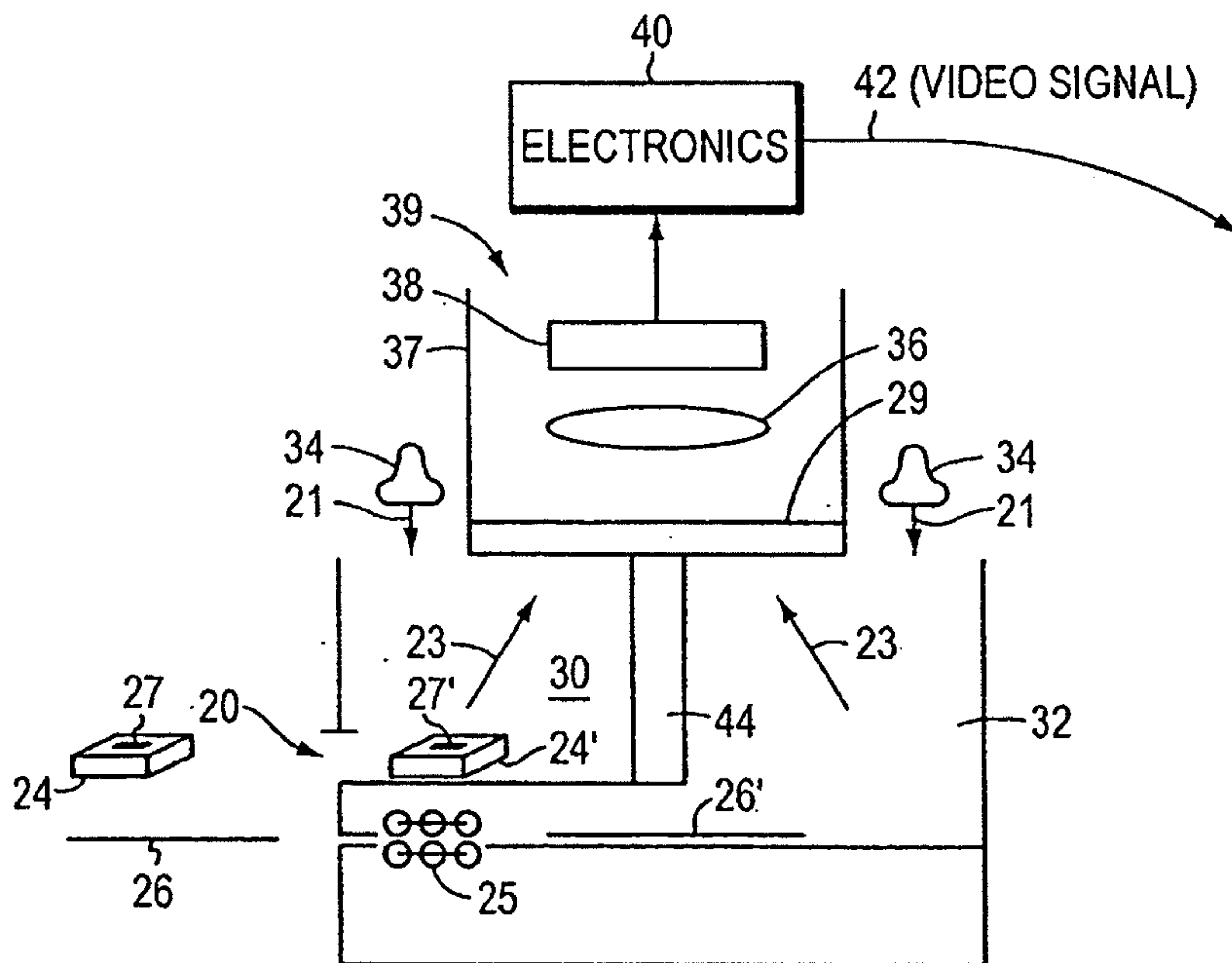

FIG. 2B

2/3

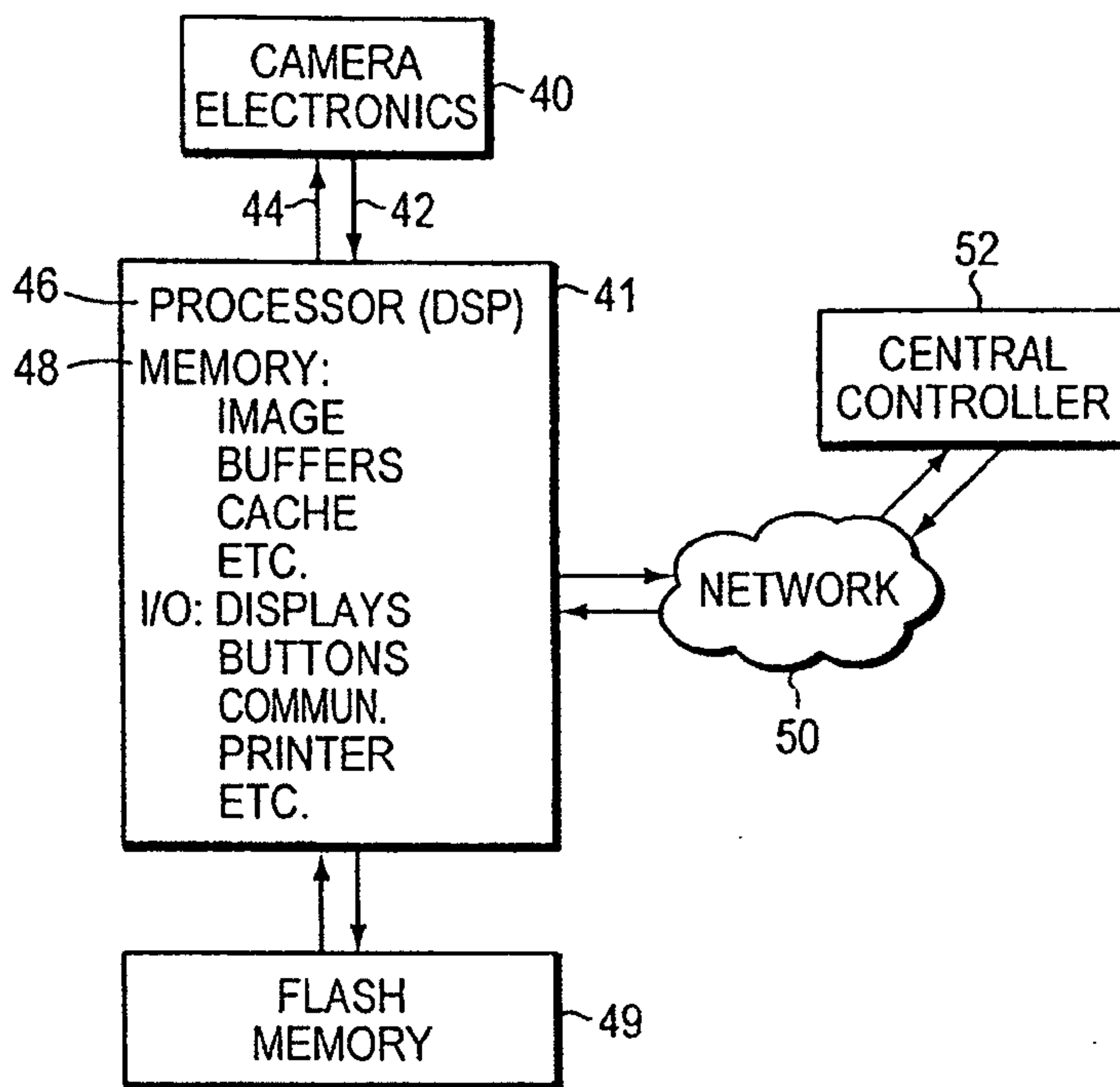

FIG. 3

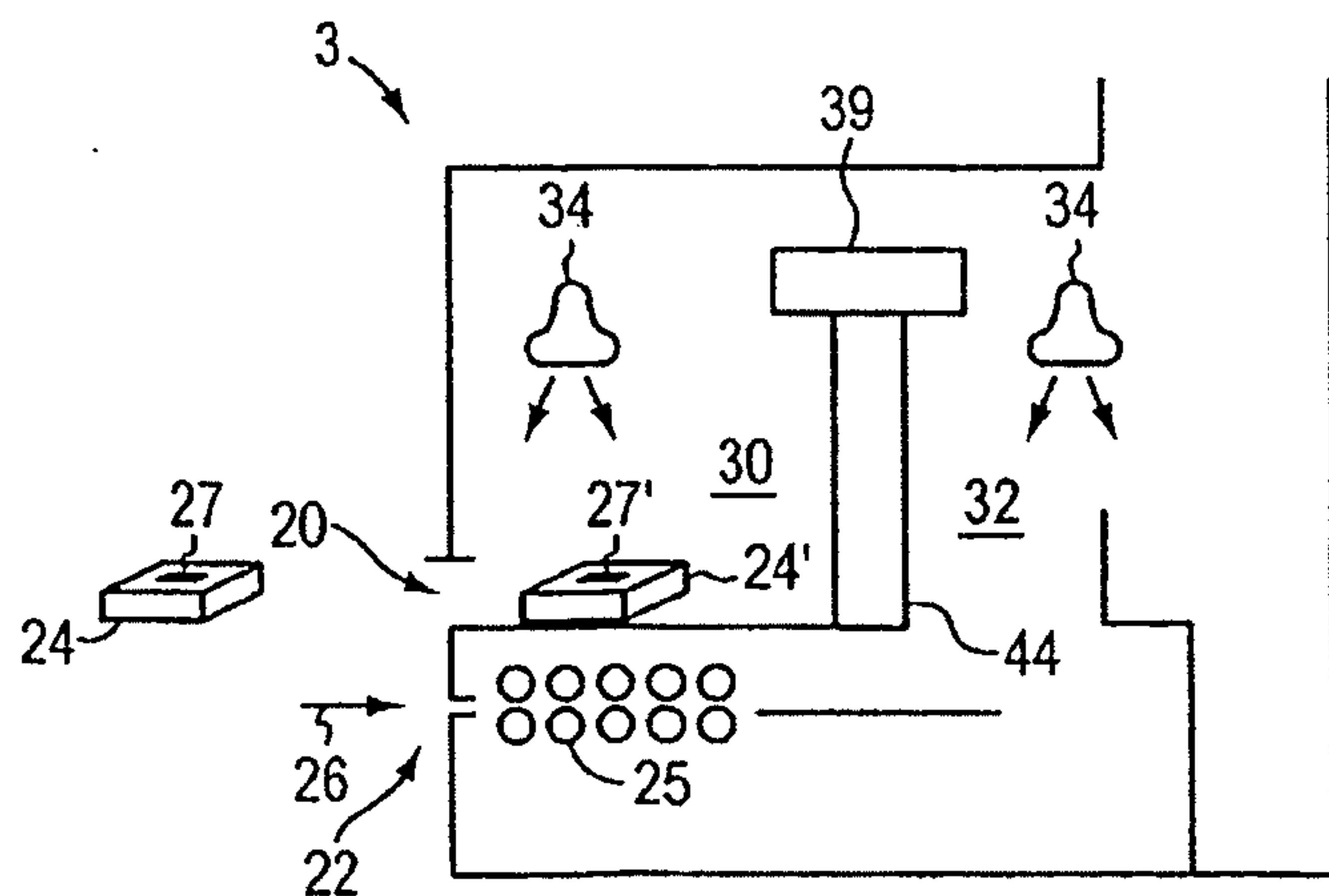

FIG. 2C

3/3

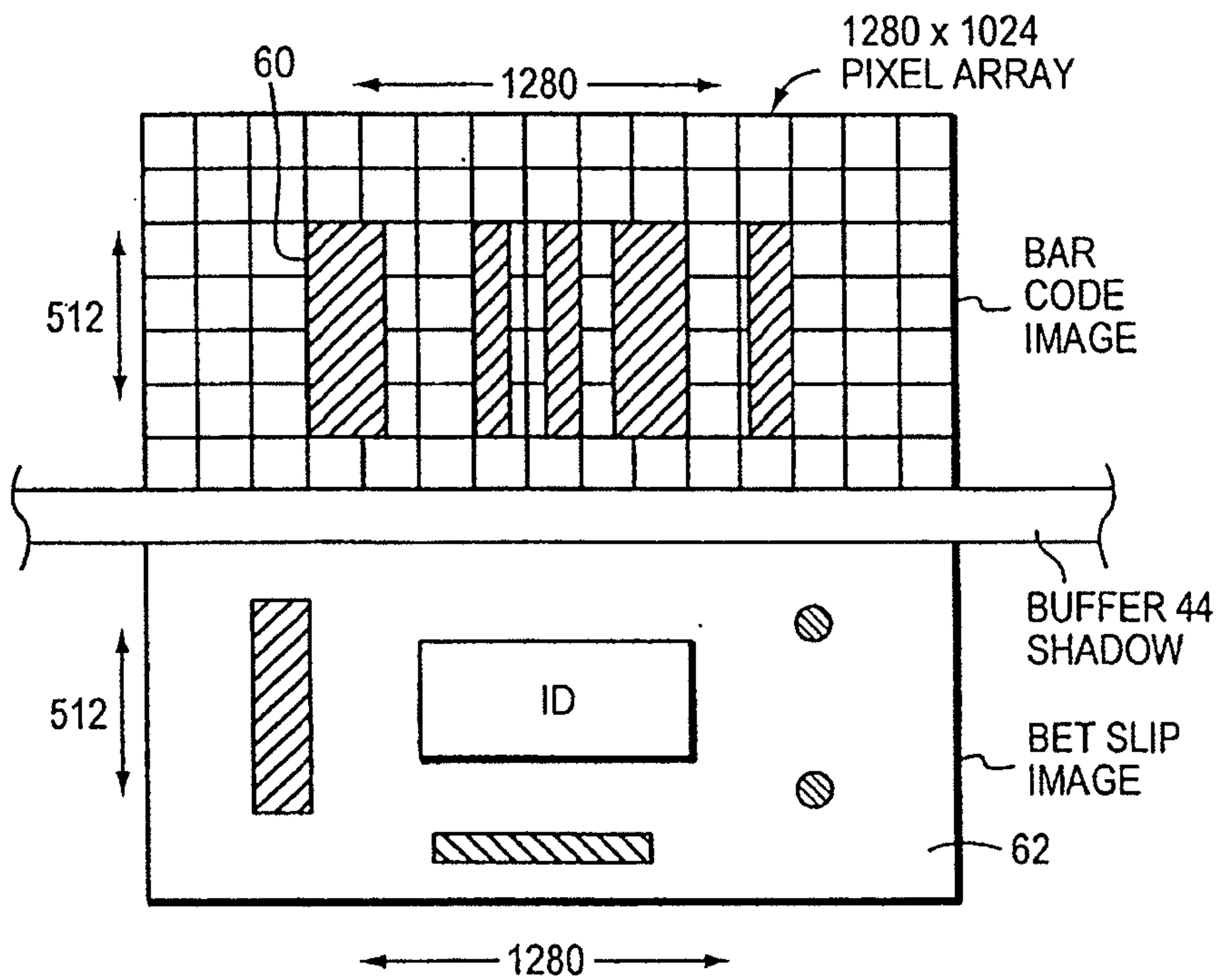

FIG. 4

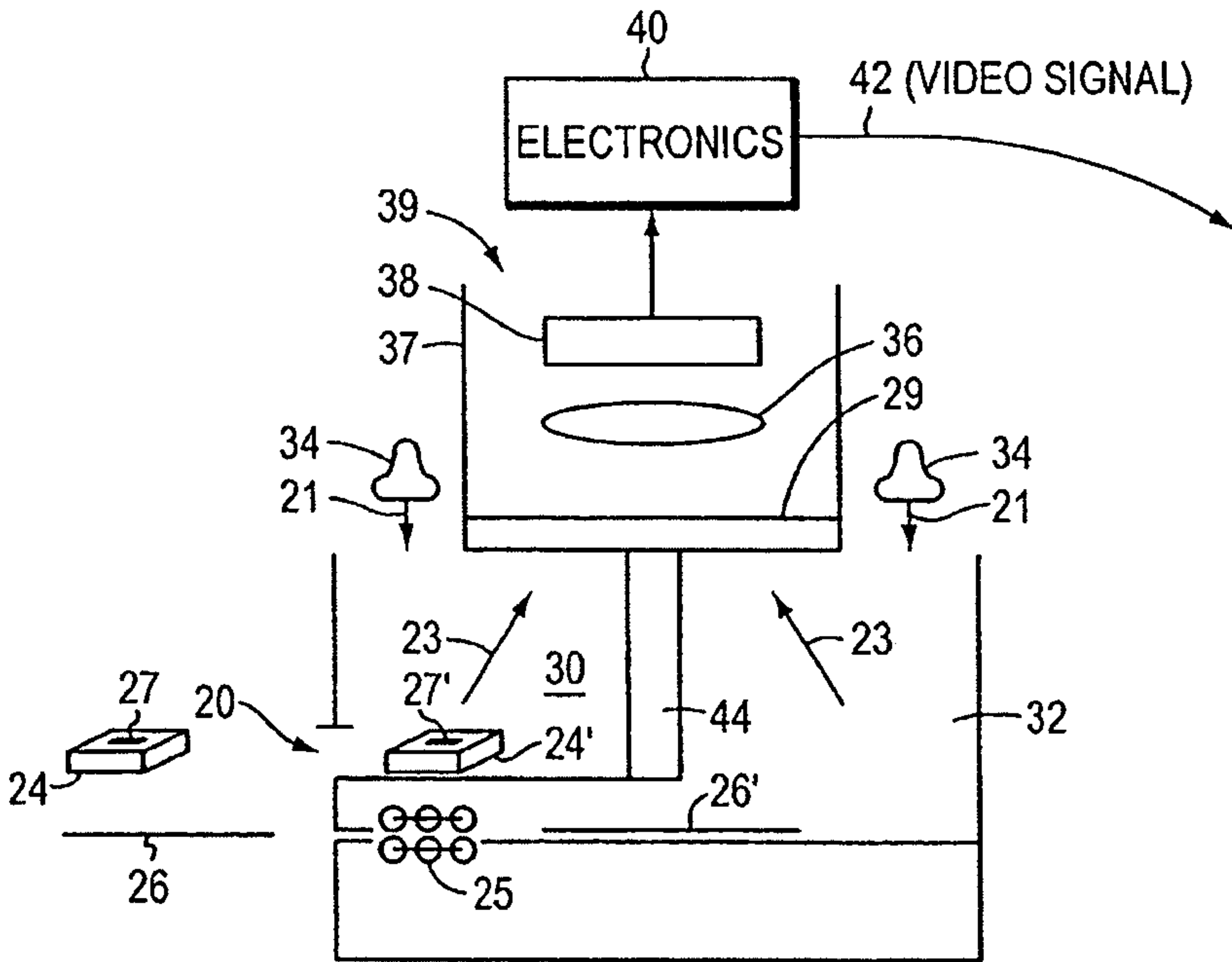

FIG. 2B