



EUROPEAN PATENT APPLICATION

Application number : **93200003.7**

Int. Cl.⁵ : **H04N 7/00, H04N 7/087, G09G 1/16**

Date of filing : **04.01.93**

Priority : **09.01.92 GB 9200426**

Inventor : Kinghorn, John Ritchie, c/o Philips Semiconductors
Millbrook Industrial Estate
Southampton, Hants SO9 7BH (GB)
Inventor : Stevens, Jeremy Robin, c/o Philips Semiconductors
Millbrook Industrial Estate
Southampton, Hants SO9 7BH (GB)
Inventor : Tarrant, David Robert, c/o Philips Semiconductors
Millbrook Industrial Estate
Southampton, Hants SO9 7BH (GB)

Date of publication of application : **14.07.93 Bulletin 93/28**

Designated Contracting States : **DE FR GB IT**

Applicant : PHILIPS ELECTRONICS UK LIMITED
Philips House 1-19 Torrington Place
London WC1E 7HD (GB)

Representative : Andrews, Arthur Stanley et al
PHILIPS ELECTRONICS Patents and Trade Marks Department Philips House 1-19
Torrington Place
London WC1E 7HD (GB)

GB

Applicant : N.V. Philips' Gloeilampenfabrieken
Groenewoudseweg 1
NL-5621 BA Eindhoven (NL)

DE FR IT

Television receiver.

The television receiver includes a teletext decoder having a page memory PM into which teletext data is read from a data acquisition circuit DAC via an interface circuit MIC under control of a microprocessor PRO. The microprocessor PRO is also used to control functions of the television receiver and to cause on-screen display messages to be produced. When an on-screen display message is to be produced the microprocessor sets a bit in the memory PM which causes a latch to be set which in turn causes a multiplexer MUX to apply data from an auxiliary memory APM to a character generator CG. When the on-screen display message is to be dispensed with the bit in the memory PM is reset causing the latch to be reset and the multiplexer MUX to apply data from the page memory PM to the character generator CG.

This enables on-screen display messages to be applied to the character generator CG without losing any of the teletext data stored in the page memory PM.

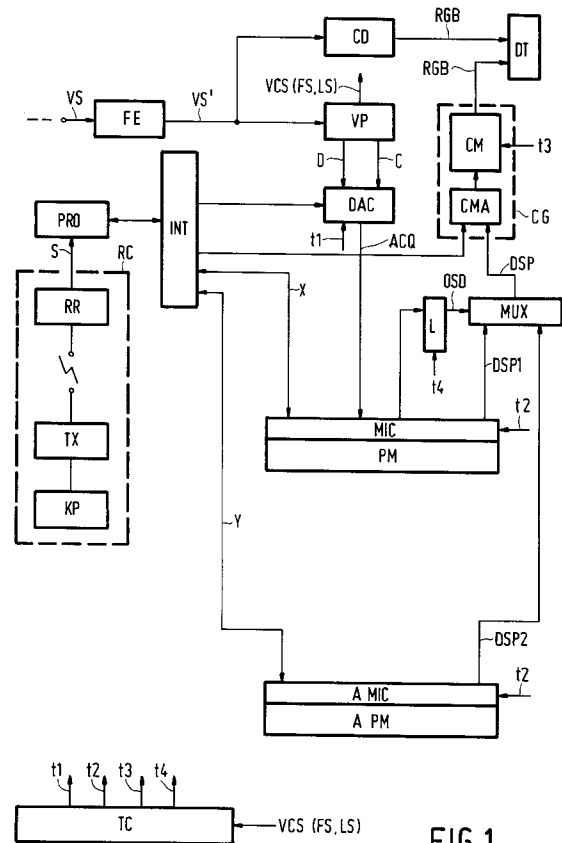

FIG.1

The invention relates to a television receiver including a teletext processor including character generator means and teletext page memory means for receiving, decoding and displaying teletext data, means for generating an on-screen message display, the on-screen message display generating means including a further memory means storing the required data for the on-screen message display, and microprocessor means for controlling the teletext processor and the on-screen message display generating means.

Such a television receiver is disclosed in US Patent No. 4633297. In the receiver disclosed in this document the on-screen display messages are stored in a read-only memory (ROM) which is read out under control of a microprocessor into the television page memory. Appropriate memory timing and control arrangements select whether the teletext data being received or the stored pages from the on-screen display ROM are written into selected locations of the teletext page memory. Data from the teletext page memory is then fed to a character generator which provides the signal for driving the display device. This arrangement enables on-screen display messages to be overlaid on the teletext data merely by writing on-screen display message data from the ROM into the teletext page memory at the appropriate locations. A disadvantage of the receiver disclosed in US Patent No. 4633297 is that when the on-screen display message is deleted, it will take an indeterminate time for the teletext data to be read into the locations of the memory which had held the on-screen display data, the time depending on the position within the transmitting cycle of the teletext information when the on-screen display message is deleted.

It is an object of the invention to enable the insertion and deletion of on-screen display messages over a teletext displayed page without an indeterminate delay in restoring the teletext information when the on-screen display information is deleted.

The invention provides a television receiver as set forth in the opening paragraph, characterised by selection means for selectively reading data from the display memory and the further memory to the character generator.

By selectively feeding data from the display memory and the further memory to the character generator the display of both teletext data and on-screen message display data can be combined on the display screen such that the on-screen message display data overwrites the teletext page data. However since a full display page of teletext data is retained in the display memory, the full teletext display data is immediately available as soon as the on-screen display data is deleted. Consequently, it is not necessary to wait for position in the cycle of teletext pages where the relevant page information is transmitted to arrive before restoring the teletext display and the on-screen message display can be instantly inserted and

deleted without affecting the availability of the teletext data for display.

The selection means may be controlled by data read from given locations of the teletext page memory. This allows a simple latch circuit to control the operation of a multiplexer which selects the output from either the display memory or the further memory.

The foregoing and other features and advantages provided by the invention will become apparent from the embodiments of the invention which will now be described, by way of example, with reference to the accompanying drawings, in which:-

Figure 1 shows in block schematic form a television receiver according to the invention,

Figure 2 shows locations in the page memory where the data selection bits are stored and,

Figure 3 shows a modification of the television receiver shown in Figure 1,

Figure 4 shows a teletext display page with an on-screen display message superimposed thereon.

The teletext television receiver shown in Figure 1 comprises video and data processing circuits for receiving and displaying both normal picture information and teletext information. The front end FE of the receiver comprises conventional amplifying, tuning, intermediate frequency and detector circuits and is connected to receive an incoming video signal VS. For normal picture display by the television receiver the demodulated video signal VS' is applied to a colour decoder which produces the RGB component signals for the picture display. Time base circuits for a display device DT, for example a cathode ray tube, receive the usual line and field synchronising pulses from a separator circuit which extracts the synchronising pulses from the video signal VS'. The element CD represents the colour decoder and these other circuits which are provided for normal picture display.

The demodulated video signal VS' is also applied to a teletext decoding section of the television receiver. This section deals with the reception and display of alpha numeric text and other teletext information which is received as digitally coded data. It comprises a video processor circuit VP, a data acquisition circuit DAC, a character generator CG, and a page memory PM. The video processor circuit VP performs inter alia data slicing for retrieving teletext data pulses D from the video signal VS' together with input data clock pulses C which are derived from the data pulses D. The data pulses D and clock pulses C are fed to the data acquisition circuit DAC which is operable to feed selected groups of the teletext data pulses over an acquisition connection ACQ to a page memory interface circuit MIC as digital codes representing address, display, and control information. The page memory PM, which has a capacity for storing the display and control information for at least one teletext display page, stores the acquired display and control information as digital codes at respective memory locations as de-

terminated by the accompanying address information.

A logic processor PRO controls the operation of the teletext decoder section via a processor interface circuit INT. As part of this control the processor PRO is operable in accordance with a page select signal S applied to it from a receiver circuit RR, which forms part of a remote control arrangement RC, to determine which teletext information is acquired by the data acquisition circuit DAC. The remote control arrangement RC further comprises a key pad KP and a transmitter TX forming the usual remote control unit supplied with many television receivers. The processor PRO is operable to access the page memory PM over a connection X, to read out from the page memory PM the stored digital codes for application via a connection DSP1 and DSP to the character generator CG. The character generator CG is responsive to the applied digital codes to produce RGB component signals for displaying the selected page. The character generator CG comprises character memory CM and an associated addressing circuit CMA. Character information representing the character shapes available for display is stored in the character memory CM which is selectively addressed by addressing circuits CMA in accordance with the digital code applied to the character generator CG from the page memory PM. The character information for each character shape is stored in at least one individual character memory location which is addressable by a respective one of the digital codes. Only a portion of the character information for a character shape is read out at any one time which portion is displayed in a current scanning line of the display. A timing circuit TC provides timing signals on connections T1 to T3 for the circuit elements DAC CG and MIC. The operation of the timing circuit TC is synchronised with the received video signal VS by a composite signal VCS which contains the line and field synchronising pulses as separated from the demodulated video signal VS' in the video processor VP.

In the teletext television receiver shown in Figure 1 only single line connections have been shown for the interconnections between the various circuit elements for the sake of simplicity. It will, however, be apparent to a person skilled in the art that in practice many of these interconnections would be multiline. For example whereas the teletext data pulses D retrieved from the video signal VS' are applied serially to the data acquisition circuit DAC over a single line connection, serial to parallel conversion takes place within the data acquisition circuit DAC so that the connection ACQ is a multiline connection for supplying the groups of teletext data pulses to the page memory PM.

Although a composite television receiver for receiving both normal picture information and teletext information is exemplified in Figure 1, it will be appreciated that the teletext decoder section for teletext in-

formation acquisition together with the front end FE may be provided as a separate teletext decoder which is adapted to feed a display monitor or a conventional television receiver. Alternatively the teletext decoder could be embedded within a video cassette recorder whose output feeds a conventional television receiver.

The teletext receiver as described so far is the same as that described in U.K. Patent Application No. 2223650 (PHB 33497) and for the present purposes it will be assumed that the teletext information to be processed by a teletext decoder embodying the present invention conforms to the specification laid down in the document World System Teletext and Data Broadcasting System, December 1987 published by The U.K. Department of Trade and Industry. In this document a quantity of teletext information to be considered as an entity is termed a page. All the pages which are available are normally transmitted in a recurrent cycle with or without updating page information as appropriate. The pages are numbered and the teletext decoder is operable to select any page by number and the digital codes representing the page information are acquired by the teletext decoder from the cyclic transmission and stored in the page memory for as long as the page is required. The page information comprises digital codes representing display and control information and addresses for up to 24 display rows each having 40 character positions. The first display row, (row 0) of each page is termed a page header and contains inter alia the page number. The page information for a page can also include one or more extension data packets which are received and stored in page memory along with the basic display information for the page concerned. Such an extension data packet can for example be used to change the character which is to be displayed at a particular character position and in particular may include data from which row attributes which define the background colour for each row to be displayed can be derived.

The page memory PM1 holds data contained in row 25 of the teletext page. Row 25 is not displayed on the display device but contains a number of control characters. The last 14 columns of row 25 contain the row attributes. These comprise a 3 bit number for each teletext row and the areas at the top and bottom of the screen outside the normal text display area to define the default background colour for the row.

The processor PRO is also arranged to control the receiver and includes in this function the creation of on-screen display messages to indicate to the user the function being controlled. Conventionally the data required to display these on-screen display messages is supplied to the page memory PM over the connection X and is arranged to overwrite the acquired teletext data which was previously present in the page memory PM. This overwriting may be on a row

by row basis so that only that portion of the teletext display page which is occupied by the on-screen display message is overwritten. As has been stated hereinbefore this procedure suffers from the disadvantage that when the on-screen display message is dispensed with the teletext data which has been overwritten is no longer available and hence display of the full teletext page is not possible until that page is again acquired from the cyclic transmission of teletext data.

The receiver shown in Figure 1 further comprises a second auxiliary page memory APM which holds the on-screen display information and has associated with it a memory interface circuit AMIC. The processor PRO accesses the memory APM over the connection Y through the interface circuit AMIC to enable the required on-screen display data to be selected and read out at the appropriate times. The memory APM may be either a read only memory programmed with all available on-screen display messages or may be a read/write memory, the on-screen display messages being alterable by the processor PRO. The output DSP2 from the auxiliary page memory APM is fed to a multiplexer MUX whose output provides the signal DSP to the character generator CG. The multiplexer MUX is arranged to select the data for display from either the page memory PM or the auxiliary page memory APM. This is done on the basis of selecting a row for display either from the memory PM or from the memory APM. For each row a bit is stored in the memory PM which specifies whether the row should be displayed from the memory PM or the memory APM. This bit is set by the processor PRO via the connection X. The memory interface circuit MIC applies the bit associated with the row to be displayed to a latch L which is clocked by a signal T4 at the row frequency. The signal T4 is derived from the timing circuit TC. The output OSD of the latch L controls the multiplexer MUX to select the data to be displayed from either the page memory PM or the auxiliary memory APM.

In this way the data which has been acquired by the data acquisition circuit DAC remains stored in the memory PM and the on-screen display information is derived from the auxiliary memory APM and read directly into the character generator through the multiplexer MUX rather than being read into the page memory PM and replacing the teletext data which has previously been acquired. As a result there is no delay in reinstating the teletext data when the on-screen display is dispensed with since the teletext data which has been replaced by the on-screen display data is retained in the memory PM. This is in contrast to the arrangement shown in US Patent No. 4633297 where the on-screen display data is read into the dynamic RAM which forms the page memory and replaces the teletext data. This means that the teletext data where replaced by the on-screen display can

only be restored when the cycle of transmitted data returns to the selected page. This may entail a delay of up to 25 seconds before the information is restored and the page can be displayed correctly.

An alternative approach would be to use a single page memory PM but to program the processor to transfer to temporary memory means the teletext data which was to be overwritten by the on-screen display data. This data could then be written back into the page memory PM without having to wait for the appropriate part of the cycle of teletext data transmission. However this increases the complexity required from the processor and requires it to have a high operating speed. Both of these factors would increase cost.

Within the page memory PM is data information contained in row 25 of the teletext page. Row 25 is not displayed on the display device but contains a number of control characters. The last 14 characters of row 25 contain the row attributes. These comprise a 3 bit number for each teletext row and the areas at the top and bottom of the screen outside the normal text display area. These 3 bit numbers define the default background colour for the row. In addition they contain a bit for each text row to indicate whether the row should be displayed from the page memory PM or from the auxiliary memory APM. It is this last bit which is set to define from which memory the display is derived for each row. The state of this bit determines whether the latch L becomes set. The state of the output of the latch L causes the multiplexer MUX to select data from the desired memory. Figure 2 shows the layout of the memory corresponding to the last 14 columns of row 25 which contains the row attributes. These contain a bit for each text row to indicate whether the rows should be displayed from the normal or the auxiliary memory and a 3 bit number for each teletext row and for the areas at the top and bottom of the screen outside the normal text display area to define the default background colour for that row. Bit N/S defines whether text for the row comes from the memory PM or from the auxiliary memory APM. Thus for each row bit N/S is set to specify the memory from which the data is read out via the multiplexer MUX by the processor PRO over the connection X according to whether teletext data or on-screen display data is to be displayed.

The arrangement shown in Figure 1 is capable of inserting on-screen display messages from the auxiliary memory APM but is limited to selecting data from the memory PM or from the auxiliary memory APM for a complete row, that is in one display row information from only one of the memories PM and APM can be displayed.

Figure 3 shows an arrangement in which boxed messages as illustrated in Figure 4 can be displayed, that is the data for display can be taken from both the memory PM and the auxiliary memory APM for the

same row.

When an on-screen display is required the processor PRO through the interface unit INT produces a signal SC which is the display character on which the on-screen display message is to start. This is fed to a first input of a comparator COMP. A second input of the comparator COMP receives a signal DC from the timing control circuit ATC. When the signal DC, which represents the current display character, is equal to SC, which represents the display character at which the on-screen display is to start, the comparator COMP produces an output which sets a latch OSDL. At the same time it starts a counter CNTR. The processor PRO2 also produces via the interface INT2 a signal W which defines the width in character spaces of the area of the screen on which the on-screen display message is to be displayed. This signal W is fed to the counter CNTR to pre-set it to a given count. A clock signal SCL at the character rate is fed to the counter and is enabled by the signal from the comparator COMP. The counter CNTR then counts down to zero when it resets the latch OSDL. The output of the latch OSDL which produces the signal OSD controls the multiplexer MUX. In this way the data for display is selected from either the memory PM or the auxiliary memory APM.

This procedure could of course be replicated so that more than one box is displayed on the screen at any one time, the information being selected from the auxiliary memory APM when the box is defined.

A further refinement of the invention which can be applied to the arrangement shown in Figure 1 is to allocate a bit in the page memory PM to each character in each row. This will enable either teletext or on-screen display data to be selected on a character by character basis. This will, however, require a greater memory capacity for the page memory PM but will give a greater flexibility of display without requiring significantly greater complexity for the processor PRO.

The arrangements described with respect to the Figures enable the selective display of either teletext data or on-screen display data and enable return to the teletext data without having to re-write the display memory PM. Thus the teletext data is not lost and it is not necessary to wait until the next cycle of transmission of teletext data in order to restore the full page after deleting an on-screen display message.

From reading the present disclosure, other modifications will be apparent to persons skilled in the art. Such modifications may involve other features which are already known in the desired and use of television receivers including teletext decoders and devices and component parts thereof and which may be used instead of or in addition to features already described herein. Although claims have been formulated in this application to particular combinations of features, it should be understood that the scope of the disclosure

of the present application also includes any novel feature or any novel combination of features disclosed herein either explicitly or implicitly or any generalisation thereof, whether or not it relates to the same invention as presently claimed in any claim and whether or not it mitigates any or all of the same technical problems as does the present invention. The applicants hereby give notice that new claims may be formulated to such features and/or combinations of such features during the prosecution of the present application or of any further application derived therefrom.

Claims

1. A television receiver including a teletext processor including character generator means and teletext page memory means for receiving, decoding and displaying teletext data, means for generating an on-screen message display, the on-screen message display generating means including a further memory means for storing the required data for the on-screen message display and microprocessor means for controlling the teletext processor and the on-screen message display generating means, characterised by selection means for selectively reading data from the display memory and the further memory to the character generator.
2. A television receiver as claimed in Claim 1, in which the selection means is controlled by data read from given locations in the teletext page memory.
3. A television receiver as claimed in Claim 2, in which the data is stored in row 25 of the teletext data page and comprises a single bit for each row of the displayed page which defines from which memory the data for display should be read.
4. A television receiver as claimed in any preceding claim in which the microprocessor means produces a first signal which defines the column at which an on-screen display message starts and a second signal which defines the width of the on-screen display message.

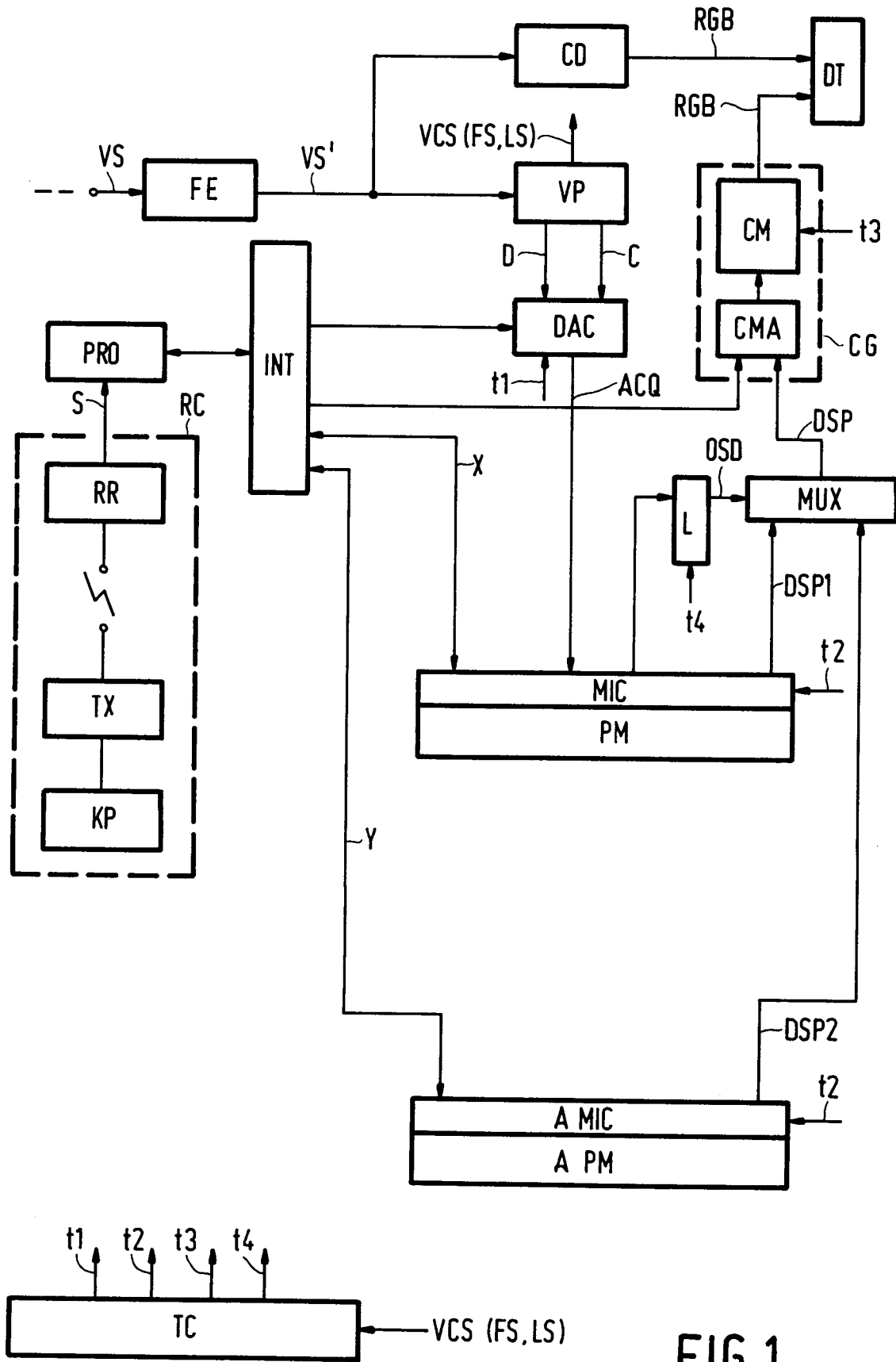

FIG. 1

Column	D7	D6	D5	D4	D3	D2	D1	D0
10	—	Bottom A2	Bottom A1	Bottom A0	—	Top A2	Top A1	Top A0
11	Row 1 N/S	Row 1 A2	Row 1 A1	Row 1 A0	Row 0 N/S	Row 0 A2	Row 0 A1	Row 0 A0
12	Row 3 N/S	Row 3 A2	Row 3 A1	Row 3 A0	Row 2 N/S	Row 2 A2	Row 2 A1	Row 2 A0
13	Row 5 N/S	Row 5 A2	Row 5 A1	Row 5 A0	Row 4 N/S	Row 4 A2	Row 4 A1	Row 4 A0
14	Row 7 N/S	Row 7 A2	Row 7 A1	Row 7 A0	Row 6 N/S	Row 6 A2	Row 6 A1	Row 6 A0
15	Row 9 N/S	Row 9 A2	Row 9 A1	Row 9 A0	Row 8 N/S	Row 8 A2	Row 8 A1	Row 8 A0
16	Row 11 N/S	Row 11 A2	Row 11 A1	Row 11 A0	Row 10 N/S	Row 10 A2	Row 10 A1	Row 10 A0
17	Row 13 N/S	Row 13 A2	Row 13 A1	Row 13 A0	Row 12 N/S	Row 12 A2	Row 12 A1	Row 12 A0
18	Row 15 N/S	Row 15 A2	Row 15 A1	Row 15 A0	Row 14 N/S	Row 14 A2	Row 14 A1	Row 14 A0
19	Row 17 N/S	Row 17 A2	Row 17 A1	Row 17 A0	Row 16 N/S	Row 16 A2	Row 16 A1	Row 16 A0
20	Row 19 N/S	Row 19 A2	Row 19 A1	Row 19 A0	Row 18 N/S	Row 18 A2	Row 18 A1	Row 18 A0
21	Row 21 N/S	Row 21 A2	Row 21 A1	Row 21 A0	Row 20 N/S	Row 20 A2	Row 20 A1	Row 20 A0
22	Row 23 N/S	Row 23 A2	Row 23 A1	Row 23 A0	Row 22 N/S	Row 22 A2	Row 22 A1	Row 22 A0
23	—	—	—	—	Row 24 N/S	Row 24 A2	Row 24 A1	Row 24 A0

FIG. 2

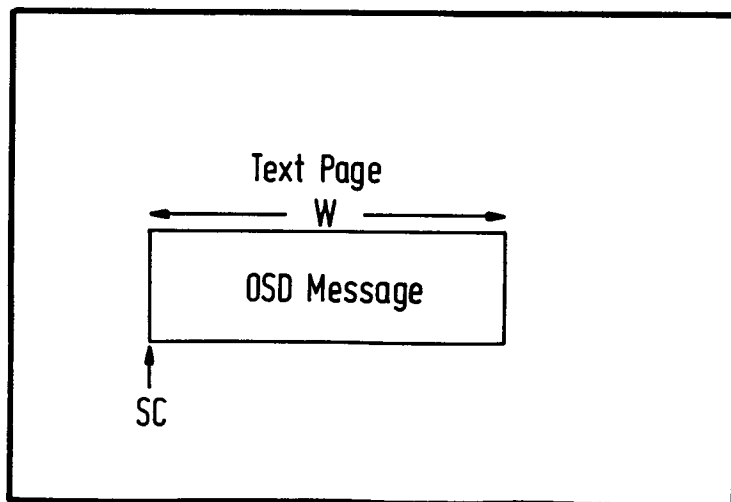

FIG. 4

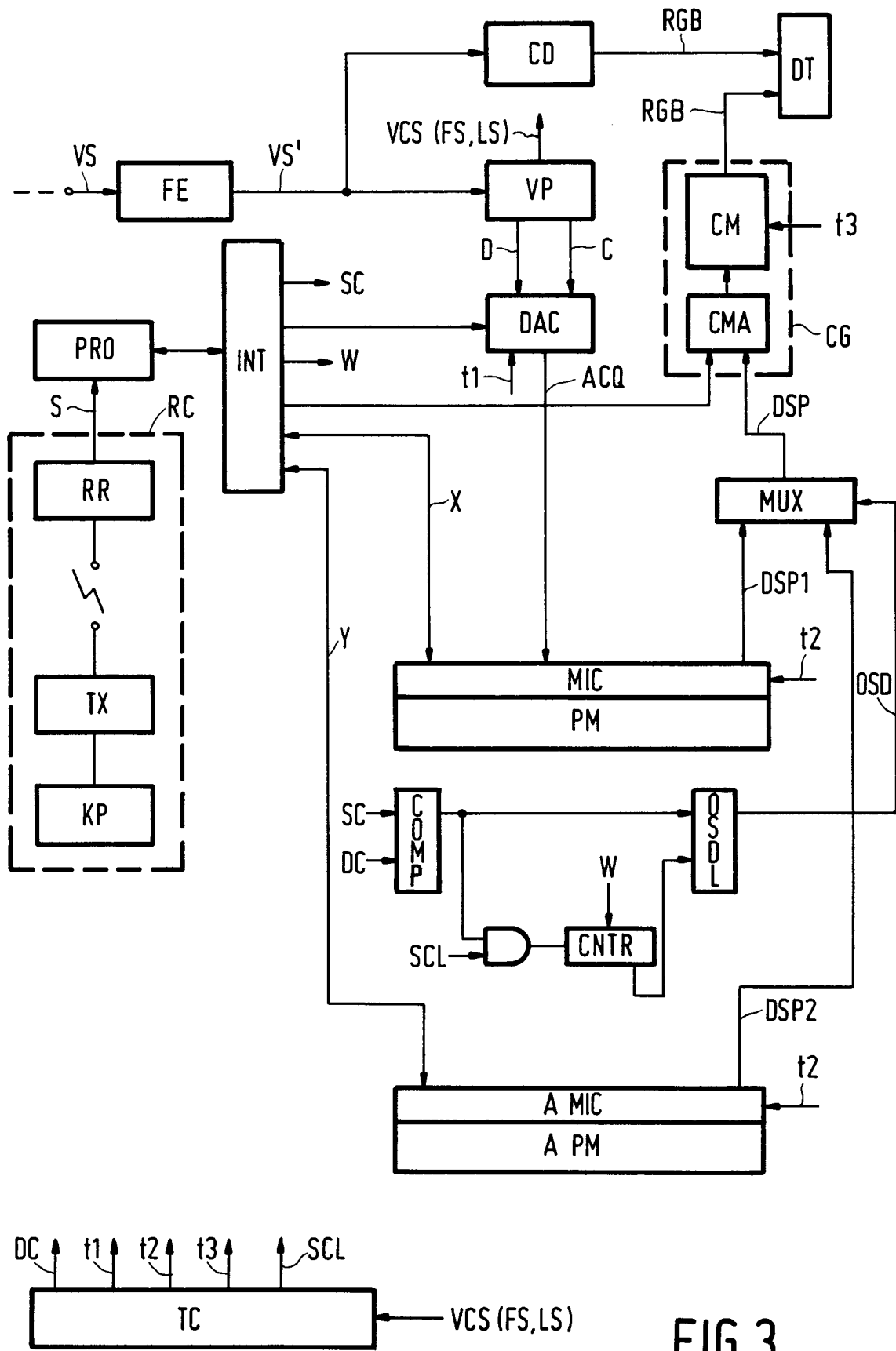

FIG. 3



European Patent
Office

EUROPEAN SEARCH REPORT

Application Number

EP 93 20 0003

DOCUMENTS CONSIDERED TO BE RELEVANT			
Category	Citation of document with indication, where appropriate, of relevant passages	Relevant to claim	CLASSIFICATION OF THE APPLICATION (Int. Cl.5)
D,Y	EP-A-0 362 940 (N.V. PHILIPS GLOEILAMPENFABRIEKEN) * column 4, line 50 - column 6, line 45; figure 1 *	1,2,4	H04N7/00 H04N7/087 G09G1/16
Y	GB-A-2 244 897 (GOLDSTAR CO.,LTD) * page 6, line 27 - page 9, line 1; figure 1 * * page 9, line 25 - page 11, line 18 *	1,2	
D,Y	US-A-4 633 297 (SKERLOS ET AL.) * column 4, line 12 - line 40; figure 3 *	4	
Y	GB-A-2 240 447 (GOLDSTAR CO.,LTD) * page 4, line 12 - page 5, line 10; figure 1 *	1	
-----			TECHNICAL FIELDS SEARCHED (Int. Cl.5)
			H04N G09G
The present search report has been drawn up for all claims			
Place of search BERLIN		Date of completion of the search 01 APRIL 1993	Examiner MATERNE A.
CATEGORY OF CITED DOCUMENTS X : particularly relevant if taken alone Y : particularly relevant if combined with another document of the same category A : technological background O : non-written disclosure P : intermediate document		T : theory or principle underlying the invention E : earlier patent document, but published on, or after the filing date D : document cited in the application L : document cited for other reasons & : member of the same patent family, corresponding document	

EPO FORM 1503 01.92 (F0001)