



US 20140277510A1

(19) **United States**

(12) **Patent Application Publication**
Robinson et al.

(10) **Pub. No.: US 2014/0277510 A1**

(43) **Pub. Date: Sep. 18, 2014**

(54) **EXPANDABLE VERTEBRAL BODY REPLACEMENT DEVICE, SYSTEM, AND METHODS**

(60) Provisional application No. 61/802,360, filed on Mar. 15, 2013.

Publication Classification

(71) Applicants: **James C. Robinson**, Atlanta, GA (US);
John E. Pendleton, Atlanta, GA (US)

(51) **Int. Cl.**
A61F 2/44 (2006.01)

(72) Inventors: **James C. Robinson**, Atlanta, GA (US);
John E. Pendleton, Atlanta, GA (US)

(52) **U.S. Cl.**
CPC *A61F 2/44* (2013.01)
USPC *623/17.16*

(73) Assignee: **SPECTRUM SPINE IP HOLDINGS, LLC**, Atlanta, GA (US)

(57) **ABSTRACT**

(21) Appl. No.: **14/216,893**

An expandable vertebral body replacement is presented. The device has an inner and outer housing longitudinally moveable on one-another which locks in place using a retention member. This can be locked or fortified by several described options. Also presented is a method for expanding said device embodiments and a system for an expandable vertebral body replacement.

(22) Filed: **Mar. 17, 2014**

Related U.S. Application Data

(63) Continuation-in-part of application No. 14/216,513, filed on Mar. 17, 2014.

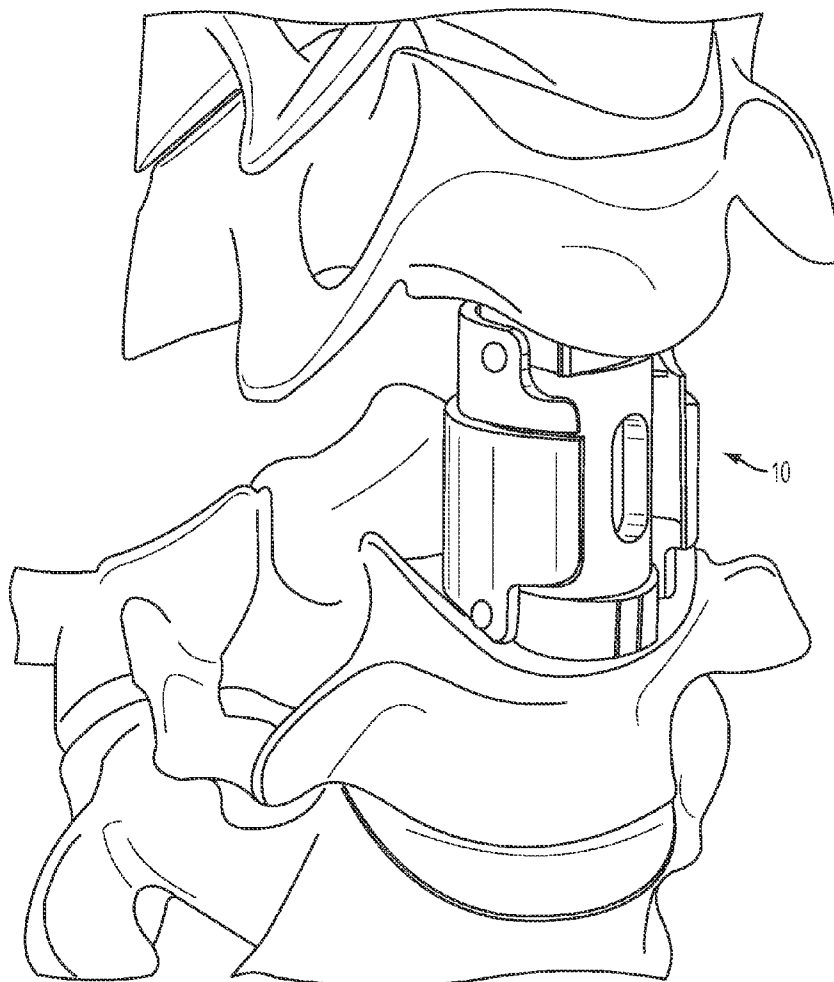

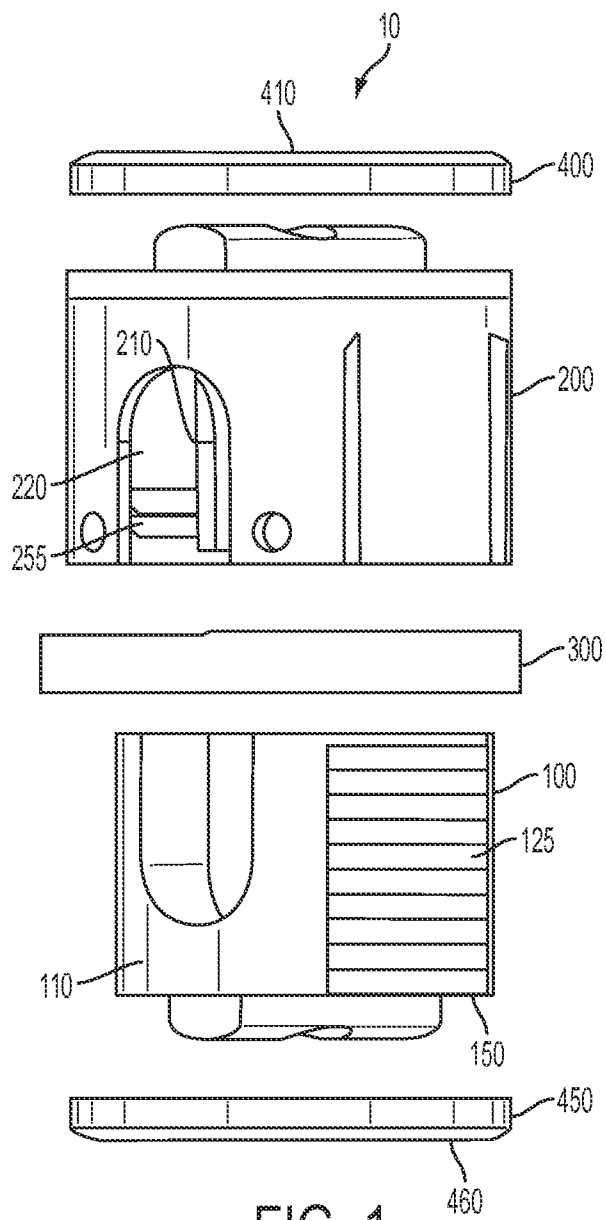

FIG. 1

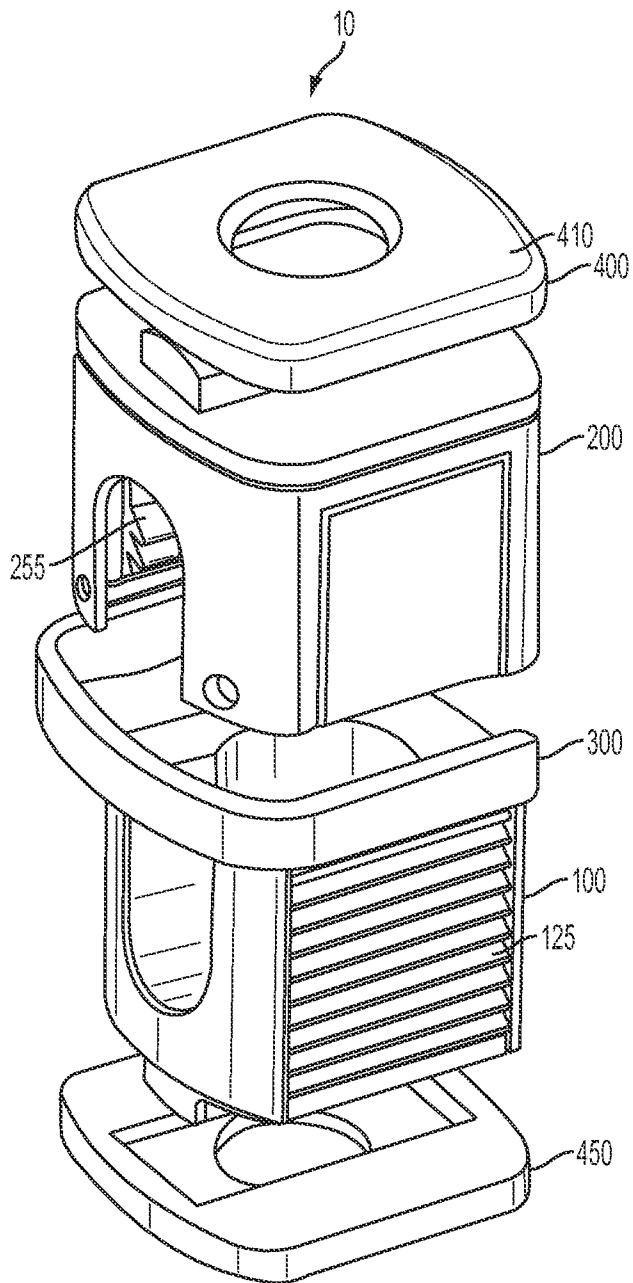

FIG. 2

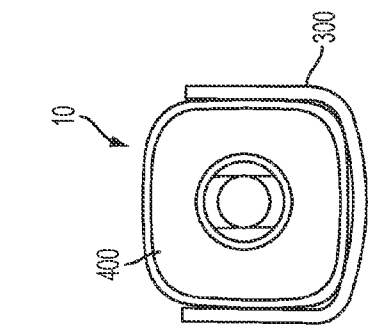

FIG. 5

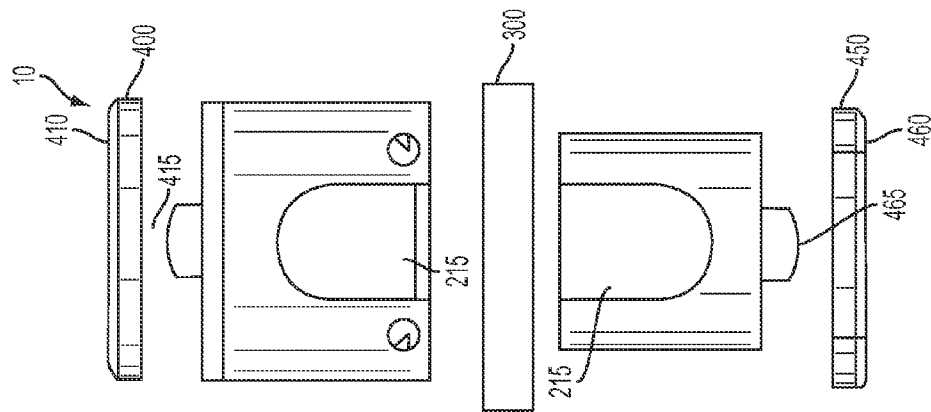

FIG. 4

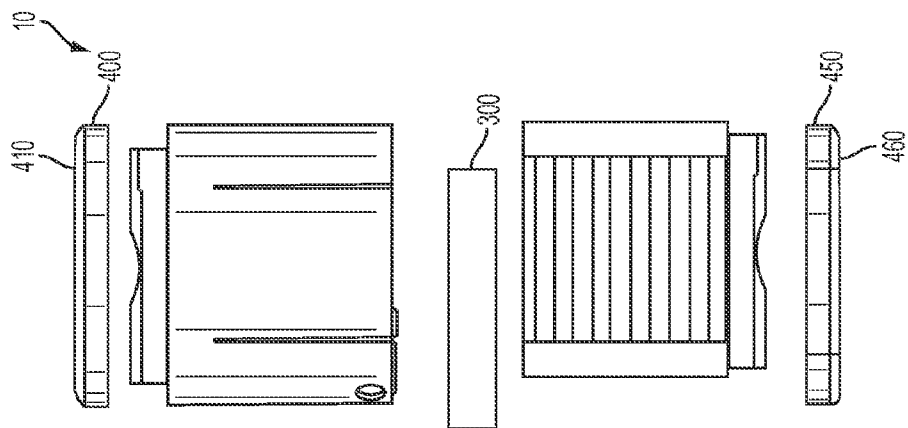

FIG. 3

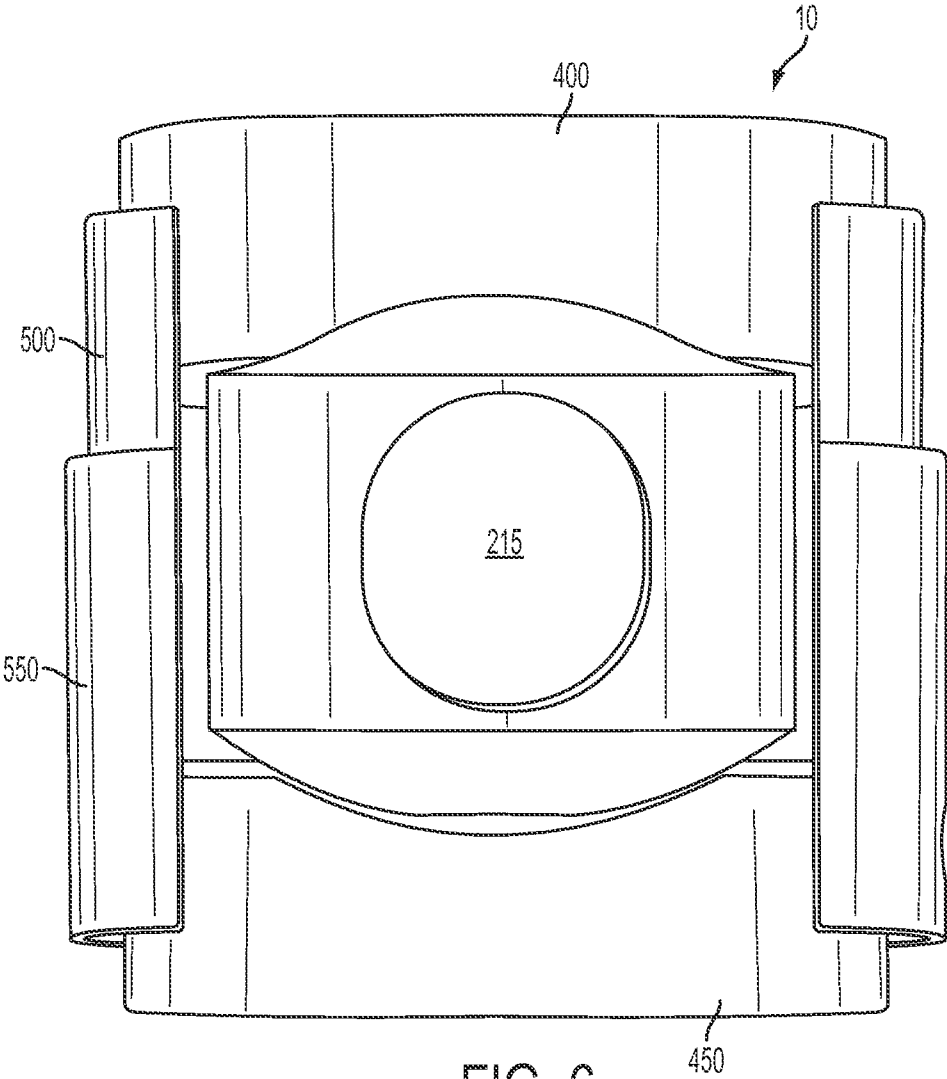

FIG. 6

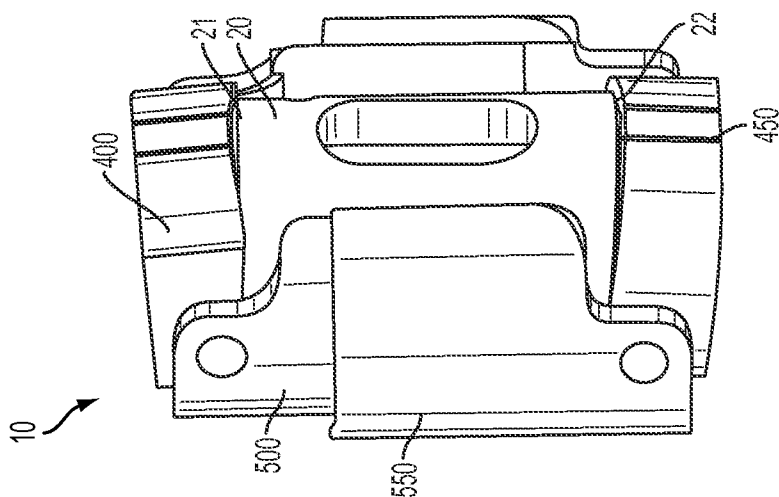

FIG. 7

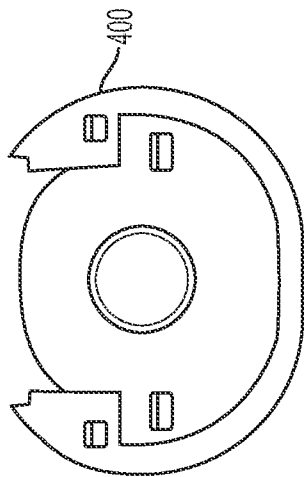

FIG. 8

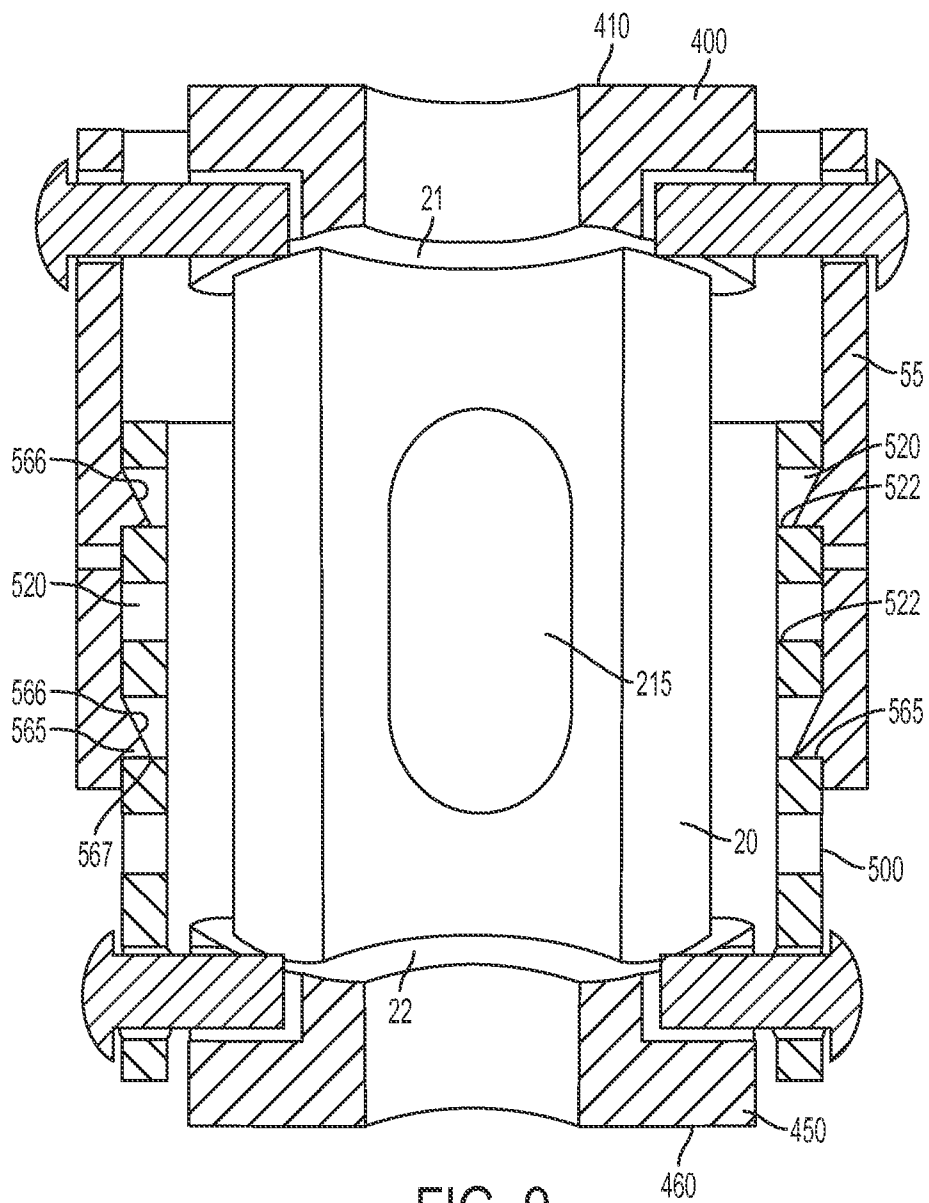

FIG. 9

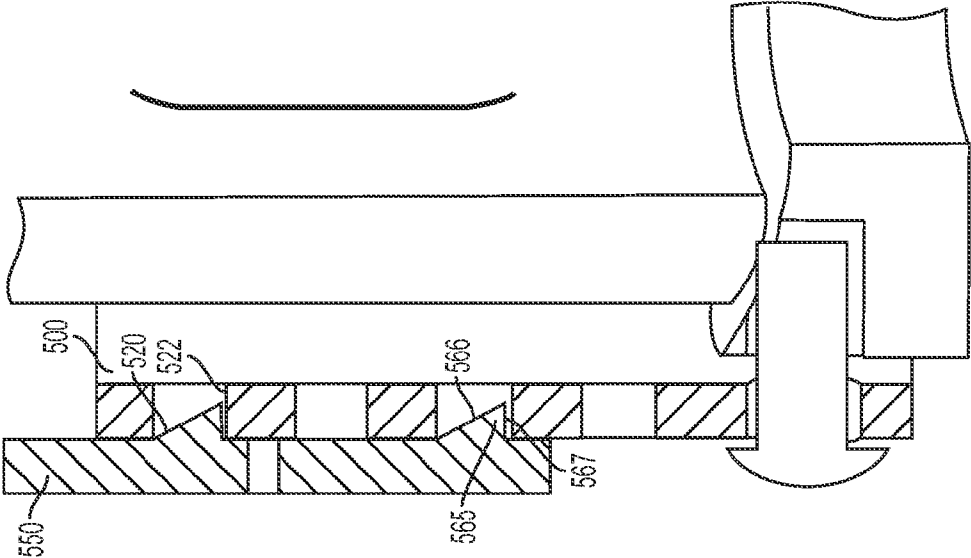

FIG. 10

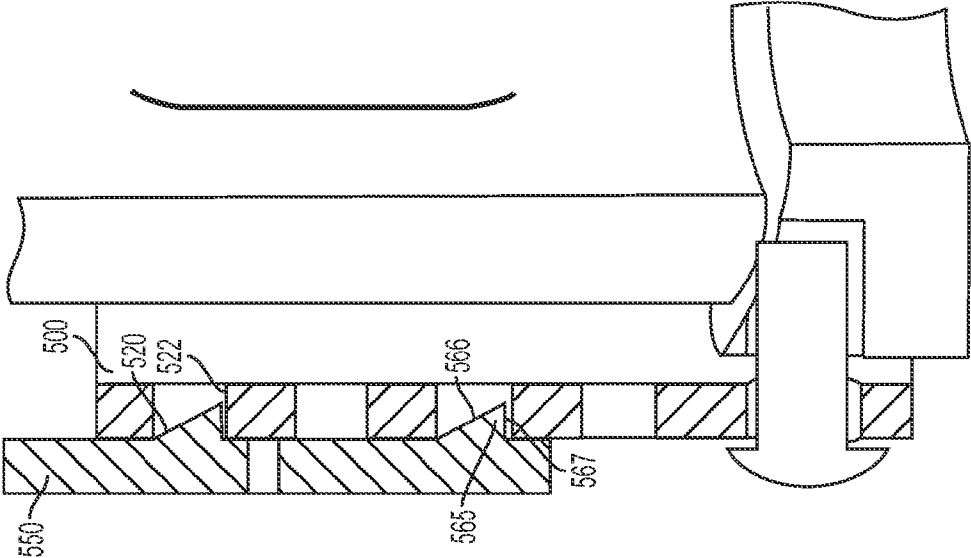

FIG. 11

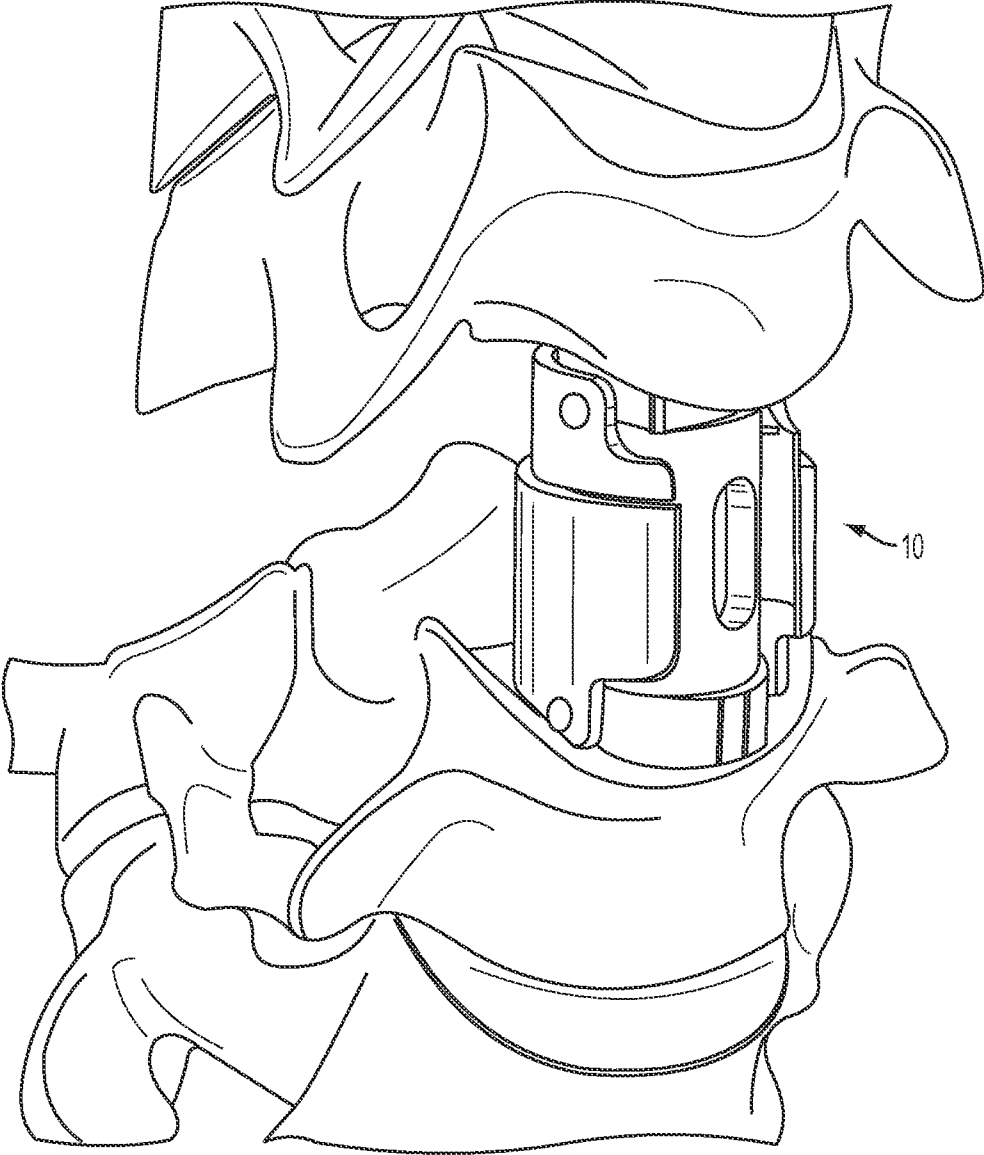

FIG. 12

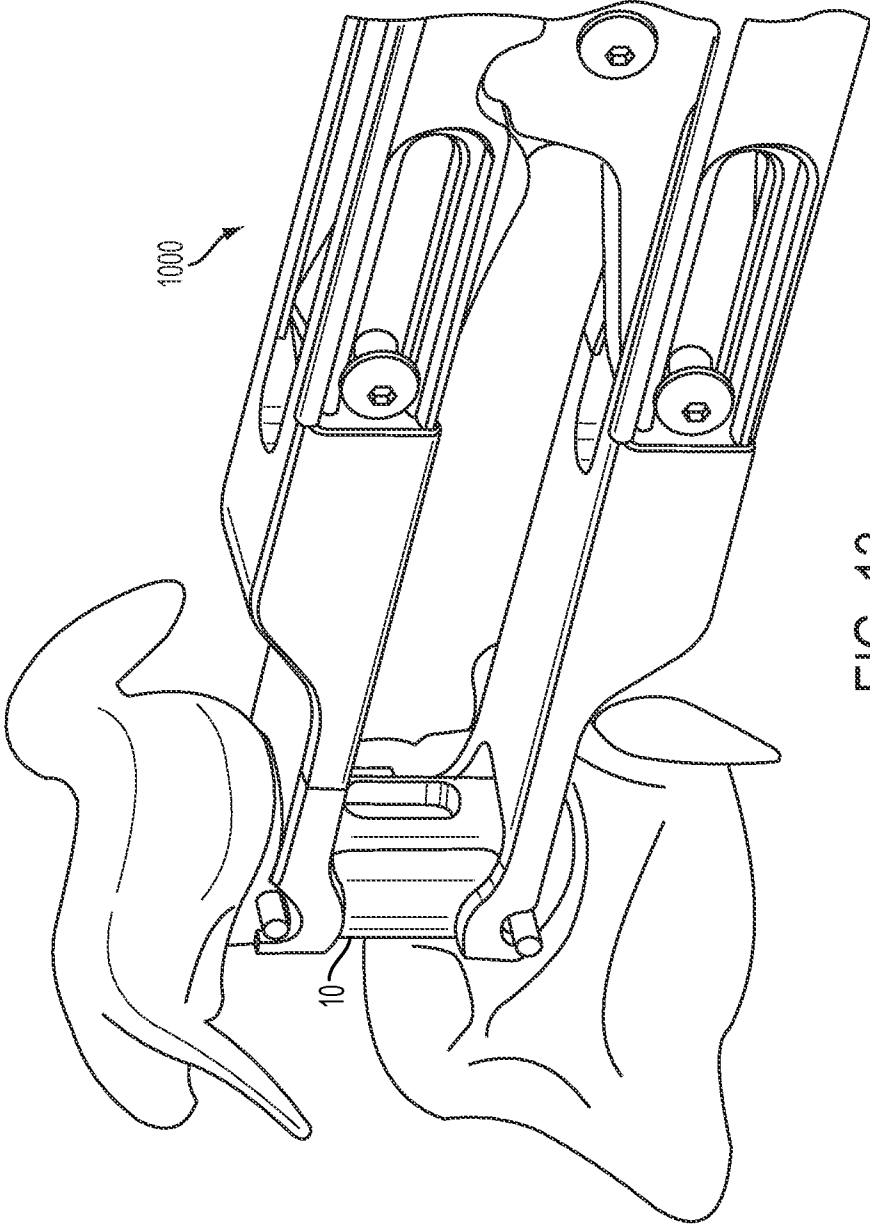

FIG. 13

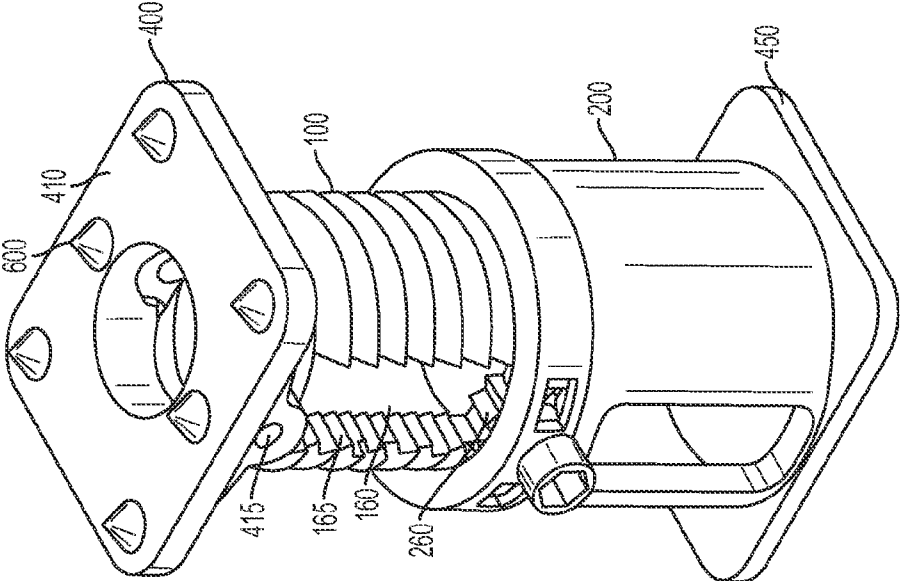

FIG. 15

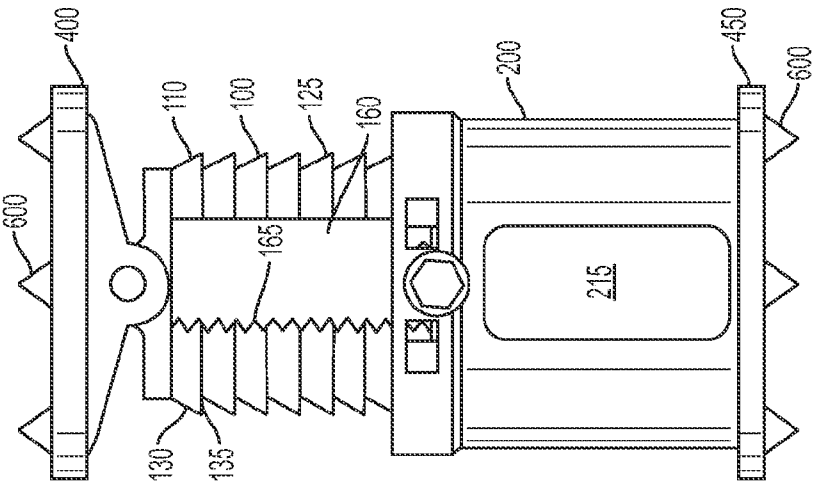

FIG. 14

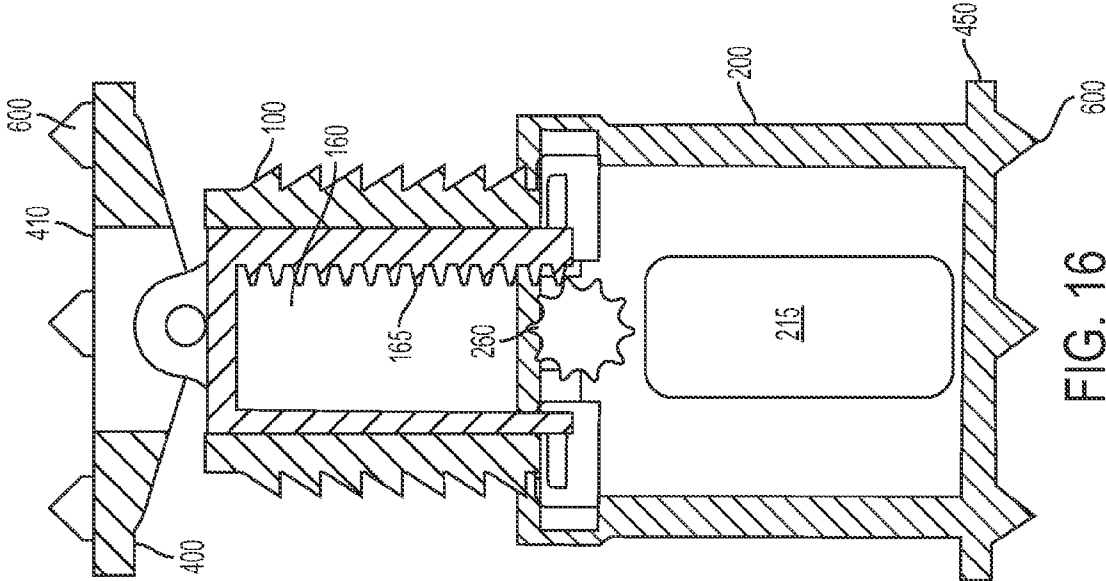

FIG. 17

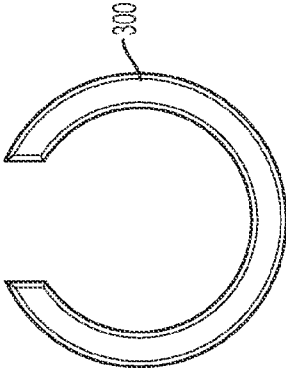
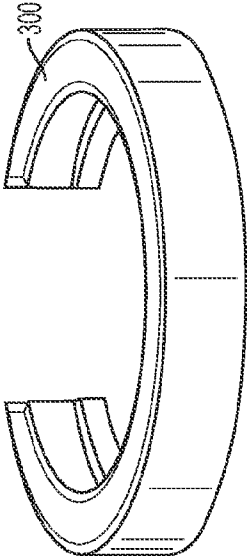

FIG. 18



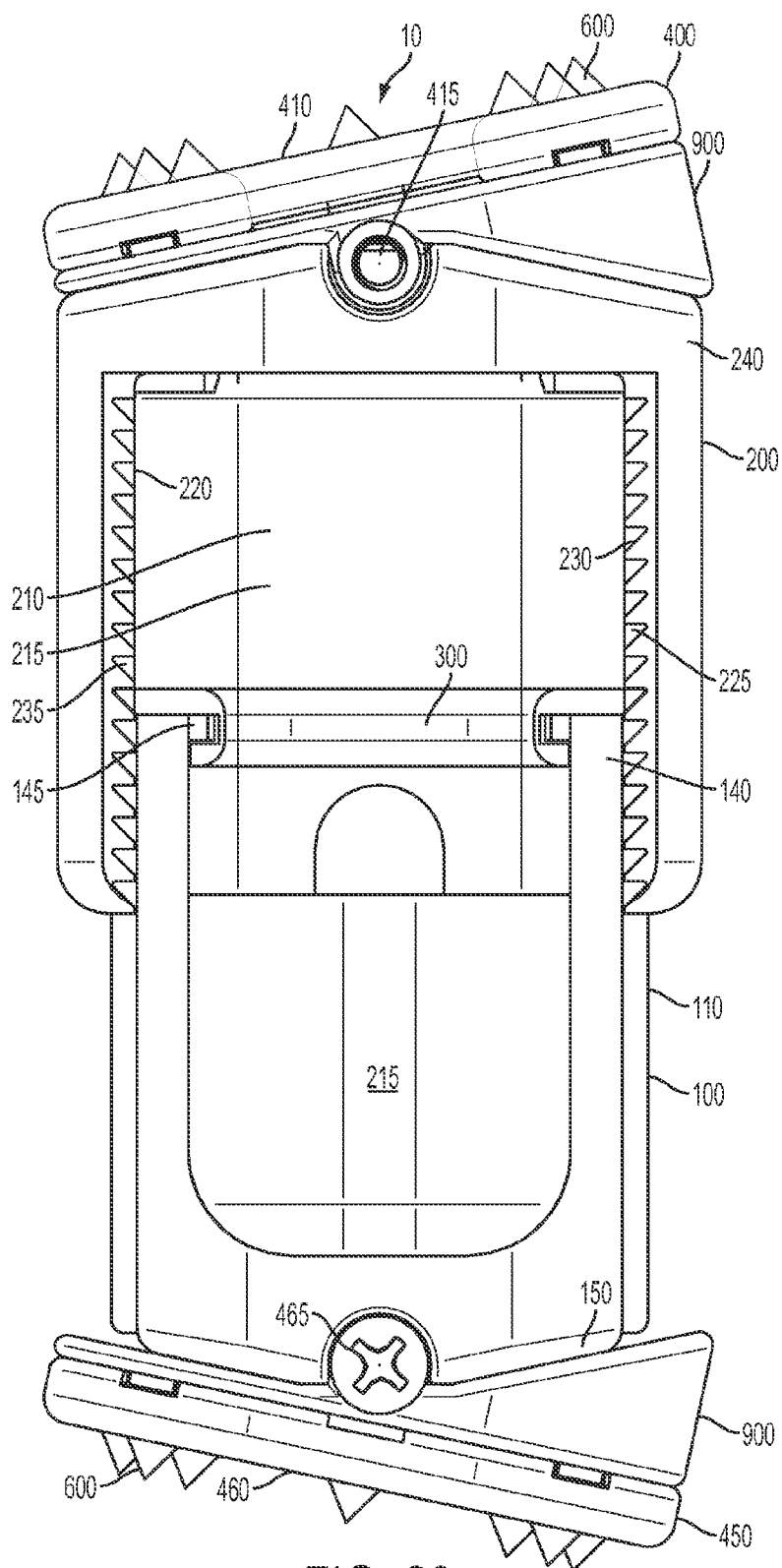

FIG. 20

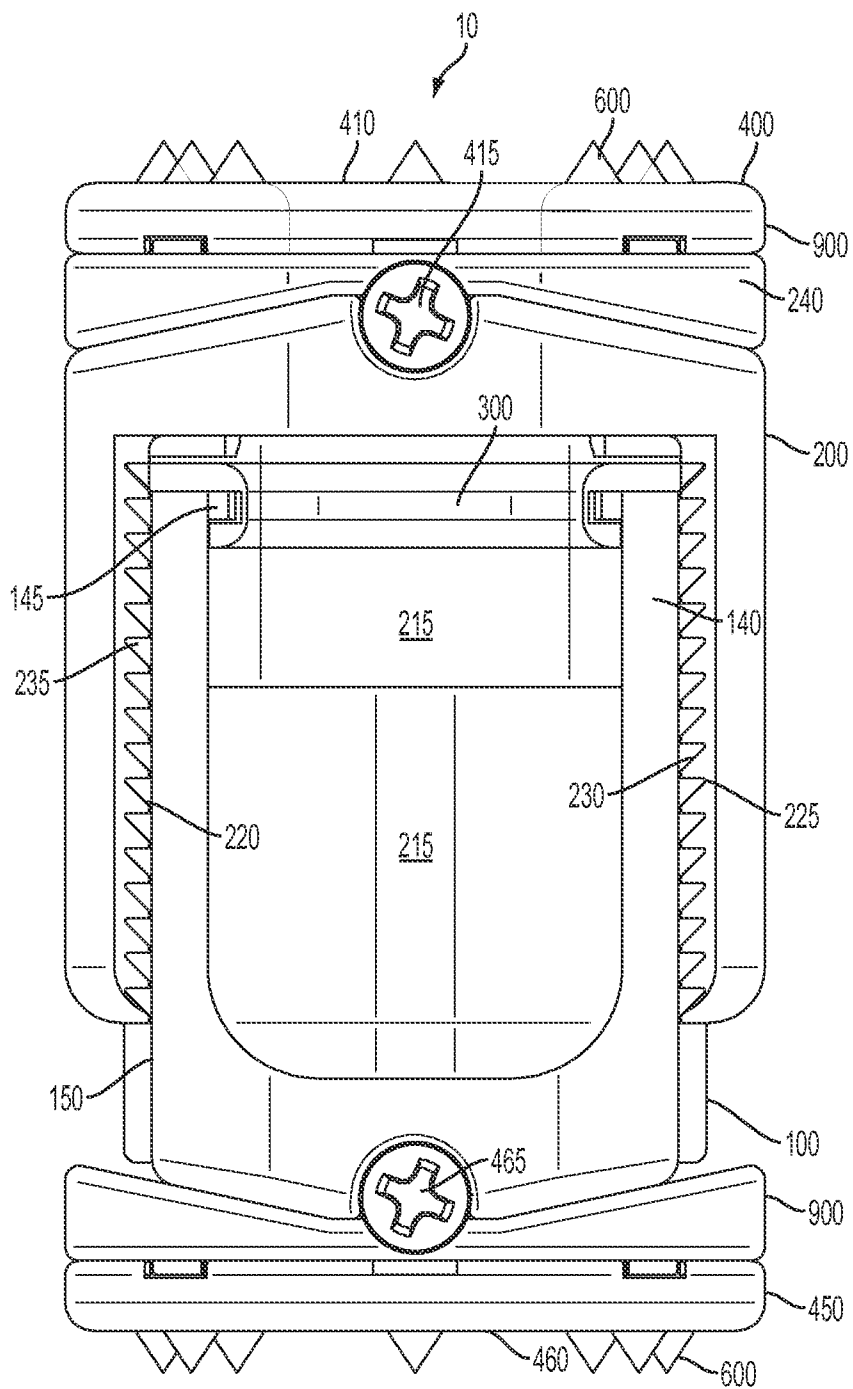

FIG. 21

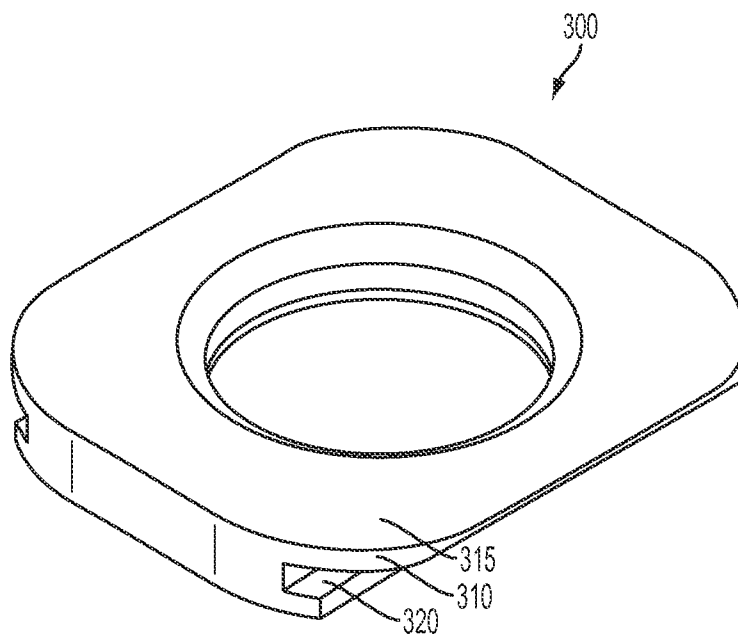

FIG. 23

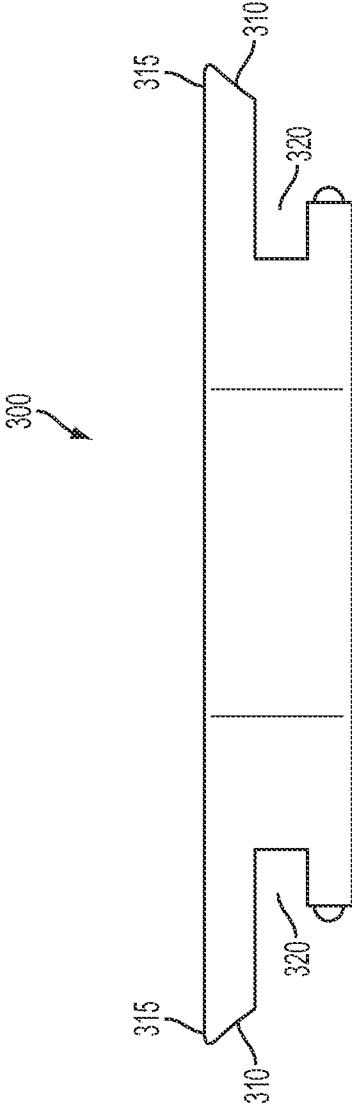

FIG. 24

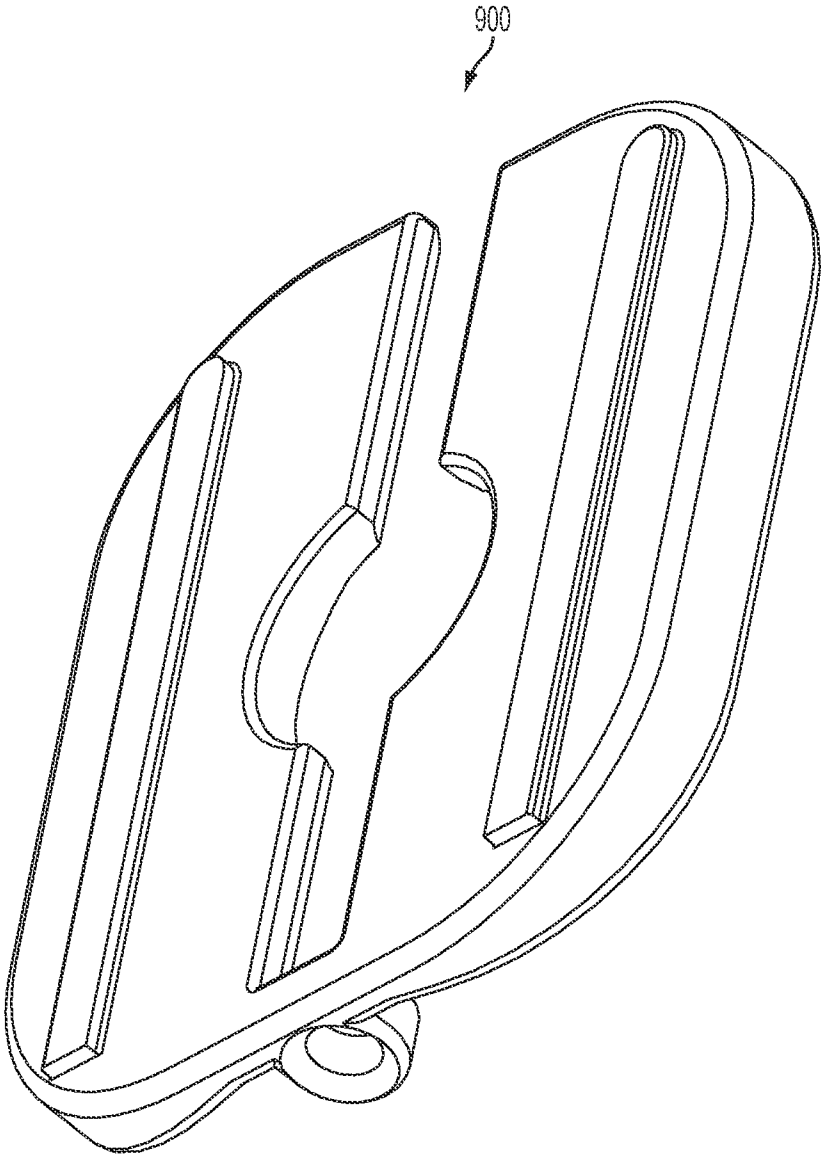

FIG. 25

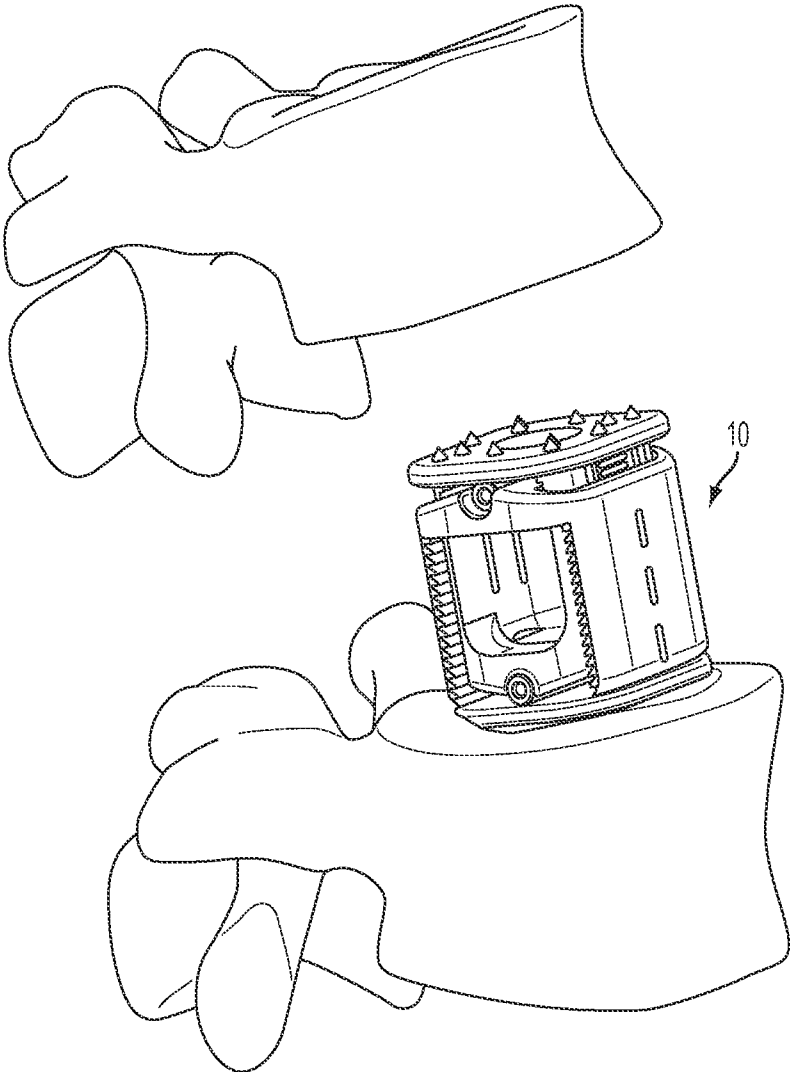

FIG. 26

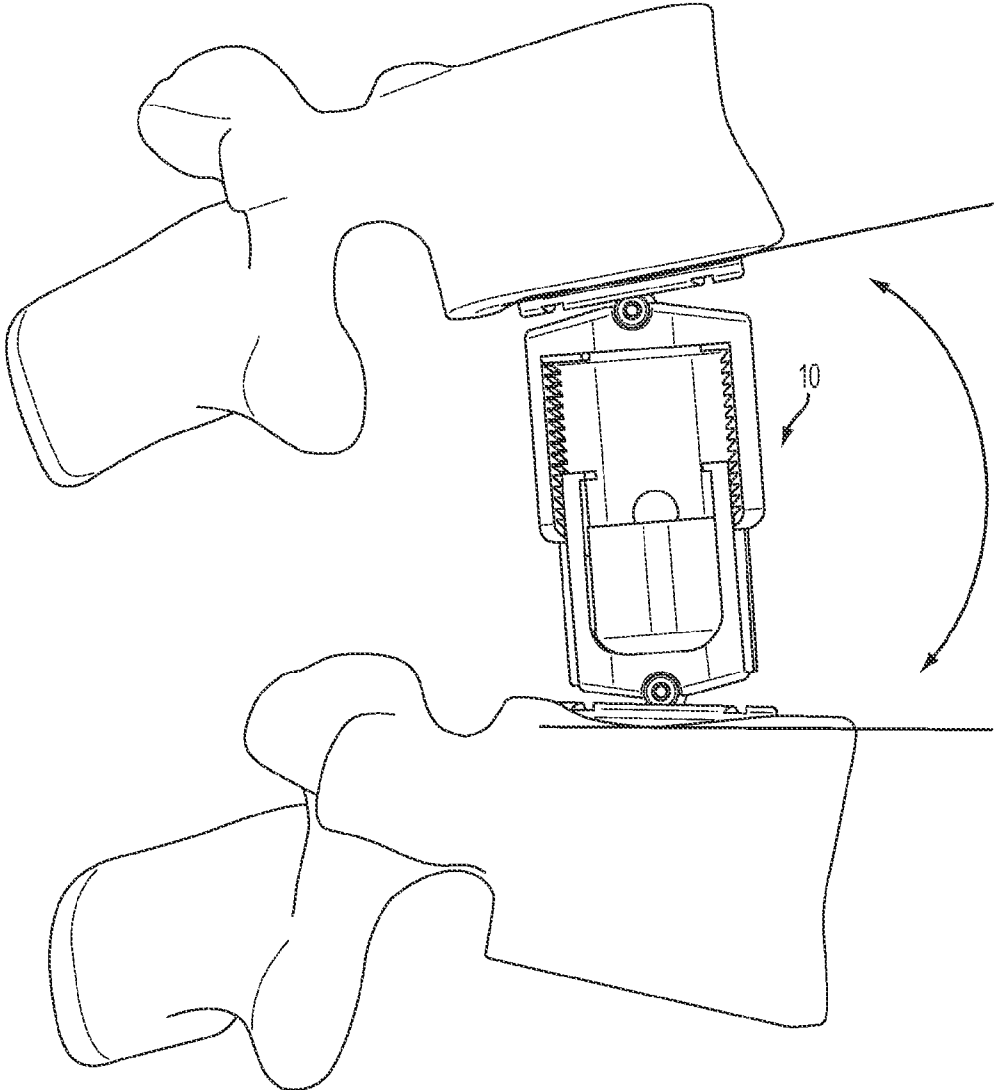

FIG. 27

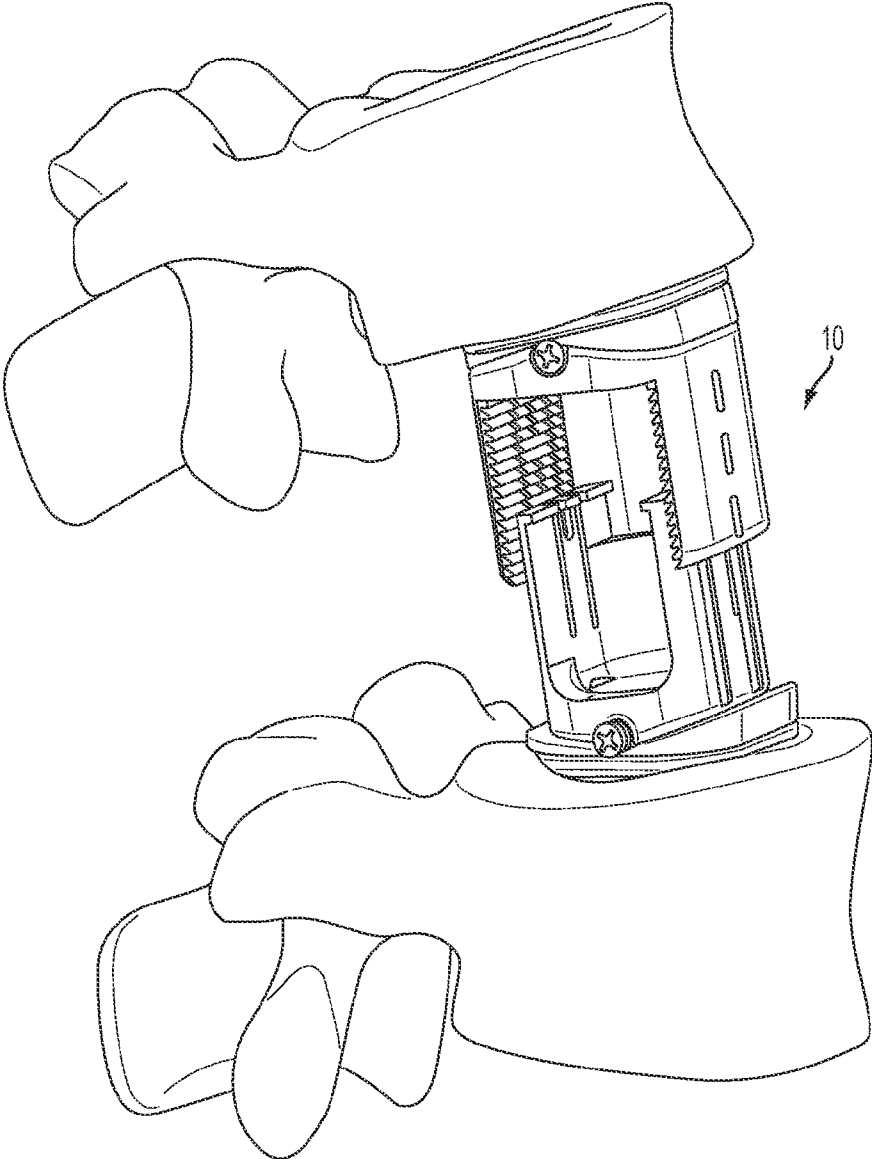

FIG. 28

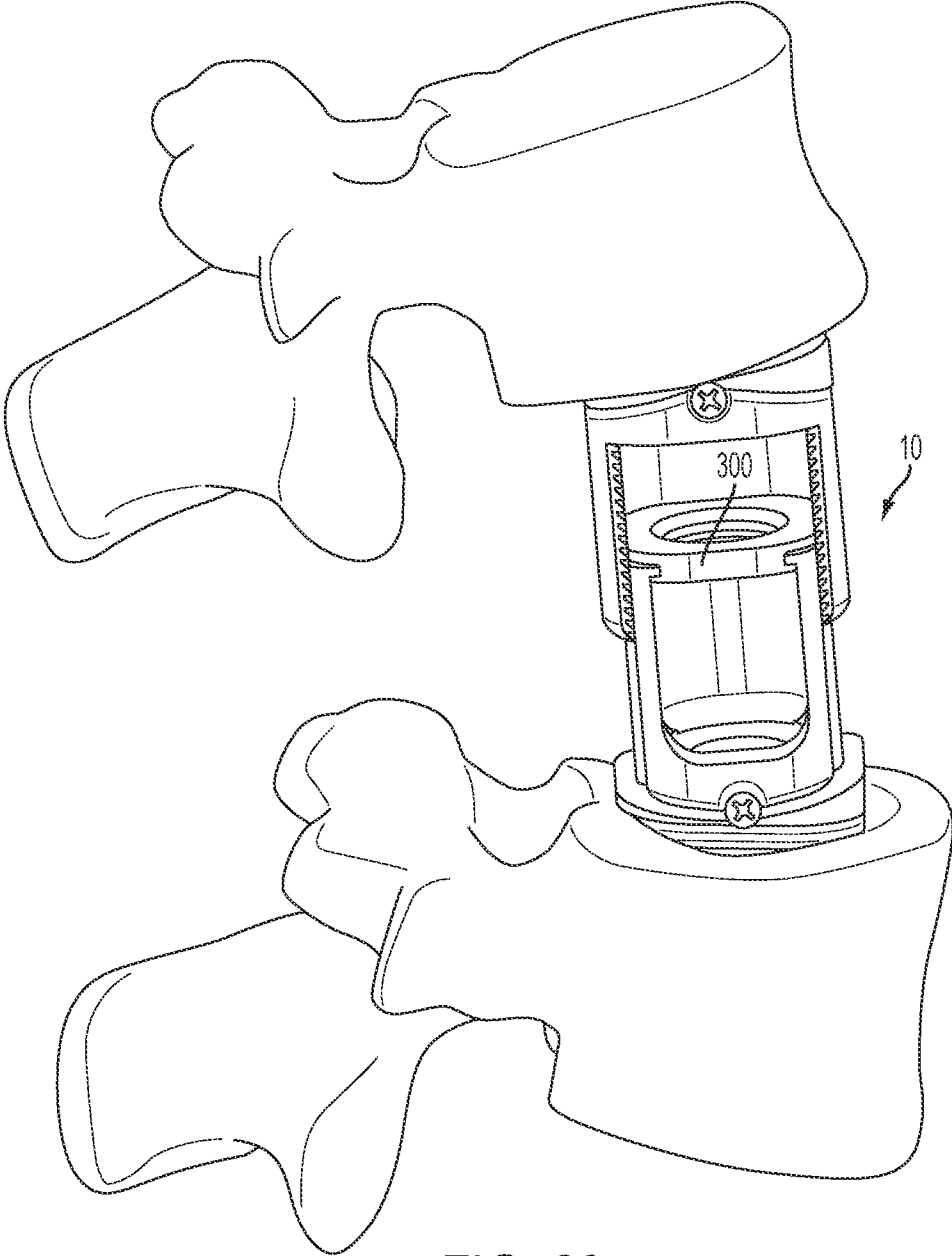

FIG. 29

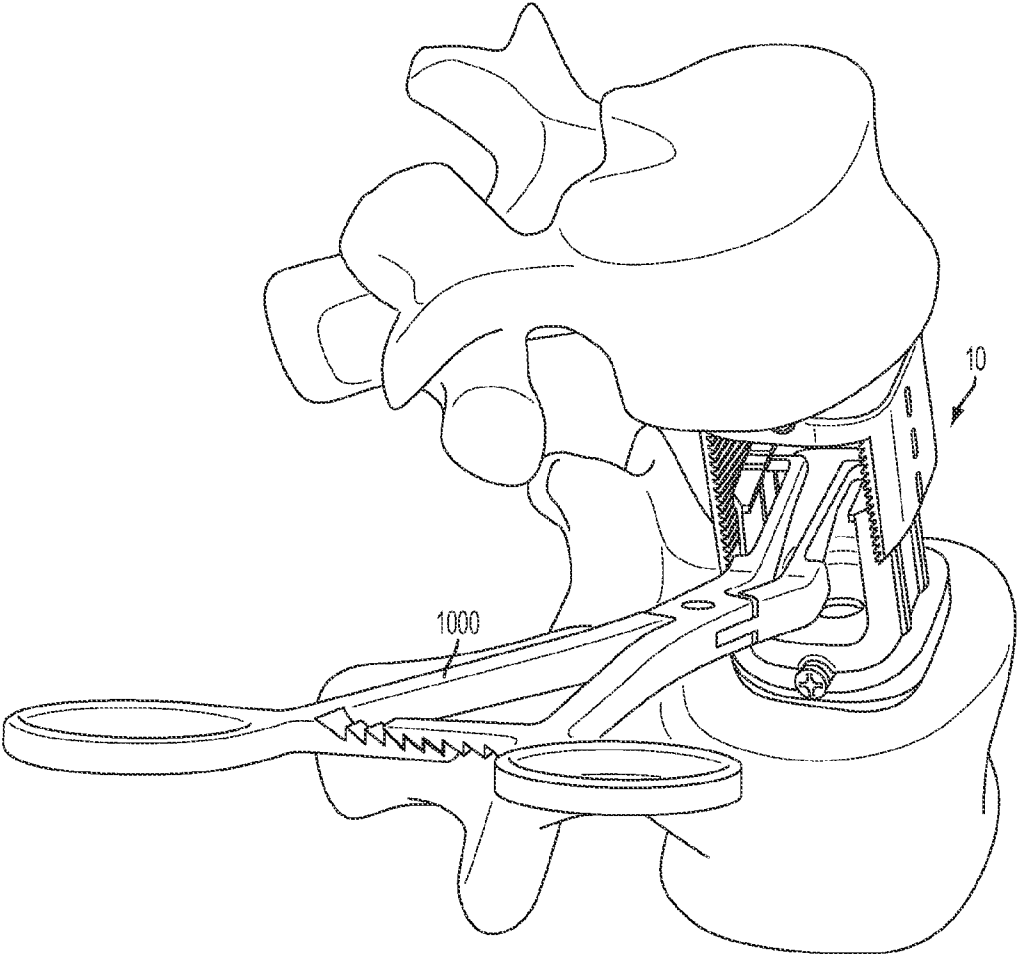

FIG. 30

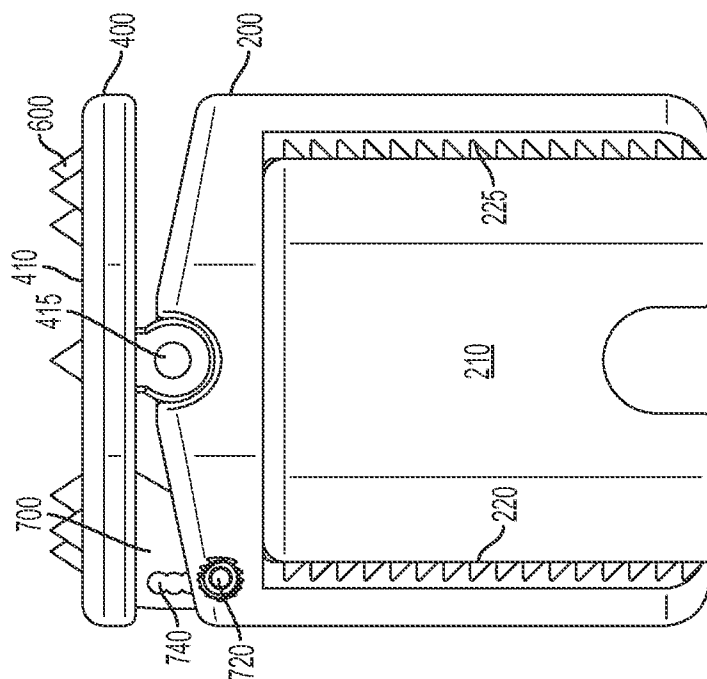

FIG. 31

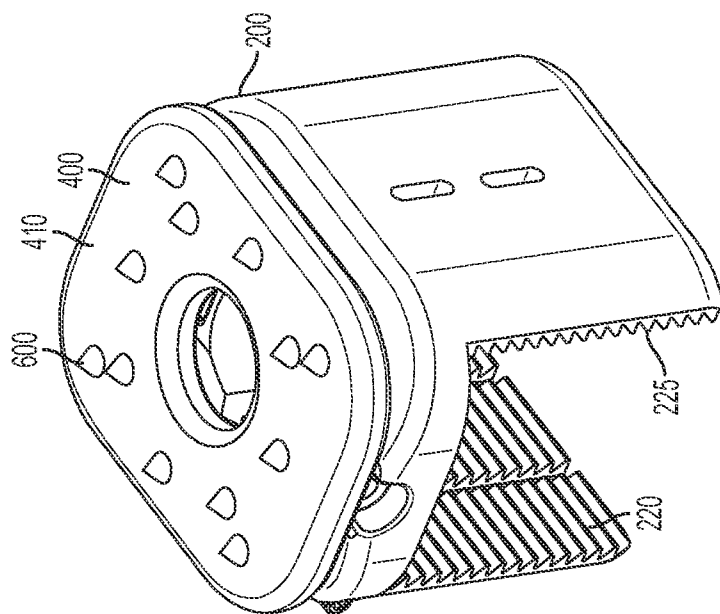

FIG. 32

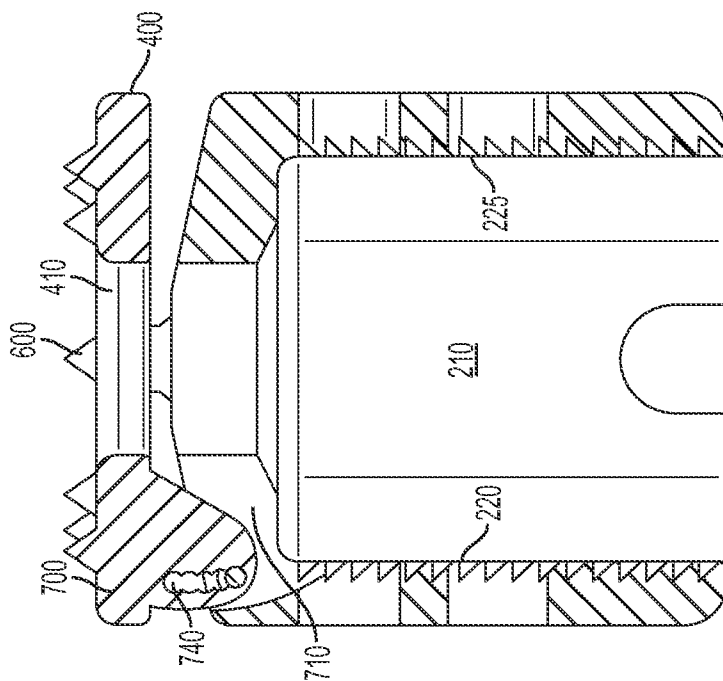

FIG. 34

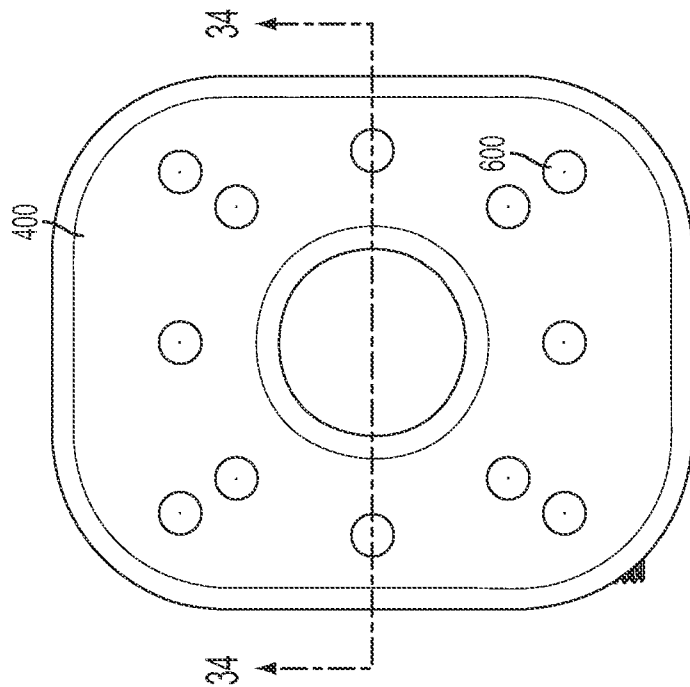

FIG. 33

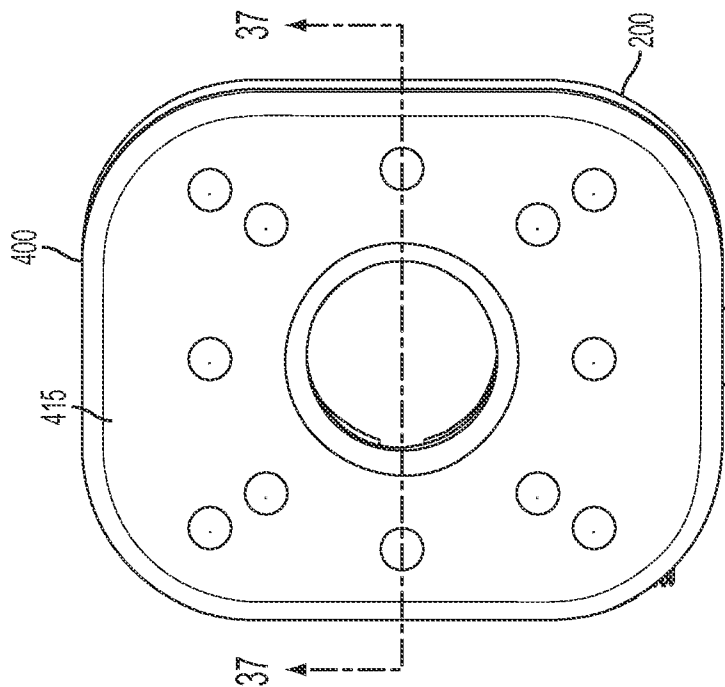

FIG. 36

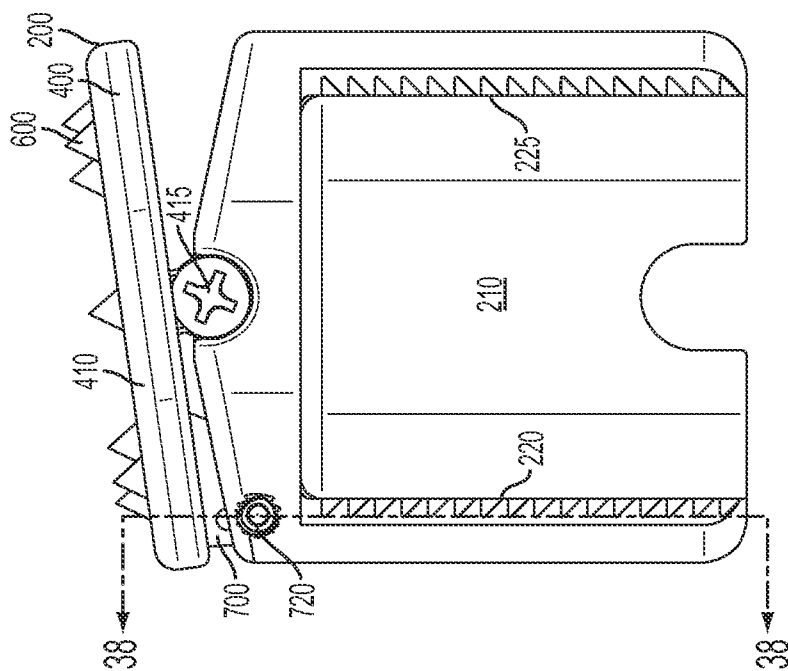

FIG. 35

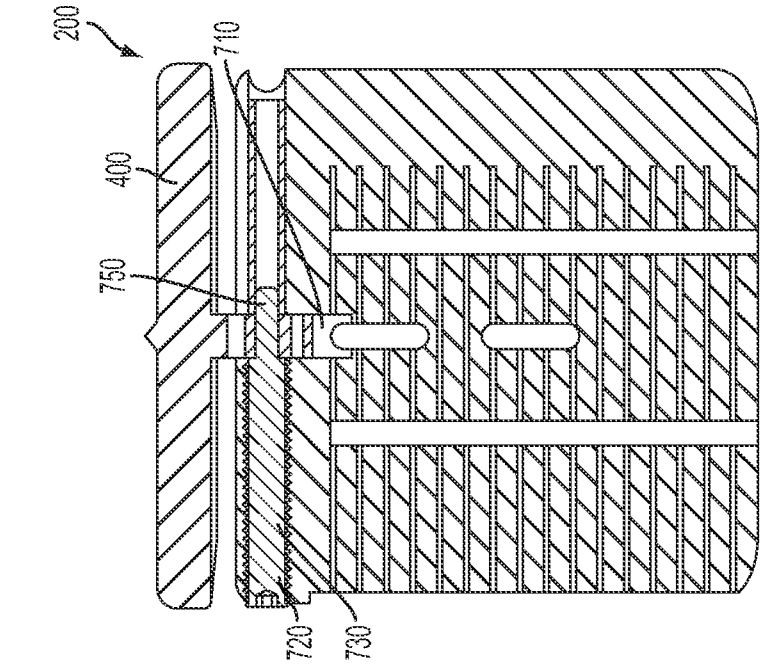

FIG. 37

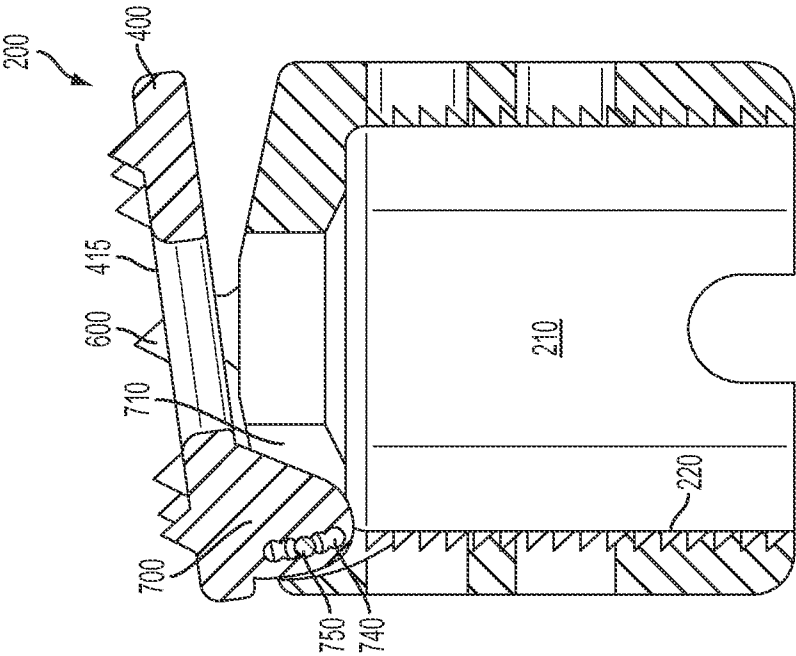

FIG. 38

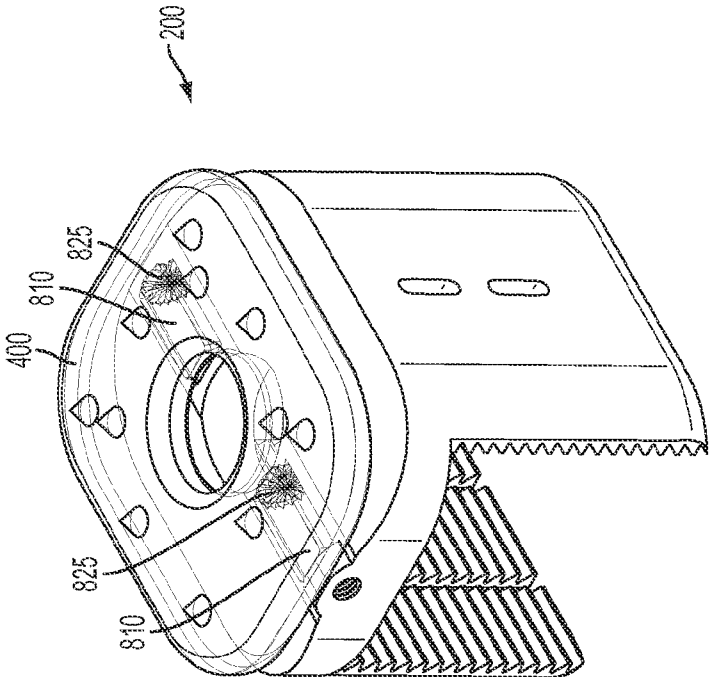

FIG. 39

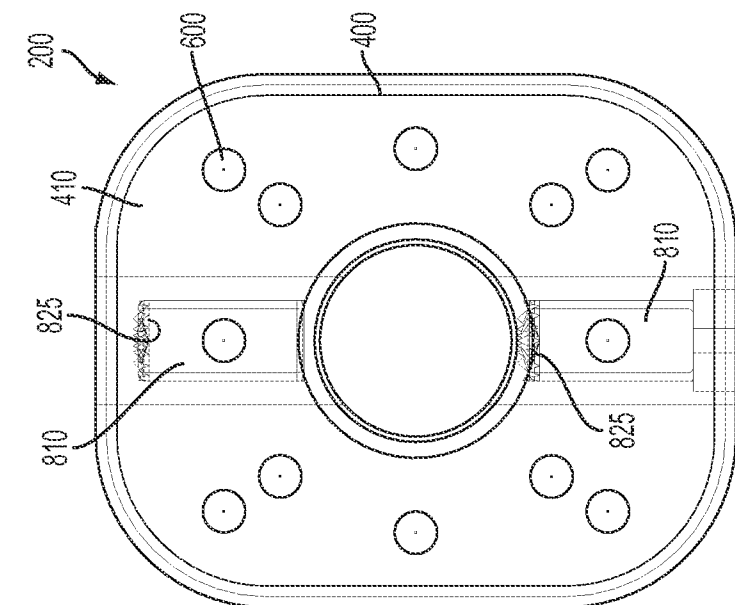

FIG. 40

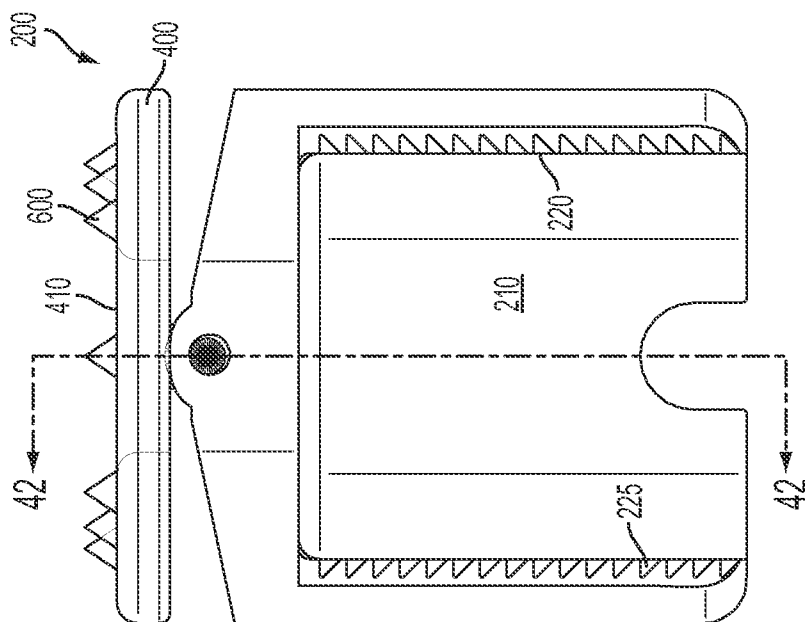

FIG. 41

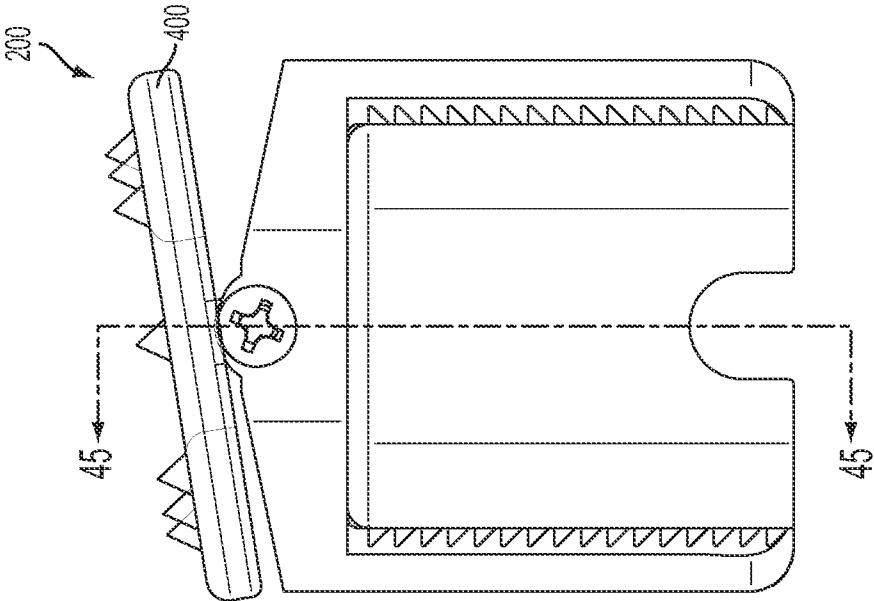

FIG. 43

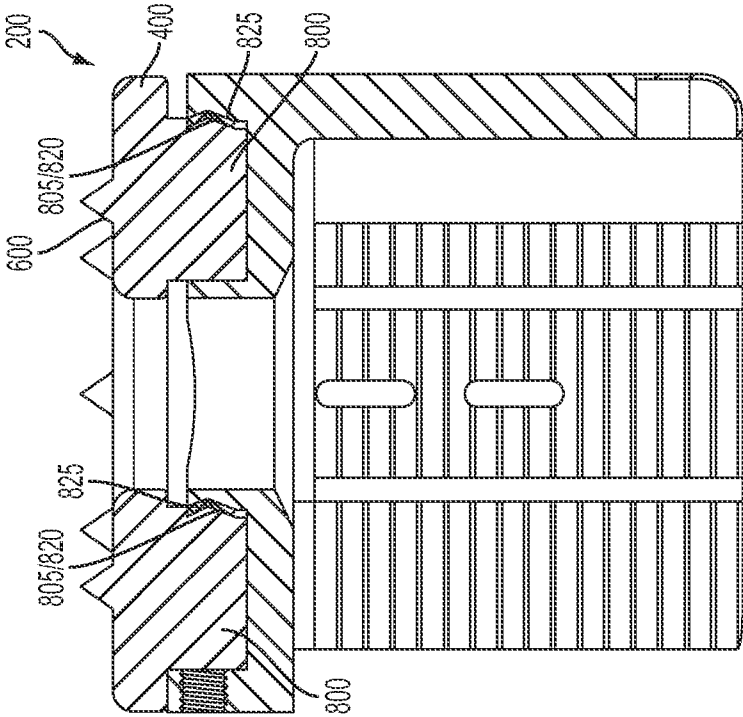

FIG. 42

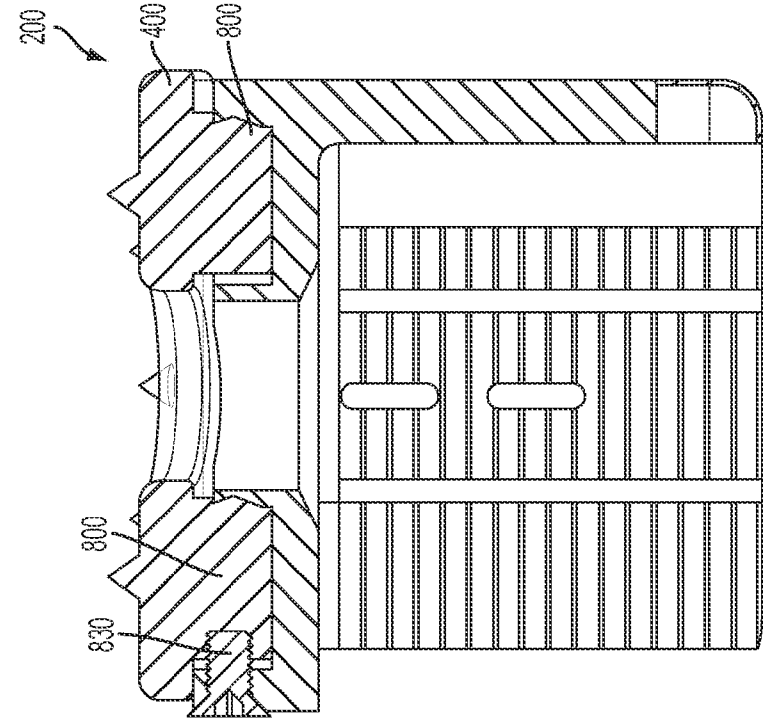

FIG. 45

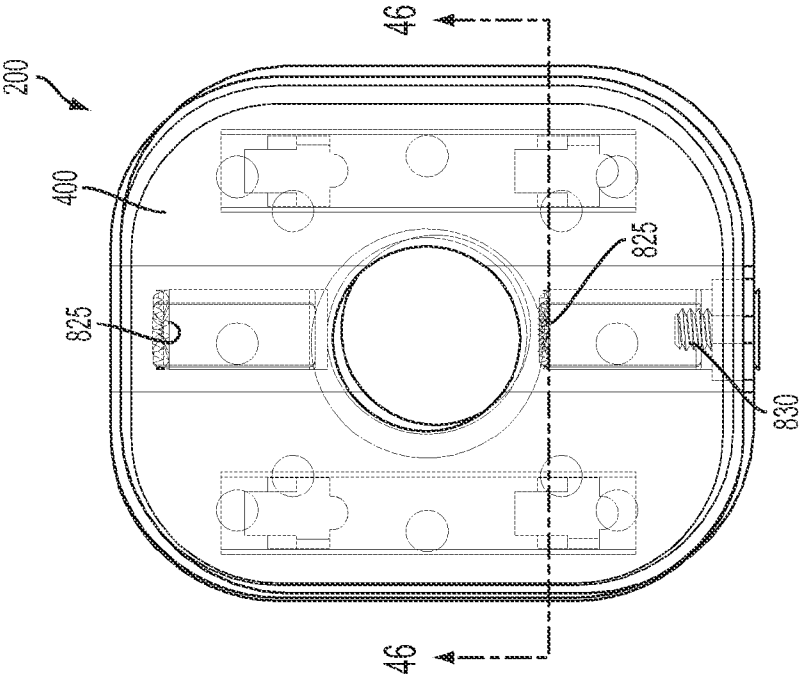

FIG. 44

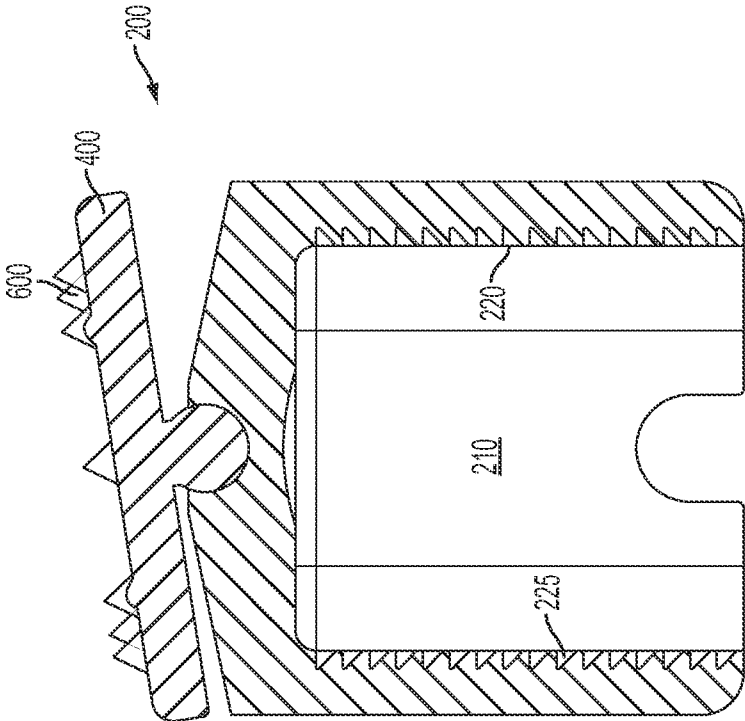

FIG. 46

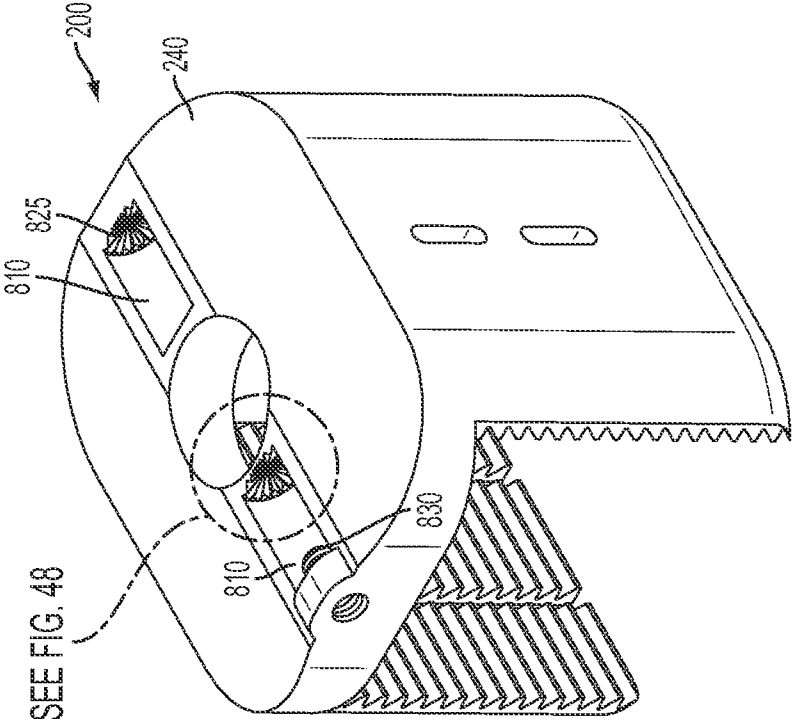

FIG. 47

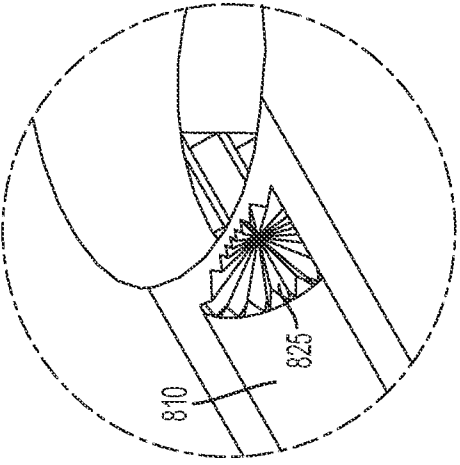

FIG. 48

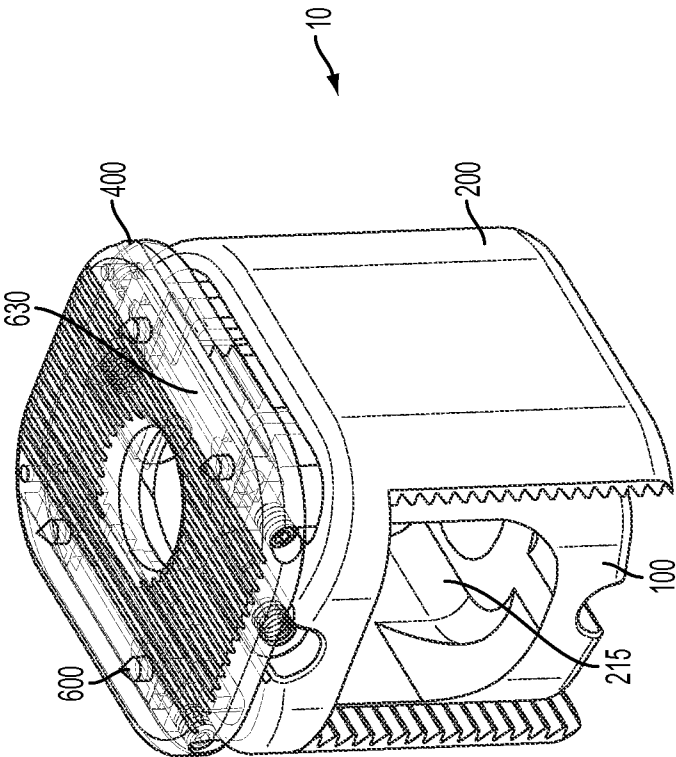

FIG. 49

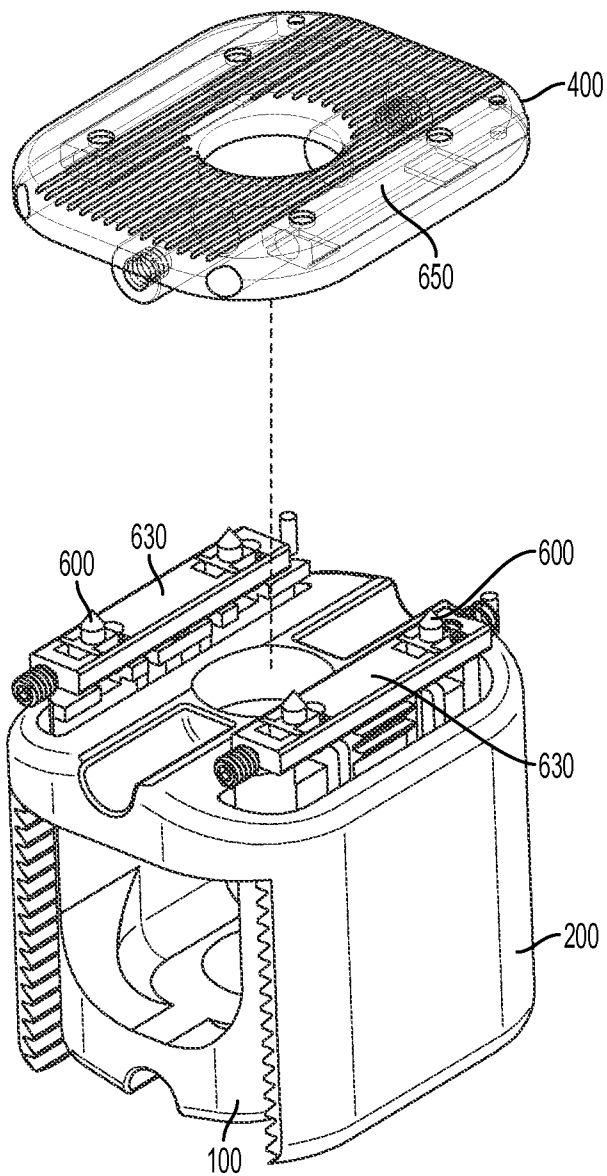

FIG. 50

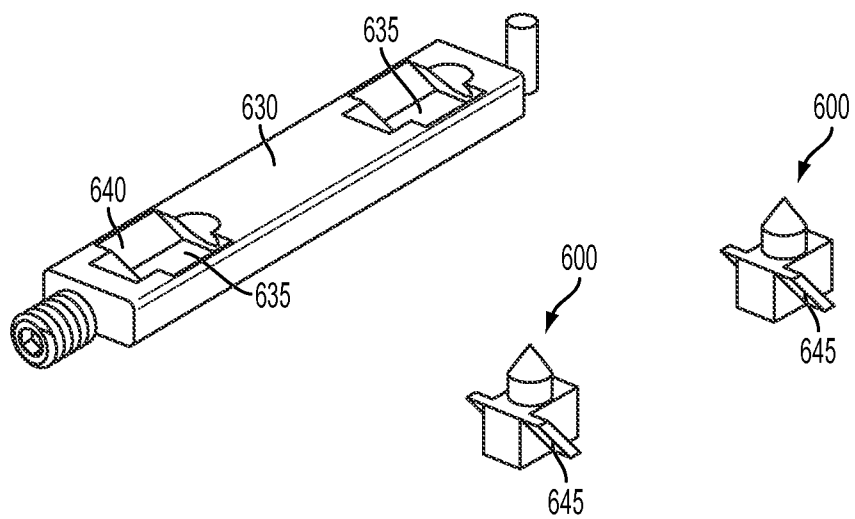

FIG. 50A

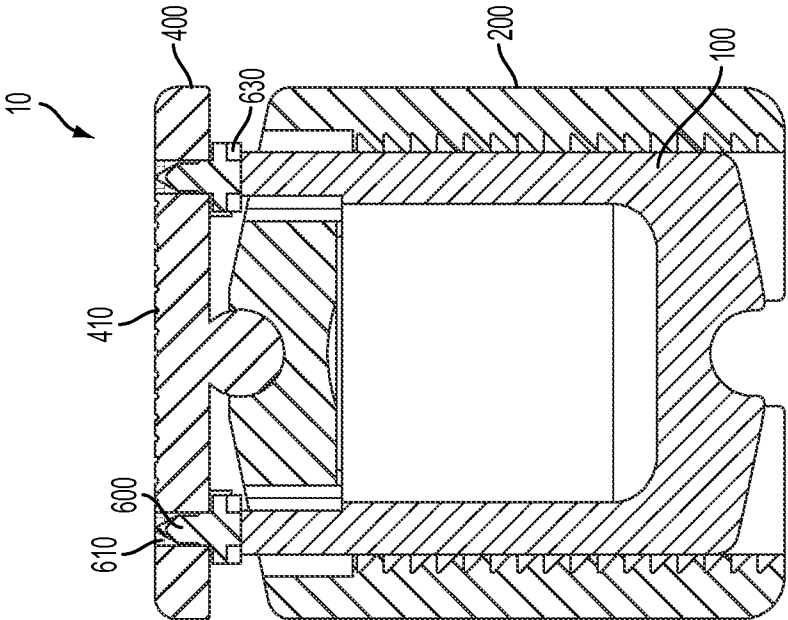

FIG. 51

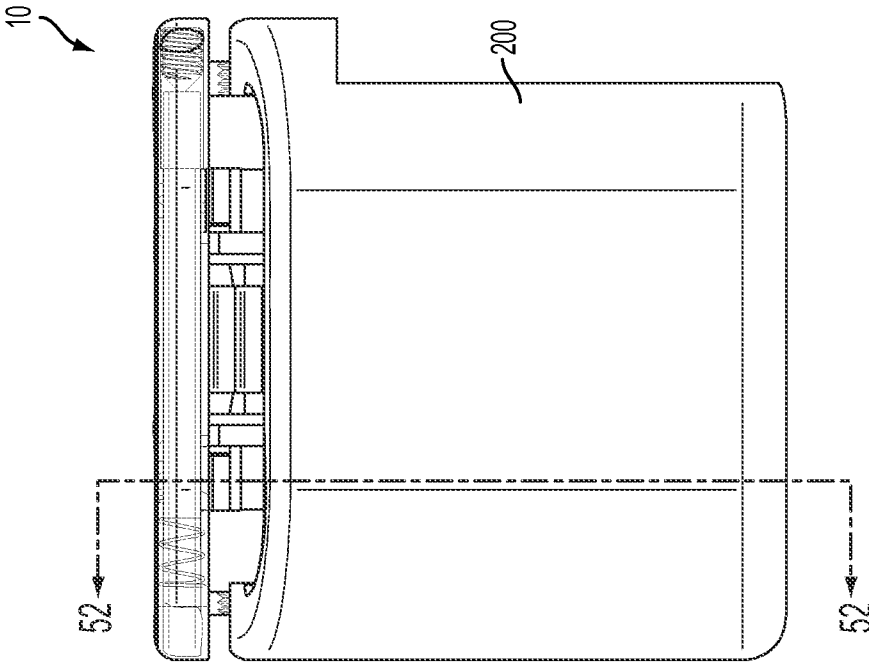

FIG. 52

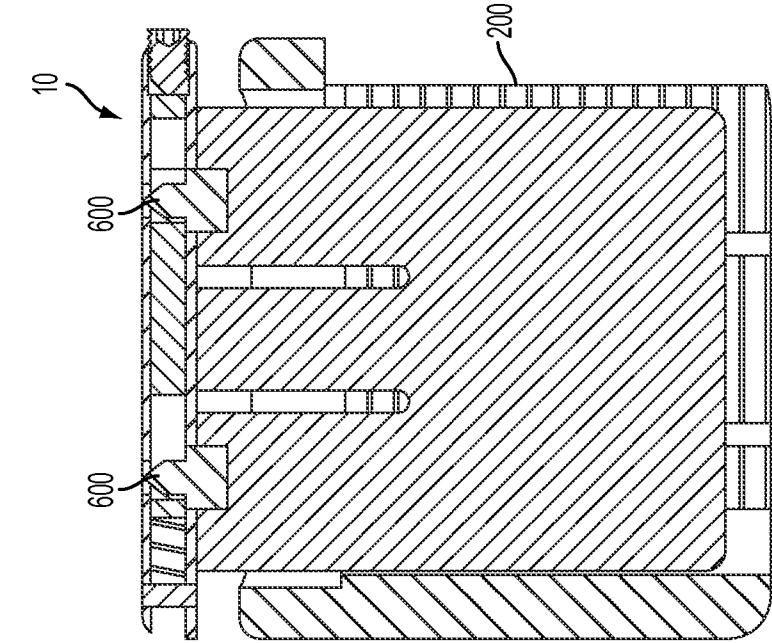

FIG. 53

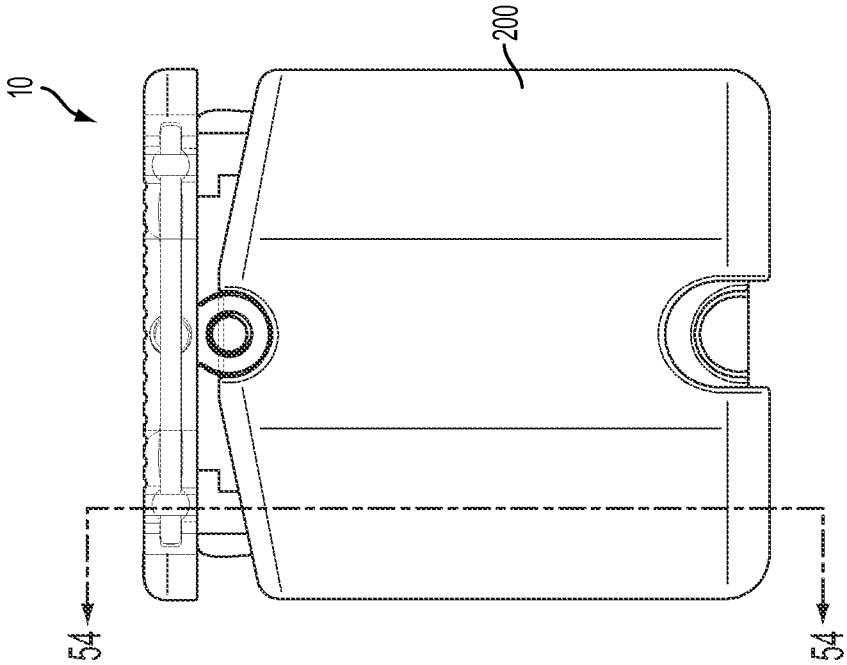

FIG. 54

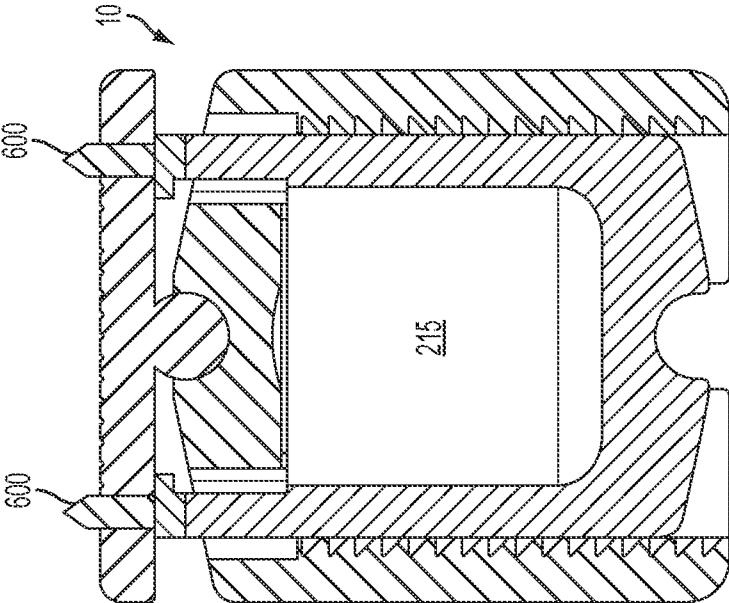

FIG. 55

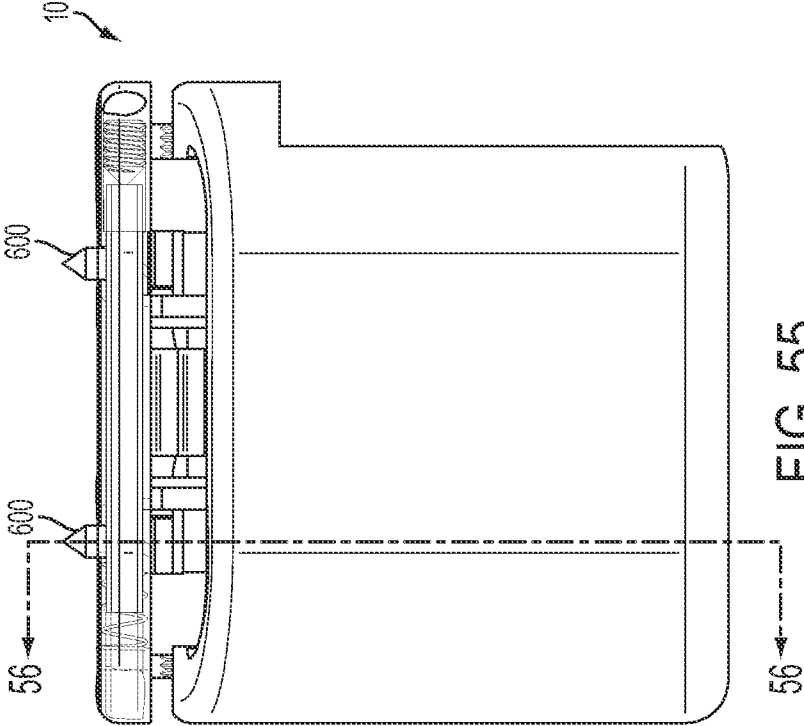

FIG. 56

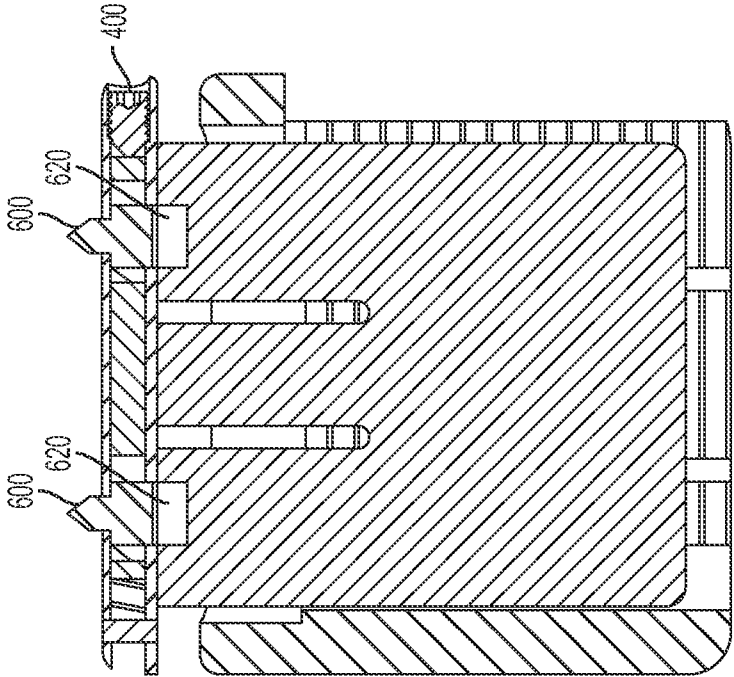

FIG. 58

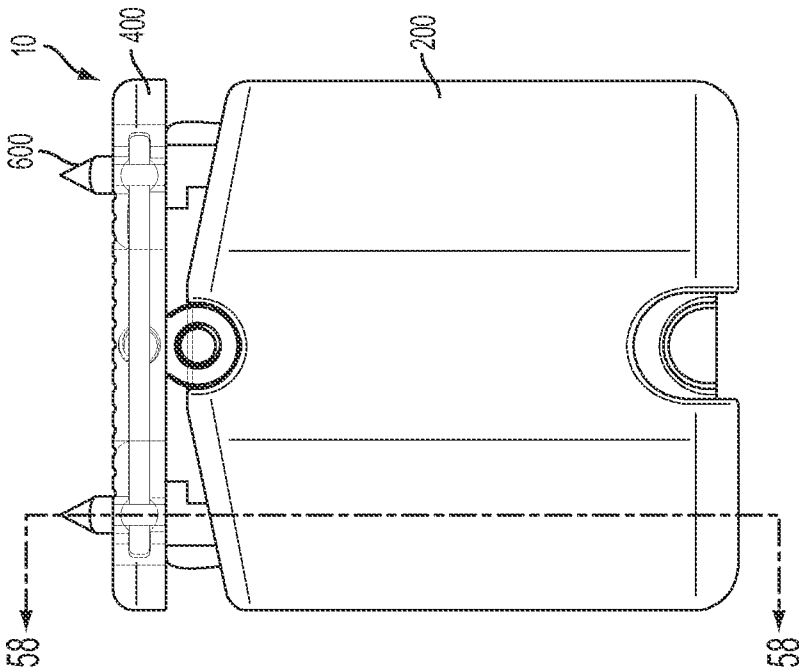

FIG. 57

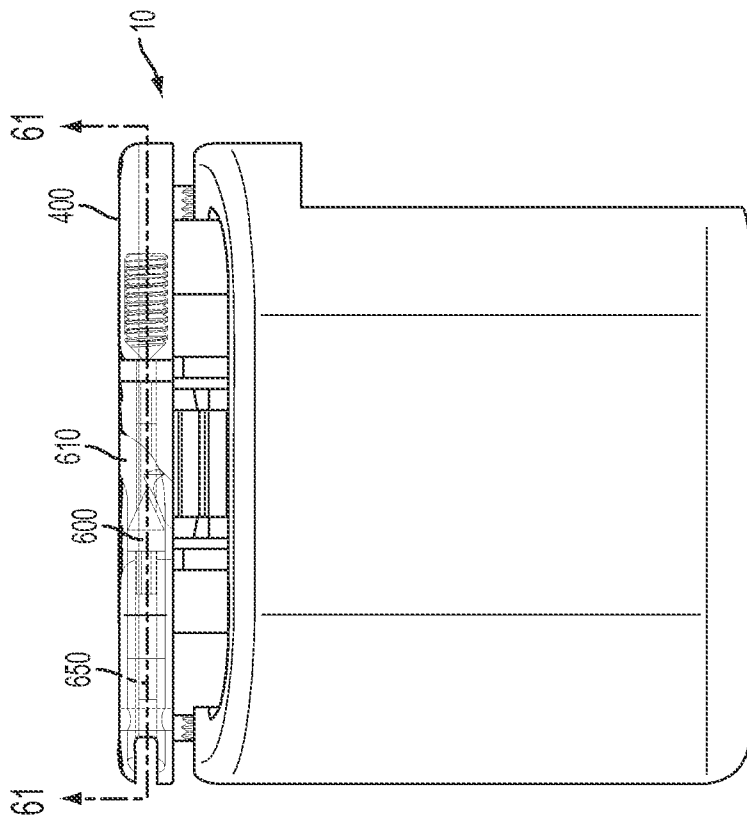

FIG. 59

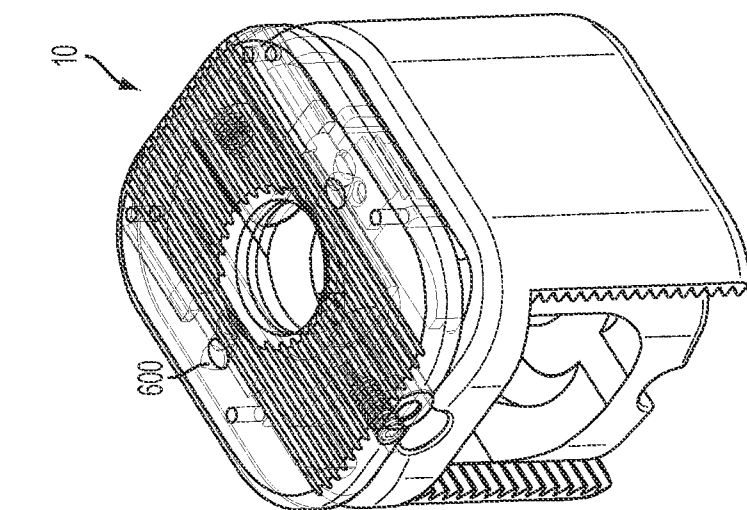

FIG. 60

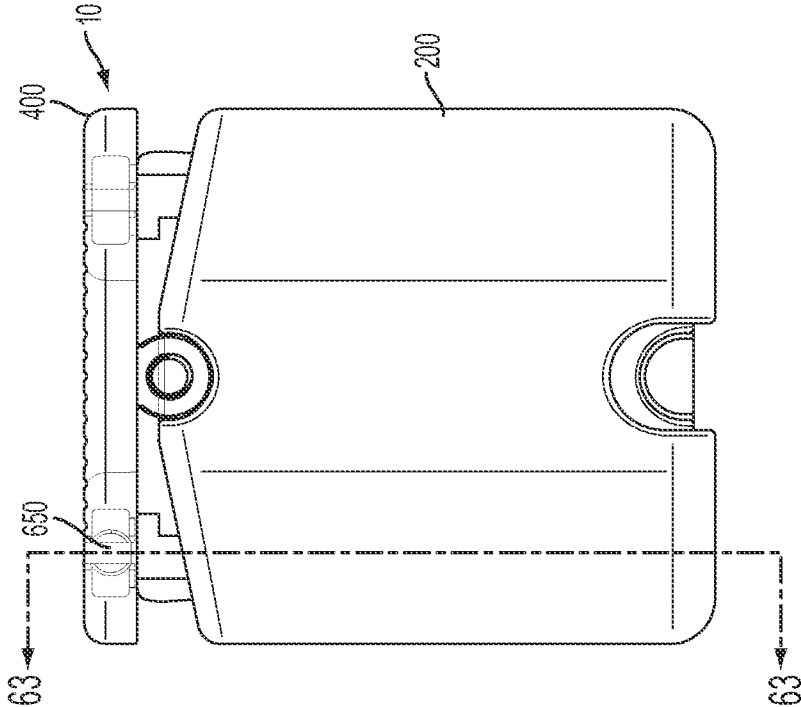

FIG. 62

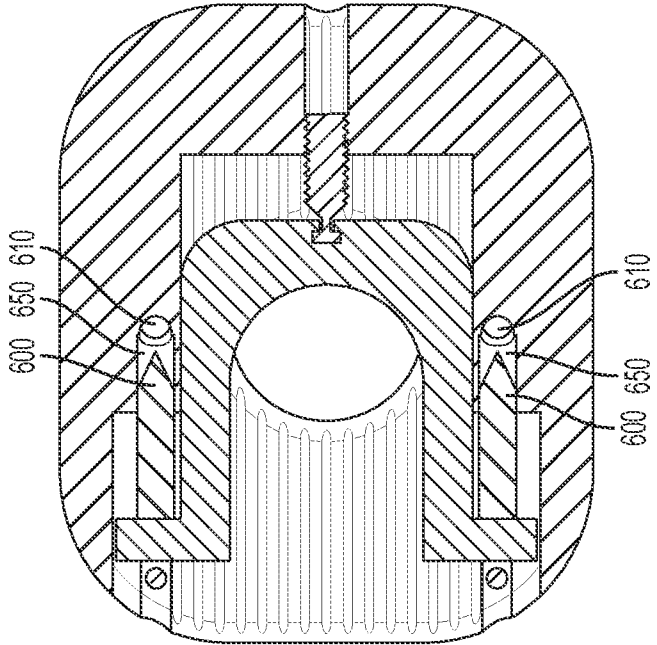

FIG. 61

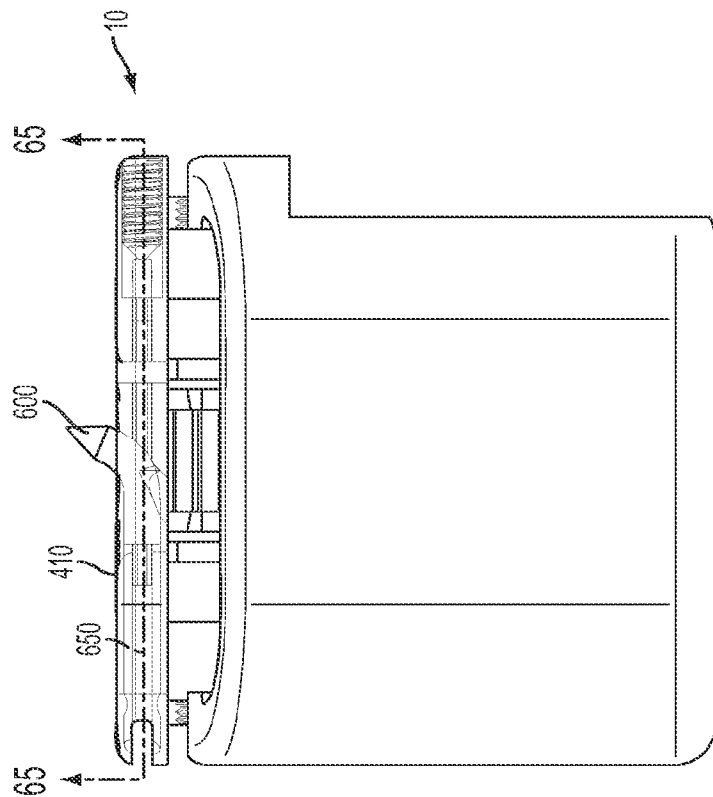

FIG. 64

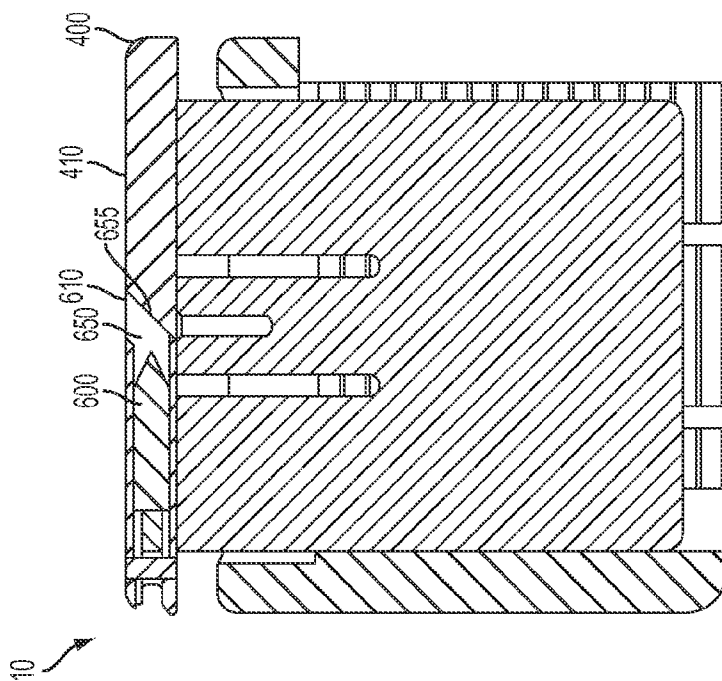

FIG. 63

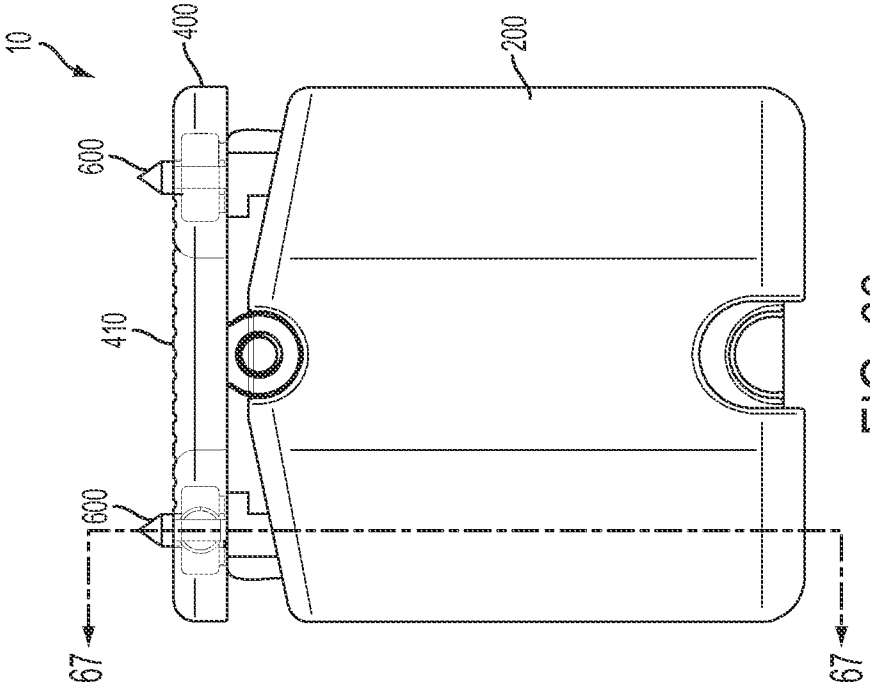

FIG. 66

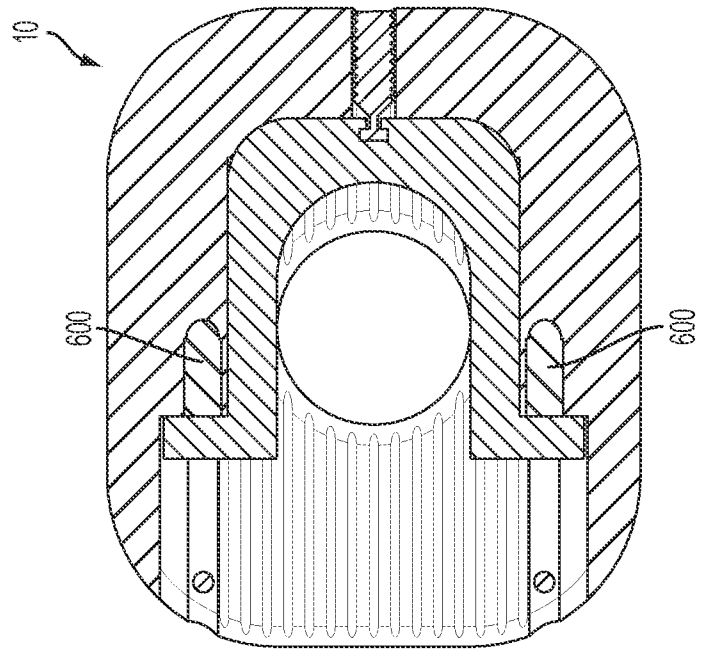

FIG. 65

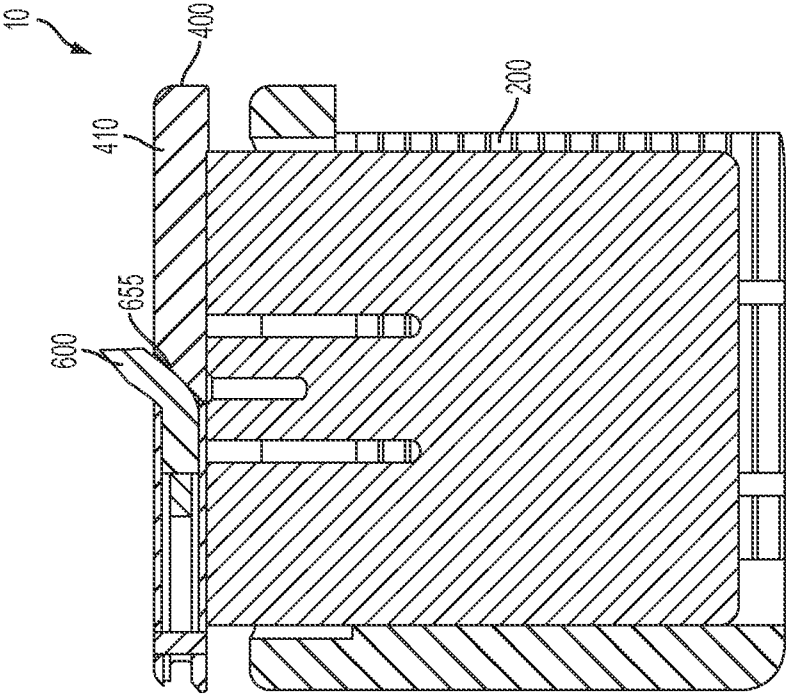

FIG. 67

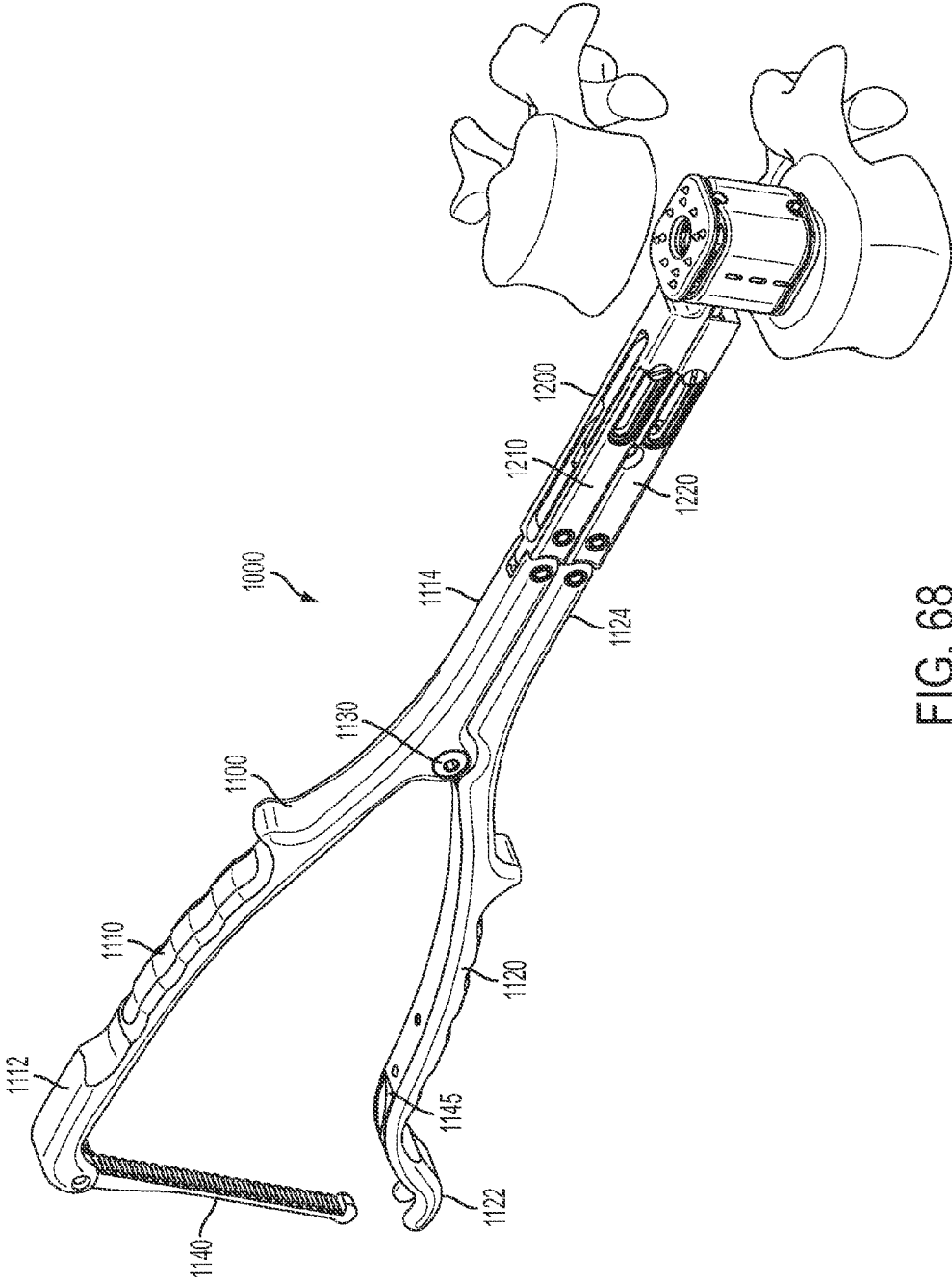

FIG. 68

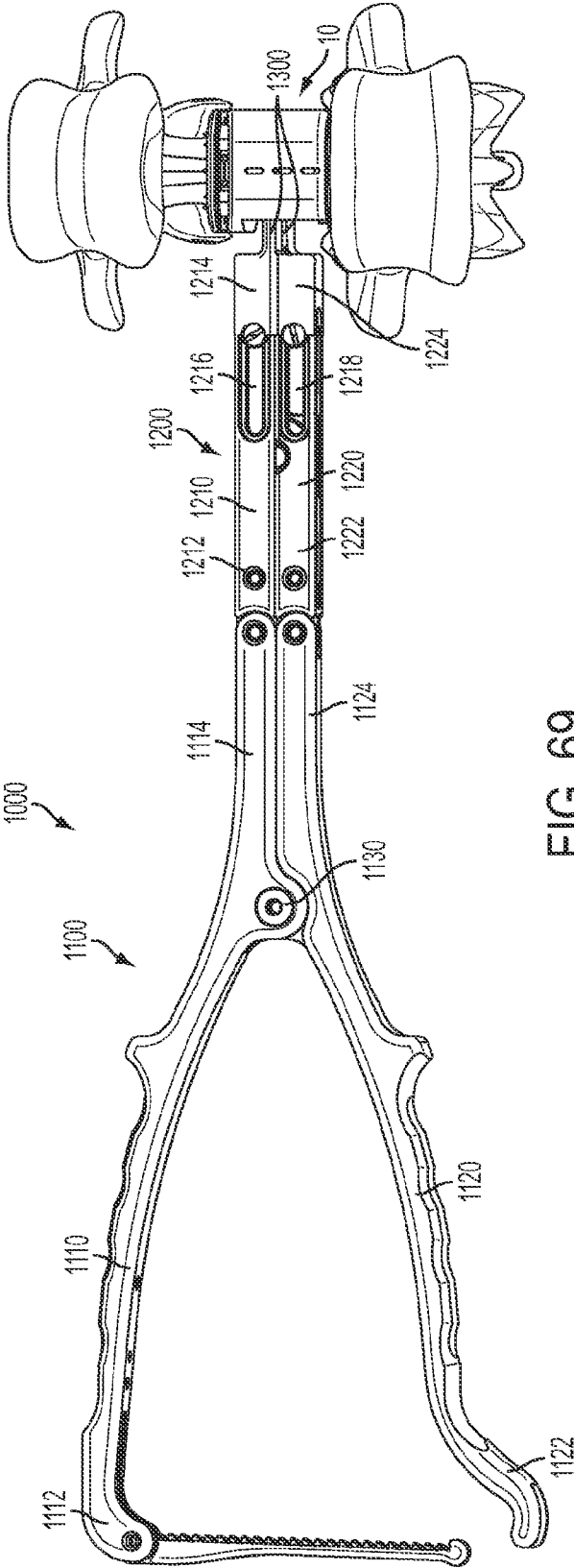

FIG. 69

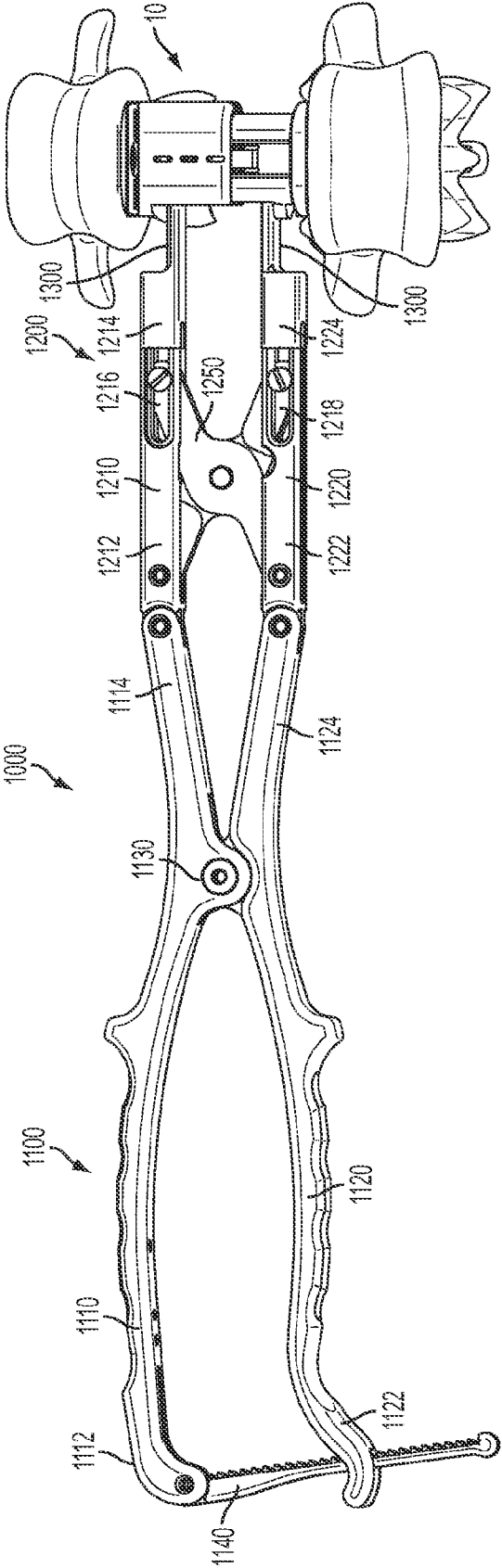

FIG. 70

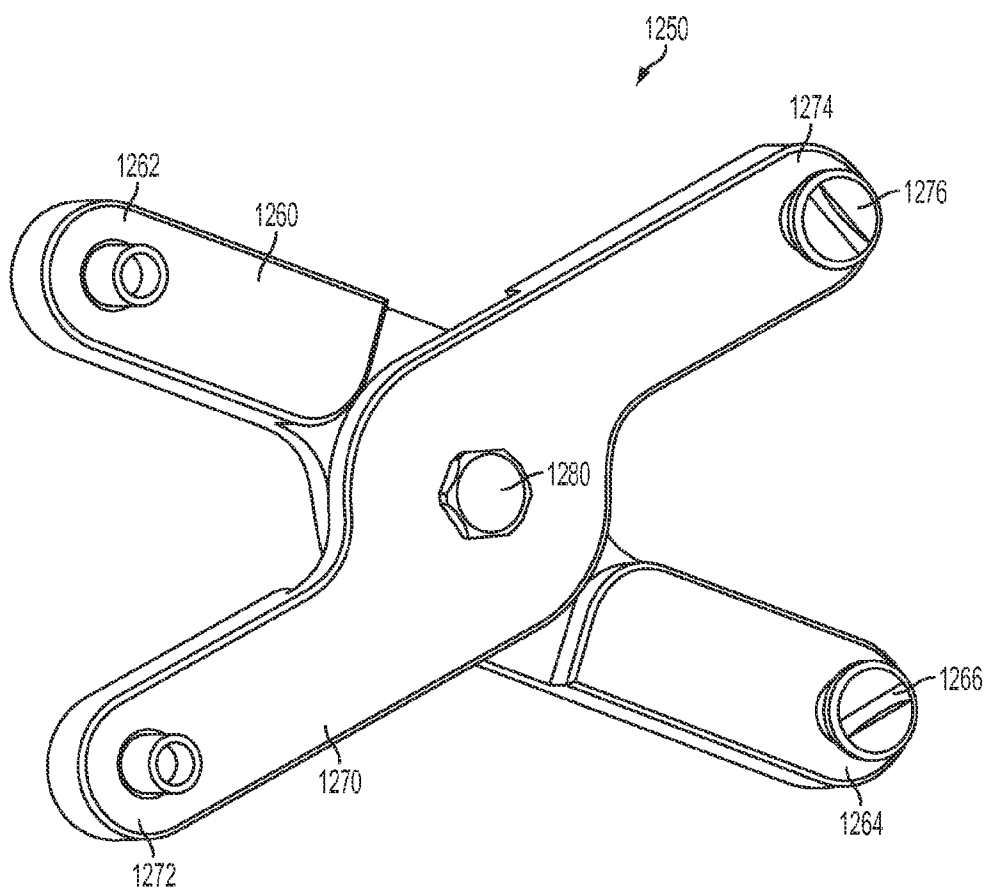

FIG. 71

EXPANDABLE VERTEBRAL BODY REPLACEMENT DEVICE, SYSTEM, AND METHODS

CONTINUITY

[0001] This application claims priority to and the benefit of U.S. Provisional Patent Application No. 61/802,360, filed on Mar. 15, 2013 and U.S. Utility application Ser. No. 14/216,513, filed on Mar. 17, 2014, the contents of which are incorporated herein in their entirety.

FIELD OF THE INVENTION

[0002] This invention relates generally to spinal surgery, and more particularly to devices and methods of stabilization of the spine following removal of a vertebral body, and replacing it with an expandable construct to stabilize the adjacent bones and provide a corridor between them for fusion purposes.

BACKGROUND OF THE INVENTION

[0003] Damage to a vertebral bone, often due to a traumatic fracture or due to invasion of the bone by tumor, at times requires removal of the vertebral body. This operation is known as a corpectomy. Following corpectomy, the resultant gap is generally filled in by a weight bearing support known as a Vertebral Body Replacement (VBR). This helps to restore and maintain the proper spacing between the adjacent bones, and often provides an area for placing graft material to span the adjacent bones in order to allow a fusion to take place.

[0004] VBRs may be sized to fit the gap, or be expandable over a range. The expandable VBRs currently available have significant limitations. These include the inability to adequately pack graft material in the channel within their post-expansion, a lack of a satisfactory match of the top and bottom of the implant to the adjacent bone surfaces, and expansion mechanisms that are complex, or take an inordinate amount of time to actuate. A need remains for an implant and surgical technique that will overcome these shortfalls.

SUMMARY

[0005] Presented herein is an expandable VBR device for use in spinal surgery following a vertebral corpectomy in the cervical, thoracic, or lumbar spine. The VBR device comprises an inner housing and an outer housing. The inner housing and outer housing can move in relation to one another in the longitudinal direction to increase or reduce the height of the VBR device. The VBR device can be expanded within a range from the first, unexpanded position, to a second fully expanded position or substantially any position therebetween.

[0006] A system is also presented, the system comprising a VBR device and a VBR expansion tool. In one exemplified aspect, the VBR expansion tool comprises an actuation member coupled to a leveling member. In use, compression of the handles of the actuation member from the first position to the second position, moves the leveling members from a position substantially adjacent one another to a separated position, moving the expandable VBR device from the unexpanded position to the expanded position.

[0007] A method of placing an expandable VBR into a corpectomy defect, and expanding the height of the device using a VBR expansion tool is also presented. The method comprises, accessing the desired motion segment, removing

the desired vertebral body, positioning the expandable VBR device in place of the removed vertebral body, expanding the expandable VBR device, and fixing the expandable VBR device in the expanded position. The method can also comprise fixing the lordotic angle of the upper and/or lower bone contact members. In another aspect, the method also comprises packing the graft cavity with bone growth promoting materials.

[0008] Related methods are also provided. Other apparatuses, methods, systems, features, and advantages of the expandable VBR device and the method of its use will be or become apparent to one with skill in the art upon examination of the following figures and detailed description. It is intended that all such additional apparatuses, methods, systems, features, and advantages be included within this description, be within the scope of the expandable VBR device and the method of its use, and be protected by the accompanying claims.

DESCRIPTION OF THE FIGURES

[0009] The accompanying drawings, which are incorporated in and constitute a part of this specification, illustrate certain aspects of the instant invention and together with the description, serve to explain, without limitation, the principles of the invention. Like reference characters used therein indicate like parts throughout the several drawings.

[0010] FIG. 1 is a partially exploded front perspective view of one aspect of a VBR device;

[0011] FIG. 2 is a partially exploded perspective view of the VBR device of FIG. 1;

[0012] FIG. 3 is a partially exploded side view of the VBR device of FIG. 1;

[0013] FIG. 4 is a partially exploded front view of the VBR device of FIG. 1;

[0014] FIG. 5 is a top plan view of the VBR device of FIG. 1;

[0015] FIG. 6 is a front view of another aspect of a VBR device in the unexpanded position;

[0016] FIG. 7 is a perspective view of the VBR device of FIG. 6 in an expanded position;

[0017] FIG. 8 is a top plan view of the VBR device of FIG. 6;

[0018] FIG. 9 is a cut away front view of the VBR device of FIG. 6, showing a ratchet mechanism for restraining the VBR from moving into the retracted position from the expanded position;

[0019] FIG. 10 is a partial perspective view of an interior wall of an inner sleeve of the VBR device of FIG. 6, showing the relationship of a tooth positioned on the interior wall of the outer sleeve with a recess defined in the exterior wall of the inner sleeve;

[0020] FIG. 11 is a cutaway view of the engagement of the inner and outer sleeve of the VBR device of FIG. 10;

[0021] FIG. 12 is a perspective view of the VBR device of FIG. 6, showing the VBR device positioned between two vertebrae;

[0022] FIG. 13 is a perspective view of the VBR device of FIG. 6, showing the VBR device with a VBR expansion tool;

[0023] FIG. 14 is a front view of one aspect of a VBR device showing an inner housing and an outer housing;

[0024] FIG. 15 is a perspective view of the VBR device of FIG. 14;

[0025] FIG. 16 is a cut away front view of the VBR device of FIG. 14, showing gear engaged with a toothed inner surface of the inner housing;

[0026] FIG. 17 is a top plan view of a retention member; and

[0027] FIG. 18 is a perspective view of the retention member of FIG. 17;

[0028] FIG. 19 is a front view of one aspect of a VBR device in the unexpanded position;

[0029] FIG. 20 is a front view of the VBR device of FIG. 19 in the expanded position, illustrating wedge members angling the bone contact members;

[0030] FIG. 21 is a front view of the VBR device of FIG. 19 in a partially expanded position, illustrating wedge members positioned to keep the bone contact members in a flat position;

[0031] FIG. 22 is a front view of the VBR device of FIG. 21 in the expanded position;

[0032] FIG. 23 is a perspective view of one aspect of a retention member for use with a VBR device;

[0033] FIG. 24 is a front elevational view of the retention member of FIG. 23;

[0034] FIG. 25 is a perspective view of a wedge member for use in a VBR device;

[0035] FIG. 26 is a perspective view of the VBR device of FIG. 19 in the unexpanded position, illustrating the VBR device between two vertebrae;

[0036] FIG. 27 is a front view of the VBR device of FIG. 19 in the expanded position, illustrating the VBR device between two vertebrae;

[0037] FIG. 28 is a perspective view of the VBR device of FIG. 19 in the expanded position, illustrating the VBR device between two vertebrae;

[0038] FIG. 29 is a perspective view of the VBR device of FIG. 19 in the expanded position, illustrating the VBR device between two vertebrae with a retention member in place;

[0039] FIG. 30 is a perspective view of the VBR device of FIG. 19, showing the VBR device being expanded by an expansion tool;

[0040] FIG. 31 is a perspective view of an outer housing for a VBR device;

[0041] FIG. 32 is a front view of the outer housing of FIG. 31, illustrating a blade and slot for locking the angular position of the bone contact member;

[0042] FIG. 33 as a top view of the outer housing of FIG. 31;

[0043] FIG. 34 is a cut-away front view of the outer housing of FIG. 31, cut along line 32-32;

[0044] FIG. 35 is a front view of the outer housing of FIG. 31, illustrating a set screw to lock the blade into position;

[0045] FIG. 36 is a top plan view of the outer housing of FIG. 31;

[0046] FIG. 37 is a front cut-away view of the outer housing of FIG. 31, cut along line 35-35 of FIG. 33;

[0047] FIG. 38 is a front cut-away view of the outer housing of FIG. 31, cut along line 38-38 of FIG. 36;

[0048] FIG. 39 is a partially transparent perspective view of an outer housing for a VBR device having an elongate pivot member to lock the angular position of the bone contact member;

[0049] FIG. 40 is a front view of the outer housing of FIG. 39;

[0050] FIG. 41 is a partially transparent top plan view of the outer housing of FIG. 39;

[0051] FIG. 42 is a cut-away side view of the outer housing of FIG. 39, cut along line 42-42 of FIG. 40;

[0052] FIG. 43 is a front view of the outer housing of FIG. 39, illustrating the upper bone contact member in the angled position;

[0053] FIG. 44 is a partially transparent top plan view of the outer housing of FIG. 39, showing a trough for receipt of a pivot member;

[0054] FIG. 45 is a cut-away side view of the outer housing of FIG. 39, cut along line 45-45 of FIG. 43;

[0055] FIG. 46 is a cut-away front view of the outer housing of FIG. 39, cut along line 46-46 of FIG. 44;

[0056] FIG. 47 is a perspective view of the outer housing of FIG. 39, illustrating the trough and engagement portion of the trough;

[0057] FIG. 48 is a section view of a section of the outer housing of FIG. 39 showing the section of FIG. 47;

[0058] FIG. 49 is a partially transparent perspective view of a VBR device, illustrating deployable spikes corresponding to an upper bone contact member;

[0059] FIG. 50 is a partially transparent cut-away perspective view of the VBR device of FIG. 49, illustrating ramp members associated with deployable spikes;

[0060] FIG. 50A is a perspective view of a ramp member and deployable spikes for use in the VBR device of FIG. 49;

[0061] FIG. 51 is a side view of the VBR device of FIG. 49, illustrating the spikes in a retracted position;

[0062] FIG. 52 is a cut-away front view of the VBR device of FIG. 49, cut along line 52-52 of FIG. 51;

[0063] FIG. 53 is a rear view of the VBR device of FIG. 49, illustrating the spikes in a retracted position;

[0064] FIG. 54 is a cut-away side view of the VBR device of FIG. 49, cut along line 54-54 of FIG. 53;

[0065] FIG. 55 is a side view of the VBR device of FIG. 49, illustrating the spikes in a deployed position;

[0066] FIG. 56 is a cut-away front view of the VBR device of FIG. 49, cut along line 56-56 of FIG. 55;

[0067] FIG. 57 is a rear view of the VBR device of FIG. 49, illustrating the spikes in a deployed position;

[0068] FIG. 58 is cut-away side view of the VBR device of FIG. 49, cut along line 58-58 of FIG. 57;

[0069] FIG. 59 is a partially transparent perspective view of a VBR device illustrating deployable flexible spikes;

[0070] FIG. 60 is a partially transparent side view of the VBR device of FIG. 59, illustrating the spikes in a retracted position;

[0071] FIG. 61 is a cut-away top plan view of the VBR device of FIG. 59, cut along line 61-61 of FIG. 60;

[0072] FIG. 62 is a rear view of the VBR device of FIG. 59, illustrating the spikes in a retracted position;

[0073] FIG. 63 is a cut-away side view of the VBR device of FIG. 59, cut along line 63-63 of FIG. 62;

[0074] FIG. 64 is a partially transparent side view of the VBR device of FIG. 59, illustrating the spikes in a deployed position;

[0075] FIG. 65 is a cut-away top plan view of the VBR device of FIG. 59, cut along line 65-65 of FIG. 64;

[0076] FIG. 66 is a rear view of the VBR device of FIG. 59, illustrating the spikes in a deployed position;

[0077] FIG. 67 is a cut-away side view of the VBR device of FIG. 59, cut along line 67-67 of FIG. 66;

[0078] FIG. 68 is a perspective view of one aspect of a VBR device and a VBR device expansion tool;

[0079] FIG. 69 is a side view of the VBR expansion tool of FIG. 68, illustrating the VBR expansion tool engaged with the VBR device in the retracted or unexpanded position;

[0080] FIG. 70 is a side view of the VBR expansion tool of FIG. 68, illustrating the VBR expansion tool engaged with the VBR device after expansion; and

[0081] FIG. 71 is a side view of a scissor member for a VBR expansion tool.

DESCRIPTION OF THE INVENTION

[0082] The present invention can be understood more readily by reference to the following detailed description, examples, and claims, and their previous and following description. Before the present system, devices, and/or methods are disclosed and described, it is to be understood that this invention is not limited to the specific systems, devices, and/or methods disclosed unless otherwise specified, as such can, of course, vary. It is also to be understood that the terminology used herein is for the purpose of describing particular aspects only and is not intended to be limiting.

[0083] The following description of the invention is provided as an enabling teaching of the invention in its best, currently known aspect. Those skilled in the relevant art will recognize that many changes can be made to the aspects described, while still obtaining the beneficial results of the present invention. It will also be apparent that some of the desired benefits of the present invention can be obtained by selecting some of the features of the present invention without utilizing other features. Accordingly, those who work in the art will recognize that many modifications and adaptations to the present invention are possible and can even be desirable in certain circumstances and are a part of the present invention. Thus, the following description is provided as illustrative of the principles of the present invention and not in limitation thereof.

[0084] As used herein, the singular forms “a,” “an” and “the” include plural referents unless the context clearly dictates otherwise. Thus, for example, reference to a “plate” includes aspects having two or more plates unless the context clearly indicates otherwise.

[0085] Ranges can be expressed herein as from “about” one particular value, and/or to “about” another particular value. When such a range is expressed, another aspect includes from the one particular value and/or to the other particular value. Similarly, when values are expressed as approximations, by use of the antecedent “about,” it will be understood that the particular value forms another aspect. It will be further understood that the endpoints of each of the ranges are significant both in relation to the other endpoint, and independently of the other endpoint.

[0086] As used herein, the terms “optional” or “optionally” mean that the subsequently described event or circumstance may or may not occur, and that the description includes instances where said event or circumstance occurs and instances where it does not.

[0087] Terms used herein, such as “exemplary” or “exemplified,” are not meant to show preference, but rather to explain that the aspect discussed thereafter is merely one example of the aspect presented.

[0088] Additionally, as used herein, relative terms, such as “substantially,” “generally,” “approximately,” and the like, are utilized herein to represent an inherent degree of uncertainty that may be attributed to any quantitative comparison, value, measurement, or other representation. These terms are

also utilized herein to represent the degree by which a quantitative representation may vary from a stated reference without resulting in a change in the basic function of the subject matter at issue.

[0089] In one aspect, presented herein is an expandable VBR device 10 for use in spinal surgery following a vertebral corpectomy in the cervical, thoracic, or lumbar spine. The VBR device comprises an inner housing 100 and an outer housing 200. The inner housing 100 and outer housing 200 can move in relation to one another in the longitudinal direction to increase or reduce the height of the VBR device 10. In one exemplified aspect, the outer housing defines in interior cavity 210 within which the inner housing can nest in the unexpanded position. In another aspect, the inner housing 100 and outer housing 200, together, define a graft cavity 215 for the placement of bone graft material, to include, but not limited to, allograft, bone substitute, or other biocompatible bone growth promoting materials.

[0090] The VBR device can be expanded within a range from the first, unexpanded position, to a second fully expanded position or substantially any position therebetween. In an exemplified aspect, an interior surface 220 of the outer housing 200 comprises a toothed surface 225. A toothed surface can be positive, such as protrusions, or negative, such as recesses. In one aspect, the exterior surface 110 of the inner housing 100 comprises a toothed surface 125, as well. Each tooth can comprise a cam 130, 230 surface and a flat surface 135, 235. In one aspect, the toothed surfaces are complementarily opposite, meaning that in the expanding direction, the cam surface 230 of a tooth 225 on the outer housing 200 mates with the cam surface 130 of a tooth 125 on the inner housing 100 and, in the retracting direction, the flat surface 235 of a tooth 230 on the outer housing 200 engages the flat surface 135 of a tooth 125 on the inner housing 100. This relationship permits the two housings to move in the expanding direction in a ratcheting manner, but prevents the two housings to move in the retracting direction.

[0091] In another exemplified aspect, each tooth 125, 225 can comprise two cam surfaces 130, 230, without a flat surface. Additionally, the VBR device can comprise a retention member 300 configured to engage at least a portion of the toothed surface of the inner housing to prevent longitudinal up and down movement of the outer housing with respect to the inner housing. In one aspect, the retention member can be a u-shaped member sized to horizontally slide around at least at least portions the exterior surface 110 of the inner housing 100.

[0092] In still another exemplified aspect, the inner housing may define a window 160 having a toothed edge portion 165. In this aspect, a gear 260 can be positioned on the outer housing 200 configured to engage the toothed edge portion 165 of the window 160 of the inner housing 100. In one aspect, the exterior surface 110 of the inner housing may comprise a toothed surface 125. The VBR device can also comprise a retention member 300 configured to engage the exterior surface of the inner housing to restrict movement of the inner housing with respect to the outer housing. The retention member can be a c-ring configured to at least partially wrap around the inner housing and engage at least one of the teeth on the external surface of the inner housing.

[0093] The retention member 300 can have, for example, edge portion 310 that are cammed and complimentary to the toothed surfaces 225 of the interior surface 220 of the outer housing 200. However, since the toothed surfaces are gener-

ally sloped, the edge portion of the retention member need not be angled, sloped, or cammed. It is also contemplated that the edge portion 310 of the retention member have a top surface 315 that is substantially flat in order to retain the flat portion 235 of the toothed surfaces 225 of the interior surface 220 of the outer housing 200. In still another aspect, the retention member can be removably attached to a portion of the inner housing. As illustrated in FIG. 20, the top portion 140 of the inner housing 100 can comprise a tongue 145 and the edge portion 310 of the retention member 300 can comprise a corresponding groove 320 to enable the retention member to slide into position at a top portion of the inner housing. In this aspect, when the retention member is positioned in engagement with the inner housing, the outer housing is prevented from retracting downward toward the unexpanded position, while still being able to ratchet in the upward direction toward the expanded position. When the retention member is moved out of engagement with the inner housing, the outer housing can therefore move in either direction substantially unimpeded.

[0094] In an exemplified aspect, the VBR device comprises an upper bone contact member 400 and a lower bone contact member 450. The upper bone contact member 400 has an upper bone contact surface 410 configured for contact with a lower portion of a first vertebra. The lower bone contact member 450 has a lower bone contact surface 460 configured for contact with an upper portion of a second vertebra. One or both of the upper and lower bone contact members can be substantially planar. In one aspect, the upper bone contact member can be pivotally connected to a portion of the top portion 240 of the outer housing. The pivot point 415 can, for example, be in substantially the center of the of the upper bone contact member, enable the upper bone contact member to angulate in either the anterior or posterior direction. The function permits the VBR device to adapt to the anatomy of the patient. As can be appreciated, the lower bone contact member 450 can be pivotally connected to a portion of the bottom portion 150 of the inner housing 100. The pivot point 465 can, for example, be in substantially the center of the of the lower bone contact member 450, enabling the lower bone contact member to angulate in either the anterior or posterior direction.

[0095] In still another aspect, the VBR device comprises an inner and outer sleeve 500, 550, wherein the outer and inner sleeves are configured to move longitudinally with respect to one another from the retracted position to the expanded position. The inner and outer sleeve define an interior cavity 555. In an exemplified aspect, an interior surface 560 of the outer sleeve 550 comprises a toothed surface 565. In one aspect, the exterior surface 510 of the inner sleeve 500 comprises a toothed surface 515, as well. Each tooth can comprise a cam surface 516, 566 and a flat surface 517, 567. In one aspect, the toothed surfaces are complementarily opposite, meaning that in the expanding direction, the cam surface of a tooth on the outer sleeve mates with the cam surface of a tooth on the inner sleeve and, in the retracting direction, the flat surface of a tooth on the outer sleeve engages the flat surface of a tooth on the inner sleeve. This relationship permits the two sleeves to move in the expanding direction in a ratcheting manner, but prevents the two sleeves to move in the retracting direction. As one skilled in the art can appreciate, in lieu of complimentary toothed surfaces, the inner and outer sleeves can comprise one toothed surface and define a complimentary recess

520 on the other surface, where the recess 520 has a flat interior edge 522 that compliments the flat surface 567 of the tooth of the other surface.

[0096] In this aspect, the upper bone contact member can be hingedly attached to a top portion 580 of the outer sleeve and the lower bone contact member can be hingedly attached to a lower portion 530 of the inner sleeve. This configuration permits angulation of the bone contact members to complement the adjacent vertebral bodies. In an exemplified aspect, the inner and outer sleeves nest within one another and define a pillar window 570. In this aspect, the VBR device comprise a pillar 20 configured to fit within the interior cavity 555 to be placed into the interior cavity via the pillar window 570. In an exemplified aspect, a top portion 21 of the pillar is angled and the bottom portion of the pillar 22 is also angled. The top portion 21 of the pillar engages a portion of the upper bone contact member 400 and the angle of the top portion of the pillar places the upper bone contact member to the desired angle for lordosis. Similarly, the bottom portion 22 of the pillar engages a portion of the lower bone contact member 450 and the angle of the lower portion of pillar places the lower bone contact member to the desired angle for lordosis. The pillar, of course, substantially prevents the VBR device from moving from the expanded position to the retracted position.

[0097] One or both of the upper and lower bone contact members 400, 450 can comprise spikes 600 or protrusions to facilitate engagement with the respective vertebral bone. The spikes can be integral with the respective upper or lower bone contact member or they can be deployed after insertion into the disc space. In one exemplified aspect, as illustrated in FIG. 42, the respective bone contact member can define at least one spike aperture 610 in communication with a spike cavity 620. A spike can be sized to fit substantially completely therein the spike cavity 620. In one aspect, a ramp member 630 can be positioned within a channel 650 defined in the bone contact member defining an orifice 635 that is partially coaxial with the spike cavity 620. The edges of the orifice and the spike comprise complimentary cam 640 and follower 645 surfaces such that, when the ramp member 630 is moved in a first direction, the spike rides along the ramp member, raising it to extend the distal portion of the spike above the bone contact surface of the bone contact member. Of course, it is contemplated that the spike can comprise a plurality of spikes and the spike cavity can comprise a plurality of spike cavities. Additionally, the ramp member can comprise a plurality of ramp members. Each ramp member may define a plurality of orifices, each corresponding to a spike and spike cavity, as illustrated in FIG. 42.

[0098] In another aspect, the spikes 600 can comprise a flexible material, such as Nitinol or spring steel. In this aspect, the spikes can be initially embedded within a channel 650 in the respective bone contact member in a plane that is substantially parallel to the respective bone contact surface. Each of the spike apertures 610 can be associated with a ramped or angled portion 655 of the bone contact member such that, when the flexible spike is moved toward the spike aperture, the spike will angle upward and through the spike aperture.

[0099] In one exemplified aspect, one or both of the bone contact members can be locked in angular position, substantially restraining the respective bone contact member from pivoting with respect to the respective inner or outer housing. In one aspect, as shown in FIG. 25, the respective bone contact member can comprise a blade 700 positioned on a

second surface **420, 470** of the bone contact member **400, 450**, opposite the bone contact surface, and substantially perpendicular thereto the second surface. In this aspect, the top of the outer housing, or the bottom of the inner housing, depending on which bone contact member is being discussed, can define a blade slot **710** configured for receipt of the blade **700**. The respective housing can also define a threaded aperture **720** configured for receipt of a set screw **730** adapted to fit within the threaded aperture **720** and engage a portion of the blade **700** to substantially fix its position with respect to the respective housing. As shown in the figures, the blade can define a plurality of blade apertures into which the end of the set screw can engage to assist in holding the respective bone contact member in angular position.

[0100] In another aspect, as shown in FIG. **32a**, the respective bone contact member can comprise at least one elongate pivot member **800** configured to fit within a respective trough **810** defined in the top surface **240** of the outer housing (or the bottom surface of the inner housing). The elongate pivot member **800** can comprise a substantially cylindrical shape, but other shapes are contemplated. In one aspect at least a distal end **805** of the elongate pivot member can define a raised and/or depressed pattern **820**. In this aspect, a portion of the trough **810** defines a complementarily patterned raised and/or depressed section **825**. In one aspect, the pattern is a starburst, as shown in FIG. **32a**, but other complimentary patterns are contemplated. In this aspect, urging the distal end of the pivot member into engagement with the patterned portion of the trough fixes the angle of the bone contact member with respect to the respective housing. For example, a set screw **830** may be used, as shown in FIG. **37**, to urge the pivot member into engagement with the patterned portion of the trough.

[0101] In still another aspect, the respective bone contact member can be locking into angular position by insertion of a wedge member **900** in the space between the bone contact member and the respective housing. FIG. **20** shows a wedge member between the upper bone contact member and the outer housing and another wedge member between the lower bone contact member and the inner housing. The wedge members can be configured in various ways to achieve the desired angle. In one aspect, the wedge member can be fixed to the VBR with a fixation device, such as a screw.

[0102] A system is presented, comprising a VBR device and a VBR expansion tool **1000**. In one exemplified aspect, the VBR expansion tool **1000** comprises an actuation member **1100** coupled to a leveling member **1200**. The actuation member comprises a first handle **1110** hingedly coupled to an opposed second handle **1120**. The first handle comprises a proximal end **1112** configured to be held by a person's hand and a distal end **1114**, with a hinge point **1130** therebetween. The second handle **1120** also comprises a proximal end **1122** configured to be held by a person's hand and a distal end **1124**, with the hinge point therebetween **1130**. The actuation member is configured to move from a first position where the proximal ends of the handles are at their most separated position and where the distal ends of the handles are at substantially their closest position, to a second position where the proximal ends of the handles are compressed toward one another and where the distal ends of the handles are separated. The VBR expansion tool can also comprise a compression retention member **1140** hingedly connected to a proximal end of one of the first or second handles configured to engage a catch mechanism **1145** positioned on the other handle. The

compression retention member, when engaged with the catch mechanism, substantially maintains pressure on the first and second handles.

[0103] Continuing with the VBR expansion tool, the leveling member **1200** comprises an upper leveling member **1210** and a lower leveling member **1220**, the two leveling members are separated by and connected by a scissor member **1250**. The scissor member comprises a first scissor arm **1260** and a second scissor arm **1270**. The scissor arms **1260, 1270** are pinned substantially in their middle section **1280**, similar to common scissors. The proximal end **1262** of the first scissor arm **1260** is pinned to a proximal end **1212** of the upper leveling member **1210** and the distal end **1264** of the first scissor arm comprises a first pin **1266** configured to engage, in sliding relation, an elongate slot **1218** defined in the lower leveling member. Similarly, the proximal end **1272** of the second scissor arm **1270** is pinned to a proximal end **1222** of the lower leveling member **1220** and the distal end **1274** of the second scissor arm comprises a second pin **1276** configured to engage, in sliding relation, and elongate slot **1216** defined in the upper leveling member. In this fashion, as the proximal end of the upper leveling member is separated from the proximal end of the lower leveling member, the distal end of the upper leveling member is also raised and equally separated from the distal end of the lower leveling member. As can be appreciated, the relation of the arms to the leveling members can be reversed with similar results.

[0104] As illustrated in FIG. **69**, the distal end of the first handle **1114** can be hingedly connected to the proximal end **1214** of the upper leveling member and the distal end **1124** of the second handle can be hingedly connected to the proximal end **1222** of the lower leveling member. Additionally the distal end of the upper and lower leveling members can comprise forks **1300** to engage portions of the expandable VBR device. In use, compression of the handles of the actuation member from the first position to the second position, moves the leveling members from a position substantially adjacent one another to a separated position. By doing so, when the forks are engaged with portions of the inner and outer housings, the expandable VBR device moves from the unexpanded position to the expanded position.

[0105] A method of placing an expandable VBR into a corpectomy defect, and expanding the height of the device using a VBR expansion tool is presented. The method comprises, accessing the desired motion segment, removing the desired vertebral body, positioning the expandable VBR device in place of the removed vertebral body, expanding the expandable VBR device, and fixing the expandable VBR device in the expanded position. The method can also comprise fixing the lordotic angle of the upper and/or lower bone contact members. In another aspect, the method also comprises packing the graft cavity with bone growth promoting materials.

[0106] Although several aspects of the invention have been disclosed in the foregoing specification, it is understood by those skilled in the art that many modifications and other aspects of the invention will come to mind to which the invention pertains, having the benefit of the teaching presented in the foregoing description and associated drawings. It is thus understood that the invention is not limited to the specific aspects disclosed hereinabove, and that many modifications and other aspects are intended to be included within the scope of the appended claims. Moreover, although specific terms are employed herein, as well as in the claims that

follow, they are used only in a generic and descriptive sense, and not for the purposes of limiting the described invention.

What is claimed is:

1. A vertebral body replacement device comprising:
 - an outer housing defining an interior cavity and having an interior toothed surface;
 - an inner housing nesting within at least a portion of the interior cavity of the outer housing, the inner housing moveable along a longitudinal direction to increase a height of the vertebral body replacement device;
 - a retention member removably engageable with a portion of the inner housing, the retention member defining at least one outer edge that is cammed and complimentary to the interior toothed surface of the outer housing, wherein the retention member, when positioned in engagement with the inner housing, permits expansion of the vertebral body replacement device while preventing contraction of the vertebral body replacement device;
 - an upper bone contact member having an upper bone contact surface; and
 - a lower bone contact member having a lower bone contact surface.
2. The vertebral body replacement device of claim 1, wherein the inner housing and outer housing define a graft cavity for the placement of bone graft material.
3. The vertebral body replacement device of claim 1, wherein the upper bone contact member is pivotally connected to a portion of a top portion of the outer housing enabling the upper bone contact member to angulate in either an anterior or posterior direction.
4. The vertebral body replacement device of claim 1, wherein the lower bone contact member is pivotally connected to a portion of a lower portion of the inner housing enabling the lower bone contact member to angulate in either an anterior or posterior direction.
5. The vertebral body replacement device of claim 4, wherein at least one of the upper and lower bone contact members comprise means for locking the respective upper or lower bone contact member into a desired angular position.
6. The vertebral body replacement device of claim 5, wherein the means for locking the respective upper or lower bone contact member into a desired angular position comprises a wedge member configured to be removably positioned between the respective bone contact member and the housing to which the respective bone contact member is connected.
7. The vertebral body replacement device of claim 1, wherein at least one of the upper and lower contact surfaces define a plurality of surface protrusions configured to engage adjacent bony structure.
8. The vertebral body replacement device of claim 7, wherein the plurality of surface protrusions are spikes that can move from a undeployed state, where substantially all of the spike is beneath the respective contact surface, to a deployed state, where at least a portion of the spike extends above the respective contact surface.
9. The vertebral body replacement device of claim 8, further comprising means for deploying the spikes.
10. A method for replacing a vertebral body comprising the steps of:
 - accessing a desired motion segment;
 - removing a desired vertebral body;

- positioning an expandable VBR device in place of the removed vertebral body;
 - expanding the expandable VBR device; and
 - fixing the expandable VBR device in the expanded position; and
- wherein the VBR device comprises:
- an outer housing defining an interior cavity and having an interior toothed surface;
 - an inner housing nesting within at least a portion of the interior cavity of the outer housing, the inner housing moveable along a longitudinal direction to increase a height of the VBR device;
 - a retention member removably engageable with a portion of the inner housing, the retention member defining at least one outer edge that is cammed and complimentary to the interior toothed surface of the outer housing, wherein the retention member, when positioned in engagement with the inner housing, permits expansion of the vertebral body replacement device while preventing contraction of the vertebral body replacement device;
 - an upper bone contact member having an upper bone contact surface; and
 - a lower bone contact member having a lower bone contact surface.
11. The method of claim 10, wherein the inner housing and outer housing define a graft cavity for the placement of bone graft material and the method further comprises the step of packing the graft cavity with bone growth promoting materials.
 12. The method of claim 10, wherein the upper bone contact member is pivotally connected to a portion of a top portion of the outer housing enabling the upper bone contact member to angulate in either an anterior or posterior direction, and the lower bone contact member is pivotally connected to a portion of a lower portion of the inner housing enabling the lower bone contact member to angulate in either an anterior or posterior direction, the method further comprising the step of fixing a lordotic angle of at least one of the upper and lower bone contact members.
 13. A system for replacing a vertebral body comprising:
 - an expandable VBR device comprising:
 - an outer housing defining an interior cavity and having an interior toothed surface;
 - an inner housing nesting within at least a portion of the interior cavity of the outer housing, the inner housing moveable along a longitudinal direction to increase a height of the expandable VBR device;
 - a retention member removably engageable with a portion of the inner housing, the retention member defining at least one outer edge that is cammed and complimentary to the interior toothed surface of the outer housing, wherein the retention member, when positioned in engagement with the inner housing, permits expansion of the VBR device while preventing contraction of the expandable VBR device;
 - an upper bone contact member having an upper bone contact surface; and
 - a lower bone contact member having a lower bone contact surface; and
 - a VBR expansion tool.
 14. The system of claim 13, wherein the inner housing and outer housing define a graft cavity for the placement of bone graft material.

15. The system of claim **13**, wherein the upper bone contact member is pivotally connected to a portion of a top portion of the outer housing enabling the upper bone contact member to angulate in either an anterior or posterior direction and the lower bone contact member is pivotally connected to a portion of a lower portion of the inner housing enabling the lower bone contact member to angulate in either an anterior or posterior direction.

16. The system of claim **15**, wherein the VBR expansion tool comprises:

an actuation member having a first handle and an opposed second handle, wherein the first and second handles are hingedly coupled at a hinge point, the hinge point being positioned between a proximal end and a distal end of each of the first and second handles; and

a leveling member coupled to the actuation member, the leveling member having an upper leveling member and a lower leveling member, the upper and lower leveling members separated by and connected by a scissor member, wherein the scissor member comprises a first scissor arm and a second scissor arm pinned substantially in their middle section and wherein the proximal end of the first scissor arm is pinned to a proximal end of the upper leveling member and the distal end of the first scissor arm comprises a pin configured to engage, in sliding

relation, an elongate slot defined in the lower leveling member, and wherein the proximal end of the second scissor arm is pinned to a proximal end of the lower leveling member and the distal end of the second scissor arm comprises a pin configured to engage, in sliding relation, and elongate slot defined in the upper leveling member such that, as the proximal end of the upper leveling member is separated from the proximal end of the lower leveling member, the distal end of the upper leveling member is also raised and equally separated from the distal end of the lower leveling member.

17. The system of claim **16**, wherein the distal end of the first handle is hingedly connected to the proximal end of the upper leveling member and the distal end of the second handle can be hingedly connected to the proximal end of the lower leveling member.

18. The system of claim **16**, wherein the distal end of the upper and lower leveling members each comprise forks to engage portions of the expandable VBR device, whereby, in use, compression of the handles of the actuation member from a first, separated position to the second, compressed position, moves the leveling members from a position substantially adjacent one another to a separated position.

* * * * *