

(19) World Intellectual Property Organization  
International Bureau



(43) International Publication Date  
3 January 2003 (03.01.2003)

PCT

(10) International Publication Number  
WO 03/000090 A1

(51) International Patent Classification<sup>7</sup>: A46B 13/02

(21) International Application Number: PCT/KR02/01194

(22) International Filing Date: 24 June 2002 (24.06.2002)

(25) Filing Language: English

(26) Publication Language: English

(30) Priority Data:  
2001/19029 U 25 June 2001 (25.06.2001) KR

(71) Applicant and

(72) Inventor: LEE, Geunjae [KR/KR]; 101-1205 Samoh Apt., 1275, Shineum-dong, Kimcheon-si, Kyongsangbuk-do 740-150 (KR).

(74) Agents: PARK, Wonyong et al.; 6F, Yosam Bldg., 648-23 Yoksam-dong, Gangnam-gu, Seoul 135-080 (KR).

(81) Designated States (national): AE, AG, AL, AM, AT, AU, AZ, BA, BB, BG, BR, BY, BZ, CA, CH, CN, CO, CR, CU,

CZ, DE, DK, DM, DZ, EC, EE, ES, FI, GB, GD, GE, GH, GM, HR, HU, ID, IL, IN, IS, JP, KE, KG, KP, KZ, LC, LK, LR, LS, LT, LU, LV, MA, MD, MG, MK, MN, MW, MX, MZ, NO, NZ, OM, PH, PL, PT, RO, RU, SD, SE, SG, SI, SK, SL, TJ, TM, TN, TR, TT, TZ, UA, UG, US, UZ, VN, YU, ZA, ZM, ZW.

(84) Designated States (regional): ARIPO patent (GH, GM, KE, LS, MW, MZ, SD, SL, SZ, TZ, UG, ZM, ZW), Eurasian patent (AM, AZ, BY, KG, KZ, MD, RU, TJ, TM), European patent (AT, BE, CH, CY, DE, DK, ES, FI, FR, GB, GR, IE, IT, LU, MC, NL, PT, SE, TR), OAPI patent (BF, BJ, CF, CG, CI, CM, GA, GN, GQ, GW, ML, MR, NE, SN, TD, TG).

**Published:**

- with international search report
- before the expiration of the time limit for amending the claims and to be republished in the event of receipt of amendments

For two-letter codes and other abbreviations, refer to the "Guidance Notes on Codes and Abbreviations" appearing at the beginning of each regular issue of the PCT Gazette.

(54) Title: AUTOMATIC TOOTHBRUSH

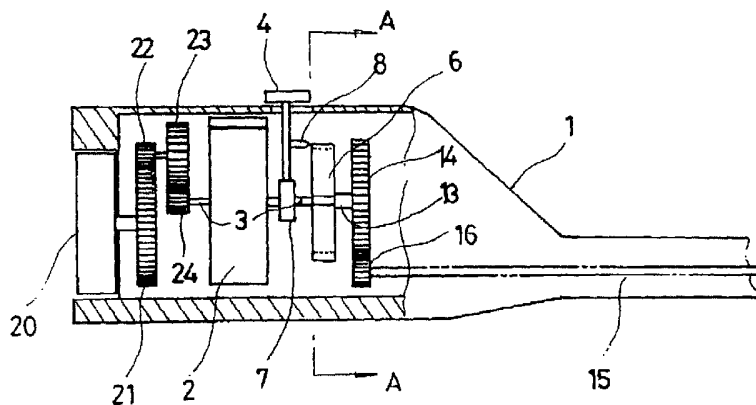

(57) Abstract: The present invention relates to an automatic toothbrush that can be used for cleaning one's teeth by converting elastic energy of a spiral spring into rotational energy. The present invention comprises a clutch section including a ratchet drum (5) on which a plurality of ratchets (9) are elastically mounted by a spring (10), a switch (4) which has a braking unit (7) and a stopper (8) fixedly mounted thereon, and a ratchet recess drum (6) which has a plurality of ratchet recesses (11) formed on the inner circumferential surface thereof and a plurality of stopper recesses (12) formed on the outer circumferential surface thereof; a toothbrush head driving section including a large gear (14) mounted on a second shaft (13) connected to the central portion of the ratchet recess drum (6), a small gear (16) to which a toothbrush head driving section (15) is fixed at one end, and a cone-shaped toothbrush head (19) with bristles having a square coupling mechanism (18) thereon; and a spiral spring winding section including a grip (20) formed on the end portion of the toothbrush body (1), a first large gear (21) coupled to the grip (20), a first small gear (22) engaged with the first large gear (21), a second large gear (23) coupled to the first small gear (22), and a second small gear (24) engaged with the second large gear (23) and rotatably mounted on the first shaft (3).



WO 03/000090 A1

## AUTOMATIC TOOTHBRUSH

### **Technical Field**

5           The present invention relates to an automatic toothbrush, and more particularly, to an automatic toothbrush which can be used for cleaning one's teeth by converting elastic energy of a spiral spring into rotational energy to rotate a toothbrush head.

### 10 **Background Art**

          In general, a toothbrush has an elongated handle and a toothbrush head with bristles formed on a front end of the handle and is used in such a way that a user holds the handle in hand and brushes his/her teeth with the bristles of the  
15 toothbrush head to remove food particles and dental plaque on or between his/her teeth.

          For such a toothbrush, since the teeth and gum may be damaged according to the degree of a force applied to the toothbrush head and the direction in which the user rubs the teeth with the bristles while grasping the handle, he/she has to  
20 pay a great attention to the brushing of teeth. Further, it has been known that he/she'd better brush his/her teeth upwardly and downwardly in order to keep them healthy.

          The way of brushing the teeth upwardly and downwardly, however, is very inconvenient and necessarily requires much time and efforts for the user to be  
25 accustomed thereto.

          Therefore, for the purpose of solving the aforementioned problems, there has been distributed an automatic toothbrush which can clean the teeth and protect the teeth and gum as well.

The conventional automatic toothbrush is largely classified into two type toothbrushes, i.e., one which rotates the bristles thereof using a storage battery or a dry battery and the other which rotates the bristles using a hydraulic pressure.

In particular, the battery-powered automatic toothbrush is effective in  
5 cleaning the teeth since the bristles of the toothbrush rotate by means of a motor.

However, the conventional battery-powered automatic toothbrush has a disadvantage of high purchasing costs since a reducer and a battery charger including the motor are also needed. It has another disadvantage of requiring a cost of maintenance since it utilizes electricity and the battery to drive the motor.  
10 It has still another disadvantage of increasing the possibility of failure unless measures for waterproofing, insect-proofing, and electric discharge are taken.

In the meantime, the hydraulically actuated toothbrush can be used without electricity. But, it is complex in structure due to the use of a hose and water, and fails to put to practical use due to troublesomeness in use.

15

### **Disclosure of Invention**

Accordingly, the present invention is directed to an automatic toothbrush that substantially obviates one or more problems due to limitations and  
20 disadvantages of the related art.

An object of the present invention is to provide an automatic toothbrush which can be used for cleaning one's teeth in such a manner that a plurality of large and small gears and a spiral spring are installed inside a toothbrush body to be coupled to a cone-shaped toothbrush head with bristles, the spiral spring is  
25 manually wound to produce elastic energy, and then the elastic energy of the spiral spring is converted into rotational energy upon brushing the teeth to rotate the cone-shaped toothbrush head.

Additional advantages, objects, and features of the invention will be set forth in part in the description which follows and in part will become apparent to

those having ordinary skill in the art upon examination of the following or may be learned from practice of the invention. The objectives and other advantages of the invention may be realized and attained by the structure particularly pointed out in the written description and claims hereof as well as the appended drawings.

5 To achieve these objects and other advantages and in accordance with the purpose of the invention, as embodied and broadly described herein, there is provided an automatic toothbrush comprising: a clutch section including a ratchet drum on which a plurality of ratchets are elastically mounted by a spring in such a manner that the external end of a spiral spring is fixed to the inner wall of a  
10 toothbrush body and the internal end of the spiral spring is fixed to a first shaft, a switch which has a braking unit and a stopper fixedly mounted thereon, the braking unit being mounted on the first shaft, and a ratchet recess drum which has a plurality of ratchet recesses formed on the inner circumferential surface thereof and a plurality of stopper recesses formed on the outer circumferential surface  
15 thereof; a toothbrush head driving section including a large gear mounted on a second shaft connected to the central portion of the ratchet recess drum, a small gear to which a toothbrush head driving shaft is at one end fixed and which is engaged with the large gear, the toothbrush head driving shaft having a square recess formed at the other end thereof, and a cone-shaped toothbrush head on  
20 which a square coupling mechanism is formed; and a spiral spring winding section including a grip formed on the end portion of the toothbrush body, a first large gear coupled to the grip, a first small gear engaged with the first large gear, a second large gear coupled to the first small gear, and a second small gear engaged with the second large gear and rotatably mounted on the first shaft which is fixed  
25 to the internal end of the spiral spring.

It is to be understood that both the foregoing general description and the following detailed description of the present invention are exemplary and explanatory and are intended to provide further explanation of the invention as claimed.

### **Brief Description of the Drawings**

Further objects and advantages of the invention can be more fully understood from the following detailed description taken in conjunction with the accompanying drawing in which:

FIG. 1 is a perspective view illustrating the outer construction of the present invention;

FIG. 2 is a perspective view illustrating the inner construction of the present invention;

FIG. 3 is a cross-sectional view illustrating the inner construction of the present invention;

FIG. 4 is a cross-sectional view taken along the line A-A of FIG. 3;

FIGs. 5 and 6 are side views illustrating the states before and after a switch is actuated according to the present invention, respectively; and

FIG. 7 is a cross-sectional view illustrating the coupling relation between a toothbrush driving shaft and a cone-shaped toothbrush head.

### **Best Mode for Carrying Out the Invention**

The present invention will now be described in detail in connection with preferred embodiments with reference to the accompanying drawings. In the drawings, the same or similar elements are denoted by the same reference numerals even though they are depicted in different drawings.

Referring to the figures, the external end of a spiral spring 2 is fixed to the inner wall of a toothbrush body 1 while the internal end of the spiral spring is fixed to a first shaft 3. A spiral spring winding section is formed on one side of the spiral spring 2 and a clutch section and a toothbrush head driving section are

formed on the other side thereof opposite to the spiral spring winding section.

The clutch section includes an on-off switch 4, a ratchet drum 5, and a ratchet recess drum 6. The on-off switch 4 includes a stopper 8 and a braking unit 7 which is mounted on the first shaft 3 that connects the spiral spring 2 and the ratchet drum 5.

A plurality of ratchets 9 mounted on the ratchet drum 5 are coupled to a spring 10, such that they are maintained in a spread state unless an external force is applied thereto.

The ratchet recess drum 6 has a plurality of ratchet recesses 11 formed on the inner circumferential surface thereof so that the ratchets 9 can be inserted into the ratchet recesses 11, and a plurality of stopper recesses 12 formed on the external circumferential surface thereof.

The toothbrush head driving section includes a large gear 14 mounted on a second shaft 13 connected to the central portion of the ratchet recess drum 6, a small gear 16 to which a toothbrush head driving shaft 15 is at one end fixed and which is engaged with the large gear 14, the toothbrush head driving shaft 15 having a square recess 17 formed at the other end thereof, and a cone-shaped toothbrush head 19 with bristles having a square coupling mechanism 18 formed thereon so that it is fitted into the square recess 17.

The spiral spring winding section includes a grip formed on the end portion of the toothbrush body 1, a first large gear 21 coupled to the grip 20, a first small gear 22 engaged with the first large gear 21, a second large gear 23 coupled to the first small gear 22, and a second small gear 24 engaged with the second large gear 23 and rotatably mounted on the first shaft 3 which is fixed to the internal end of the spiral spring 2.

An unexplained reference numeral 50 denotes a cone-shaped toothbrush head cover.

The operation of the automatic toothbrush constructed as above will be explained in detail hereinbelow.

Initially, as a pre-step for cleaning the teeth, a step for preparing for a driving force for rotating the cone-shaped toothbrush head 19 is needed.

5 To do that, the switch 4 is pushed up to the position OFF such that the stopper 8 is inserted into one of the stopper recesses 12 formed on the ratchet recess drum 6, thereby preventing the ratchet drum 6 from rotating.

In this state, when the grip 20 included in the spiral spring winding section is turned, since the first large gear 21, the first small gear 22, the second large gear 10 23, and the second small gear 24 are engaged with one another, the first shaft 3 on which the second small gear 24 is fixedly mounted rotates and thus the spiral spring 2 fixed to the first shaft 3 is wound. At this moment, the ratchet drum 5 also rotates together. While the ratchets 9 rotate in a direction in which the spring 10 is pressed down, if the rotation of the grip 20 is stopped, the ratchet 15 drum 5 and the ratchets 9 are forced to rotate in a reverse direction.

However, since the ratchets 9 are inserted into the ratchet recesses 11 while being spread by virtue of the elasticity of the spring, the spiral spring 2 doesn't come loose.

In the above described operation, since the first and second large and small 20 gears are adopted to completely wind the spiral spring 2 and store the elasticity, even though the grip is turned in a small number of times, the spiral spring 2 can be fast wound.

In this state, when the user spreads toothpaste on the bristles of the cone-shaped toothbrush head 19 and pulls down the switch 4 to the position ON to pull 25 out the stopper 8 which is inserted into one of the stopper recesses 12 formed on the ratchet recess drum 6, the ratchet recess drum 6 rotates by means of the ratchet recess 11, the ratchets 9 and the ratchet drum 5, which is mounted on the first shaft

3, due to the elasticity stored in the spiral spring 2.

On account of the rotational energy obtained in this way, the small gear 16 coupled to the toothbrush head driving shaft 15 rotates through the large gear 14, and finally the cone-shaped toothbrush head 19 coupled to the toothbrush head driving shaft 15 rotates, whereby the user can brush his/her teeth.

Throughout the above operation, the rotation of the bristles of the cone-shaped toothbrush head 19 at a suitable speed is determined based on the ratio of the gears but can be affected by a frictional force of the braking unit 7 which is disposed on the lower portion of the switch 4 and mounted on the first shaft 3. In consequence, the proper rotational speed for brushing of teeth can be maintained. After the user finishes the brushing, he/she pushes up the switch 4 to the position OFF and inserts the stopper 8 to one of the stopper recesses 12 formed on the ratchet recess drum 6 to fix the ratchet drum 5, thereby preventing the ratchet drum from rotating.

The square recess 17 is formed on the other end of the toothbrush driving shaft 15 and the square coupling mechanism 18 is formed on the cone-shaped toothbrush head 19, so that the cone-shaped toothbrush head 19 can be easily replaced with new one when being worn.

## 20 **Industrial Applicability**

As described above, the present invention has an advantage of being inexpensively supplied since the large and small gears and the spiral spring are wound to produce elastic energy and thereafter the elastic energy is converted into rotational energy to rotate the cone-shaped toothbrush head, so that a user can brush his/her teeth.

The present invention has a further advantage of being economically used

since the costs of maintenance are not incurred.

The present invention has another advantage of being semi-permanently used since it is strong enough to resist damp and insects and the cone-shaped toothbrush head can be replaced.

5           The present invention has yet another advantage of helping the user to keep one's teeth and gum healthy since the cone-shaped toothbrush head rotates and the user can properly brush his/her teeth in a natural way.

10           While the present invention has been described with reference to the particular illustrative embodiments, it is not to be restricted by the embodiments but only by the appended claims. It is to be appreciated that those skilled in the art can change or modify the embodiments without departing from the scope and spirit of the present invention.

**What Is Claimed Is:**

1. An automatic toothbrush, comprising:

5 a clutch section including a ratchet drum(5) on which a plurality of ratchets(9) are elastically mounted by a spring(10) in such a manner that the external end of a spiral spring(2) is fixed to the inner wall of a toothbrush body(1) and the internal end of the spiral spring(2) is fixed to a first shaft(3), a switch(4) which has a braking unit(7) and a stopper(8) fixedly mounted thereon, the braking unit(7) being mounted on the first shaft(3), and a ratchet recess drum(6) which has  
10 a plurality of ratchet recesses(11) formed on the inner circumferential surface thereof and a plurality of stopper recesses(12) formed on the outer circumferential surface thereof;

a toothbrush head driving section including a large gear(14) mounted on a second shaft(13) connected to the central portion of the ratchet recess drum(6), a  
15 small gear(16) to which a toothbrush head driving shaft(15) is at one end fixed and which is engaged with the large gear(14), the toothbrush head driving shaft(15) having a square recess(17) formed at the other end thereof, and a cone-shaped toothbrush head(19) with bristles having a square coupling mechanism(18) formed thereon so that it is fitted into the square recess; and

20 a spiral spring winding section including a grip(20) formed on the end portion of the toothbrush body(1), a first large gear(21) coupled to the grip(20), a first small gear(22) engaged with the first large gear(21), a second large gear(23) coupled to the first small gear(22), and a second small gear(24) engaged with the second large gear(23) and rotatably mounted on the first shaft(3) which is fixed to  
25 the internal end of the spiral spring(2).

FIG. 1

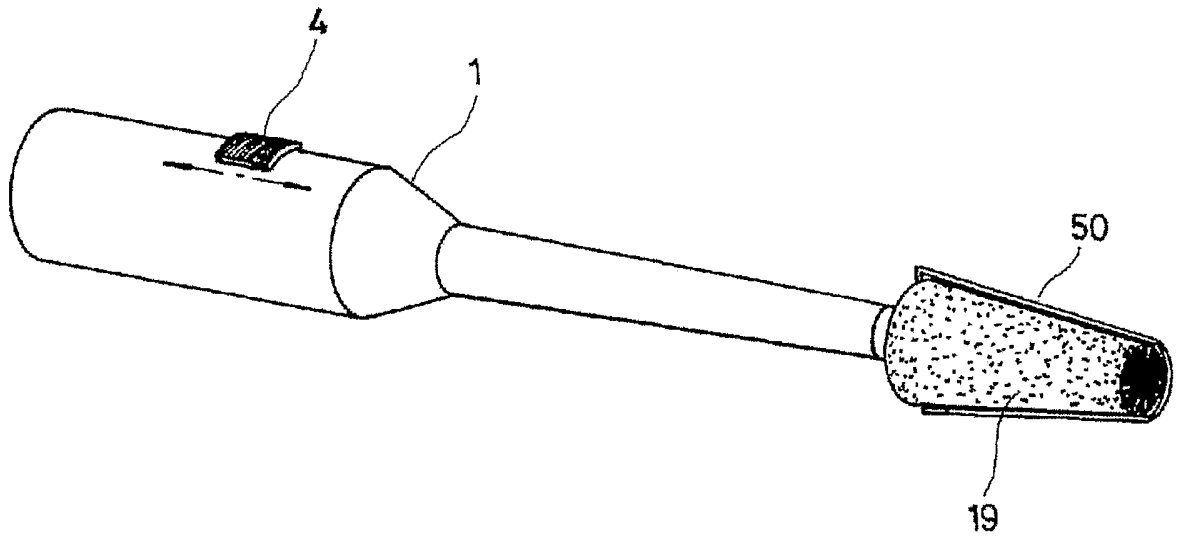

FIG. 2

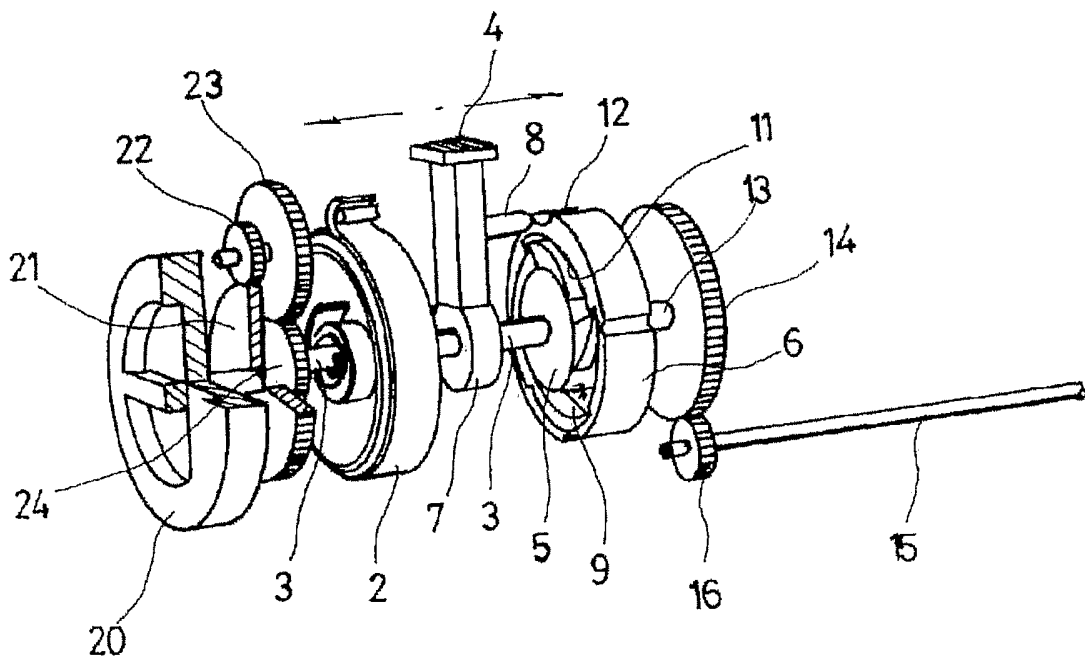

FIG. 3

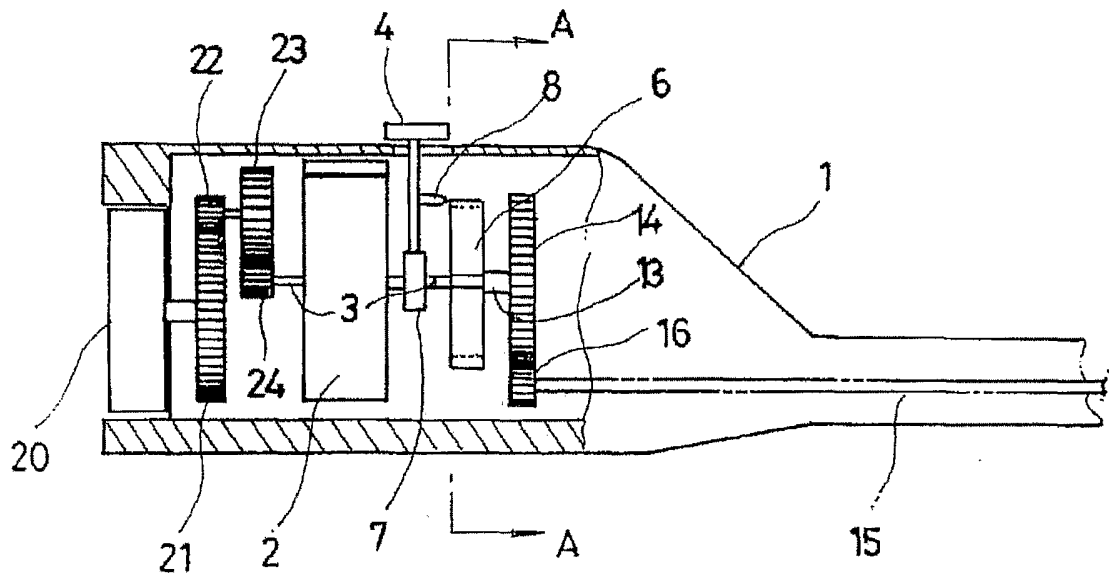

FIG. 4

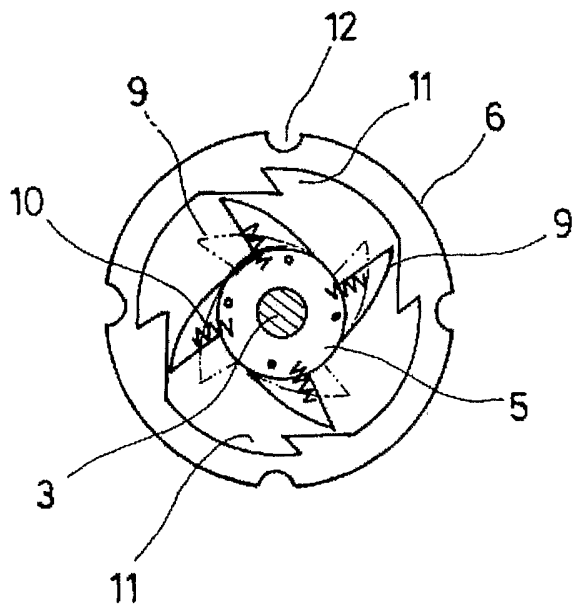

FIG. 5

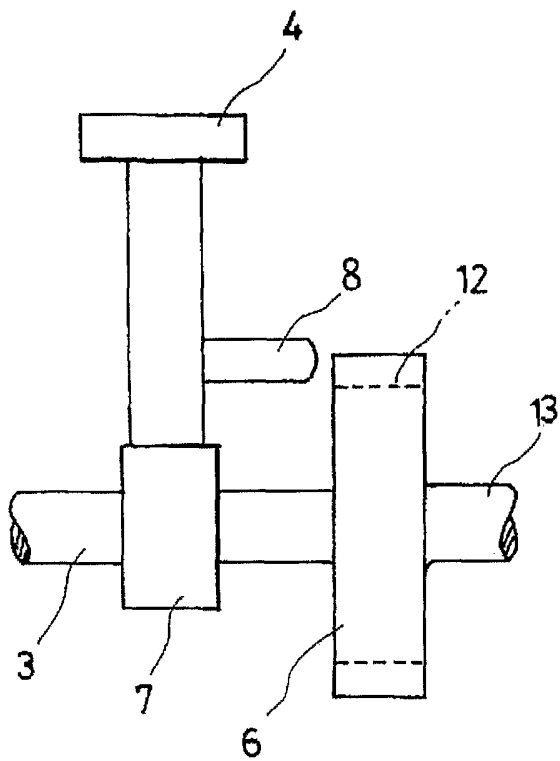

FIG. 6

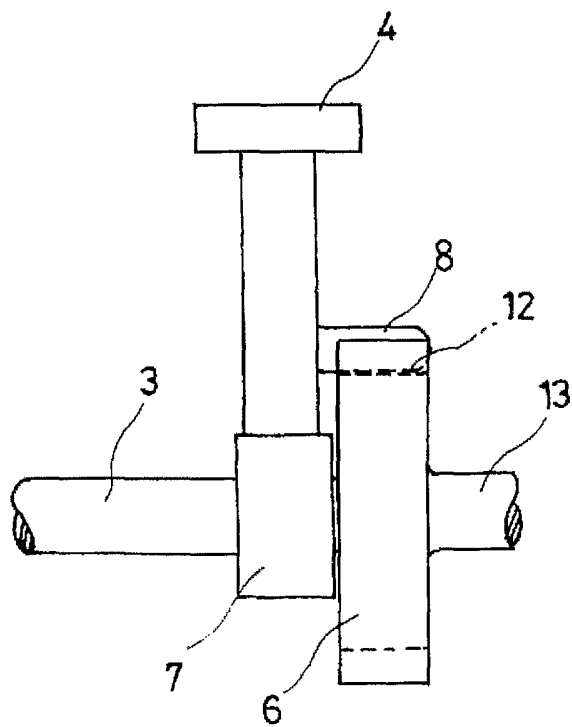
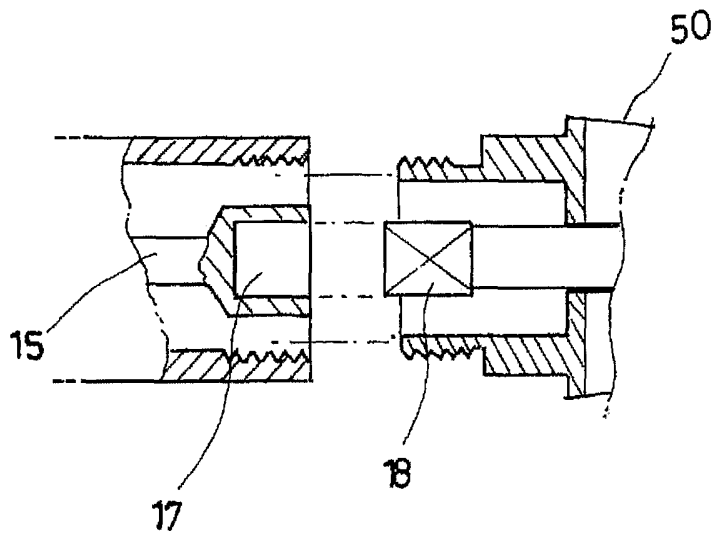



FIG. 7

4/4



## INTERNATIONAL SEARCH REPORT

International application No.  
PCT/KR02/01194

<b>A. CLASSIFICATION OF SUBJECT MATTER</b>		
IPC7 A46B 13/02		
According to International Patent Classification (IPC) or to both national classification and IPC		
<b>B. FIELDS SEARCHED</b>		
Minimum documentation searched (classification system followed by classification symbols) IPC7 A46B		
Documentation searched other than minimum documentation to the extent that such documents are included in the fields searched KR, JP as above		
Electronic data base consulted during the international search (name of data base and, where practicable, search terms used)		
<b>C. DOCUMENTS CONSIDERED TO BE RELEVANT</b>		
Category*	Citation of document, with indication, where appropriate, of the relevant passages	Relevant to claim No.
A	US 4 603 448 A (FREDERIC H. MIDDLETON et al) 05 August 1986 see the whole document; figures	1
A	US 5 035 020 A (GERALD WINIEWSKI) 30 July 1991 see the whole document; figures	1
A	US 6 148 462 A (CHUN LIN ZSENG) 21 November 2000 see the whole document; figures	1
A	KR 89-17047 U (KIM, JAE DUCK) 06 September 1989 see claim 1; figures	1
A	KR 89-18683 U (KIM, SAM GIL) 05 October 1989 see claim 1; figures	1
<input type="checkbox"/> Further documents are listed in the continuation of Box C. <input checked="" type="checkbox"/> See patent family annex.		
* Special categories of cited documents: "A" document defining the general state of the art which is not considered to be of particular relevance "E" earlier application or patent but published on or after the international filing date "L" document which may throw doubts on priority claim(s) or which is cited to establish the publication date of citation or other special reason (as specified) "O" document referring to an oral disclosure, use, exhibition or other means "P" document published prior to the international filing date but later than the priority date claimed "T" later document published after the international filing date or priority date and not in conflict with the application but cited to understand the principle or theory underlying the invention "X" document of particular relevance; the claimed invention cannot be considered novel or cannot be considered to involve an inventive step when the document is taken alone "Y" document of particular relevance; the claimed invention cannot be considered to involve an inventive step when the document is combined with one or more other such documents, such combination being obvious to a person skilled in the art "&" document member of the same patent family		
Date of the actual completion of the international search 21 OCTOBER 2002 (21.10.2002)		Date of mailing of the international search report 21 OCTOBER 2002 (21.10.2002)
Name and mailing address of the ISA/KR  Korean Intellectual Property Office 920 Dunsan-dong, Seo-gu, Daejeon 302-701, Republic of Korea Facsimile No. 82-42-472-7140		Authorized officer LEE, Min Hyung Telephone No. 82-42-481-5997 

## INTERNATIONAL SEARCH REPORT

International application No.

PCT/KR02/01194

Patent document cited in search report	Publication date	Patent family member(s)	Publication date
US 4 603 448 A	05-08-86	EP 206574 A1 EP 206574 B1 US 4603448 A	30-12-86 04-04-90 05-08-86
US 5 035 020 A	30-07-91	NONE	
US 6 148 462 A	21-11-00	NONE	
KR 89-17047 U	06-09-89	NONE	
KR 89-18683 U	05-10-89	NONE	