



US 20030140835A1

(19) **United States**

(12) **Patent Application Publication**  
**Wrage**

(10) **Pub. No.: US 2003/0140835 A1**

(43) **Pub. Date: Jul. 31, 2003**

(54) **WIND-PROPELLED WATERCRAFT**

**Publication Classification**

(76) Inventor: **Stephan Wrage, Hamburg (DE)**

(51) **Int. Cl.<sup>7</sup> ..... B63H 9/04**

(52) **U.S. Cl. .... 114/102.1**

Correspondence Address:

**LEYDIG VOIT & MAYER, LTD  
TWO PRUDENTIAL PLAZA, SUITE 4900  
180 NORTH STETSON AVENUE  
CHICAGO, IL 60601-6780 (US)**

(57) **ABSTRACT**

The invention relates to a wind-propelled watercraft by means of which in contrast to the conventional solutions the wind forces can be better utilized for the propulsion, and the turning moments about the longitudinal axis acting on the body of the watercraft and the hull, respectively can be reduced. With this, a sheet element is held with at least one stay rope in close proximity to the body of the watercraft, and the one or else a plurality of stay ropes are attached to at least three points of the sheet element spaced to one another. In addition, the point of application of force of the one or else a plurality of stay ropes on the body of the watercraft can be varied depending on the wind direction and direction of motion.

(21) Appl. No.: **10/296,649**

(22) PCT Filed: **May 31, 2001**

(86) PCT No.: **PCT/DE01/02124**

(30) **Foreign Application Priority Data**

May 31, 2000 (DE)..... 100 27 691.1  
Dec. 21, 2000 (DE)..... 100 65 630.7

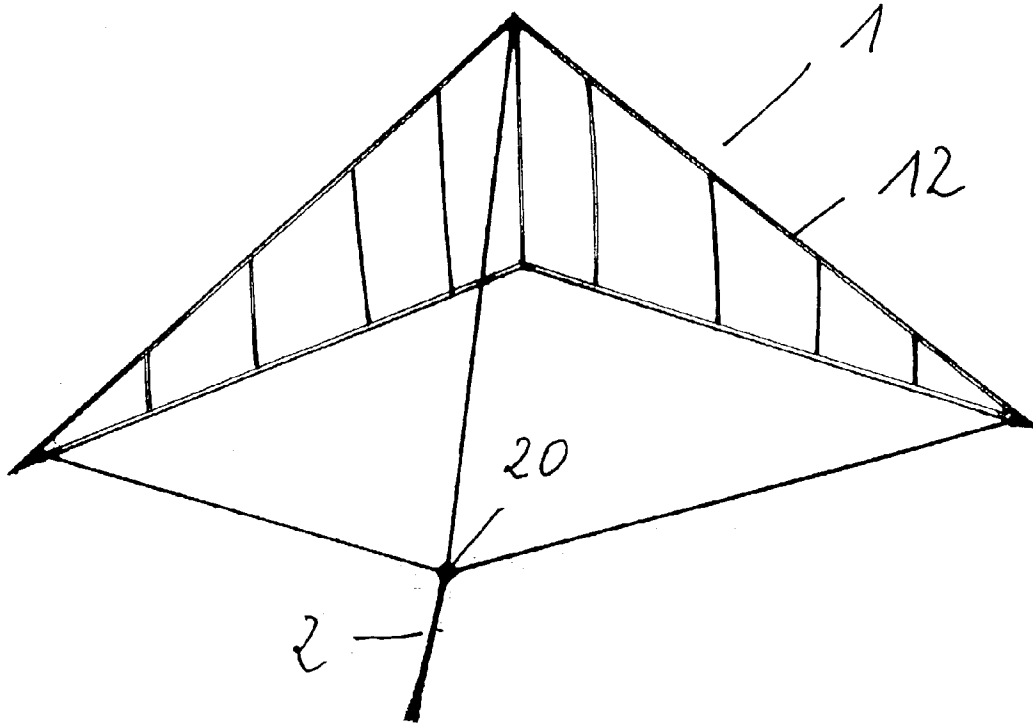

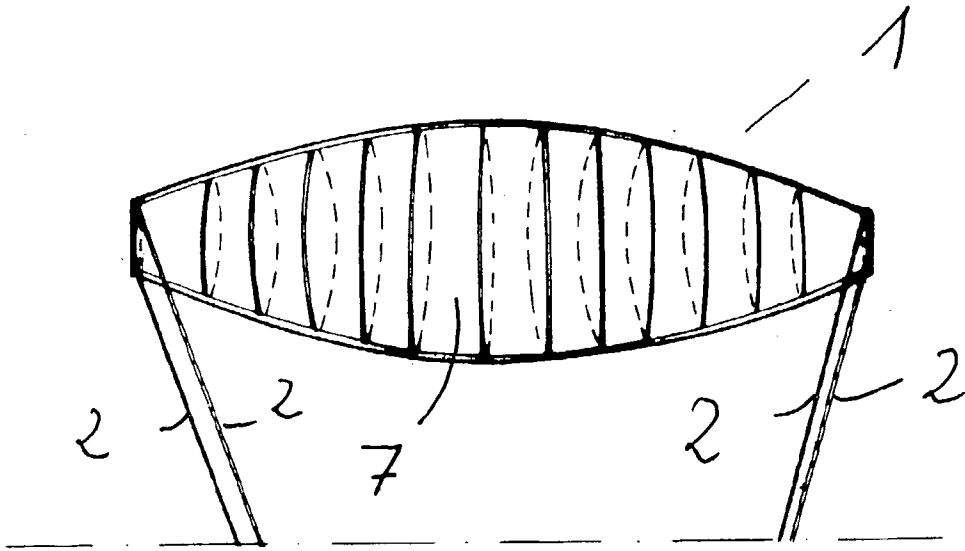

Figure 1

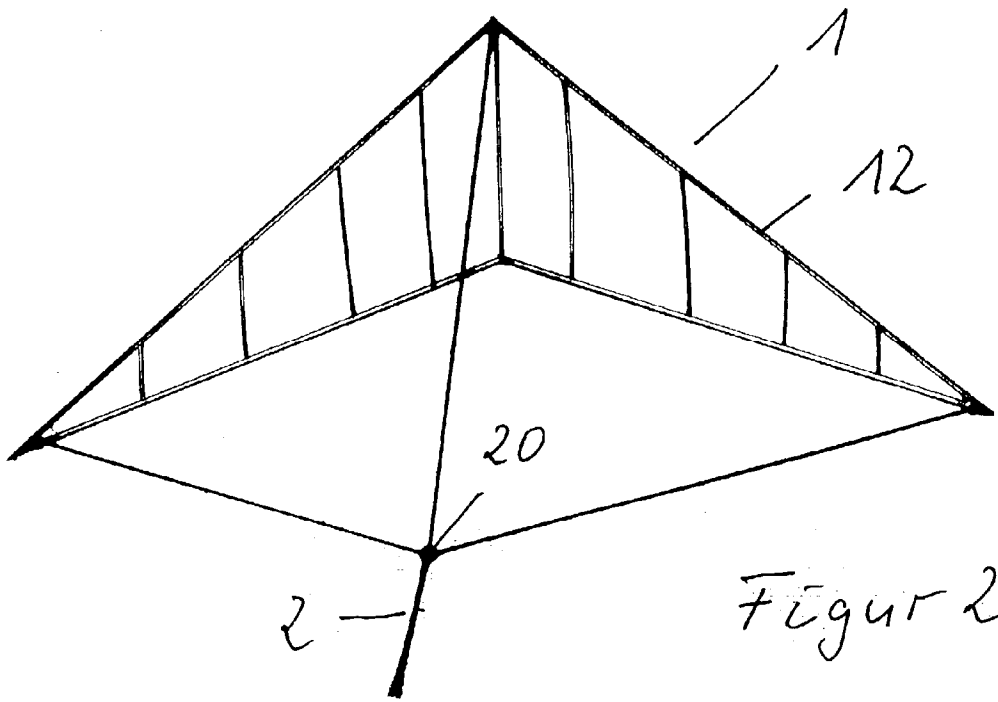

Figure 2

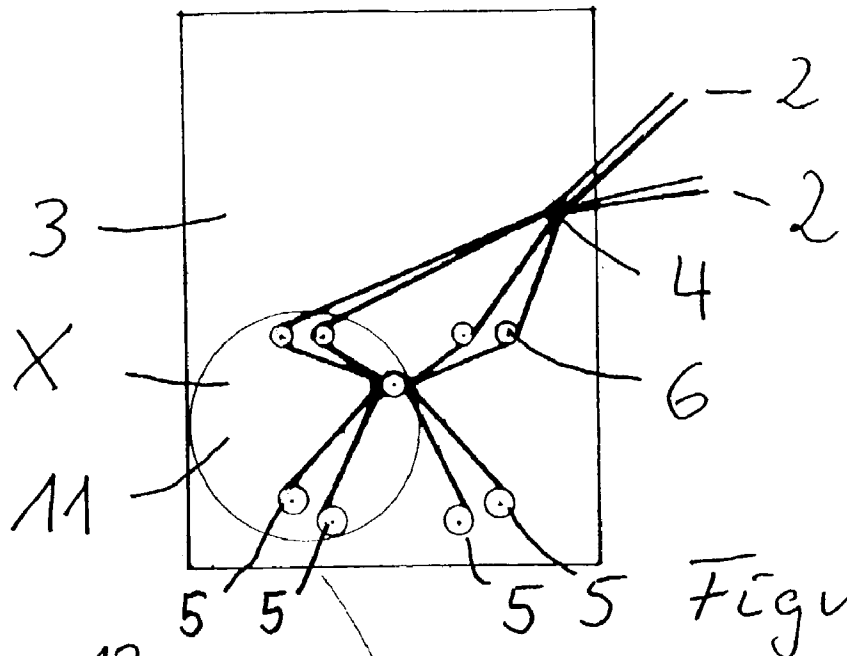

Figure 3

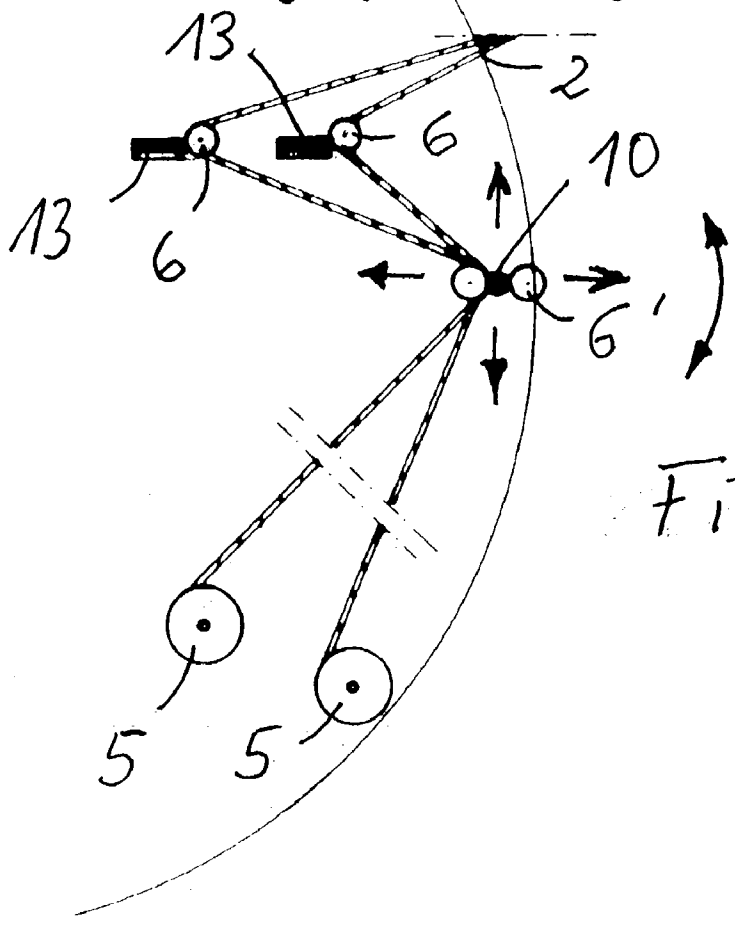
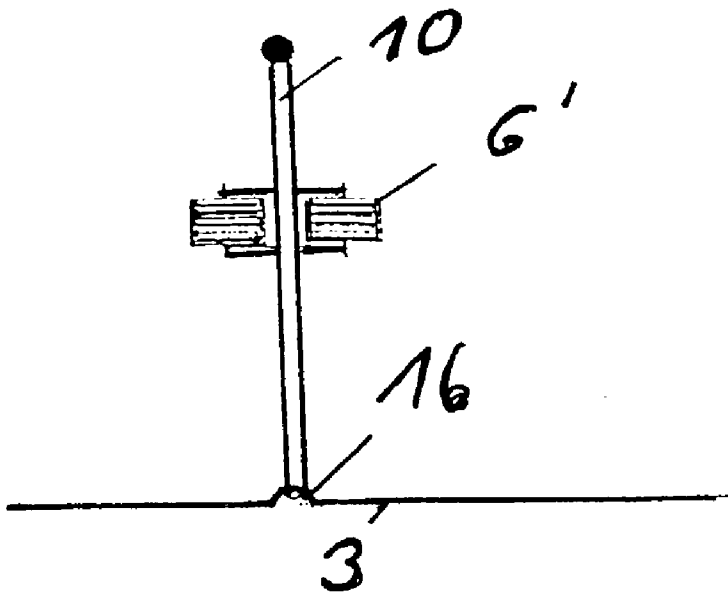
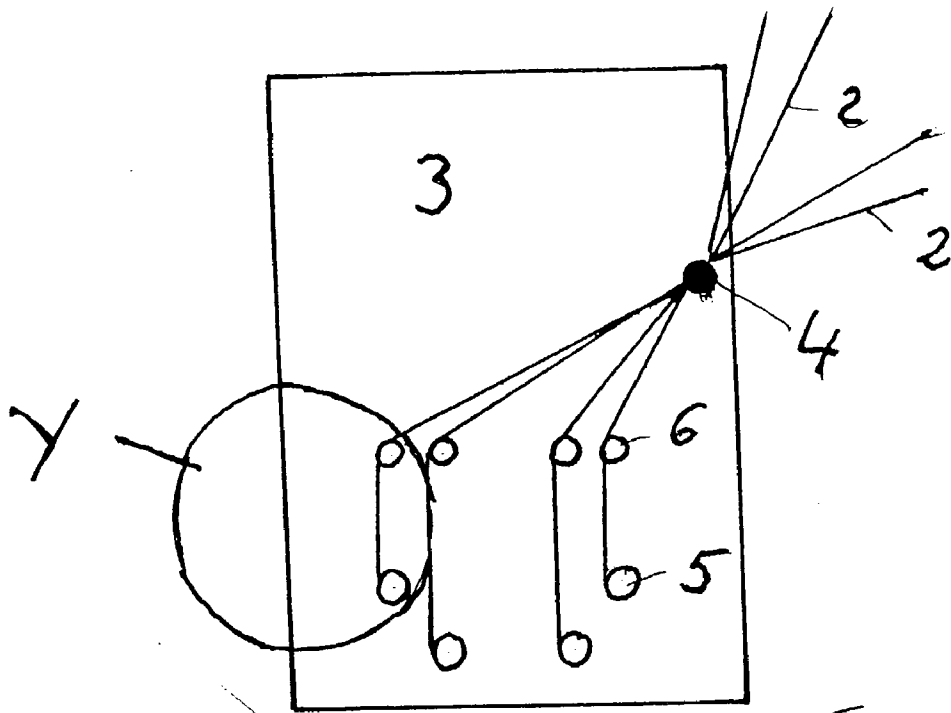

Figure 3a



Figur 3b



Figur 4

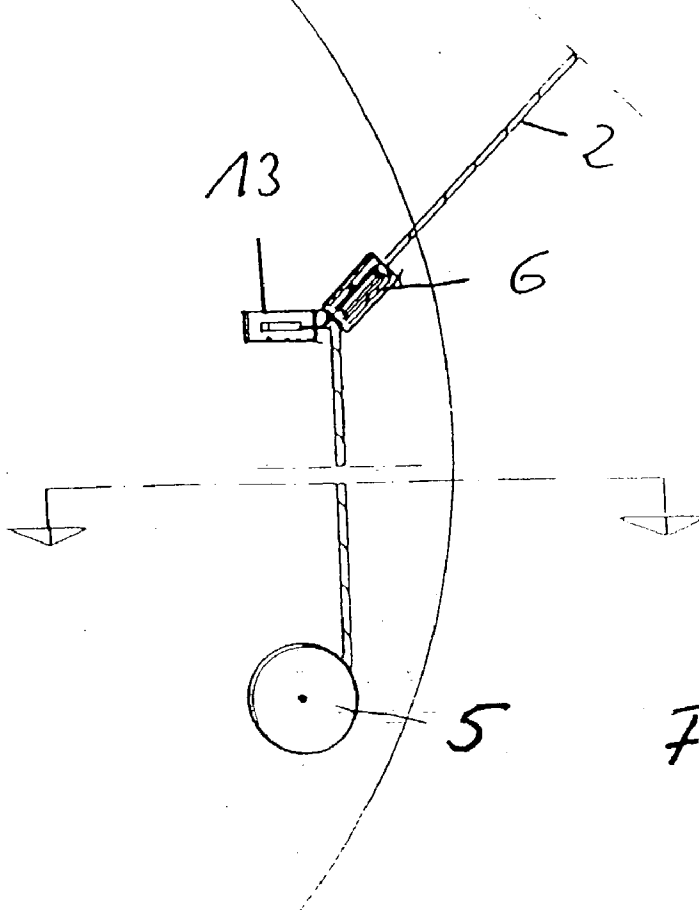

Figur 4a

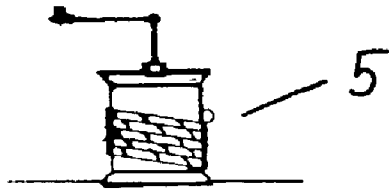

Figur 4b

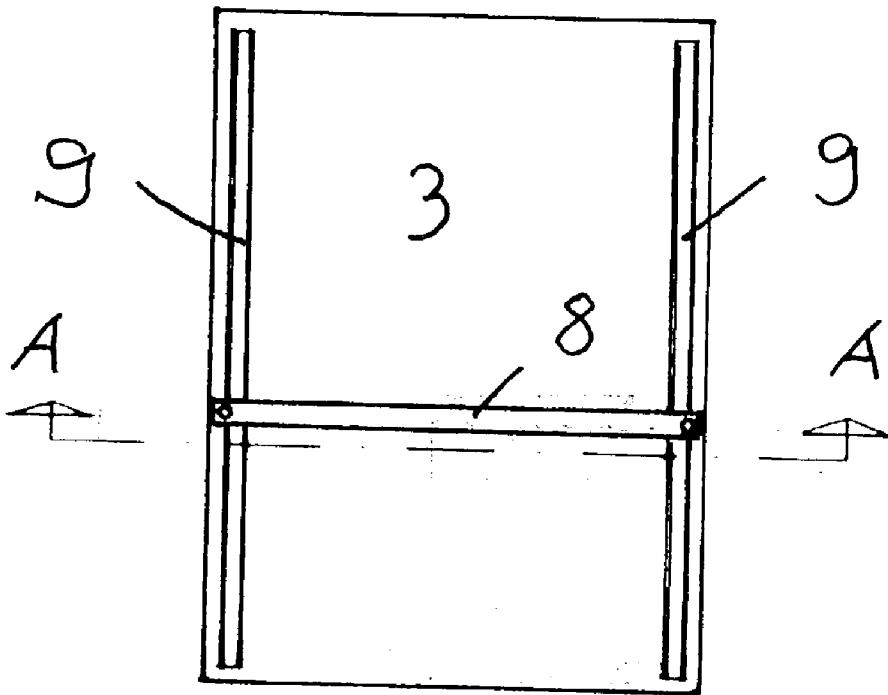

Figur 5

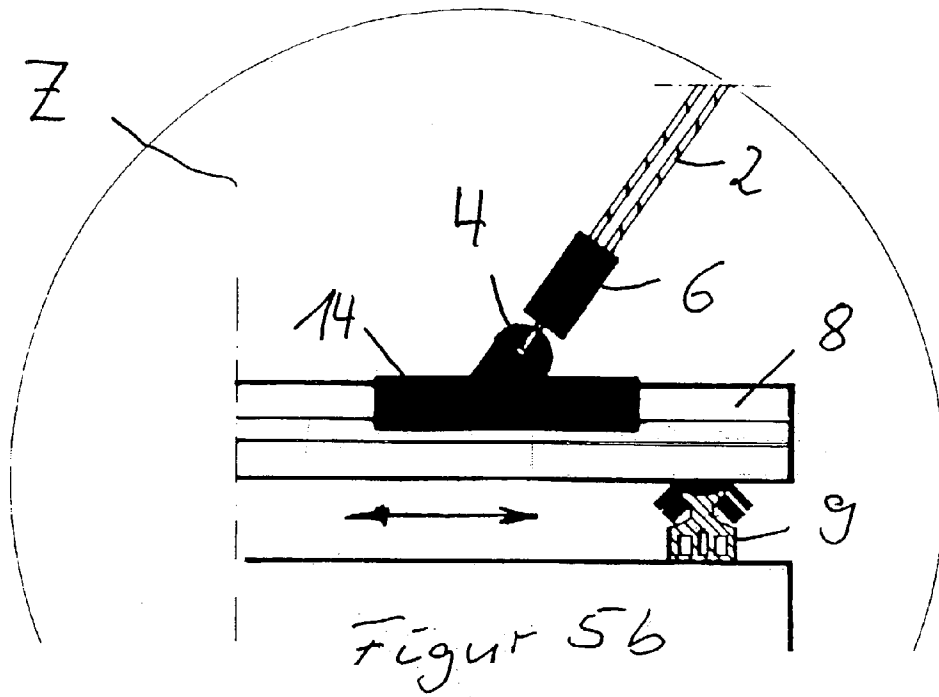
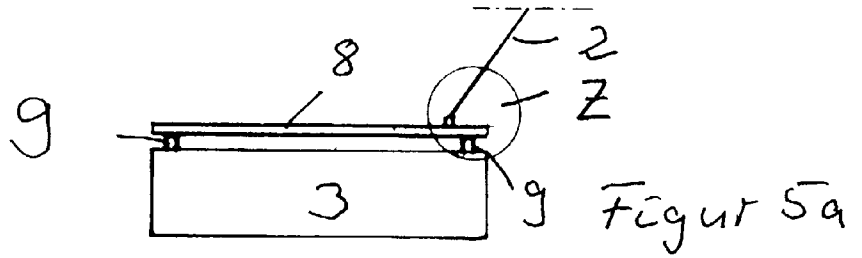

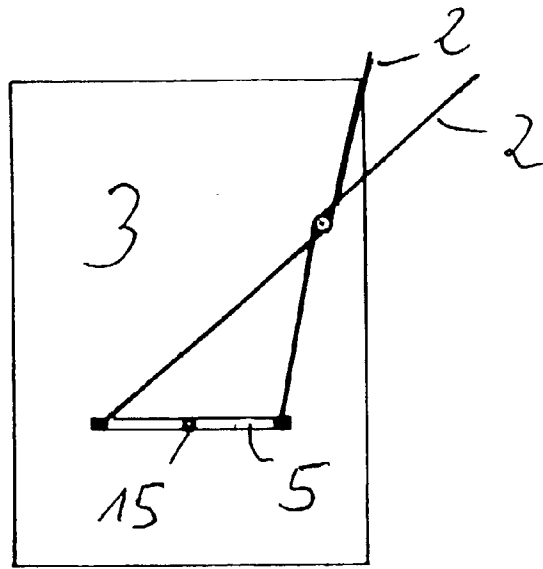

Figure 6

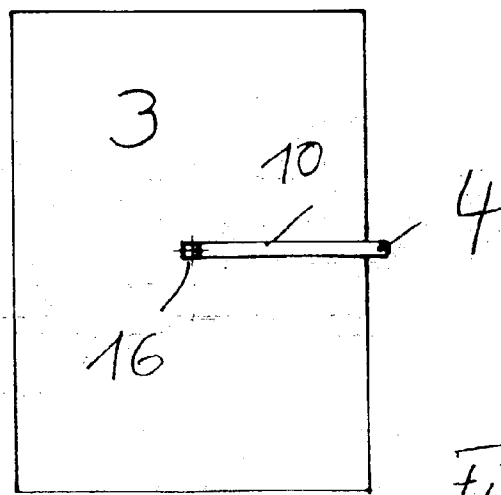
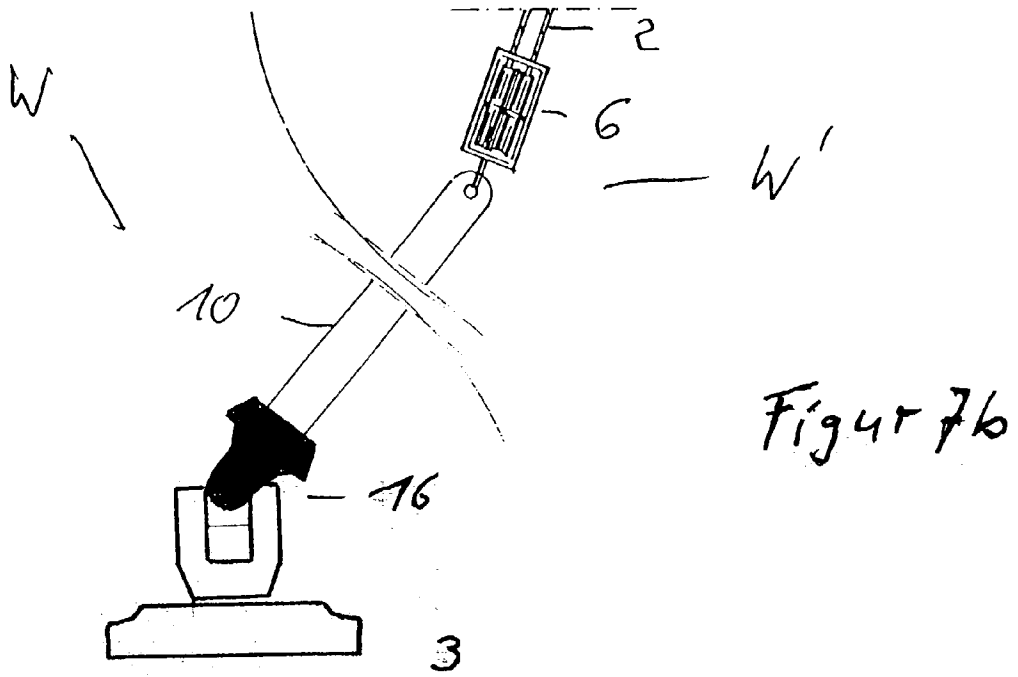
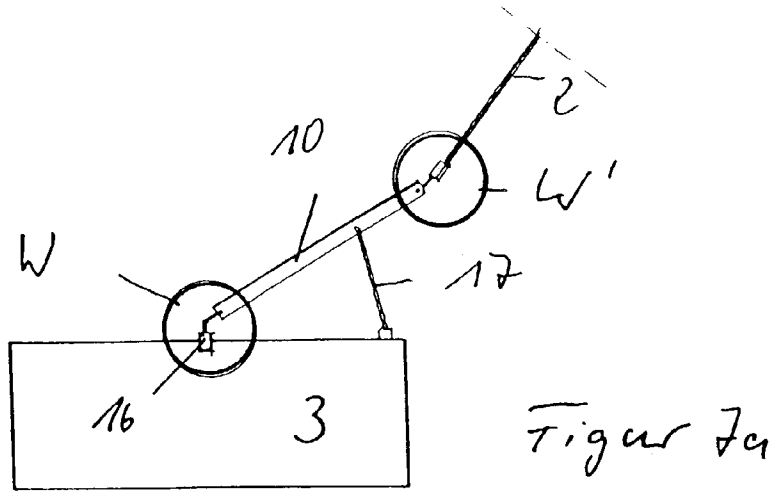
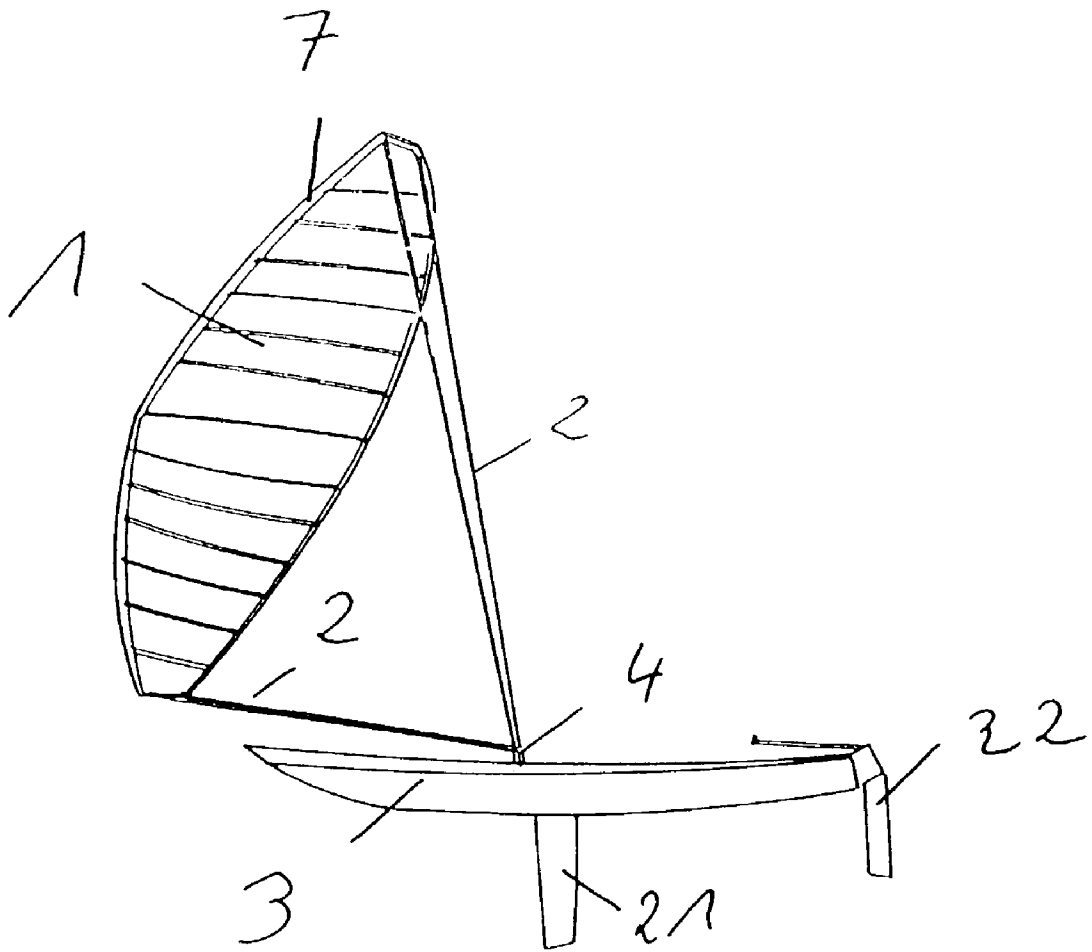

Figure 7







Figur 9

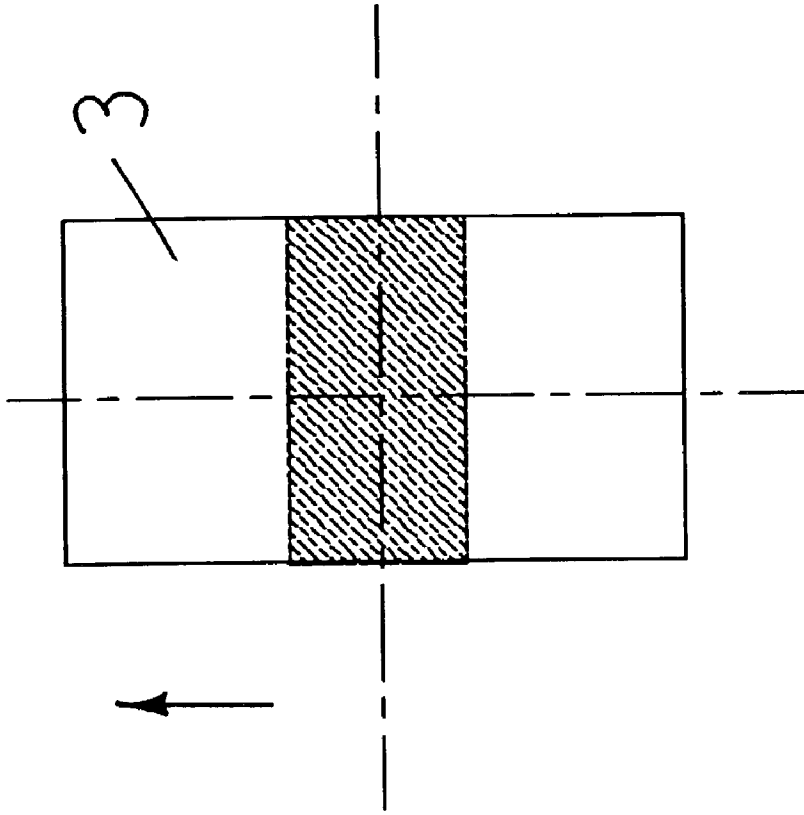

Figure 11

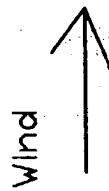
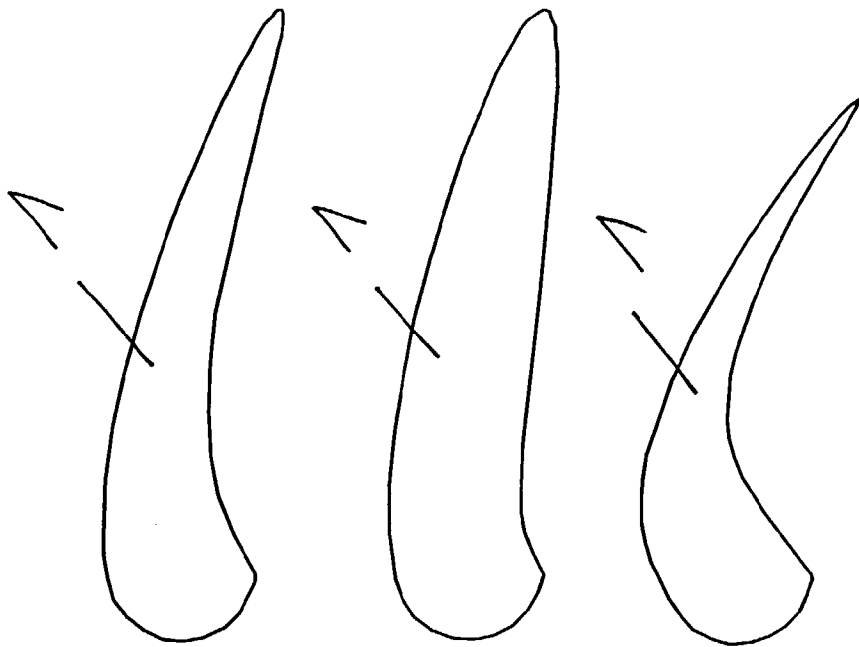
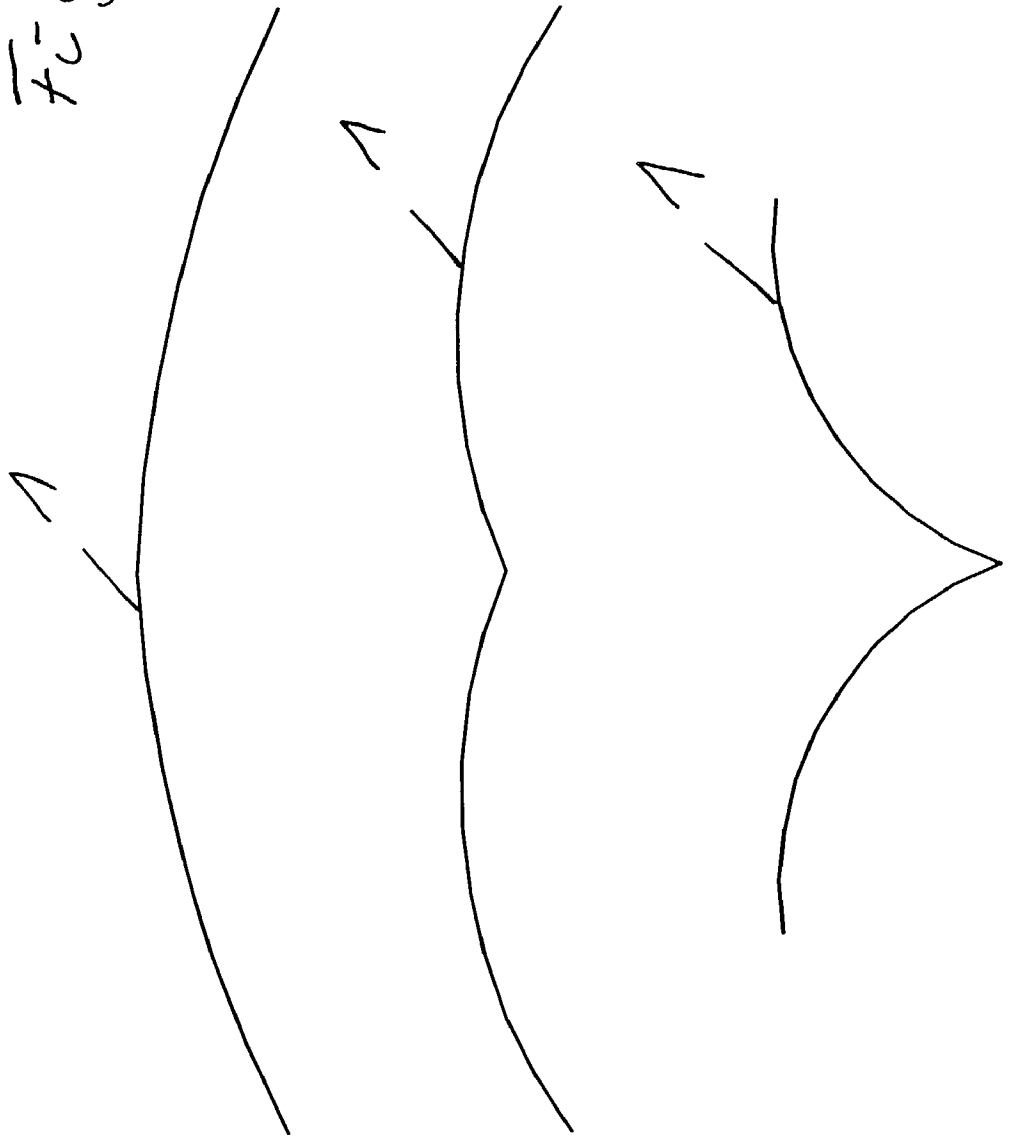
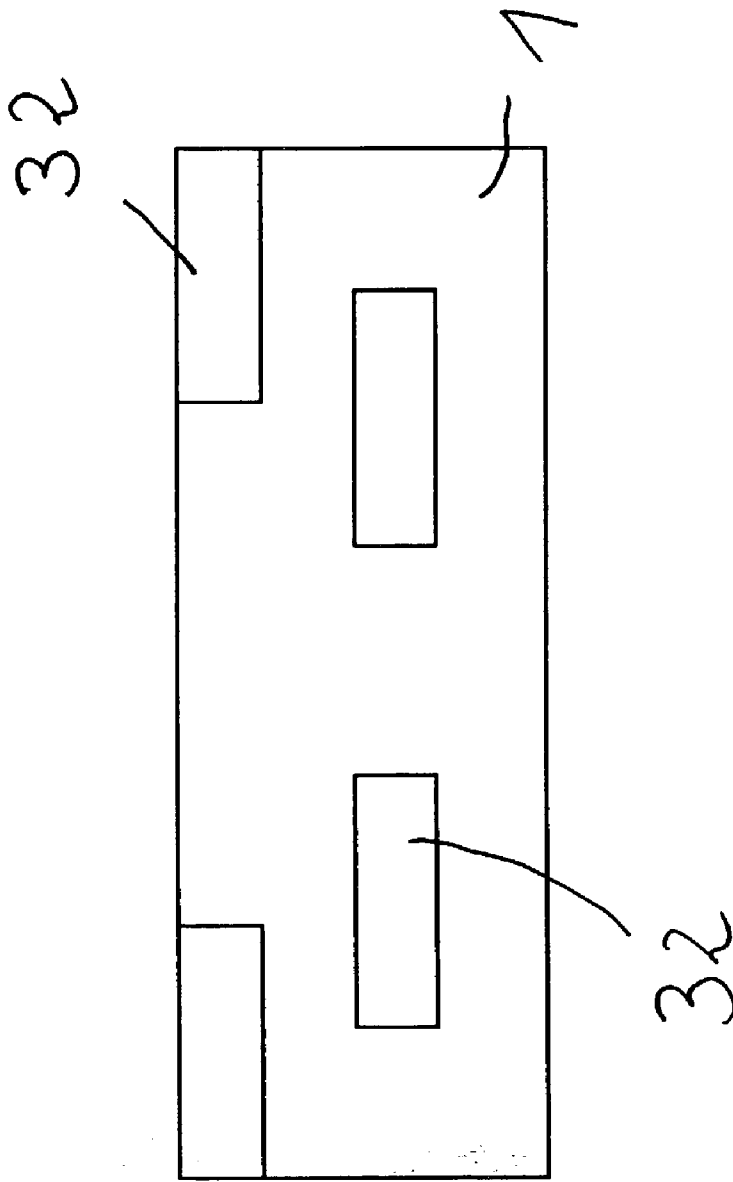

Figure 12





Figur 13

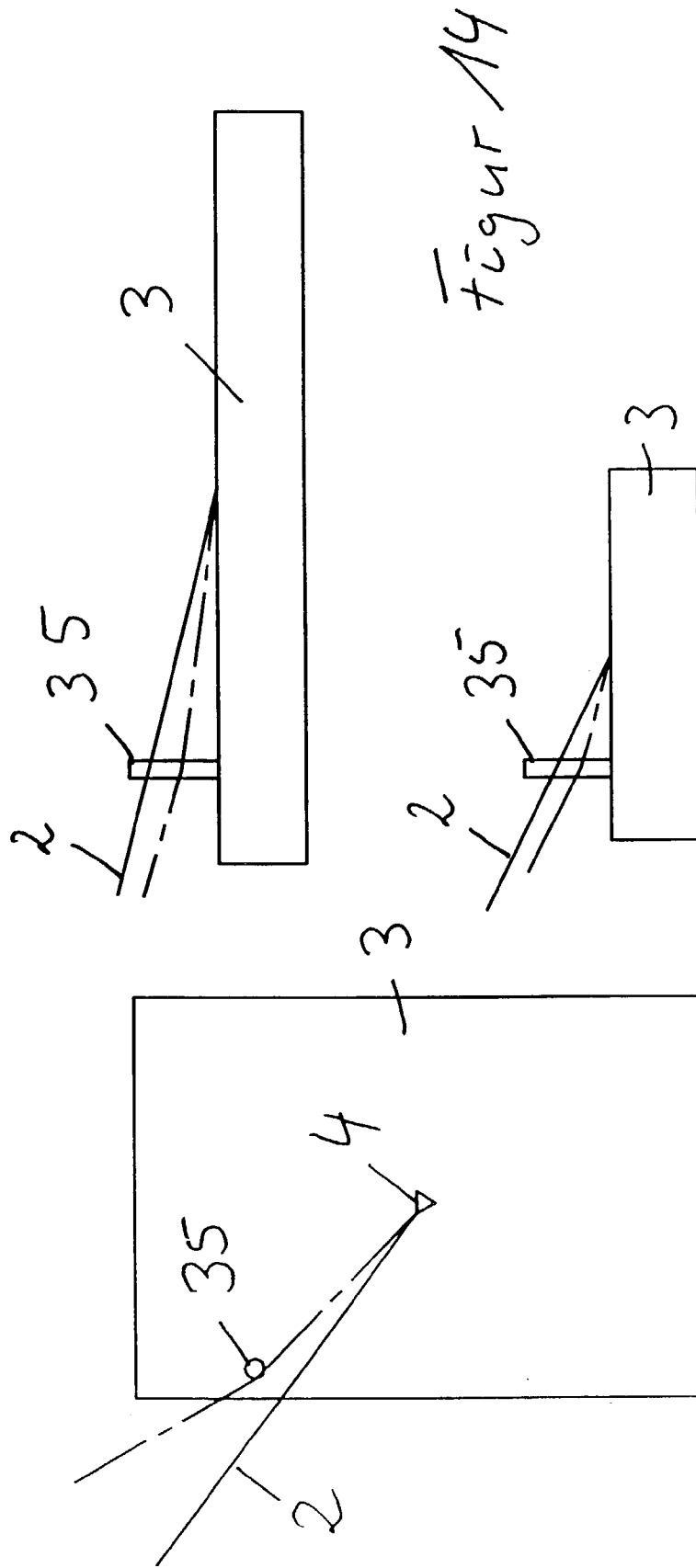

Figure 14

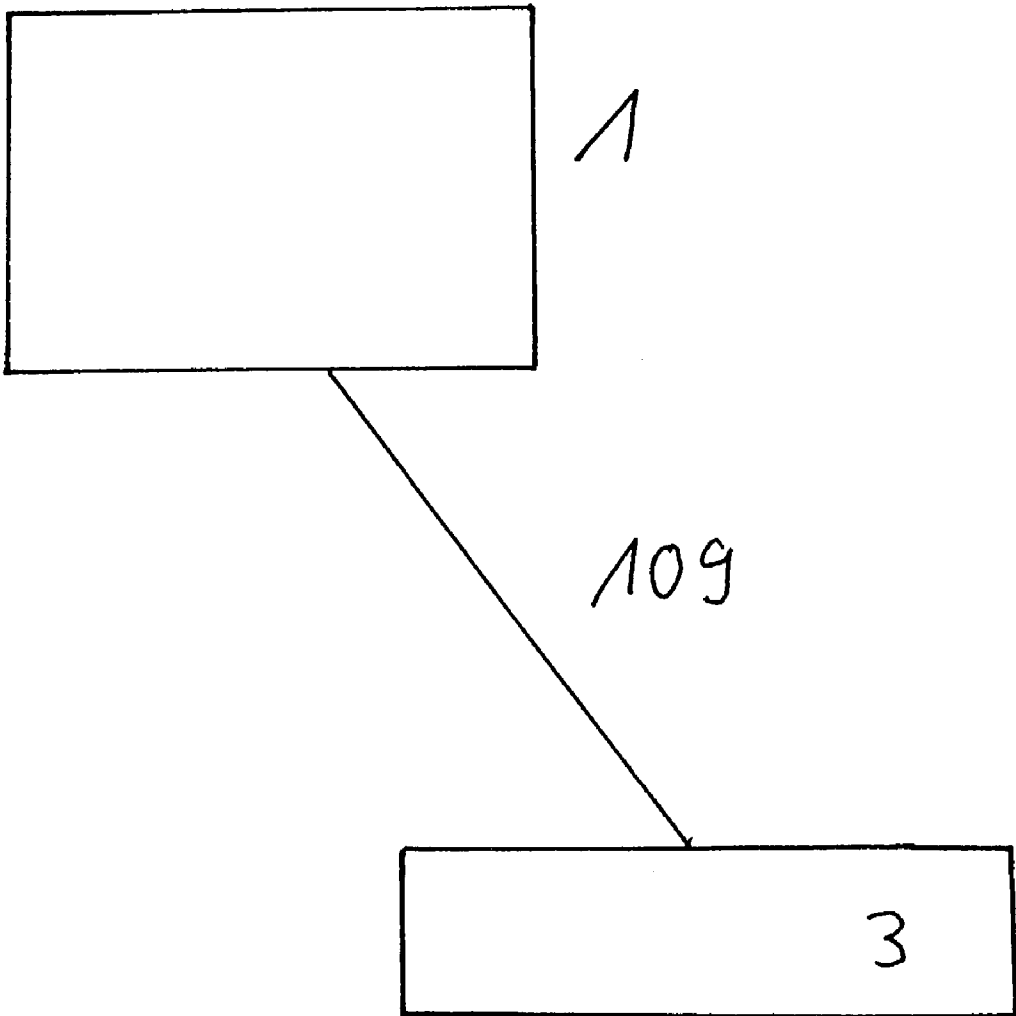

Figure 15

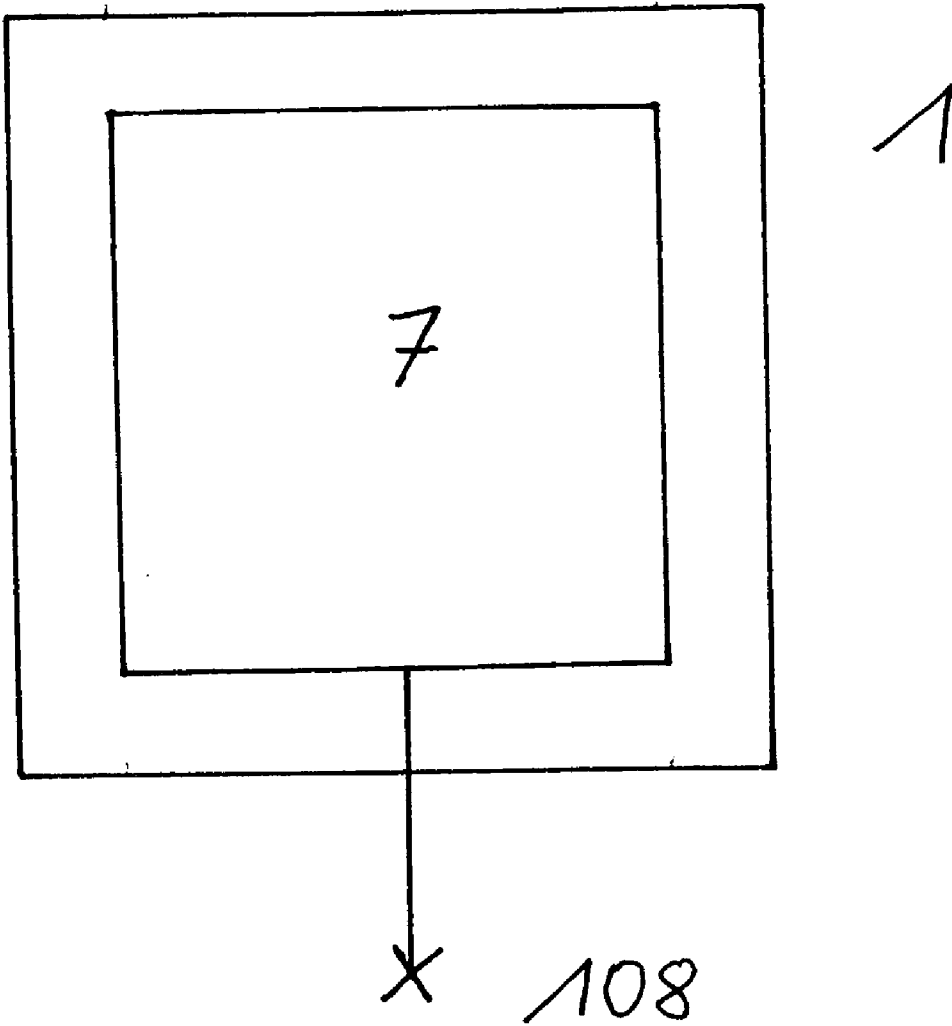

Figure 16

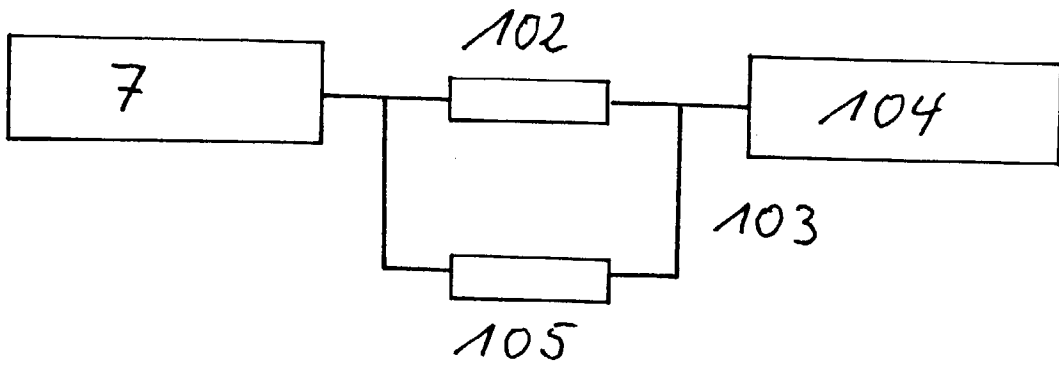

Figure 17

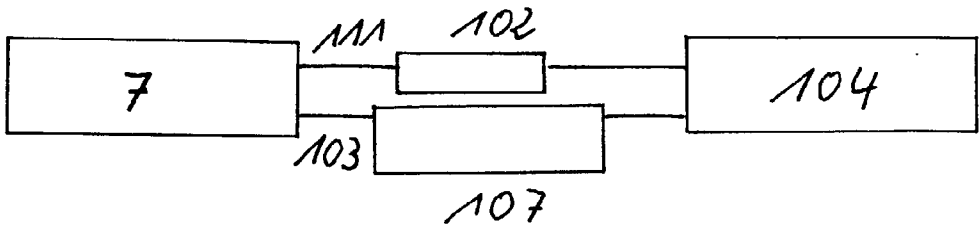

Figure 18

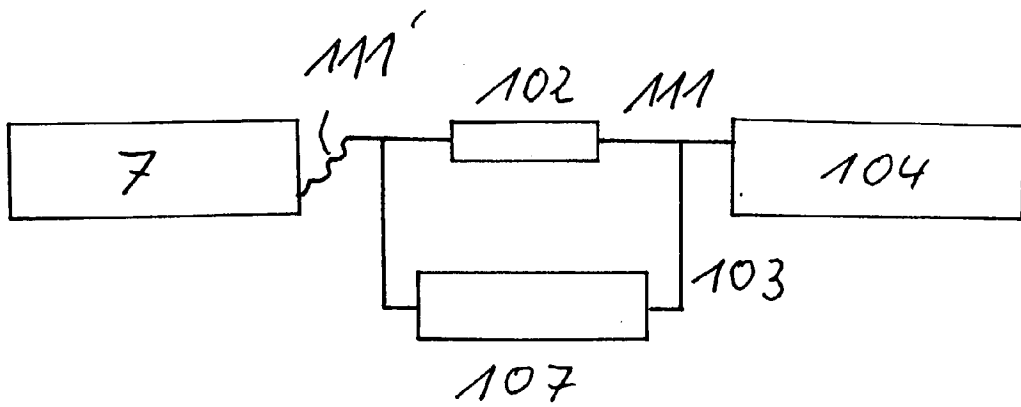

Figure 19

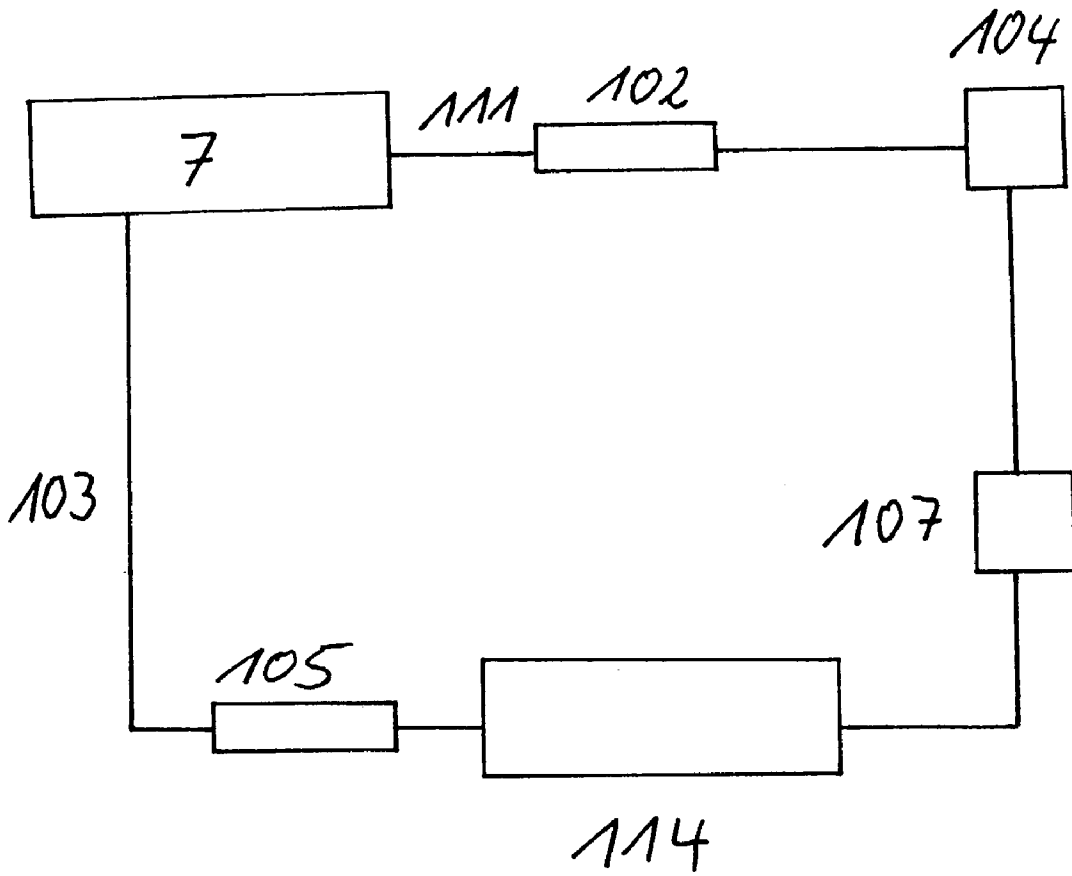

Figure 20

### WIND-PROPELLED WATERCRAFT

[0001] The invention relates to wind-propelled watercrafts in which at least one sheet element is held with at least one stay rope on a body of the watercraft, in particular a hull. The invention can be employed more particularly with sail ships and other watercrafts as well solely or in combination with additional conventional drives.

[0002] Heretofore, it is usual for the propulsion of watercrafts and other vehicles as well to take advantage of wind power to use one or a plurality of sails made of textile materials which are stabilized at least on one mast, and also in addition with so-called booms or yards. Such sails will be aligned in accordance with the wind direction or the desired direction of motion, and utilize at least one component of the wind power which as a rule merely provides one portion of the total wind power for generating propulsion.

[0003] With this form, however, turning moments are also acting in the longitudinal axis in which the mast(s) is (are) arranged as well which more or less cause an oblique position about the longitudinal axis of a hull and body of the watercraft, respectively. To actively oppose this effect leeboards and cost effective keel constructions, respectively are employed with sail ships and sailing boats, respectively according to the size of the used sail areas. Since limits are set for this, however, the direction of motion and wind direction can be utilized in an optimized manner to each other only to some extent, and the ship can be adequately steered such that frequently crossing is required with unfavourable wind directions which of course results in an extension of the duration of travel toward a particular destination.

[0004] With high wind velocities in particular the mast and masts, respectively is (are) providing a weakest point, and in the case that the mast and masts, respectively is (are) breaking sailing boats and sail ships are nearly incapable of manoeuvring and exposed to the rigours of weather and water without any resistance because of the failed propulsion such that a high potential of danger is given to the ship's crew.

[0005] For avoiding said dangers with high wind velocities it can be required to reduce at least one portion of the sail area by reefing sail in order to decrease the forces and turning moments acting on the masts of the ship. Thereby, of course the driving speed of such a boat and ship, respectively is reducing.

[0006] Therefore, it is an object of the invention to provide wind-propelled watercrafts by means of which the wind forces can be better used for the propulsion, and the turning moments acting about the longitudinal axis on the body of the watercraft and hull, respectively can be decreased.

[0007] In accordance with the invention this object is solved with the features of claim 1. Advantageous embodiments and improvements of the invention can be implemented with the features mentioned in the subordinate claims.

[0008] The watercraft according to the invention uses at least a sheet element which is formed similar to a conventional sail or a sufficiently well-known kite as well to increase the propulsion due to the action of wind force, and to largely reduce the tilting moments already mentioned.

Such a sheet element which should have a small mass, if possible, is held with at least one stay rope in close proximity to the body of the watercraft wherein the stay rope is attached to the sheet element on at least three points spaced apart from each other to allow the sheet element to be deflected and aligned in the vertical and horizontal directions in order to enable an optimum alignment of the sheet element according to the desired direction of motion under consideration of the respective wind direction.

[0009] This can be taking things so far that by means of a stay rope, control the sheet element will be aligned and brought into the wind such that it is allowed to be moved in the vertical direction upwardly and downwardly, respectively within wind layers having higher wind velocities.

[0010] Such an element and a plurality of elements as well, wherein a plurality of sheet elements are preferably connected to each other, can be made of a lightweight sheet material. Favourably, flexible materials may also be employed for such sheet elements which deform themselves due to the wind force then, and equivalently increase the drag factor (EW) such that the component of force usable for the propulsion is also increased.

[0011] Compressed gas containing chambers can be arranged, formed and also secured, respectively on the one sheet element and a plurality of sheet elements, respectively for increasing the stability as well and lift, as the case may be, for such a sheet element. Such a compressed gas containing chamber which is formed and arranged, respectively in close proximity to the sheet element, and in which compressed gas is contained results in an increase of the stability of such a sheet element. Such compressed gas containing chambers can also achieve a supporting function similar to rigid frame constructions with a smaller mass for sheet elements. By means of one or a plurality of compressed gas containing chamber the form and shape of the sheet element can be defined.

[0012] On the compressed gas containing chambers fittings with valves can be provided which allow charging and discharging the compressed gas containing chambers, respectively.

[0013] It is more especially advantageous to charge the compressed gas containing chambers with gas having a lower density than air such that a lifting force component can be obtained for the sheet elements. Appropriate charging gases for example are helium, but hydrogen as well. With a sufficiently great volume and sufficient charging with such a gas having a relatively lower density it can be achieved that the lifting force is at least greater than or equal to the weight of the sheet element. However, it should also be greater than or equal to the proportional weight of the stay rope(s), if possible. In this case, the sheet element is freely floating in the atmospheric air, and it is allowed to be significantly easier manoeuvred and aligned relative to the prevailing wind direction. In addition, thus it is prevented from dropping on the ground and water surface, respectively and then an expense action is required to bring the sheet element into the wind again.

[0014] However, similar to a conventional captive balloon, the compressed gas containing chamber(s) can also be charged with a gas of lower density, and such a sheet element is allowed to be suspended thereon. In case that a

two-dimensional element made of a flexible material has been used it is favourable to use at least two of such compressed gas containing chambers in the form of a captive balloon.

[0015] However, the compressed gas containing chambers can also be provided with apertures by means of which they can be charged with air due to a dynamic pressure when the sheet element is directed into the wind.

[0016] For enabling the first already mentioned alignment of such sheet elements both in the vertical direction and horizontal direction it is favourable to vary the length of the stay ropes each used between the sheet element and body of the watercraft and hull, respectively. On that occasion, each stay rope can be lengthened and also shortened, respectively one by one individually. It is also possible, however, for such two stay ropes each which are arranged on the sheet element in horizontal and vertical planes, respectively, to be lengthened and shortened, respectively with the same length in the opposite direction.

[0017] By simultaneously uniform lengthening or shortening all stay ropes the sheet element can be brought into the wind or can be hauled in.

[0018] The elements used to vary the length of the stay ropes are allowed to be pulleys, for example, which the respective stay rope can be wound up on and unwound therefrom, respectively. Such pulleys can be constructed such as the elements which in the sailor's language are designated as "winches".

[0019] The propulsion can be manually carried out in a controlled manner by means of electric motors and back-gear motors, respectively in which the control of the sheet element, thus shortening and also lengthening the stay ropes can occur under consideration of the measured wind direction, the desired direction of motion and/or else as the case may be under consideration of the tensile forces measured on the individual stay ropes by means of an electronic control.

[0020] In particular, for each avoiding and reducing the turning moments (tilting moments) acting about the longitudinal axis it is advantageous to vary the point of application of force of the stay ropes on the body of the watercraft and hull, respectively under consideration of the respective wind direction and direction of motion. This applies independently to whether with respect to a plurality of stay ropes these are secured to the body of the watercraft in close proximity to each other or whether a common virtual point of application of force results from the force vectors of these stay ropes.

[0021] With this, various solutions are possible.

[0022] Thus, on the one hand it is possible to adequately adapt the point of application of force of the stay ropes on the body of the watercraft by means of a guide. In the most simple case such a guide can be a hoop being orthogonally aligned with the longitudinal axis of the body of the watercraft which the stay rope(s) is (are) lead about such that according to the alignment of the sheet element with respect to the longitudinal axis of the point of application of force will be automatically displaced. It is more especially advantageous for this transversal hoop to be curvedly formed such that the convex contour of such a hoop is facing upwardly

and in the direction of the front of the body of the watercraft (direction of hoop) respectively and obliquely forwardly.

[0023] Such a solution can be additionally improved when such a transversal guide is received within two guides aligned in parallel with the longitudinal axis of the body of the watercraft, and is allowed to be displaced by means of such guides along the longitudinal axis of the body of the watercraft.

[0024] Another alternative to vary the point of application of force of the stay ropes is to provide it excentrically on a rotary table which is rotatable with its centre about a vertically aligned rotational axis such that the point of application of force with respect to the longitudinal axis of the body of the watercraft is allowed to be automatically varied in its position due to the excentric arrangement and the turning moments correspondingly acting. However, such a variation of position can also be implemented in a controlled manner with an equivalent rotary drive for the rotary table.

[0025] A third alternative of varying the point of application of force for the stay rope(s) is in the use of a lever shaped jib boom which on one side comprises a link by means of which the lever shaped jib boom is attached, e.g., to the longitudinal axis of the body of the watercraft. Then, the stay rope(s) are secured in a distance preferred at the end of this jib boom such that during pivoting the jib boom about the link it can be achieved a variation of the position of the force application point of the stay rope(s) with respect to the longitudinal axis of the body of the watercraft. Ball and socket joints and universal joints, for example, are suitable as a link which can also be secured inside a guide which is aligned at right angles to the longitudinal axis.

[0026] The point of application of force can also be varied with respect to the so-called lateral centre of pressure, and selectively adjusted such as still to be described in the following. With the lateral centre of pressure it deals with the area related centre of inertia of the projected area on the longitudinal axis of the watercraft. It is allowed to coincide with the mean transversal axis, and the transversal axis can be located close to the lateral centre of pressure, respectively such that this as well can be used as reference for the point of application of force in a simplified manner.

[0027] By means of selectively influencing the position of the point of application of force with respect to the lateral centre of pressure it is also allowed for the direction of motion (course) of the watercraft to be influenced. Thus, with a position of the point of application of force in front of the lateral centre of pressure the watercraft can be turned into the direction of the side sheltered from the wind (lee side) and into the direction to the side facing towards the wind (weather side) during positioning the point of application of force in the opposite direction, thus behind the lateral centre of pressure (always viewed in the direction of motion).

[0028] By influencing the position of the point of application of force of the sheet element orthogonally to the longitudinal axis and direction of motion, respectively the heeling can be selectively influenced in a completely compensated manner. Thus, in certain cases even a negative heeling can be met if the point of application of force has been displaced quite far in the direction of the side sheltered from the wind, for example.

[0029] In addition to the already mentioned elements for varying the effective lengths of the stay rope(s) additional deflection pulleys can be disposed between the point of application of force and the sheet elements. The stay ropes can be deflected through these deflection pulleys which is favourably effecting during the variation of position of the point of application of force, on the one hand. These deflection pulleys can also be displaced, on the other hand, whereby a unique and additional variation of length of a plurality of stay ropes can be achieved in a relatively simple manner and without any required actuating forces.

[0030] For a sail-shaped and kite-shaped sheet element, respectively which has been stretched in a two-dimensional manner using the already mentioned compressed gas containing chambers if possible, the most different geometric forms can be employed wherein optimizing the shapes of the sheet elements for the respective application can also be carried out under consideration of the design of the body of the watercraft used.

[0031] For a sufficient manoeuvrability of the sheet element it is advantageous to use at least three stay ropes being variable in its effective length independently from each other, which are attached to the body of the watercraft and to the sheet element then. Mounting on the sheet element is achieved such that the three mounting points of the stay ropes are spanning a triangle, and thus with lengthening and shortening, respectively the effective lengths of the three stay ropes the sheet element can be moved both in horizontal and vertical directions as well by means of the attacking wind force, and in addition the angle of attack is variable with respect to the prevailing wind direction.

[0032] It is more favourably to use four stay ropes which provide the connection between the sheet element and the body of the watercraft. On that occasion, the four stay ropes are attached to the sheet element such that the mounting points are spanning a square, if possible, wherein each two mounting points are in a common horizontal plane, and the other two mounting points are in a vertical plane. For manoeuvring the sheet element at least lengthening and shortening, respectively of a stay rope is required. However, the stay ropes which mounting points are on the sheet element in a plane can also be lengthened and shortened with the same length if possible in opposite direction each. If this modification will be selected, the actuation power each required can be correspondingly reduced such that manual actuating is readily possible.

[0033] With the invention the keel constructions being common for watercrafts heretofore, first are allowed to be smaller dimensioned and even more substituted by more cost effectively leeboards since the turning moments acting about the longitudinal axis will be significantly reduced.

[0034] Application in average situations is also possible, e.g., if with a conventional sail ship or sailing boat a mast has been broken and a wind propulsion according to the invention which is onboard can be rapidly and simply employed and provide the propulsion and manoeuvrability.

[0035] In additions it is advantageous to provide at least one hydrodynamically effective element, which can also be designated with the term "hydrofoil", on the body of the watercraft. On that occasion, such an element is located beneath the floating line on the body of the watercraft and allows stabilizing the watercraft during the progressive movement.

[0036] It is more especially advantageous that such a hydrodynamically effective element can be pivoted about an axis such that a lift force or a depression force can be adjusted for the watercraft.

[0037] However, these hydrodynamically effective elements should be arranged such that symmetrical force relations occur with respect to the longitudinal axis of the watercraft. Thus, for example, two such elements can be arranged in the same level on the two outer sides of the body of the watercraft.

[0038] Favourably, the pivoting angle of the hydrodynamically effective elements can also be adjusted depending on the vehicle speed and/or tensile force of the sheet element. In particular, during immediately occurring gusts of wind, thus it can be ensured that the body of the watercraft will be carried in the water also during extreme situations. With this, the pivoting angle of the hydrodynamically effective elements can be adjusted by a mechanical coupling by means of the tensile force acting on the stay ropes or point of application of force.

[0039] These elements are allowed to be formed similar to wings and either aligned horizontally or in an angle slightly inclined toward the horizontal.

[0040] The aerodynamic properties of the sheet element can be influenced by effecting the three-dimensional form which can be achieved by means of the stay ropes, and if the case may of additional stay ropes. In addition, supplementary aerodynamically effective elements can be attached to the sheet element. These aerodynamically effective elements are allowed to be pivotally secured on the sheet element and formed in a flap shape, for example, such that being more or less put upright they cause lift or side forces on the sheet element effected by the correspondingly increased flow resistance against the attacking wind according to the adjusted angle and the corresponding arrangement, and thus allowing for the position of the sheet element to be manipulated with respect to the body of the watercraft and the wind direction. The adjustment of the pivoting angle of these aerodynamically effective elements can be achieved by means of equivalent ropes as well, for example, which are guided toward the body of the watercraft.

[0041] It can also be of advantage if airflow breakaway elements (winglets) are provided on the outer edges of the sheet element which are allowed to cause an improvement of the aerodynamics as well.

[0042] To avoid situations of danger additional elements protecting from overload can be used. These elements ensure that with exceeding a predetermined maximum tensile force on the one or a plurality of stay ropes this force cannot attack on the body of the watercraft in full size. A possibility to oppose these overload conditions is in that to provide the stay ropes with a spring, a damper or a spring damping system wherein the spring and damper characteristics should be adjusted such that the equivalent spring or damping forces become effective until exceeding the threshold already mentioned, and for example a tension spring having a degressive spring characteristic should be selected such that the correlative tensile forces of such an element protecting from overload can be reduced again.

[0043] Another alternative for an element protecting from overload is in the use of sliding clutches which are provided at winches, for example, to influence the length of the stay ropes as the case may be.

[0044] Another advantageous aspect of the watercraft according to the invention can be equipped with a manipulable leeboard. Such a leeboard is allowed to be reciprocated in the vertical direction such that the effective area can be adjusted as the occurring heeling on the vehicle according to the invention can be completely, however, at least largely compensated.

[0045] However, such a leeboard can also be deflected with respect to the longitudinal axis of the body of the watercraft such that it is allowed to completely take over or support the function of a conventional rudder. In addition, with such a leeboard it is allowed to go higher by the wind (more height running).

[0046] To increase the safety at least one sensor string can be attached to the sheet element which is guided therefrom to the body of the watercraft. By means of these sensor strings with touching them the propulsion of the watercraft can be influenced, and such propulsion can be drastically reduced by the correlative influence of the aerodynamically effective surfaces and shape of the sheet element in a very short time. Preferably, two sensor strings can be attached to the outer edges of the sheet element.

[0047] Controlling a watercraft according to the invention can be facilitated by different ways and completely automated with adequate expense as well.

[0048] Thus, measured values detected with various sensors can be processed in control electronics, and at least the position of the sheet element can be influenced with respect to the desired direction of motion and wind direction with this control electronics.

[0049] However, controlling a vehicle according to the invention, can also be influenced purely mechanically in a relatively simple manner with sling elements for stay ropes which are provided on the body of the watercraft.

[0050] With these sling elements for stay ropes which are arranged on the body of the watercraft between the respective mounting point of the corresponding stay rope and the sheet element, influencing the position of the sheet element can be achieved. In the most simple case a sling element for stay ropes is allowed to be a vertically aligned rod attached to the body of the watercraft which the laterally drifting stay rope abuts against during equivalent movement of the sheet body which results in a relatively shortening of the stay rope which prevents a further movement of the sheet element into the direction which is not desired.

[0051] However, a sling element for stay ropes can also be designed in the form of a hoop which is attached to the body of the watercraft. The respective stay rope is guided through this hoop such that an abutting limit is provided on both sides in the horizontal direction and upwardly in the vertical direction.

[0052] The sheet element for a watercraft according to the invention is allowed to comprise at least one compressed gas containing chamber. The compressed gas containing chamber can be a part of the sheet element or be connected with the sheet element. Such a compressed gas containing cham-

ber should be able to be charged from a gas accumulator tank in which compressed gas being preferably helium is contained via a first conduit which is connected and can be connected to the compressed gas containing chamber, respectively. On that occasion, a defined gas volume is to be filled in into the compressed gas containing chamber which is sufficient to effect a lifting force for the complete sheet element which should be greater than or equal to the component of the gravitational force of the sheet element.

[0053] The connection between the compressed gas accumulator which can be a conventional gas bottle, and the compressed gas containing chamber on the sheet element can be achieved by a valve and can be disconnected therefrom again. Then, the valve can be arranged in close proximity on the outlet of the compressed gas accumulator but also in the first conduit, and can be manually opened and closed in a most simple manner.

[0054] However, a valve which automatically closes depending on the internal pressure in the compressed gas containing chamber can also be employed with reaching a predetermined internal pressure.

[0055] For recirculating gas from the compressed gas containing-chamber at least a second conduit should be present which in an alternative is passing in parallel to the first conduit already mentioned, and which can also be connected to the at least one compressed gas containing chamber wherein this second conduit is allowed to lead into a second compressed gas accumulator or into a second port of that one compressed gas accumulator connected to the compressed gas containing chamber as well.

[0056] However, the second conduit has not to be absolutely connected in close proximity with a compressed gas containing chamber, but it is also allowed to be connected to the first conduit wherein the port to the first conduit can be achieved through a so-called T-piece.

[0057] The second conduit can also represent a by-pass around the valve already mentioned to the first conduit, however, wherein in this case the gas recirculated from the compressed gas containing chamber is to be carried into the one compressed gas accumulator.

[0058] As a rule, at least in such cases in which the recirculated gas is to be carried into the gas accumulator which has also been used for charging the compressed gas containing chamber, in the second conduit a compressor can be disposed the induction side of which is connected to the portion of the second conduit towards the compressed gas containing chamber, and the delivery side of which is connected to the portion of the second conduit which communicates with the gas accumulator.

[0059] Compressors in the most different well-known forms are possible, however, wherein on the delivery side a gas pressure should be available by means of which it is ensured that the compressed gas accumulator can be charged again with the recirculated gas.

[0060] In the most simple cases manually actuated compressors such as hand pumps or piston compressors can be employed.

[0061] If two gas accumulators are used, then the second gas accumulator into which the gas from the compressed gas containing chamber is again recirculated can be differently

dimensioned such that inside thereof a relatively low internal pressure occurs with the recirculated gas wherein the already mentioned compressor can be abandoned as the case may be.

[0062] The recirculated gas temporarily stored in the second compressed gas accumulator is thus allowed to be recirculated from this second compressed gas accumulator into a first compressed gas accumulator and to be compressed higher at any times by means of an equivalent compressor.

[0063] The first conduit already mentioned can be temporarily connected to the compressed gas containing chamber for charging and recirculating the gas wherein in this case a lockable connecting branch should be provided on such a compressed gas containing chamber.

[0064] As the required internal pressures in the compressed gas containing chamber are relatively low, however, it is also possible to stationarily connect a relatively weak dimensioned first conduit having a low mass to the compressed gas containing chamber such that the first conduit with a sufficient length has not to be separated from the sheet element during the progressive movement of the watercraft.

[0065] The first conduit should be made of flexible material not only in this case such that handling is facilitated.

[0066] However, the first conduit connecting the compressed gas containing chamber and a compressed gas accumulator can also be guided as a by-pass around a compressor wherein the gas stream can be guided through this first conduit or the compressor by means of at least one two-way valve. The second conduit can be formed in this case by the compressor with its two ports. The first conduit can be guided through the compressor housing.

[0067] The compressed gas accumulator utilized at least for charging the one and also a plurality of compressed gas containing chambers, respectively should have an internal pressure of gas before and during charging which is greater than or equal to the required internal pressure in the pressure chamber and in the pressure chambers, respectively.

[0068] All the components required for charging and recirculating the gas are allowed to be carried with the wind-propelled watercraft such that replenishing the compressed gas containing chamber is also possible during the further movement. At least one of the compressed gas accumulators should be able for this to be attached to the vehicle wherein the attachment should be formed such that the equivalent compressed gas accumulator can be carried separately of the vehicle to a tank installation for replenishing with gas.

[0069] In the following, the invention shall be explained in more detail according to embodiments in which

[0070] FIG. 1 shows an embodiment of a sheet element which can be employed on a watercraft according to the invention;

[0071] FIG. 2 shows another embodiment of a sheet element having a kite shape;

[0072] FIG. 3 illustrates a top view upon a body of the watercraft with an embodiment for a wind propulsion according to the invention;

[0073] FIG. 3a illustrates an enlarged section X from FIG. 3;

[0074] FIG. 3b shows a jib boom which can be employed with the embodiment according to FIG. 3;

[0075] FIG. 4 illustrates a top view of another embodiment with a body of the watercraft;

[0076] FIG. 4a shows the enlarged section Y from FIG. 4;

[0077] FIG. 4b shows an embodiment of an element suitable for varying the length of stay ropes;

[0078] FIG. 5 shows a top view of another embodiment for carrying out guides on a body of the watercraft;

[0079] FIG. 5a shows a sectional view along A-A from FIG. 5;

[0080] FIG. 5b illustrates the section Z as an enlargement from FIG. 5a;

[0081] FIG. 6 shows another embodiment of wind propulsion in a top view;

[0082] FIG. 7 shows a top view upon a body of the watercraft having a jib boom for varying the point of application of force;

[0083] FIG. 7a shows a front view upon an embodiment according to FIG. 7;

[0084] FIG. 7b shows the enlargement of the sections W and W' from FIG. 7a;

[0085] FIG. 8 shows a top view upon another embodiment of a wind propulsion; FIG. 8a shows a side view of FIG. 8;

[0086] FIG. 9 shows a diagrammatic view of an embodiment of a wind propulsion on a sailing boat;

[0087] FIG. 10 shows a top view upon a diagrammatically illustrated body of the watercraft;

[0088] FIG. 11 shows three embodiments of modification for sheet elements and the possible alignment thereof toward the wind;

[0089] FIG. 12 shows three embodiments for adjusted forms of a sheet element under consideration of the wind force;

[0090] FIG. 13 shows a diagrammatic view of a sheet element having aerodynamically effective elements;

[0091] FIG. 14 shows a diagrammatic view of a sling element for stay ropes disposed on a body of the watercraft in three views;

[0092] FIG. 15 shows diagrammatically a body of the watercraft which is connected to a sheet element by means of a stay rope;

[0093] FIG. 16 shows an embodiment of a sheet element comprising a compressed gas containing chamber and a connecting branch;

[0094] FIG. 17 shows the structure of an embodiment of a gas supply and recirculation according to the invention in a diagrammatic form;

[0095] FIG. 18 shows a second embodiment of a gas supply and recirculation according to the invention;

[0096] FIG. 19 shows a third embodiment of a gas supply and recirculation to be used according to the invention;

[0097] FIG. 20 shows an embodiment of a gas supply and recirculation to be used according to the invention with two gas accumulators.

[0098] In the FIGS. 1 and 2 are shown two possible embodiments for sheet elements 1 as can be employed in the sail and kite shapes as well, respectively for a wind propulsion according to the invention.

[0099] With the embodiment according to FIG. 1 the sheet element 1 is attached with four stay ropes 2 to the not illustrated body 3 of the watercraft wherein the length of the four stay ropes 2 can be varied each individually, if possible in order to move the sheet element 1 in the most different directions and align in accordance with the desired direction of motion with a present wind direction.

[0100] In this embodiment the sheet element 1 is made of a flexible material, for example a film and a textile fabric, respectively which at least are gasproof. The at least two-layered sheet element 1 sealed at the edges defines a compressed gas containing chamber 7 in the complete interior thereof which, e.g., is filled with helium. Charging the compressed gas containing chamber 7 is achieved under consideration of the chamber volume and the masses of the sheet element 1, the mass thereof and the shared mass of the stay ropes 1 in so far that a lifting force can be generated which is greater than the corresponding gravitational force such that the sheet element 1 will be readily held in the atmosphere as permitted by the respective length of the stay ropes 2.

[0101] The sheet element 1 shown herein approximately corresponds to the contour and cross-sectional geometry, respectively of a conventional wing of an aircraft which makes effecting a dynamic lift component caused by flow conditions on the element 1 in addition to the static lift. By adequate adjusting the lengths of the four stay ropes 2 it is allowed to be aligned into the wind such that, if possible, a great air resistance is achieved with a great effective acting surface, if possible which can be opposed to the wind.

[0102] However, more than four stay ropes 2 as illustrated herein can also be employed wherein this may be advantageous with large surface dimensioned sheet elements 1.

[0103] The embodiment of a sheet element 1 shown in FIG. 2 is similar to the design of conventional kites, and it is immediately attached to the body 3 of the watercraft also not shown with merely one stay rope 2. The stay rope 2 runs starting from a hitch 20 in three individual lines which are attached to edge points of the kite-shaped sheet element 1, wherein the sheet element 1 comprises a frame construction 12 which preferably may be made of a lightweight and solid material. On that occasion, it is allowed to concern with carbon fiber reinforced plastics in tube or rod shapes which adequately stabilize a textile fabric and keep it in form.

[0104] The variation of the respective length of one and a plurality of stay rope(s) 2 as well respectively can be implemented in various manner which it shall be better explained by way of example with the subsequent description of another figures.

[0105] Thus, FIG. 3 being a top view upon a diagrammatically illustrated body 3 of the watercraft shows a

possibility with four stay ropes 2 in all which each can be individually varied with elements 5 in its effective length between the body 3 of the watercraft and the sheet element 1 not shown.

[0106] From the illustrations shown in FIGS. 3, 3a and 3b several variations can be derived by a corresponding explanation.

[0107] Thus, the elements 5 which are commonly formed as pulleys which the respective stay ropes 2 can be wound up on and unwound therefrom, respectively are allowed to be anchored on the body 3 of the watercraft. From these pulleys 5 the four stay ropes 2 are guided over a deflection pulley 6' which herein is modified as a so-called four-pulley block or with two double blocks, over further four deflection pulleys 6 toward a deflection element which represents the actual point 4 of application of force of the stay ropes 2 on the body 3 of the watercraft, and therefrom to the sheet element 1 not shown.

[0108] On that occasion, the force application point 4 and the sheet element 1 are selectively drifting caused either by lengthening and shortening, respectively the individual stay ropes 1 due to winding up and unwinding, respectively on the pulleys 5. It is also allowed to drift in that the double block 6' as deflection pulleys for the stay ropes 2 will be varied its position. In particular with the description of the FIGS. 3a and 3b it shall be still referred back to possibilities, for example, on how this can be achieved.

[0109] In FIG. 3a the detail X from FIG. 3 is shown as an enlargement.

[0110] Then, several arrows have been drawn especially on the deflection pulley system 6' herein used as a four-pulley block to indicate the possibilities for influencing the position of the point 4 of force application. Thus, it is possible to provide shifting in parallel or orthogonally to the longitudinal axis of the body 3 of the watercraft as well as a pitch circle diameter shifting as indicated with the correspondingly formed double arrow. The latter can be achieved with an arrangement on a rotary table 11 which can be distorted about a symmetrically arranged rotational axis. Then, the deflection system 6' is eccentrically disposed on the rotary table 11 and moves on a circle path during rotating the rotary table.

[0111] In another variant the use of a lever arm and jib boom 10, respectively secured to a joint 16 on the body 3 of the watercraft which the deflection system 6' is attached to as two double blocks. The jib boom 10 can be automatically adequately pivoted, selectively manually but also mechanically at the upper end due to the deflection of the sheet element 1 such that the deflection point for the stay ropes 2, which is predetermined by the deflection system 6', is drifting therewith according to the movement of the jib boom 10.

[0112] In particular, in FIG. 3a on the bottom of the body 3 of the watercraft anchored eyes can be seen which the four another deflection pulleys 6 are attached to, which one stay rope 2 each is further deflected on.

[0113] With the embodiment of a control shown in FIGS. 4, 4a and 4b for the wind propulsion according to the invention four stay ropes 2 have been used again which are guided on a sheet element 1 and attached thereto which can

be formed such as according to **FIG. 1**. Each individual stay rope **2** is guided through a separate deflection pulley **6** toward an element **5** by means of which the respective length of the stay rope **2** can be varied. Such an element **5** can be formed as indicated with **FIG. 4b**, for example, as a conventional winch as it is used on sailing boats and sail ships, respectively, and is allowed to comprise a free-wheel and brake. Additionally, a crank can be joined by means of which the respective stay rope can be wound up and unwound.

[0114] The force application point **4** for the four stay ropes on the body **3** of the watercraft can be varied by means of a deflection system, for example a pulley system which in the sailor's language is designated as a four-pulley block, and the position thereof by varying the length of the four stay ropes **2** under consideration of the desired direction of motion and the present wind direction.

[0115] The enlarged illustration of the section **Y** in **FIG. 4a** is intimating herein that eyes **13** are anchored on the bottom of the body **3** of the watercraft as well, and which serve for supporting the deflection pulleys **6**.

[0116] With the embodiments according to **FIGS. 5, 5a** and **5b** guides **8** and **9** are employed to vary the position of the force application point **4** with respect to the longitudinal and transversal axes of the body **3** of the watercraft.

[0117] Thus, two longitudinal guides **9** which are aligned in parallel to the longitudinal axis of the body **3** of the watercraft are disposed at the edges of the body **3** of the watercraft. In these longitudinal guides **9** a transversal guide **8** is held and guided such that it can be displaced over the total length of the body **3** of the watercraft, as required.

[0118] However, only one of the guides **8** or **9** can be employed as well.

[0119] As can be seen in the sectional view **5a** along the section **A-A**, however one or a plurality of stay ropes **2** as well are guided to the deflection pulleys **6** disposed on a guide element **14** guided on the transversal guide **8** or in close proximity toward this guide element **14** with the deflection pulleys **6** abandoned, and are attached thereto.

[0120] As can be better seen in the enlarged sectional view **Z** in **FIG. 5b** the guide element **14** can be reciprocated along the transversal guide **8** which it is guided on in a form-fit manner and held as indicated with double arrow such that the force application point **4** can be varied orthogonally to the longitudinal axis of the body **3** of the watercraft by means of shifting the guide element **14**. If the transversal guide **8** now is displaced along the longitudinal guides **9** a further variation of the position of the force application point **4** can be obtained.

[0121] With the embodiment shown in **FIG. 6** relating to a possibility for varying the effective length of the stay ropes **2** between the body **3** of the watercraft and sheet element **1** not shown as well, a double lever **5** has been used which ends each a stay rope **2** is attached to. Then, the double lever arm **5** can be distorted about an axis **15** of rotation such that according to the distortion angle of the double lever **5** about the rotational axis the right and the left stay ropes **2**, respectively either can be lengthened or shortened. The stay ropes are guided to the sheet element **1** around one deflection pulley **6** each which can be formed here as a double block.

On that occasion, this deflection pulley system **6** is allowed to represent the force application point **4**.

[0122] With the embodiment shown in **FIGS. 7, 7a** and **7b** a jib boom **10**, which is attached to the body **3** of the watercraft with a joint **16**, is used for varying the position of the force application point **4** for the stay ropes.

[0123] The joint **16** is preferably a ball and socket joint and a universal joint, respectively by means of which the jib boom **10** can be pivoted into the most different directions.

[0124] The stay ropes **2** are slung to the opposite end of the jib boom **10** with respect to the joint **16** wherein the jib boom **16** is allowed to have a length which can protrude beyond the maximum extension of the body **3** of the watercraft. Thus, the tilting moment can be further reduced by more appropriately lever relations.

[0125] As indicated in **FIG. 7a** the jib boom **10** can be held and aligned with at least one and preferably two (in opposition to the illustration) rope systems in the form of sheets as such elements are commonly designated in the sailor's language.

[0126] In **FIG. 7b** sections **W** and **W** from **FIG. 7a** are shown to indicate the configuration of the joint **16** with its fixation on the body **3** of the watercraft and slinging the stay ropes **2** on the jib boom **10**.

[0127] With the embodiment shown in **FIGS. 8 and 8a** for a possibility to vary the length of stay ropes **2** in principle there are two alternatives for influencing the effective lengths of the individual stay ropes **2** which can be performed and used together, however individually as well.

[0128] Thus, each of the two stay ropes **2** herein are wound up on a pulley **5** as a "winch" and guided through a deflection pulley system herein comprising four, however at least two deflection pulleys **6**.

[0129] As can be appreciated from the top view according to **FIG. 8** at least two of the deflection pulleys **6** can be translationally displaced forth and back.

[0130] As can be clearly seen from the side view according to **FIG. 8a** these deflection pulleys **6** are guided in a form-fit manner and kept together with one pedal **19** each on a guide **18**. When the pedals **19** are translationally moved either forth and back along the guide **18** which is attached to the body **3** of the watercraft then the effective length of the respective stay rope **2** will be adequately shortened or lengthened.

[0131] In **FIG. 9** is shown a sailing boat with a hull as a body **3** of the watercraft having a leeboard **21** and a conventional rudder **22**. Four stay ropes **2** are slung on the body **3** of the watercraft and at the other ends attached to a sheet element **1** in the form of a textile sail. At the edge of this sail-shaped sheet element **1** an encircling compressed gas containing chamber **7** is formed which can also comprise a plurality of separated individual chambers in which compressed gas is contained. With such a compressed gas containing chamber **7** a frame and stabilization function for a flexible sheet element **1** is achieved. The stability can be further increased as indicated with additional rod-shaped elements and also by means of an adequate chamber design, respectively.

[0132] The length of the four stay ropes can be varied in a most different form for example with one of the already previously described systems.

[0133] In FIG. 10 is diagrammatically shown a top view upon a body 3 of the watercraft for an embodiment of the watercraft according to the invention. On that occasion, the hatched area which can extend over the total width of the body 3 of the watercraft and also beyond as the case may be, and which is arranged in the area of the drawn transversal axis of the body 3 of the watercraft herein represents the surface in which the point of application of force can be positioned by means of guides 8 and 9 as shown in FIGS. 5a and 5b in order to minimize the heeling and to be able to achieve an optimum driving speed. This area is allowed to be circular when a rotary table or a jib boom 10 are used.

[0134] The effects which can be achieved by adequately positioning the point of application of force are mentioned in the general part of the description.

[0135] In FIG. 11 three embodiments relating to the forms of modification of the sheet elements are illustrated wherein the individual cross-sections are discernible herein. With these embodiments the construction of the sheet elements 1 is based on the shapes known from wings of aircrafts, and sheet elements 1 thus formed are allowed to be aligned with respect to the wind as shown in FIG. 11 such that on these sheet elements 1 a lifting component is generated with the wind which can be used for the propulsion of the watercraft through the stay ropes 2 not shown herein. By means of the different modifications as shown in FIG. 11 different propulsion forces acting as a tensile force on the point of application of force can be implemented by the correspondingly varied flow relations.

[0136] If sheet elements 1 are used in the modification forms as shown in FIG. 11 the so-called Ca coefficient (lift coefficient of a profile) is of importance in addition to the Cd factor, and just the Ca coefficient should be great in these cases, and accordingly the drag factor should be kept small.

[0137] By influencing the three-dimensional form with the profile the position, aerodynamic properties and accordingly also the acting forces can be influenced with the correspondingly occurring Ca coefficient and Cd factor.

[0138] During the travel of the watercraft the shape of the sheet elements 1 can also be influenced by varying the internal pressure within the compressed gas containing chambers 7.

[0139] In FIG. 12 there are shown three further embodiments for adjusted shapes of a sheet element 1 which can be adjusted by varying the length of individual stay ropes 2 and by means of which differently great wind forces can be taken into account.

[0140] Thus, the shape shown above can be met with small up to mean wind forces to keep to aerodynamic relations by means of this shape, which a maximum propulsion can be achieved with.

[0141] With setting the shape of a sheet element 1 as shown in the mean illustration, the propulsion force can be reduced at greater wind forces, and with quite high wind forces such as occurring with gusts of wind, a variation of the shape of the sheet element 1 as shown in the bottom illustration of FIG. 12 results in that the propulsion force is

reduced toward 0, and accordingly a very low tensile force occurs on the point of application of force. Such a modification can also be adjusted in other situations of danger such as by means of the at least one sensor string already mentioned in the general part of the description.

[0142] FIG. 13 shows in a diagrammatic form a sheet element 1 having four aerodynamically effective pivotable elements 32 in all which can be pivoted individually or together such that they are allowed to act similar to flaps and horizontal stabilizers known from aircrafts in order to be able to be used for a selective motion of the sheet element 1 in the vertical and horizontal direction when a determined pivoting angle is adjusted with respect to the surface of the sheet element 1. To these elements 32, for example, adequate ropes can be attached by means of which the angle of attack can be adjusted. In the cases in which these elements 32 engage the remaining part of the sheet element 1 in a two-dimensional manner they are ineffective.

[0143] With these aerodynamically effective elements 32 the Ca/Cd ratio can be influenced as well to manipulate the propulsion in the each desired form.

[0144] With FIG. 14 the effect and function of sling elements 35 for stay ropes shall be explained in a diagrammatic form. On that occasion, merely one such element 35 which is present in a rod-shaped manner on the body 3 of the watercraft is shown with its effect and function for only one stay rope 2. A stay rope 2 is illustrated with the solid lines when the sheet element 1 is positioned into the wind such that the watercraft is on the desired course that means it is moved in the desired direction of motion. If the sheet element 1 is now drifting, however, the equivalent stay rope 2 is moving therewith and is touching the sling element 35 for stay ropes, and the drifting motion will be limited correspondingly which necessarily results in a motion of the sheet element 1 into the direction opposite thereto without requiring any engagement manually or by means of another steering possibility.

[0145] Of course, a plurality of such sling elements 35 for stay ropes can be present in the form not shown. These are also allowed to be employed in pairs for one stay rope 2 each to limit the drifting motion of the sheet element 1 in two directions.

[0146] However, sling elements 35 for stay ropes are also allowed to be formed in a bundle shaped manner as already mentioned in the general part of the description.

[0147] In FIG. 15 a wind-propelled vehicle 3 is shown in a very simplified manner which is connected to a sheet element 1 being similar to a kite through at least one stay rope 100 such that the wind forces attacking the sheet element 1 can be used for the propulsion of the body 3 of the watercraft.

[0148] In FIG. 16 a sheet element 1 is shown with a compressed gas containing chamber 7 which comprises a connecting branch 108. The connecting branch 108 can be connected to a conduit 111 which the compressed gas containing chamber 7 can be charged through with a gas which is preferably helium such that by means of the charged compressed gas containing chamber 7 a lift component can be achieved which is sufficient to balance the gravitational force acting upon the sheet element 1.

[0149] The connecting branch **108** is allowed to be designed in the form of a conventional quick acting closure, for example, which should be able to be locked after charging the compressed gas containing chamber **7** such that the first conduit **111** (not shown herein) can be released again from the connecting branch **108** after charging the compressed gas containing chamber **7**, and the connection will be provided again only if the gas is to be recirculated again from the compressed gas containing chamber **7**.

[0150] In FIG. 17 an embodiment is shown in a diagrammatic form how compressed gas can be directed from a compressed gas accumulator **104** into the compressed gas containing chamber **7** of the sheet element **1** after opening the valve **102** which is disposed in a first conduit **111**. On that occasion, the valve **105** disposed in the second conduit **103** which is put around the valve **102** in the form of a by-pass, is closed.

[0151] For recirculating the gas from the compressed gas containing chamber **7** into the compressed gas accumulator **104** the valve **102** will be closed, and the valve **105** in the second conduit **103** will be opened wherein preferably a force of expansion can be exerted upon the compressed gas containing chamber **7** at least to assist the recirculation of the gas from the compressed gas containing chamber **7** into the compressed gas accumulator **104**.

[0152] In FIG. 18 is shown another embodiment of gas supply and recirculation from a compressed gas accumulator **104** into a compressed gas containing chamber **107** and vice versa. Here, two conduits **111** and **103** are connected in parallel to each other to the compressed gas accumulator **104** and the compressed gas containing chamber **7**. The gas contained in a compressed form within the compressed gas accumulator **104** is allowed to pass into the compressed gas containing chamber **7** after opening the valve **102**, and can be temporarily stored there and used for the lift of the sheet element **1**.

[0153] When the compressed gas containing chamber **7** is to be discharged either the connection through the conduit **111** is separated wherein this can be achieved by closing the valve **102**, and simultaneously the compressor **107** which is connected with its induction side to the compressed gas containing chamber side is switched on and the gas can be pumped from the compressed gas containing chamber **7** into the compressed gas accumulator **104**.

[0154] The embodiment according to FIG. 19 is modified with respect to the embodiment according to FIG. 18 in that the conduit **103** is formed as a by-pass around the valve **102**. However, in the form not shown as already explained in the general part of the description the valve **102** and compressor **107** as well as the conduits **111** and **103** can be exchanged.

[0155] In FIG. 19 is also indicated that at least one area **111'** of the first conduit **111** can be formed in a flexible manner.

[0156] In FIG. 20 is shown an embodiment of a gas supply and recirculation device having two compressed gas accumulators **104** and **114**.

[0157] On that occasion, it deals with a compressed gas accumulator **104** with higher internal pressure which the compressed gas containing chamber can be charged from after opening the valve **102** in the first conduit **111**.

[0158] With the closed valve **102** and the opened valve **105** in the second conduit the gas which is adequately compressed in the compressed gas containing chamber **7** is allowed to be recirculated into the second compressed gas accumulator **114** and temporarily stored there with relatively low pressure, wherein the internal volume of the compressed gas accumulator **114** is preferably allowed to be relatively great with respect to that of the compressed gas accumulator **104**. From this compressed gas accumulator **114** the temporarily stored gas from the low pressure gas accumulator **114** into the compressed gas accumulator **104** can be subsequently compressed and replenished, at a suitable time after switching on the compressor **107** which is connected with its induction side to the compressed gas accumulator **104** and with its delivery side to the compressed gas accumulator **104**.

1. A wind-propelled watercraft having a sheet element which is held with at least one stay rope in close proximity to the body of the watercraft, and said stay rope(s) is (are) attached to at least three points spaced apart from each other on said sheet element (1),

characterized in that the point (4) of application of force of the stay rope(s) on the body (3) of the watercraft is variable depending on the wind direction and motion.

2. A watercraft according to claim 1,

characterized in that said sheet element (1) is made of a flexible material.

3. A watercraft according to claims 1 or 2,

characterized in that on said sheet element at least one compressed gas containing chamber (7) is formed and/or attached thereto.

4. A watercraft according to any one of claims 1 to 3,

characterized in that said compressed gas containing chamber(s) (7) is/are charged with compressed gas having a density which is lower than air.

5. A watercraft according to any one of claims 1 to 3,

characterized in that on the compressed gas containing chamber(s) (7) there are apertures for charging using the dynamic pressure of wind.

6. A watercraft according to any one of claims 1 to 5,

characterized in that said stay rope(s) (2) is/are held with an element (5) for varying the length of said stay rope(s) (2) between said sheet element (1) and said body (3) of the watercraft on said body (3) of the watercraft.

7. A watercraft according to claim 6,

characterized in that said each stay rope (2) is individually held on said body (3) of the watercraft with said element (5) for varying its length.

8. A watercraft according to claim 1,

characterized in that said point (4) of application of force is variable along a guide (8, 9) attached to said body (3) of the watercraft.

9. A watercraft according to claim 1,

characterized in that said point (4) of application of force is excentrically disposed on a rotary table (11) attached to said body (3) of the watercraft.

10. A watercraft according to claim 1,

characterized in that said point (4) of application of force is disposed on a pivotable jib boom (10) attached to said body (3) of the watercraft.

11. A watercraft according to any one of claims 1 to 10, characterized in that said point (4) of application of force is variable with respect to the lateral straining point of said body (3) of the watercraft.
12. A watercraft according to any one of claims 1 to 11, characterized in that said point (4) of application of force is variable in parallel and/or orthogonally with respect to the longitudinal axis of the watercraft.
13. A watercraft according to any one of claims 1 to 12, characterized in that the length of each said stay rope (2) is individually variable.
14. A watercraft according to any one of claims 1 to 13, characterized in that each said stay rope (2) is wound up on a separate pulley (5).
15. A watercraft according to any one of claims 1 to 14, characterized in that said stay ropes (2) are guided over at least one deflection pulley (6).
16. A watercraft according to claim 15, characterized in that said deflection pulley(s) (6) is (are) movable.
17. A watercraft according to any one of claims 1 to 16, characterized in that said three stay ropes (2) are held on the body (3) of the watercraft and attached to said sheet element (1) at three points spanning a triangle.
18. A watercraft according to any one of claims 1 to 16, characterized in that said four stay ropes (2) are held on said body (3) of the watercraft and attached to said sheet element (1) at four points spanning a rectangle.
19. A watercraft according to any one of claims 1 to 18, characterized in that said compressed gas containing chamber(s)(7) is (are) formed at the edge of said sheet element (1).
20. A watercraft according to any one of claims 1 to 19, characterized in that the lifting force of said compressed gas containing chamber(s) (7) is greater than or equal to the weight of the sheet element (1).
21. A watercraft according to any one of claims 1 to 20, characterized in that at least one hydrodynamically effective element (31) is arranged on said body (3) of the watercraft.
22. A watercraft according to claim 21, characterized in that said element(s) (3) is (are) pivotable about an axis.
23. A watercraft according to any one of claims 1 to 22, characterized in that the pivoting angle of said element(s) (31) is adjustable depending on the velocity of the watercraft and/or the tensile force of said sheet element (1).
24. A watercraft according to any one of claims 1 to 23, characterized in that on said sheet element (1) at least one aerodynamically effectively pivotable element (32) is present.
25. A watercraft according to any one of claims 1 to 24, characterized in that a leeboard attached to said body (3) of the watercraft is rotatable with respect to the longitudinal axis.
26. A watercraft according to any one of claims 1 to 25, characterized in that at least one sensor string guided toward said body (3) of watercraft is attached to said sheet element (1).
27. A watercraft according to any one of claims 1 to 26, characterized in that elements protecting from overload are present on said stay rope(s) (2).
28. A watercraft according to any one of claims 1 to 27, characterized in that wind stall elements are present at the outer edges of said sheet element (1).
29. A watercraft according to any one of claims 1 to 28, characterized in that stay rope sling elements (35) are present on said body (3) of the watercraft.
30. A wind propulsion according to any one of claims 1 to 29, characterized in that at least said one compressed gas containing chamber (7) can be connected to at least one compressed gas accumulator (104) by means of one first conduit (111) and one valve (102), and said compressed gas containing chamber (7) can be charged from said gas accumulator (104).
31. A wind propulsion according to claim 30, characterized in that a second conduit (103) which can be connected to said compressed gas containing chamber (7) or which is connected to said first conduit (111) is present for the recirculation of gas from said compressed gas containing chamber (7) into at least said one or a second compressed gas accumulator (104, 114).
32. A wind propulsion according to claims 30 or 31, characterized in that at least said first conduit (111) is regionally formed in a flexible manner.
33. A wind propulsion according to any one of claims 30 to 32, characterized in that a compressor (107) is provided in an in-line arrangement with said second conduit (103).
34. A wind propulsion according to any one of claims 20 to 33, characterized in that in said first compressed gas accumulator (104) a pressure of said compressed gas, which is greater than or equal to the internal pressure in said compressed gas containing chamber (7), is met.
35. A wind propulsion according to any one of claims 30 to 34, characterized in that the induction side of said compressor (107) is mounted to said compressed gas containing chamber (7), and the delivery side thereof is mounted to said compressed gas accumulator (104, 114) in said second conduit (103).
36. A wind propulsion according to any one of claims 30 to 35, characterized in that said second conduit (103) with said compressor (107) is connected to said first conduit (111) in the form of a by-pass around said valve (102).
37. A wind propulsion according to any one of claims 30 to 35, characterized in that said first conduit (111) is guided around said compressor (107) as a by-pass, and a two-way valve is arranged in said first conduit (111).

**38.** A wind propulsion according to any one of claims 30 to 37,

characterized in that said compressed gas containing chamber (7) and said compressed gas accumulator (104) are charged with a gas which has a density lower than gas.

**39.** A wind propulsion according to any one of claims 30 to 38,

characterized in that at least said one compressed gas accumulator (104, 114) can be attached to the water-craft.

**40.** A water craft according to any one of claims 30 to 38, characterized in that on said compressed gas containing chamber (7) at least one lockable connecting branch (108) is present for said first conduit (111).

\* \* \* \* \*