

(19)
(12)

(KR)
(Y1)

(51) 。 Int. Cl.7
H01L 21/66

(45)
(11)
(24)

2004 11 26
20-0368650
2004 11 15

(21) 20-2004-0025645 ()
(22) 2004 09 07
(62) 10-2004-0071146
: 2004 09 07

2004 09 07

(73) 96-1

(72) 96-1

96-1

2 5441-1

918

(74)

:

(54)

(test handler) , (package)
; 가 (feeder);
;
;

1 ;

2 가 ;

3 ;

4 .

*

110 :

120 :

130 :

140 :

ge) (test handler) , (packa

(Chip) (Packaging)

가 . 가 (Package)

(tester) (Final test) (handler) ,

() ()

(LEAD) (stand off)

가 가

(feeder);

가

;

;

;

;

.

1

;

,

2

;

1

2

,

.

가

2

,

,

,

,

,

;

;

;

;

가

;

;

,

;

,

가

가

가

,

.

,

1

4

.

,

1

4

,

1

3

,

2

가

4

1 2 , (100) , ,
 (102), (110), (112), (120), (130), (140),
 (110) 가 (112) 30 12 가 (10)
 (102) (112) (112) 30 12 가 (112) (10)
 (10) 30 12 (p1-p12) ,
 30 , (30 , ,
)
 , (102) (112) (10)가 1 4 , 1 (p1)
 가 3 (s12). 2 (p2) (112) 가 3
 (s14). 7 (p7) (p3-p5) (, ,
) (s16). 8 (p8) (180) (, ,
 (s18). 9 (p9) ()가 (s20). 10 (p10)
 (10)가 (112) , (150)
 (160) (s22). 11 (p11)
 가 (170) (s24).
 (120) 3,4,5 (10)
 (122) , (122) (10) (10) (12) 가
 (120) 가 (122) (10) 가
) (130) 7 , (130) (130) (10)
 (p9) 8 (p8) (180) 9
 2 3 , (140) 가 (140)
 (130) ()
 (140) 1 (142), 2 (144), (146) (148) 1,2 (1
 42,144) (146) 9 (p9) , 2 (144) (142) (1
 10) () (12) (12a) , (146) (146) 2 (144)
 (12) 가 (146) 2 (144)
 (148) 1 (142)
 () (148) 2 (144)
 () (stand-off)
 , 3 가 (12)가 ()가 ,
 가
 (148) 가 (148)
 () 가 ()
 148) 가
 ,
 12) , (144)가 (12) ()
 (12a) , 가 ()

9 (p9) 가 10 (p10) 가 (10)
 가 10 (160) 가 (114) (reel;162) (150)
 12) 가 (10) (112) 11 (p11) (170) (1
 가

가

가

(57)

1.

(feeder);

가

2.

1

1 ;

2 ;

1 2 ,

2 3. ,

가

2 ,

2 4. ,

2 5. ,

2 6. ,

2 7. ,

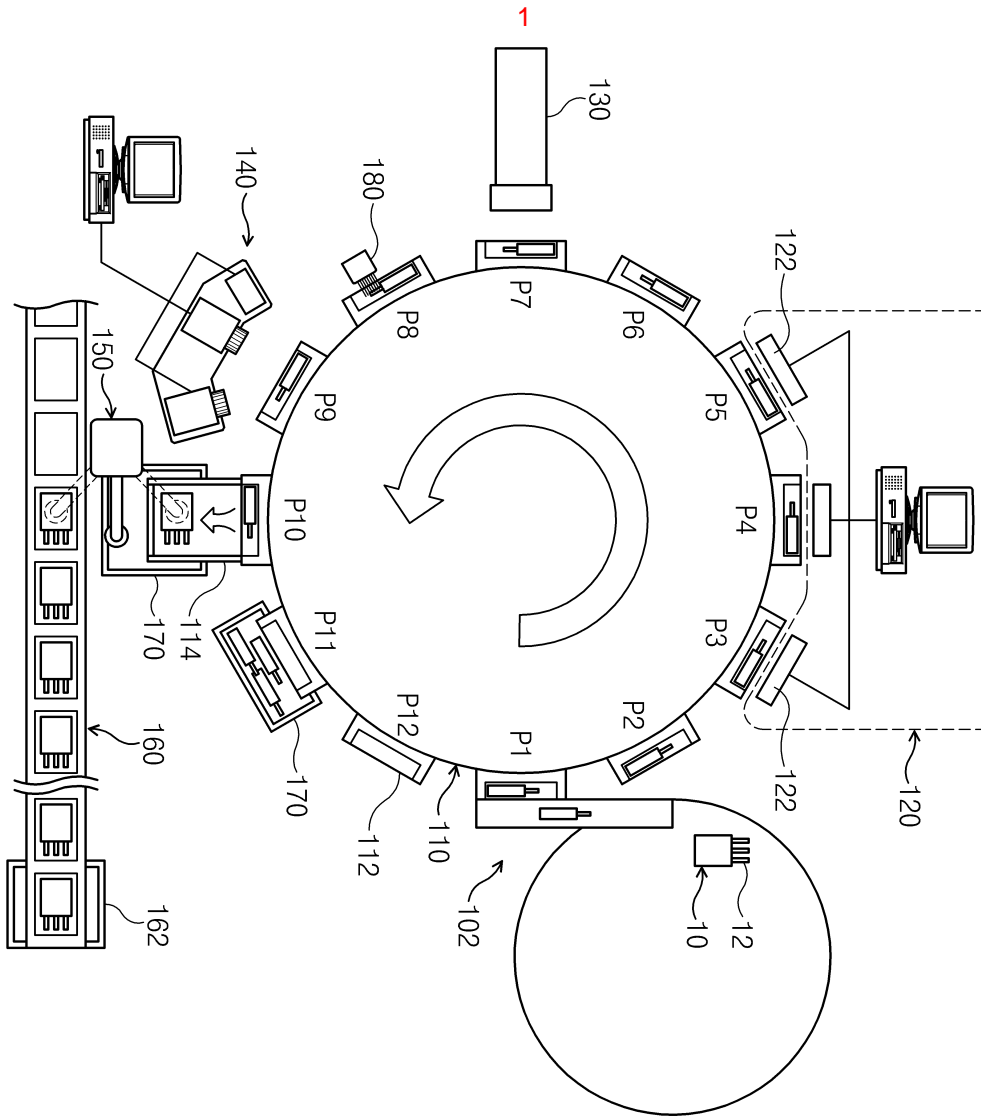

2

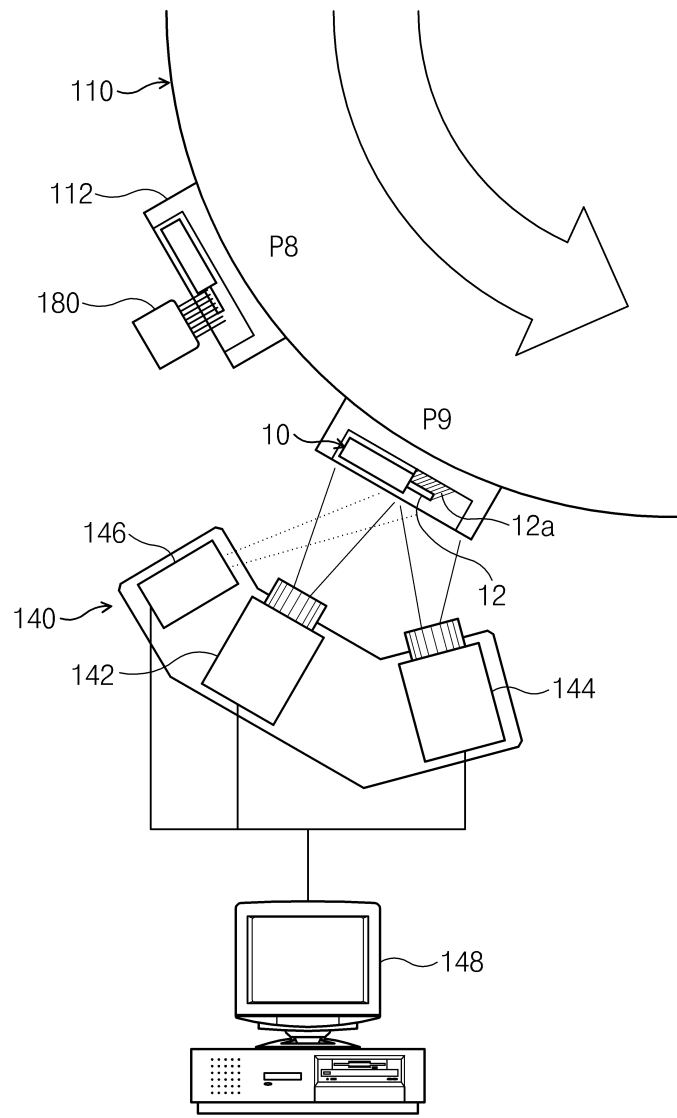

3

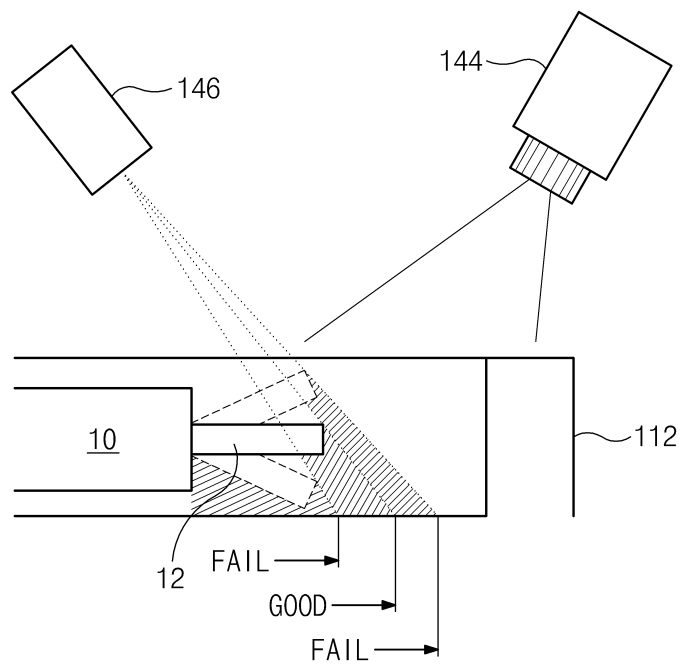

4

