



(22) Date de dépôt/Filing Date: 2004/03/19

(41) Mise à la disp. pub./Open to Public Insp.: 2005/09/19

(51) Cl.Int.⁷/Int.Cl.⁷ E04F 11/025

(71) Demandeur/Applicant:
COUTURE, RAYMOND, CA

(72) Inventeur/Inventor:
COUTURE, RAYMOND, CA

(74) Agent: GOUDREAU GAGE DUBUC

(54) Titre : LIMON ET SUPPORTS DE MARCHES POUR ESCALIERS

(54) Title: STRINGER AND STEP SUPPORT KIT FOR STAIRWAYS

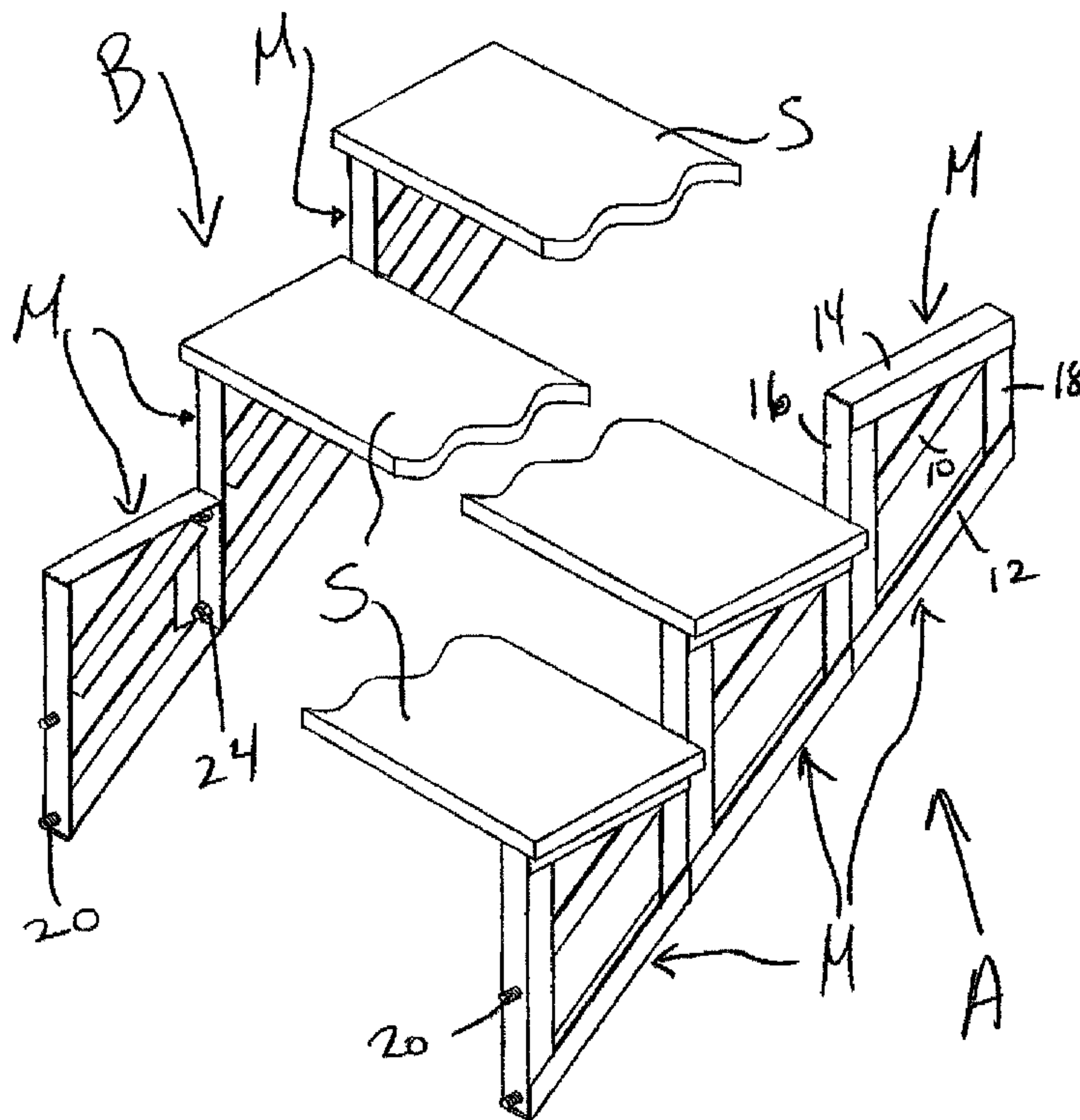

STRINGER AND STEP SUPPORT KIT
FOR STAIRWAYS

BACKGROUND OF THE INVENTION

1. Field of the Invention

The present invention relates to stairways and, more particularly, to modular stairways made of pre-fabricated components such as stringers, step supports, railings, etc., typically in the form of a kit for assembly on site.

2. Description of the Prior Art

Typically, staircases are completely produced on site with the various wood components being cut to size as the staircase is progressively erected on site. Furthermore, the finishing of a staircase is often damaged during construction, namely the carpeting that covers the steps or the solid wood finishing thereof. It is virtually impossible to defer the installation of the finishing covering of the steps of the staircase until the end of the construction thereby resulting in damages to this finishing during the final stages of the construction.

Also, it has been proposed to completely assemble a staircase in the factory such that a pre-assembled staircase is delivered to the construction site for direct and easy installation thereat. Such a modular staircase is disclosed in the Canadian Application No. 2,149,981 naming Raymond Couture as inventor and laid-open for public inspection on November 24, 1995.

Furthermore, in Canadian Application No. 2,276,988 also naming Raymond Couture as inventor and laid-open for public inspection on December 30, 1999, a modular staircase is proposed that includes a permanent framing made of metallic stringers and

vertically extending step supports that are secured along the stringers. Each step support includes upper and front flanges adapted to be secured respectively to a tread and to a riser of each step of the staircase. If the staircase has a partly exposed side, various decorative or finishing wooden components, including treads, risers, false or decorative stringers, mouldings, etc., are provided to cover any exposed structural metallic framework and particularly the stringers.

SUMMARY OF THE INVENTION

It is therefore an aim of the present invention to provide a novel stairway made of individual components, e.g. in the form of a kit.

DESCRIPTION OF THE PREFERRED EMBODIMENTS

The present invention will now be herein described with reference to the accompanying drawings, which show by way of illustration preferred embodiments thereof.

Generally, it is well known that stairways basically consist of two parallel stringers and to which are mounted the steps (horizontal) as well as, in most cases, risers (i.e. the vertical back section extending between two successive steps). Typically, wooden stringers have a see-saw upper profile defining successive vertical and horizontal edges for mounting thereto respectively the risers and the steps. In the construction of modular stairways, step supports generally offering the aforementioned horizontal and vertical edges are separate components from the stringers and are mounted, with bolts or by welding, to the stringers, the latter generally consisting of a metallic beam extending at the angle of the intended stairway. The step supports are generally separate from the stringers such that they

can be adjustably mounted thereto in order to vary the height and/or depth of the stairway's steps.

In the present invention, there is provided a new module which doubles as both a step support and part of a stringer, as seen in Drawing Sheets Nos. 1 to 3. Such a module M is illustrated in Figure 1 and it consists of five members (herein metallic and L-shaped), that is upper and lower stringer members 10 and 12 (that act as part of a stringer), an upper step support 14, and front and rear supports 16 and 18, respectively. Threaded shafts 20 are fixedly horizontally mounted, typically by welding, to the lower half of the front support 16 such that they can be engaged in the openings 22 defined in the rear support 18 of an adjacent module M, as depicted at M' in Figure 2 and which is disposed in front and partly below the module M. Nuts 24 are used to secure the modules M and M' together. The modules M and M' are identical.

The openings 22 shown in Figure 1 are preferably vertically oblong in order to allow for vertical adjustment between the modules M and M'.

Therefore, by juxtaposing and connecting a series of modules M, a combination stringer and step support is provided as illustrated in Figures 2 and 3 (see assemblies A and B in Figure 3). The two distinct assembled series A and B of modules M can then be positioned parallelly (see Figure 3) before steps S are mounted to the step supports 14 of the various modules M of the assemblies A and B, as well as possibly risers (not shown) that would be mounted to the upper, i.e. visible, halves of the front supports 16.

In Drawing Sheet No. 4, there is shown a variant 100 of the module M of Drawing Sheets Nos. 1 to 3, this variant including a sliding connector 102

for joining together two adjacent modules 100 while allowing for height adjustment between both modules 100 (see the oblong openings in the connector 102). An adjustment screw 104 may be provided such a height adjustment. Openings 106 are for receiving the lower ends of a railing's vertical supports.

In Drawing Sheet No. 5, such a novel railing is shown, wherein the vertical supports of the railing are identified by 108 and the handrail thereof is identified by 110. The supports 108 can be made of steel with a wood (or other decorative material) covering 112 being possibly provided around each support 108. The supports 108 can also be made of decorative bronze (or other decorative material), whereby no covering 112 is then required. The handrail 110 can be made of wood, moulded plastic, metal, etc.

Drawing Sheet No. 6 illustrates a step 114 (e.g. made of steel) mounted on the module 100, and a covering 115 (e.g. made of wood, PVC, etc.) for this step 114. The step 114 can be bolted, welded, etc. to the modules 100. The step 114 can be not only structural but also decorative, e.g. made of solid wood (or other well-finished material) such that the covering 115 is not required.

Drawing Sheet No. 7 shows innovative markings 116 that are provided for instance on the sliding connector 102 to more easily provide the desired step height between the modules 100, the markings 116 herein allowing to set step heights from 7 to 8 inches.

In Drawing Sheet No. 8, a novel curved adjustment and stabilising bar 120 links adjacent vertical supports 108 by having its ends engaged to the upper ends of the supports 108. The stabilising bar 120 is secured to the handrail 110 with a fastener 122 and is hidden by hollowness defined on

the underside of the handrail 110. This stabilising bar 120 provides rigidity to the vertical supports 108 and universality as its flexibility allows the same hand rail 110 to be mounted to the vertical supports 108 for different angles of the hand rail 110 resulting from various step heights that the stairways may have.

Drawing Sheet No. 9 illustrates another variant 200 of the module M (that which doubles as both a step support and part of a stringer). Drawing Sheet No. 10 shows a number of cross-sectional views (A to D) taken from the module 200 of Drawing Sheet No. 9. Drawing Sheet No. 10 also illustrates novel wedges that are used for curved stairways, with these wedges forming the angles required depending on the degree of curvature of the stairway. Drawing Sheets Nos. 11 (side views) and 12 (plan view) illustrates such a curved stairway.

Drawing Sheets Nos. 13, 14, 16 and 17 illustrate four further variants 300, 400, 500 and 600 of the novel module M, which are made of cast metal, typically aluminum.

Drawing Sheets Nos. 15, 18 and 19 illustrate a novel ferrule 150 for attaching the stairway, i.e. the uppermost and lowermost modules M (or, 100, 200, 300, 400, 500, 600), to the upper and lower floorings.

Drawing Sheet No. 20 illustrates novel hidden fasteners for the steps and risers.

Sheet No. 11

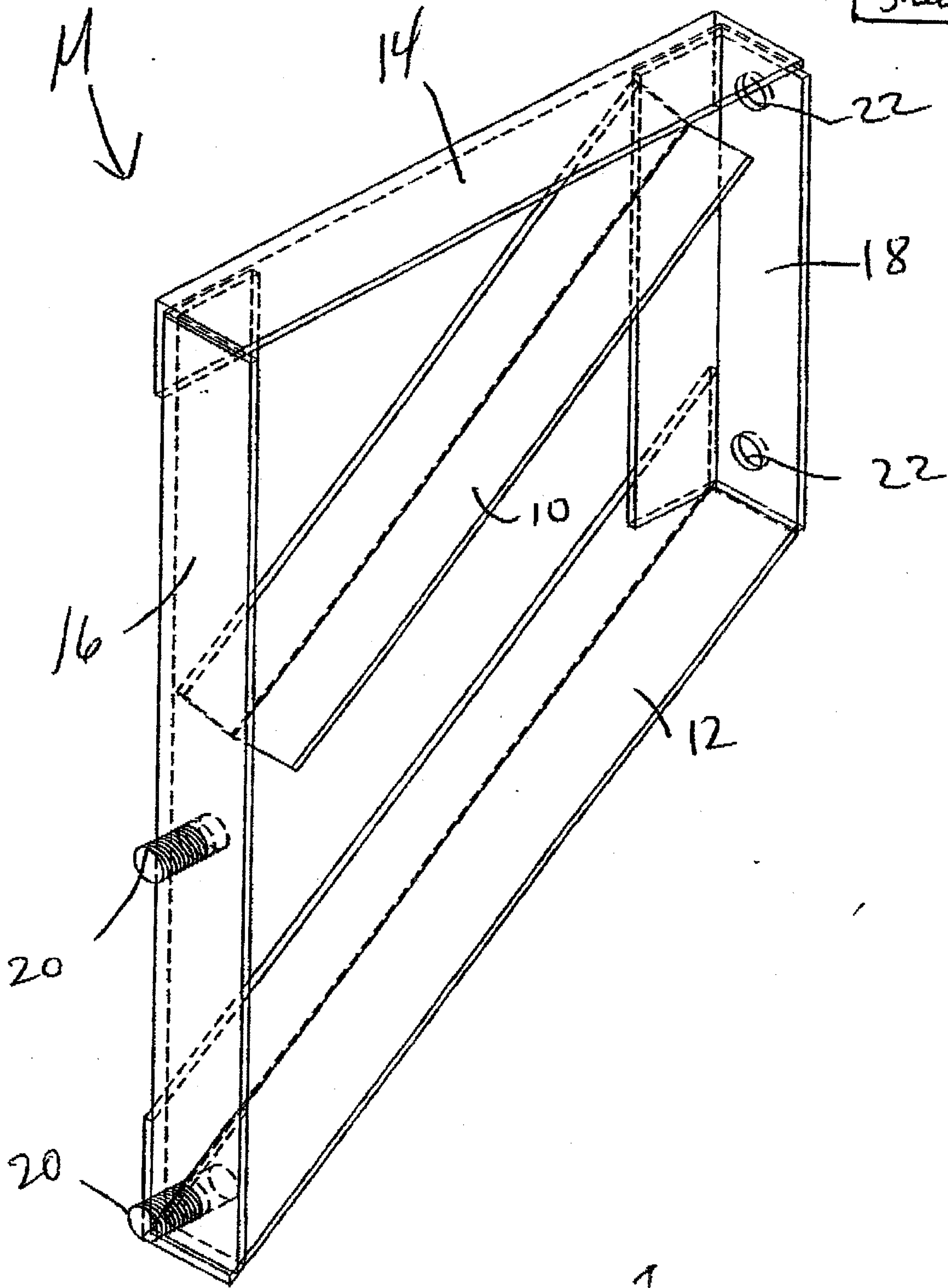

FIG. 1

Sheet No. 2

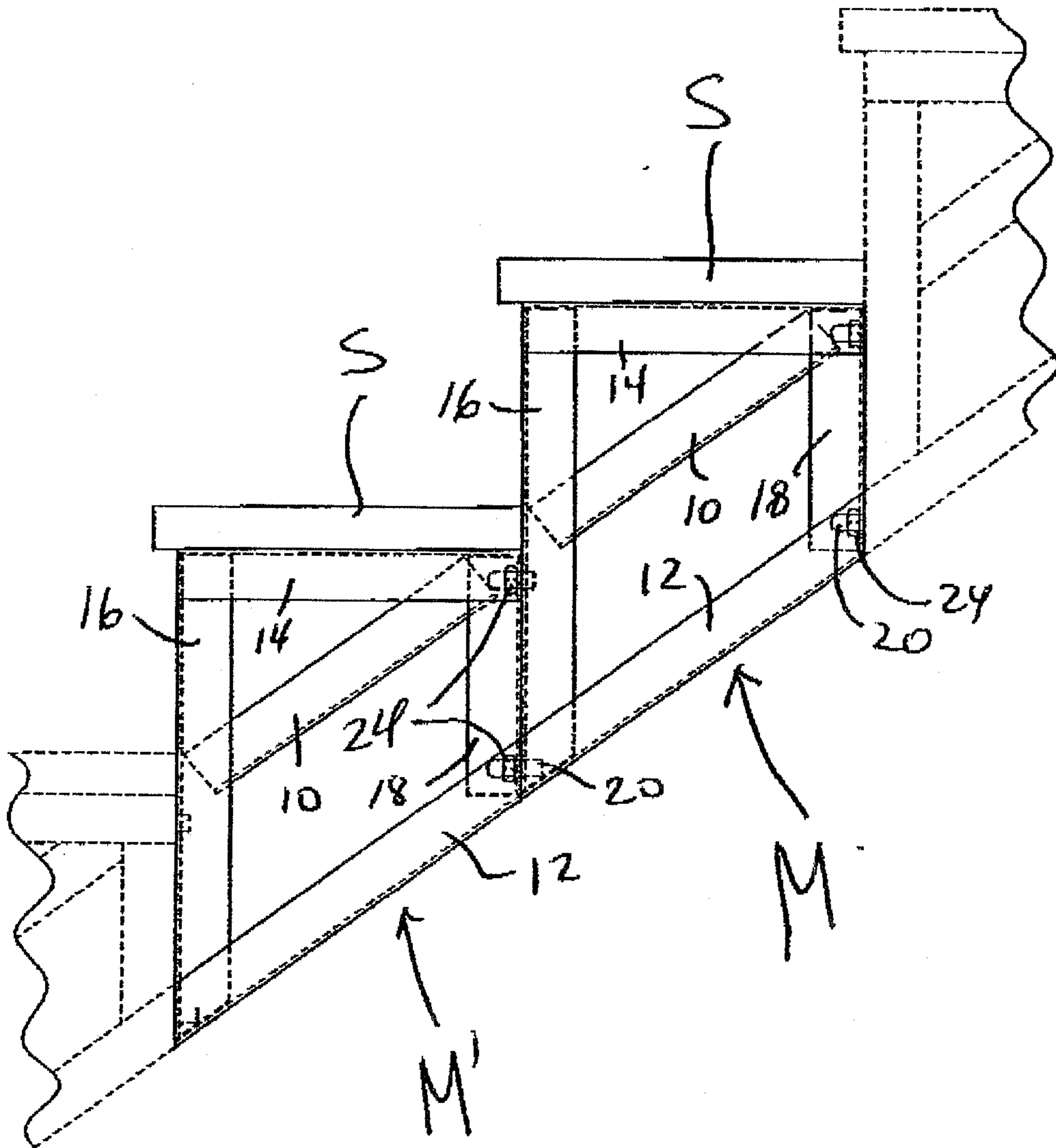

FIG. 2

Sheet No. 3

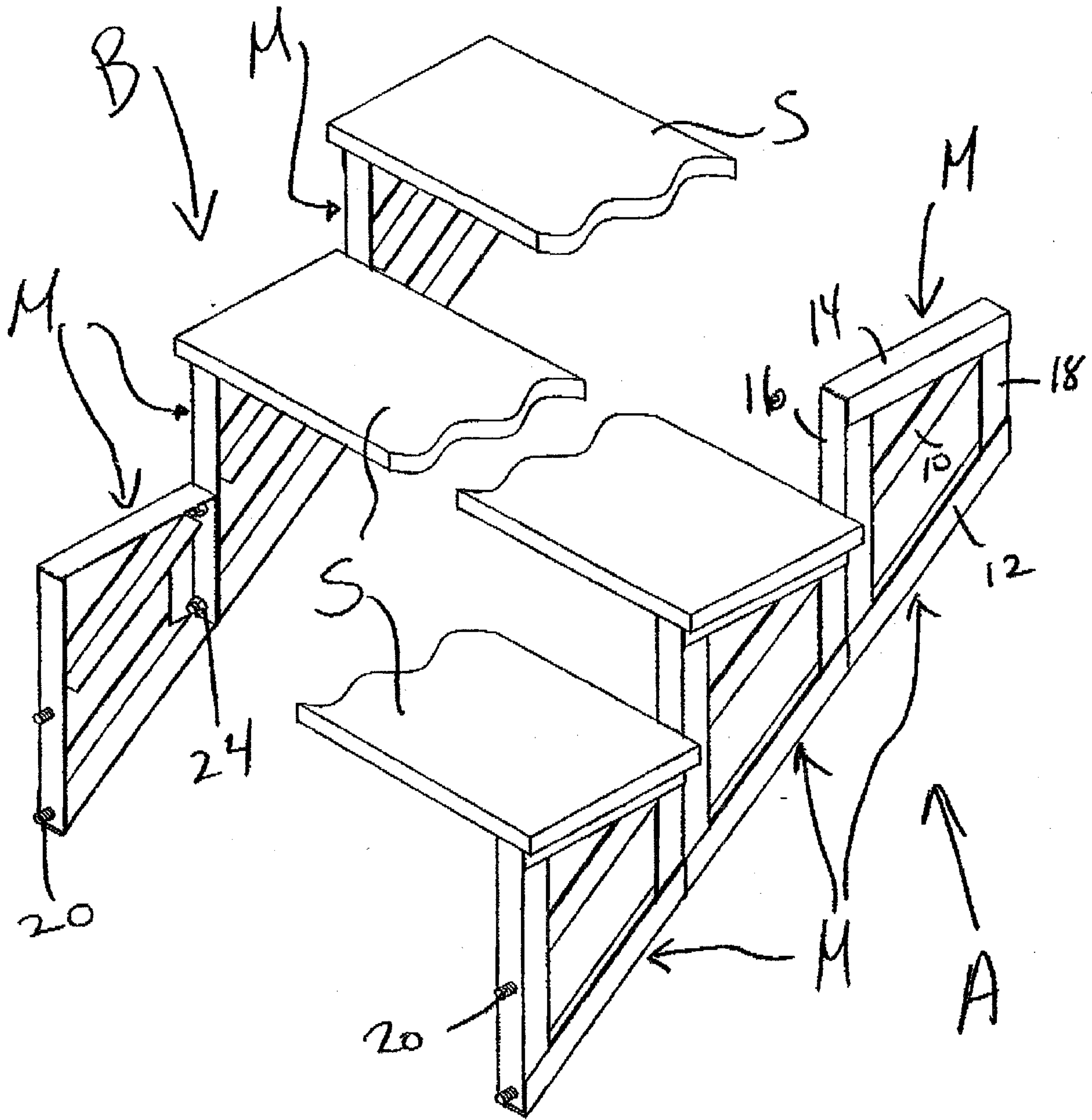
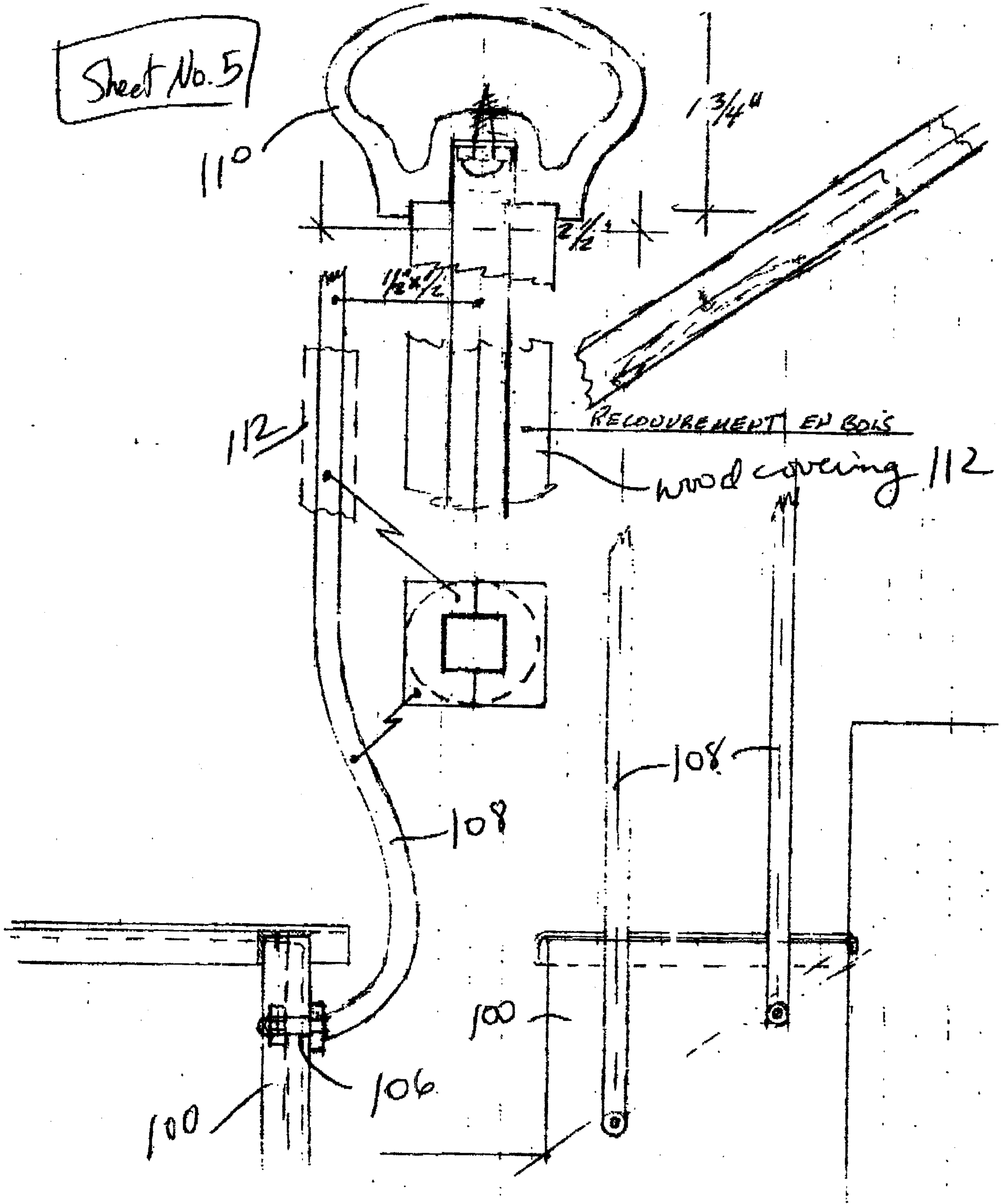

FIG. 3

Sheet No. 5



Sheet No. 6

114

115

REDOUBLEMENTS CONTRE-PLAQUE ACIER
OU MAT PLASTIQUE.

114 P.D.C.

115

114

114

STRUCTURE DELA
MARCHE

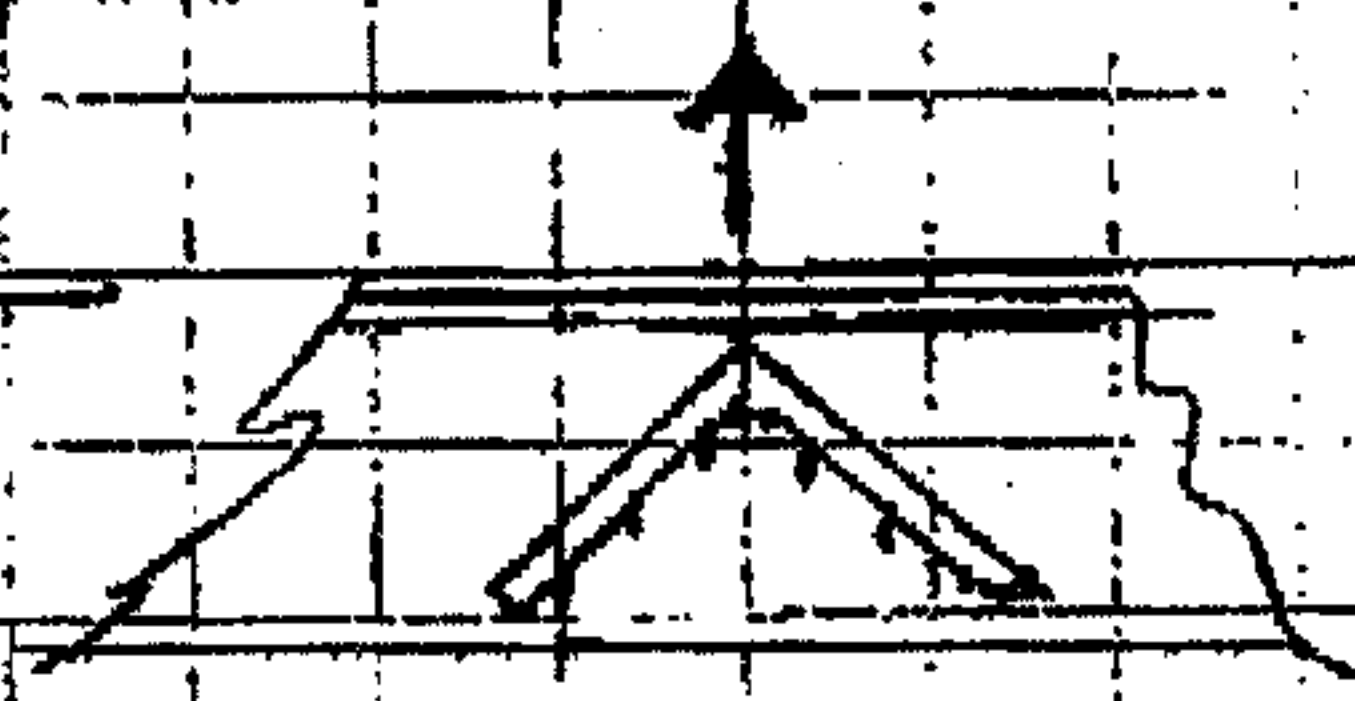

Sheet No. 7

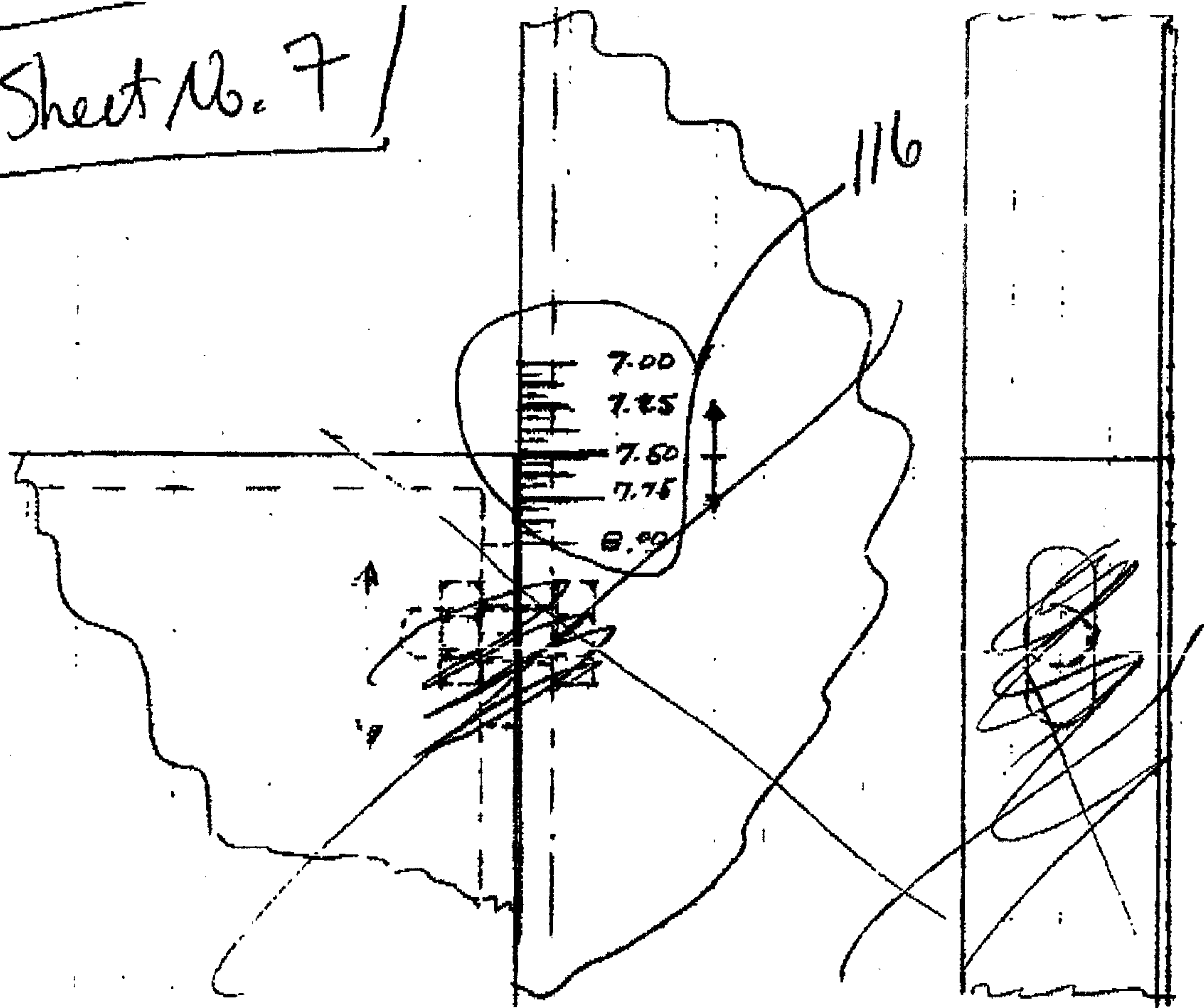

GRADUATION À AJUSTEMENT EN HAUTEUR.

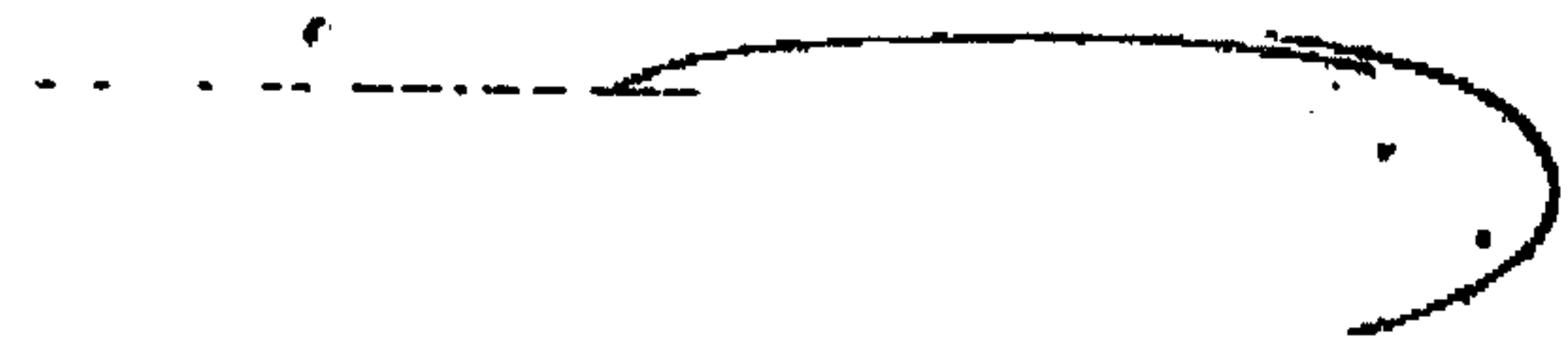

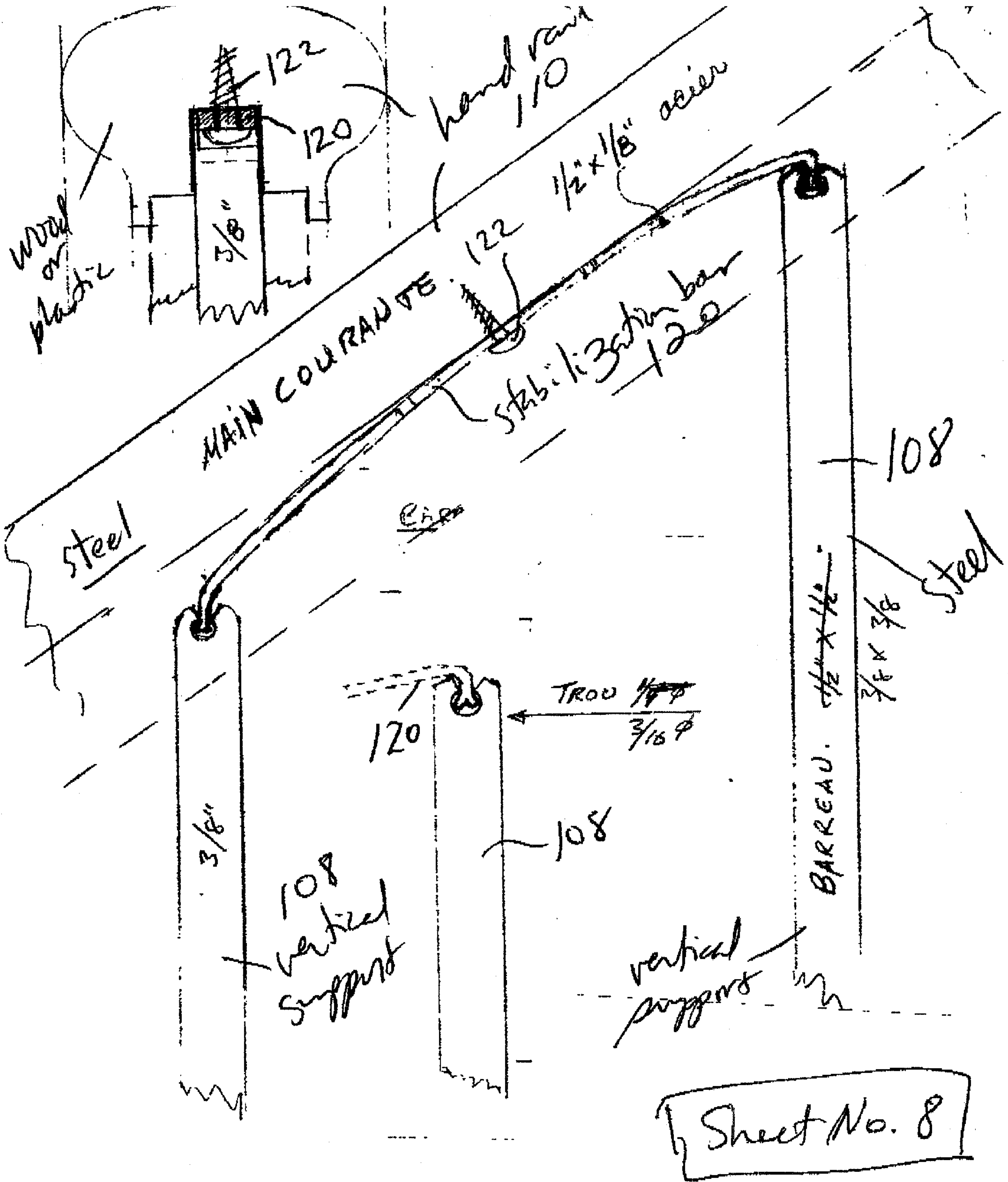

(COURSE RÉGULIÈRE)

9 1/2"

TROUS POUR BARREAU

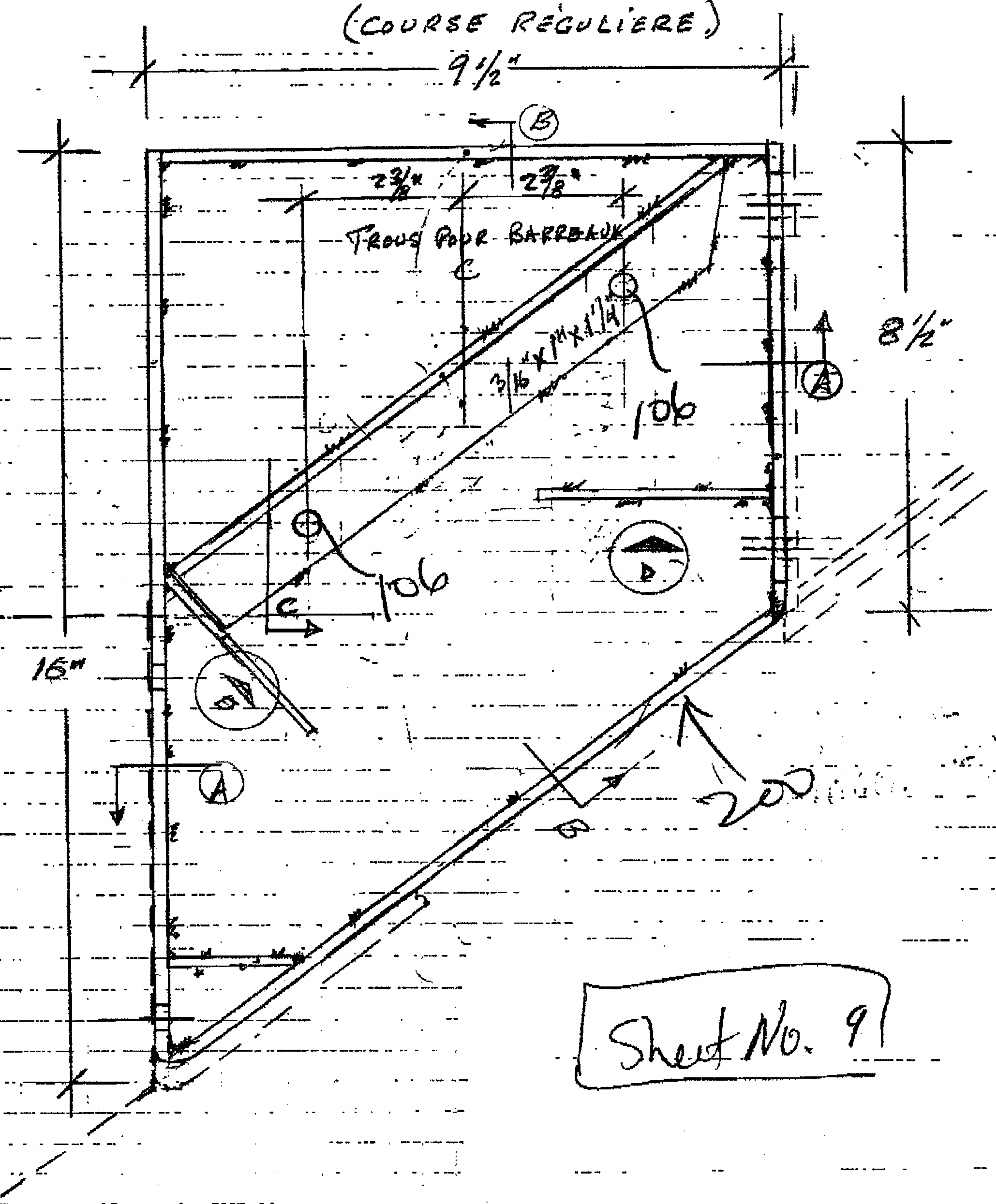

Sheet No. 9

Sheet No. 10

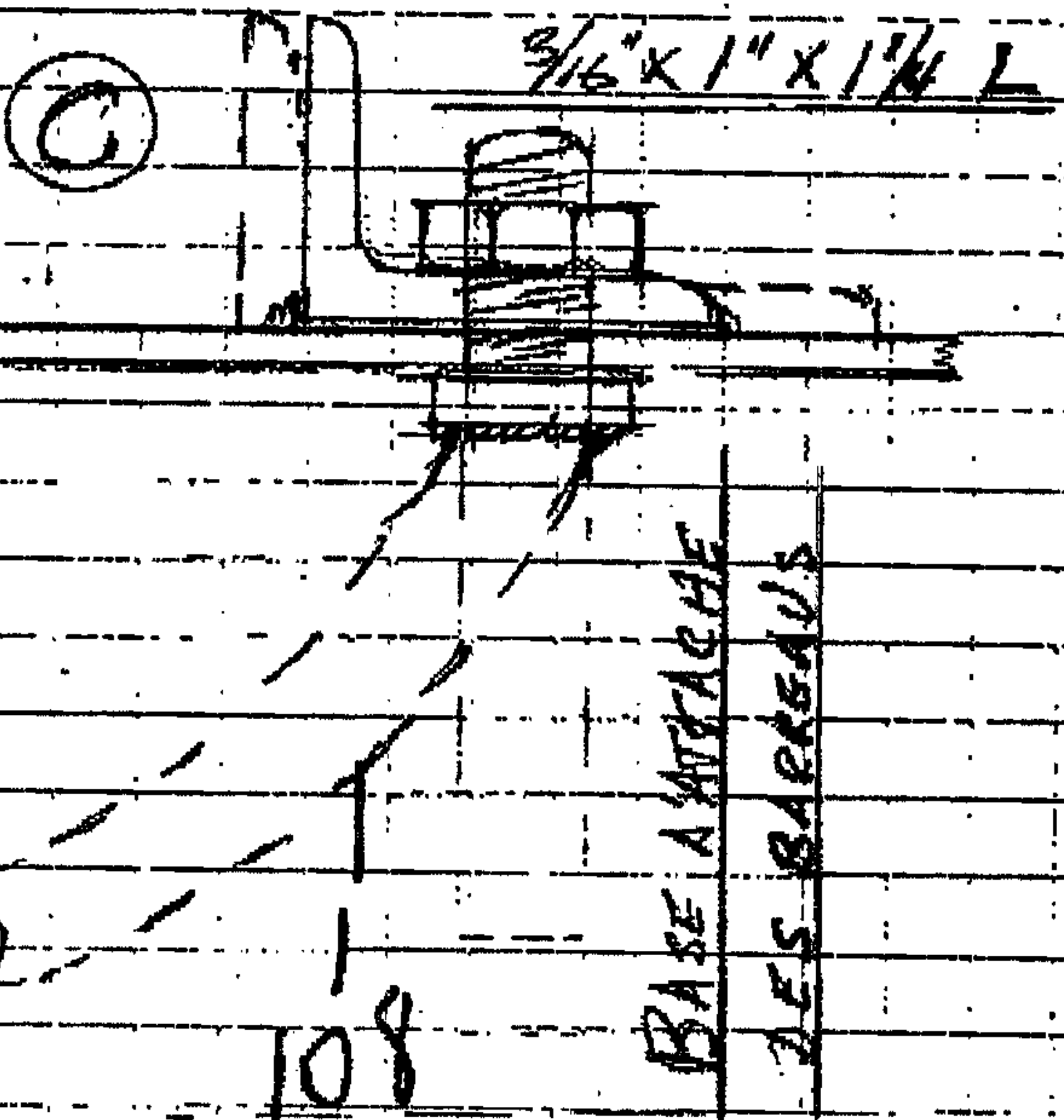
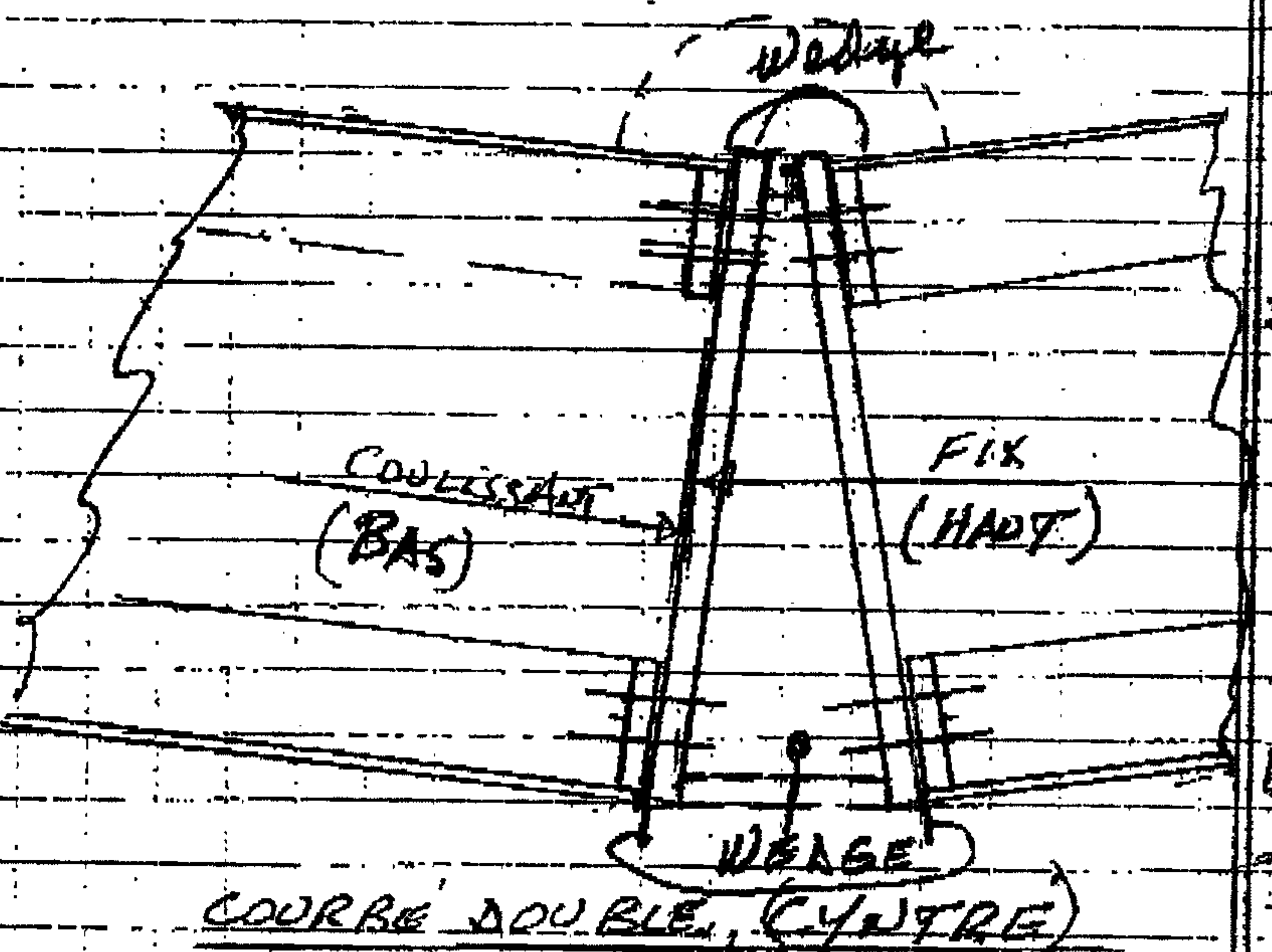
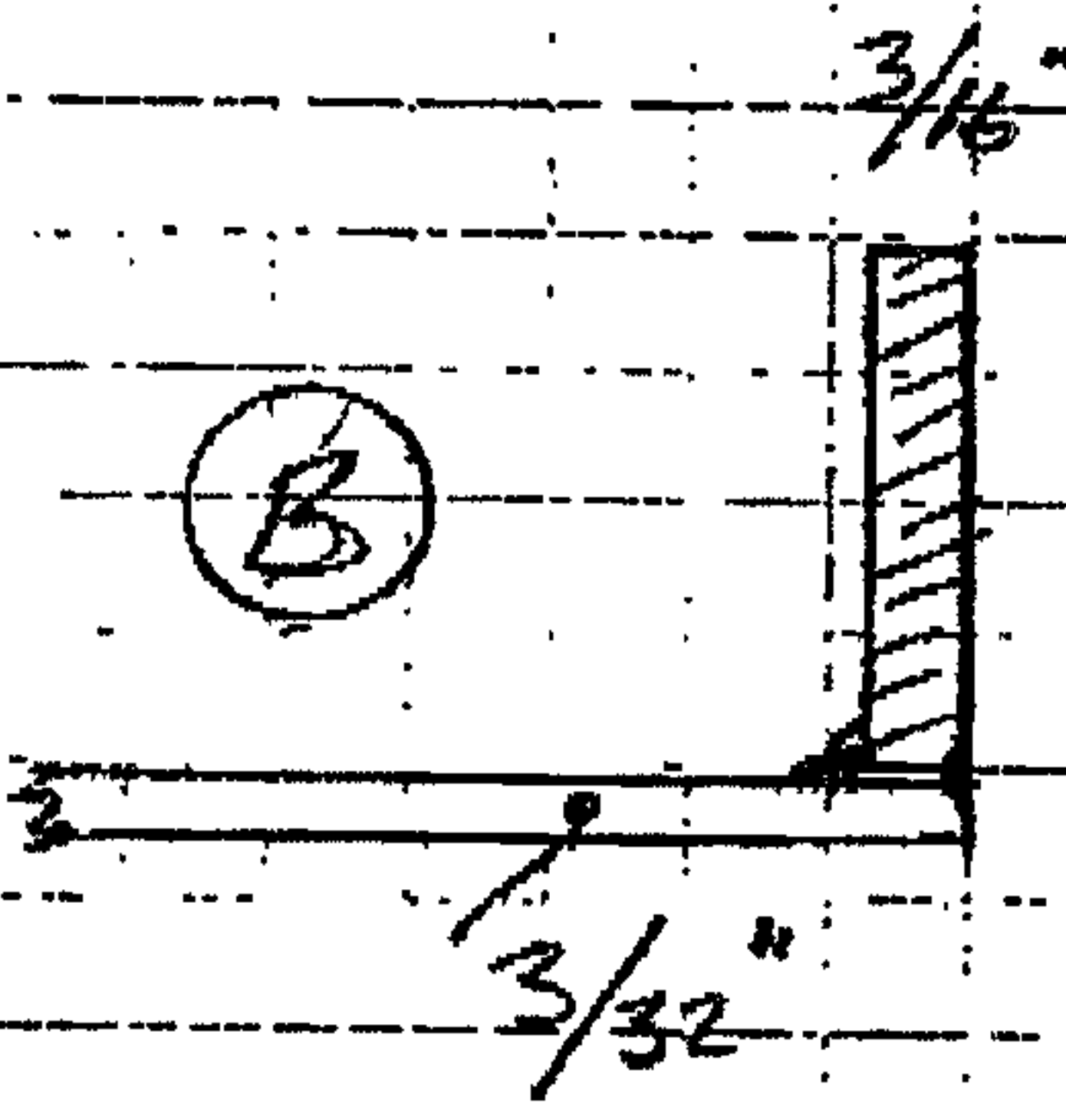
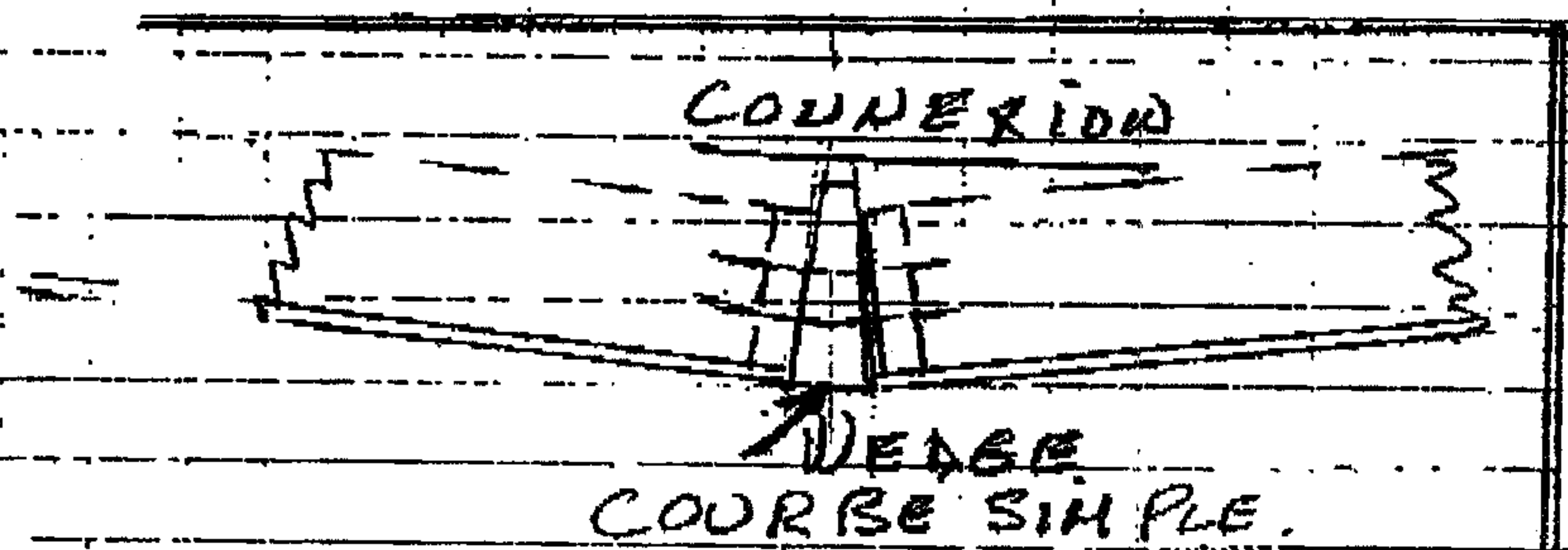
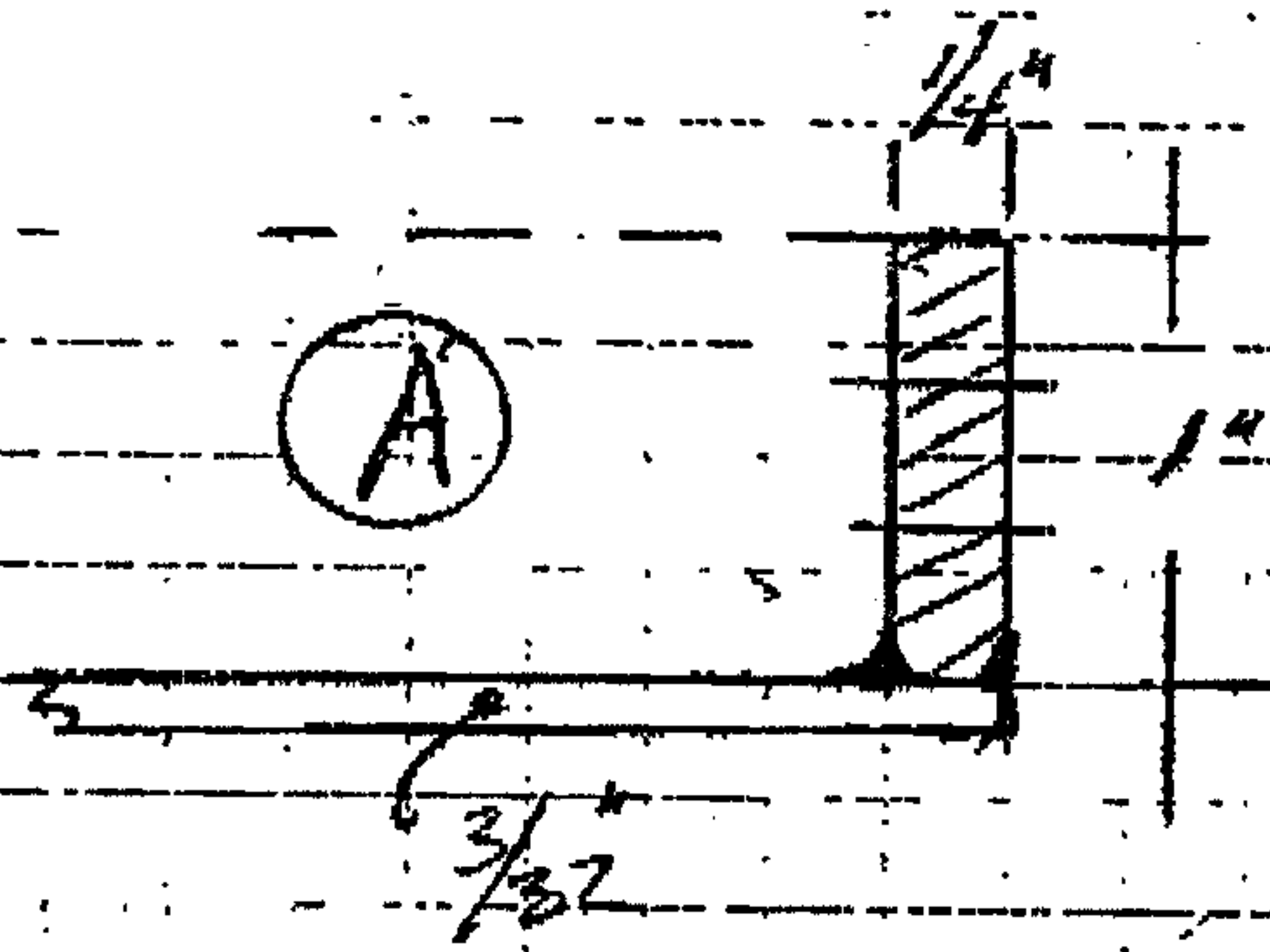
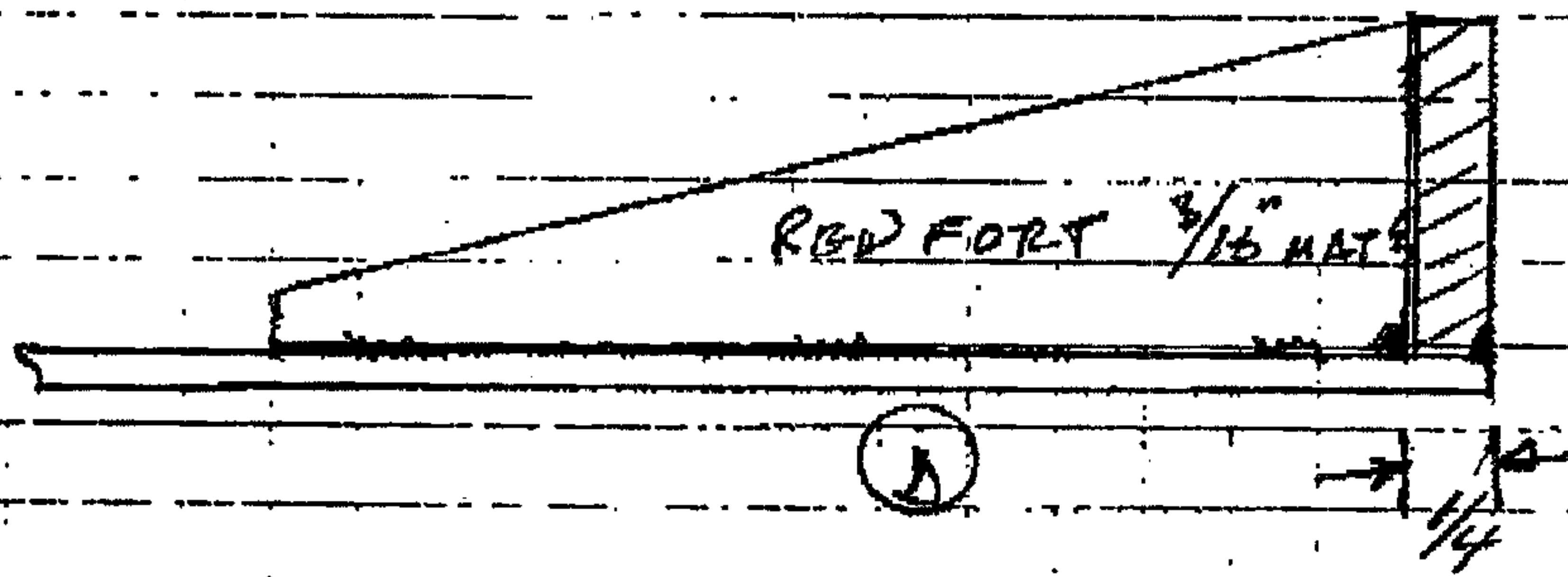

RACCORDS POUR VERSION COURBÉ

Monté en plan

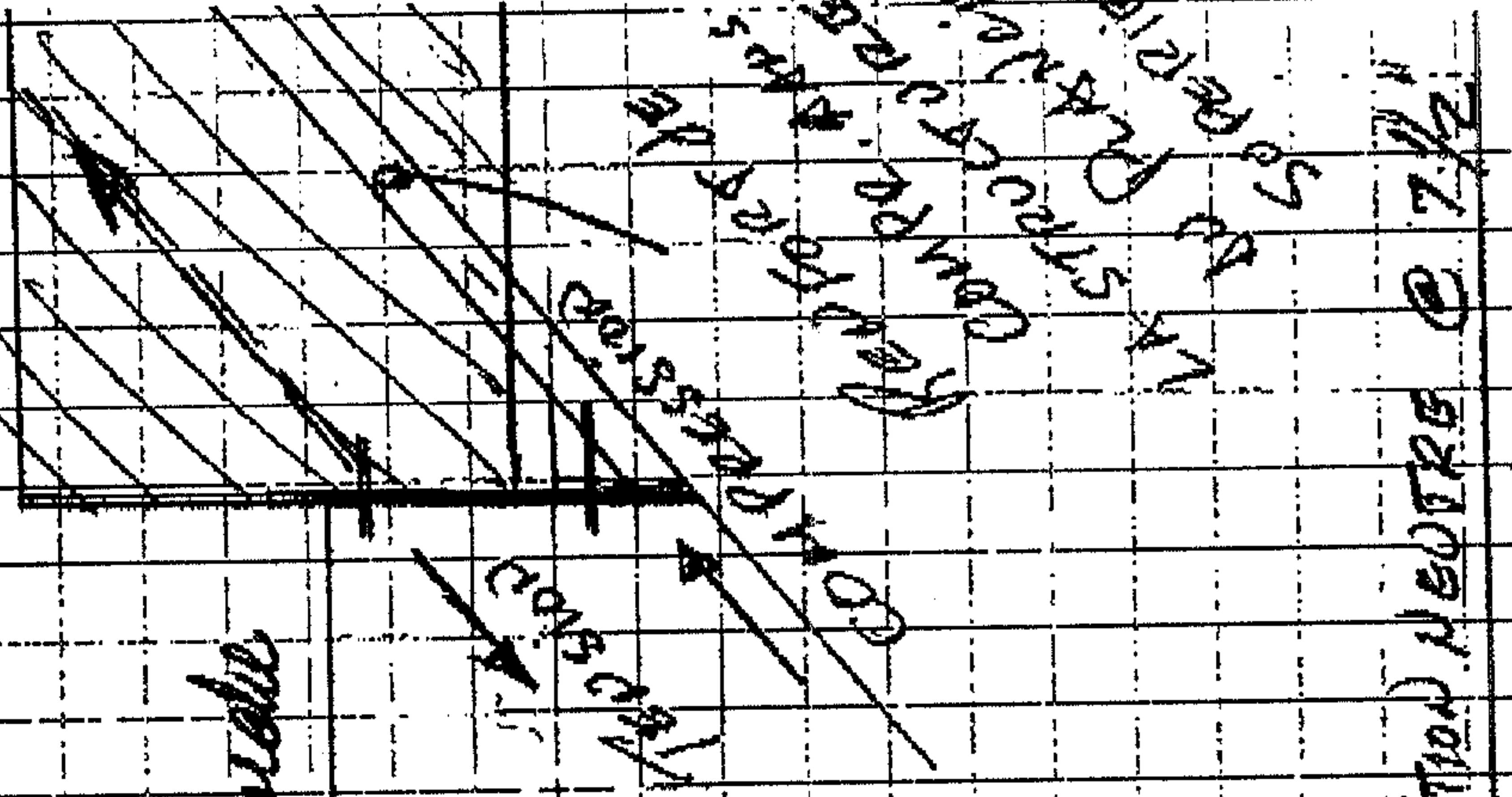

Sheet No. 11

Vue de dessus d'un fort de muraille

a l'intérieur d'une courbe.

Tel 5' int. +
5' ext. +

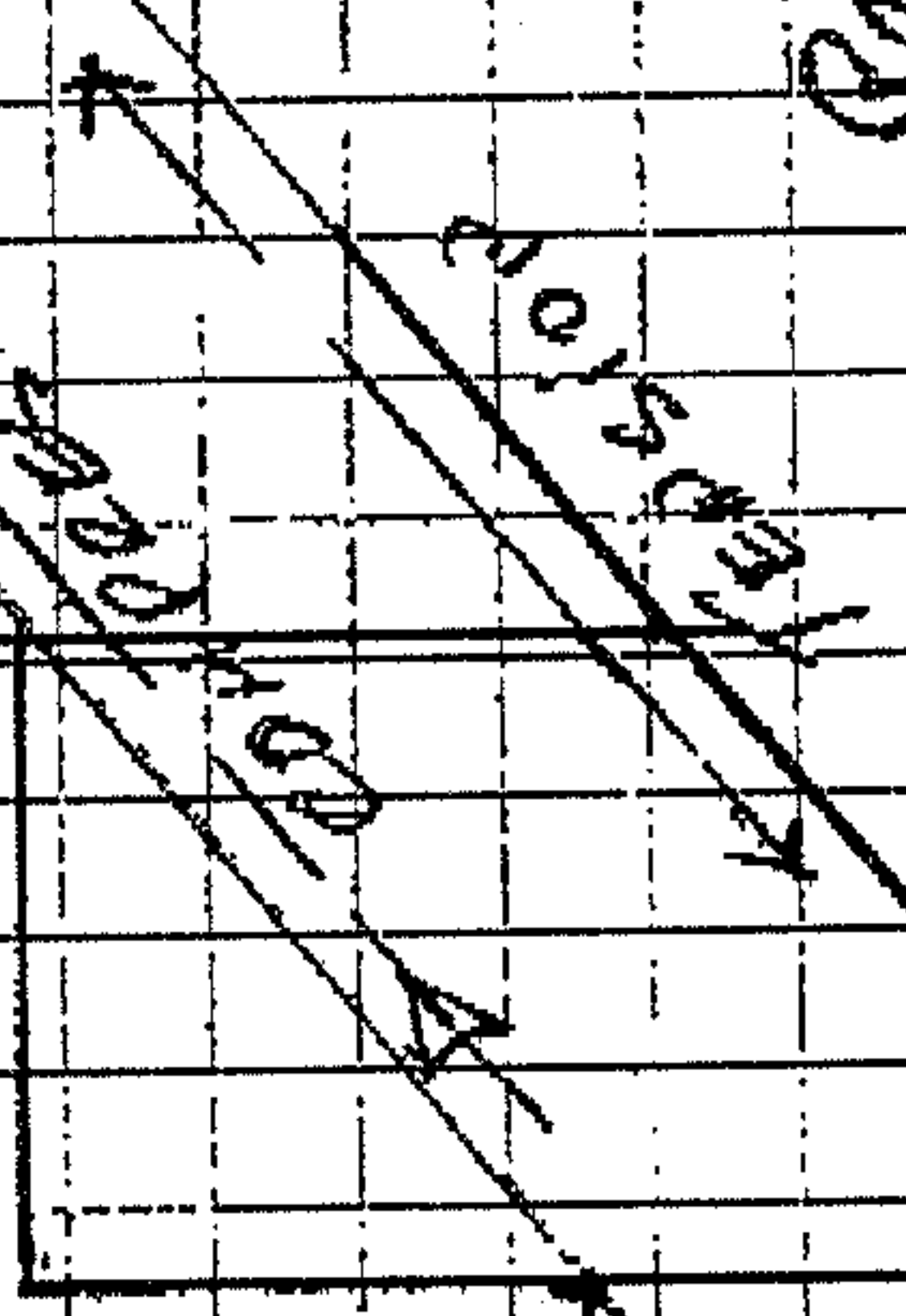

POSITION NEOTRE @ 7 1/2''

S.M. Limon
Droit Handrail

Handwritten signature or initials.

9 1/2''

10' 1/2''

STRUCTURE
LOWER FLOOR

Sketch No. 13

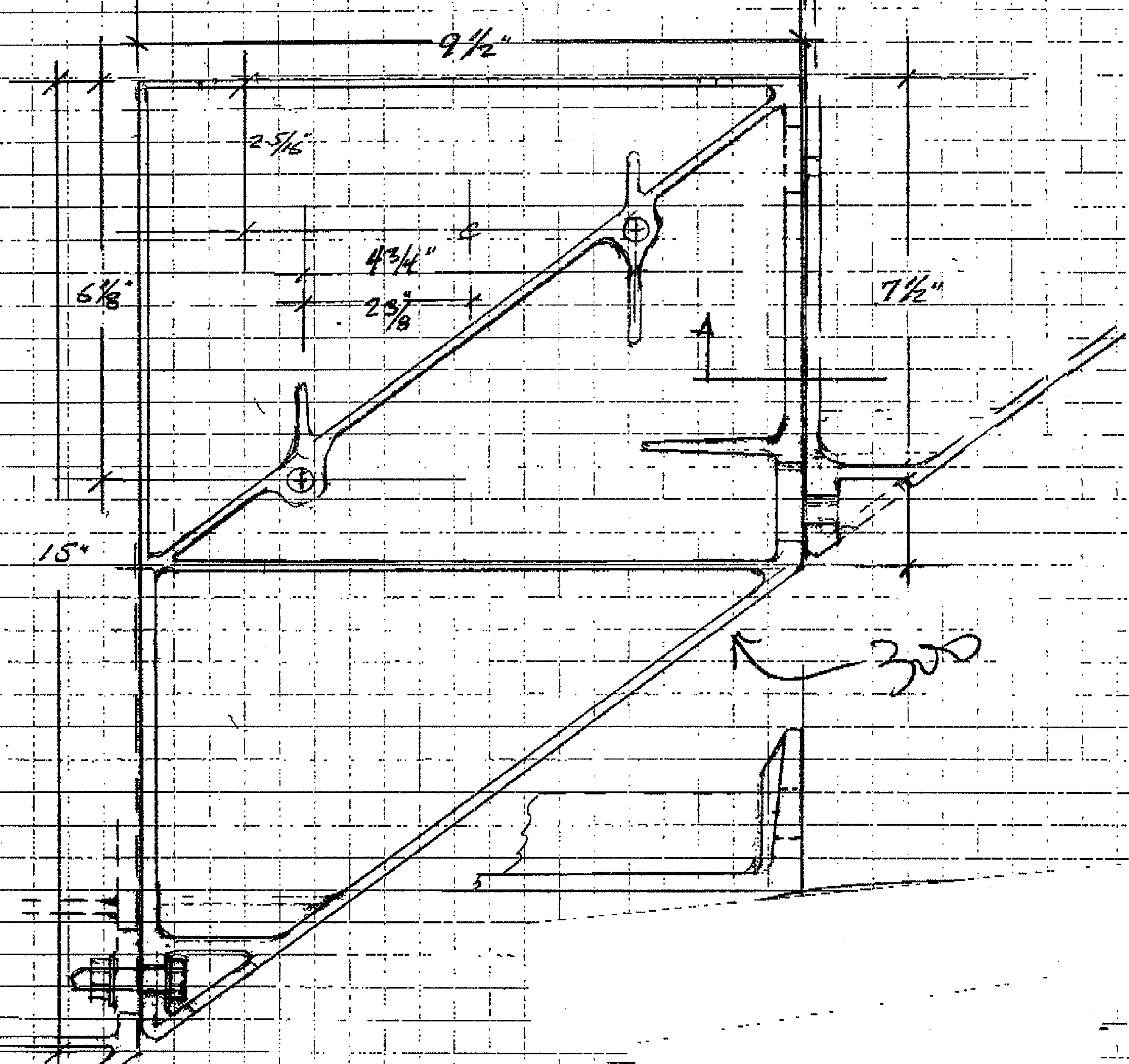

#713 TENZOLOY FLEXIBLE

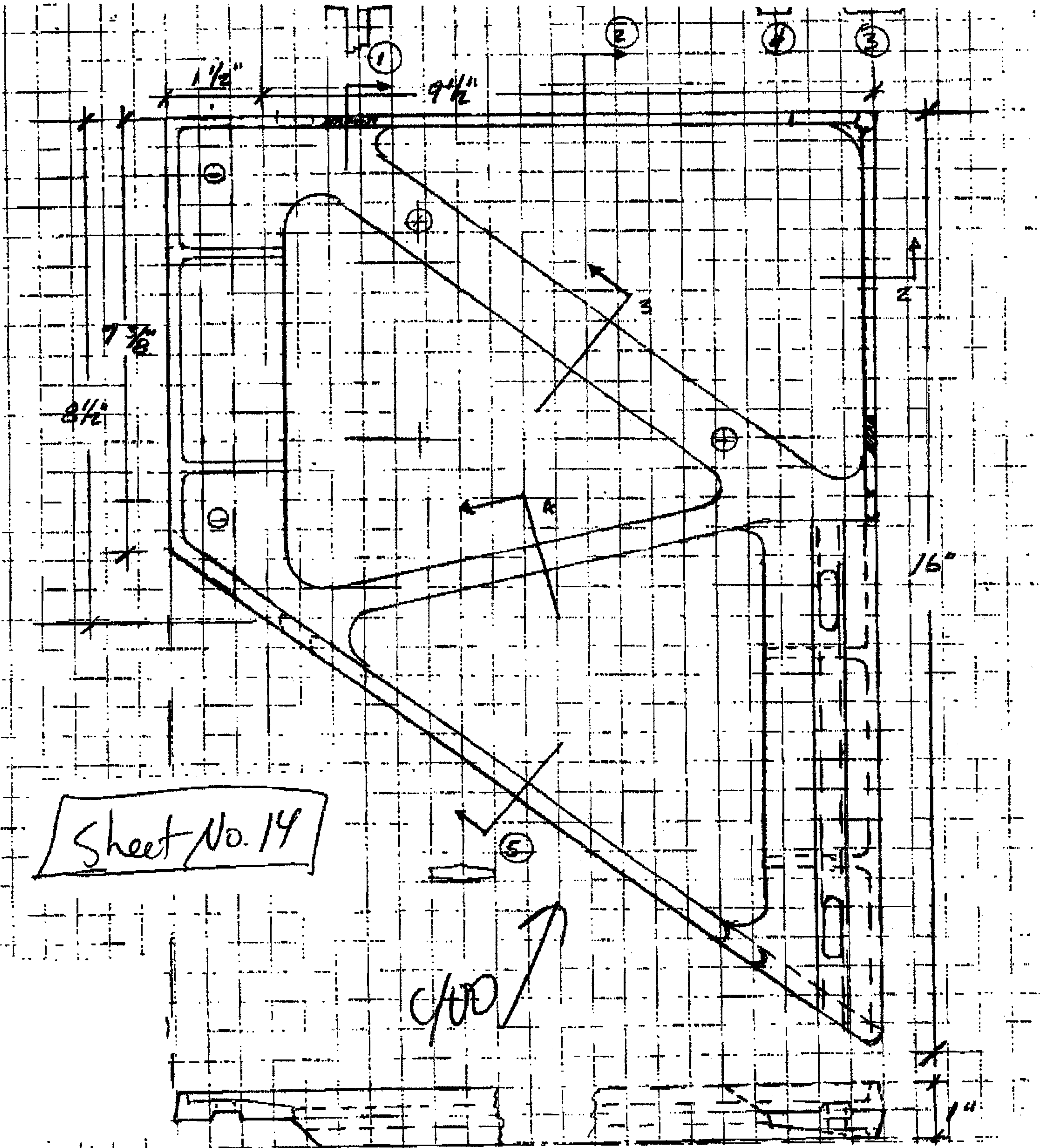

Sheet No. 14

6/00

E.CHELE 1/2

Sheet No. 15

Upper Flooring

Stairway

Lower Flooring

HAUT

STRUCTURE DU PLANCHER (BAS)

150

M, 100, 200, 300, 400, 500, 600

150

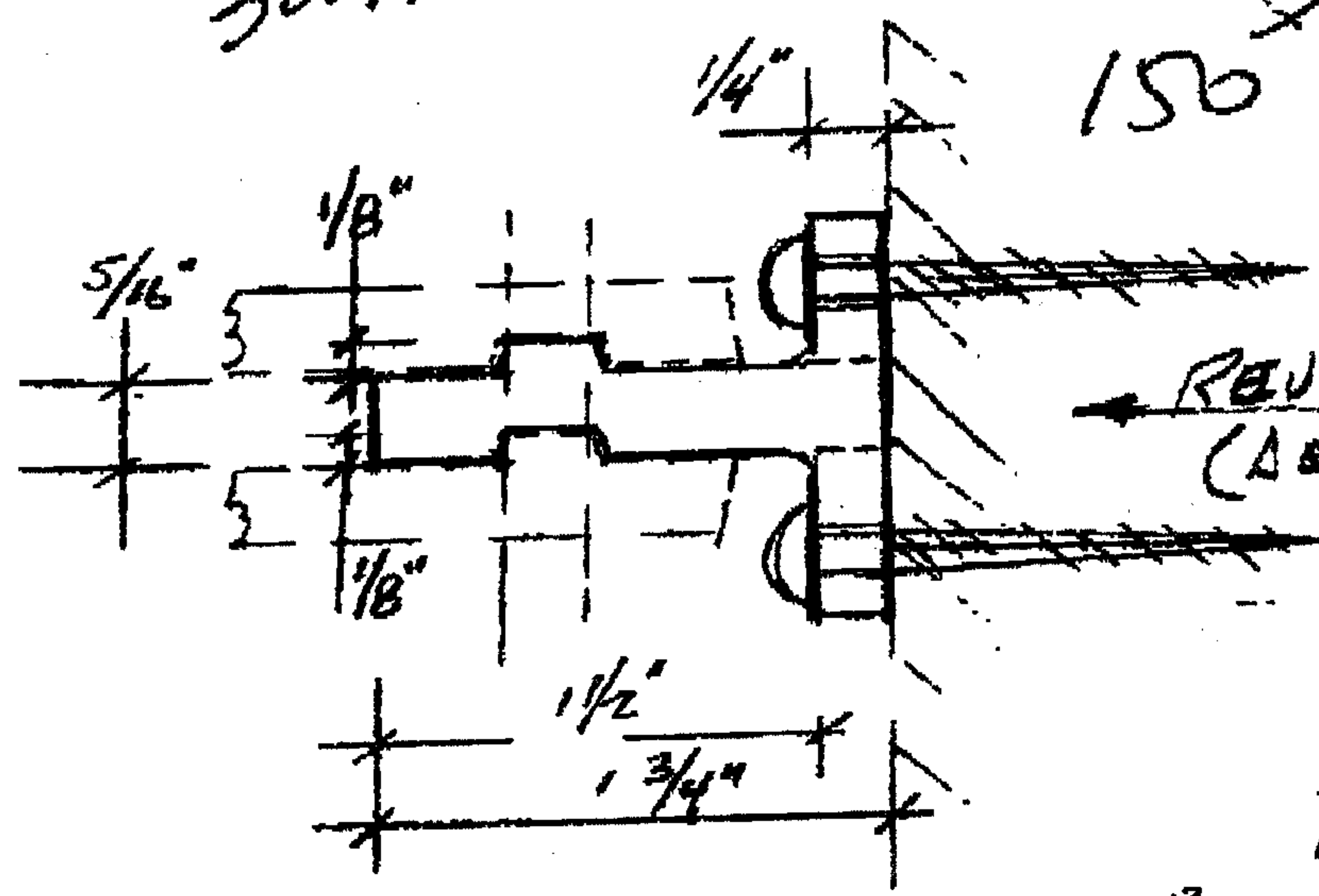

REVISION "1" (DETAIL)

Ferrule is REVERSIBLE & UNIVERSAL

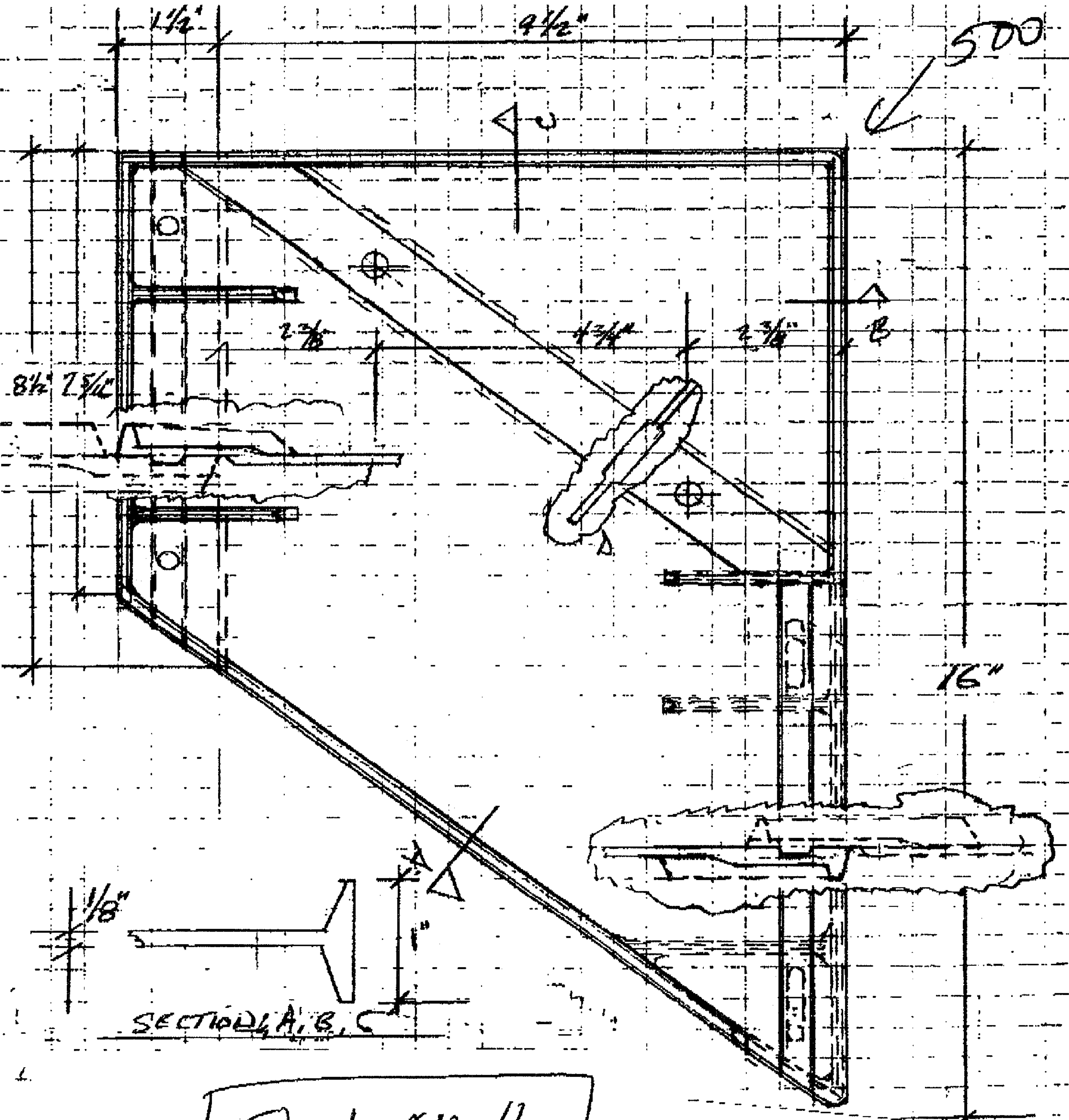

Sheet No. 16

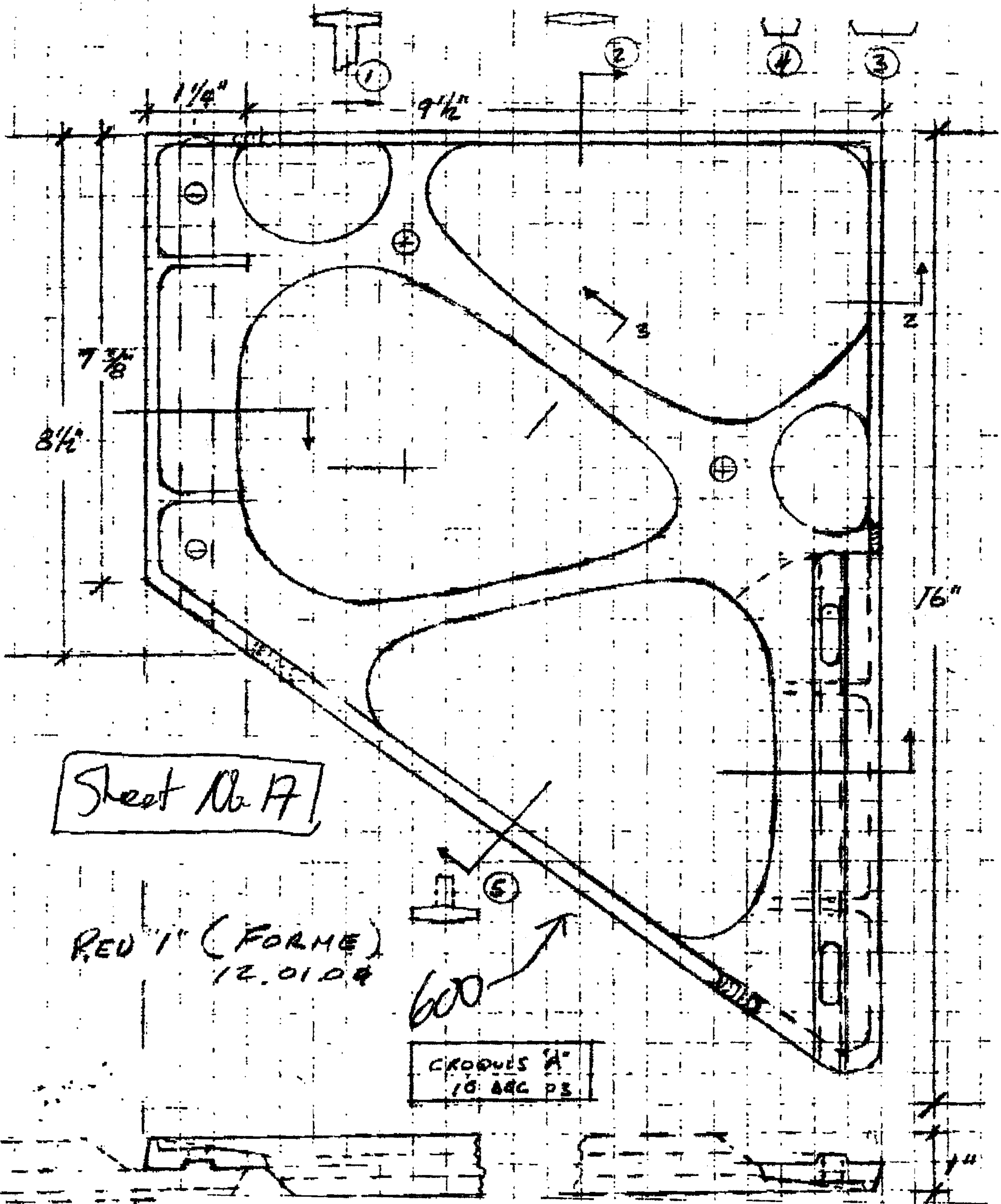

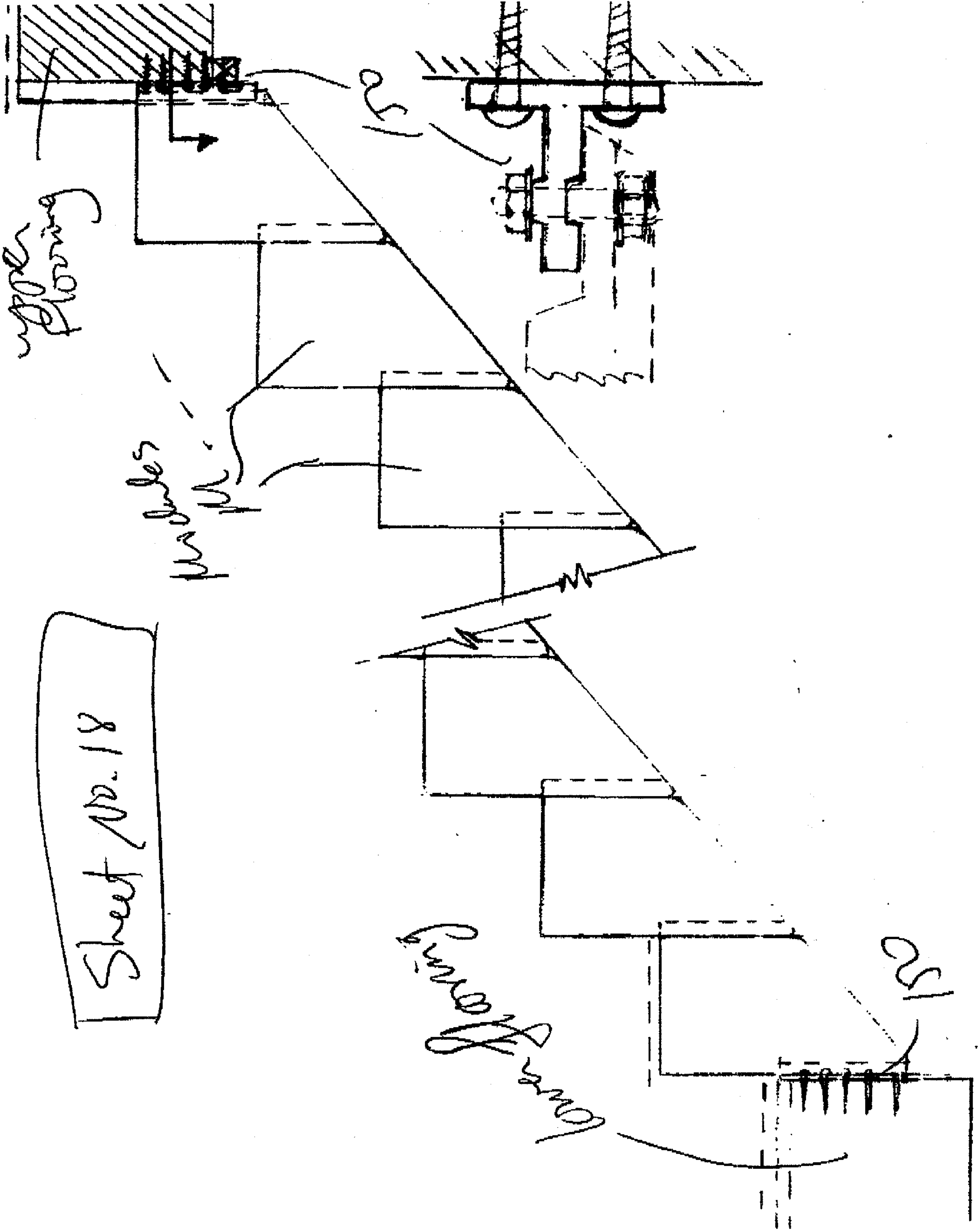

Sheet No. 18

ATTACHE AU PLANCHER
(HAUT & BAS.)

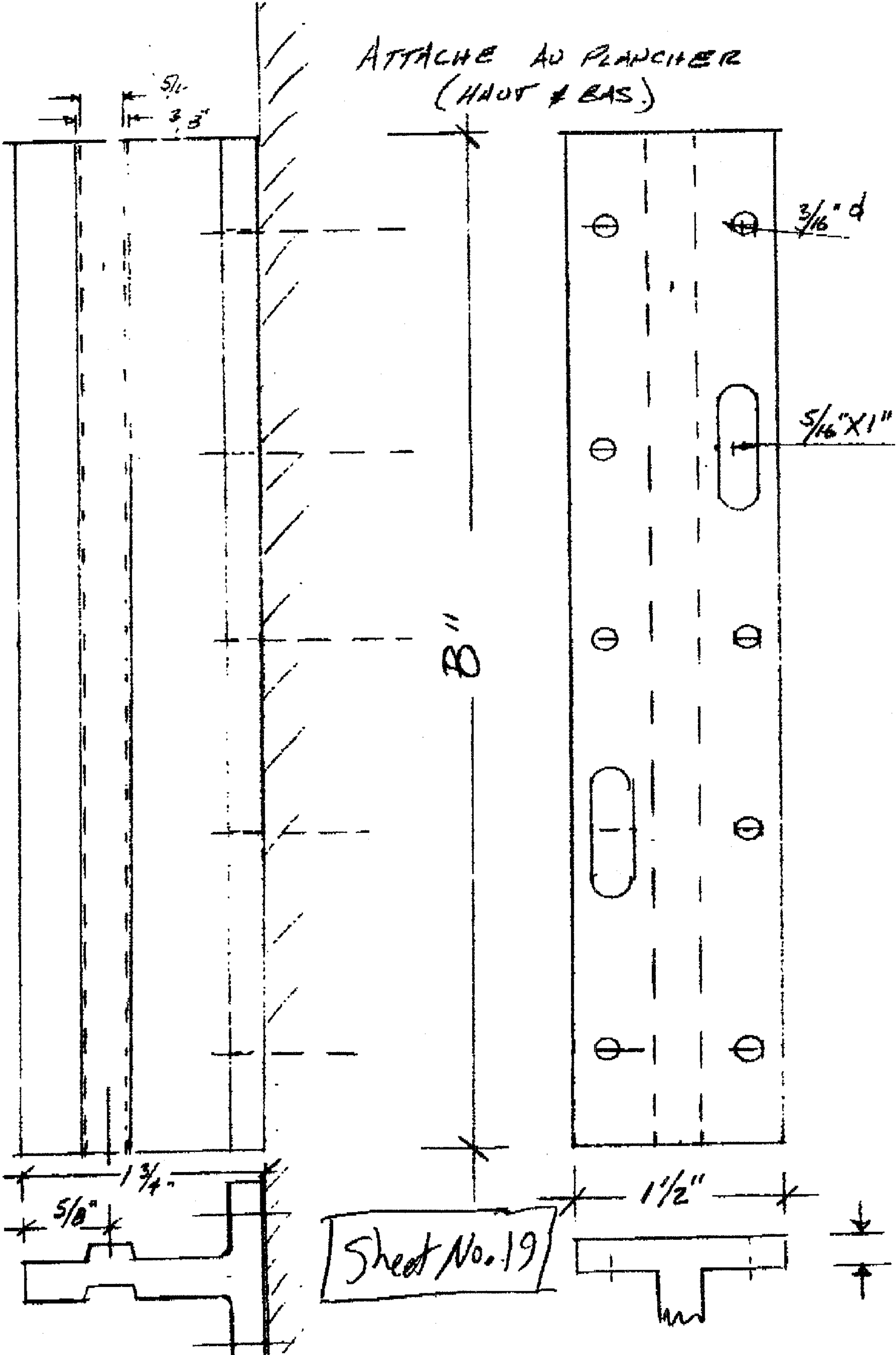

DEMI-COLLERETTE
ATTACHE
HAUT & BAS

Sheet No. 19

1/4"

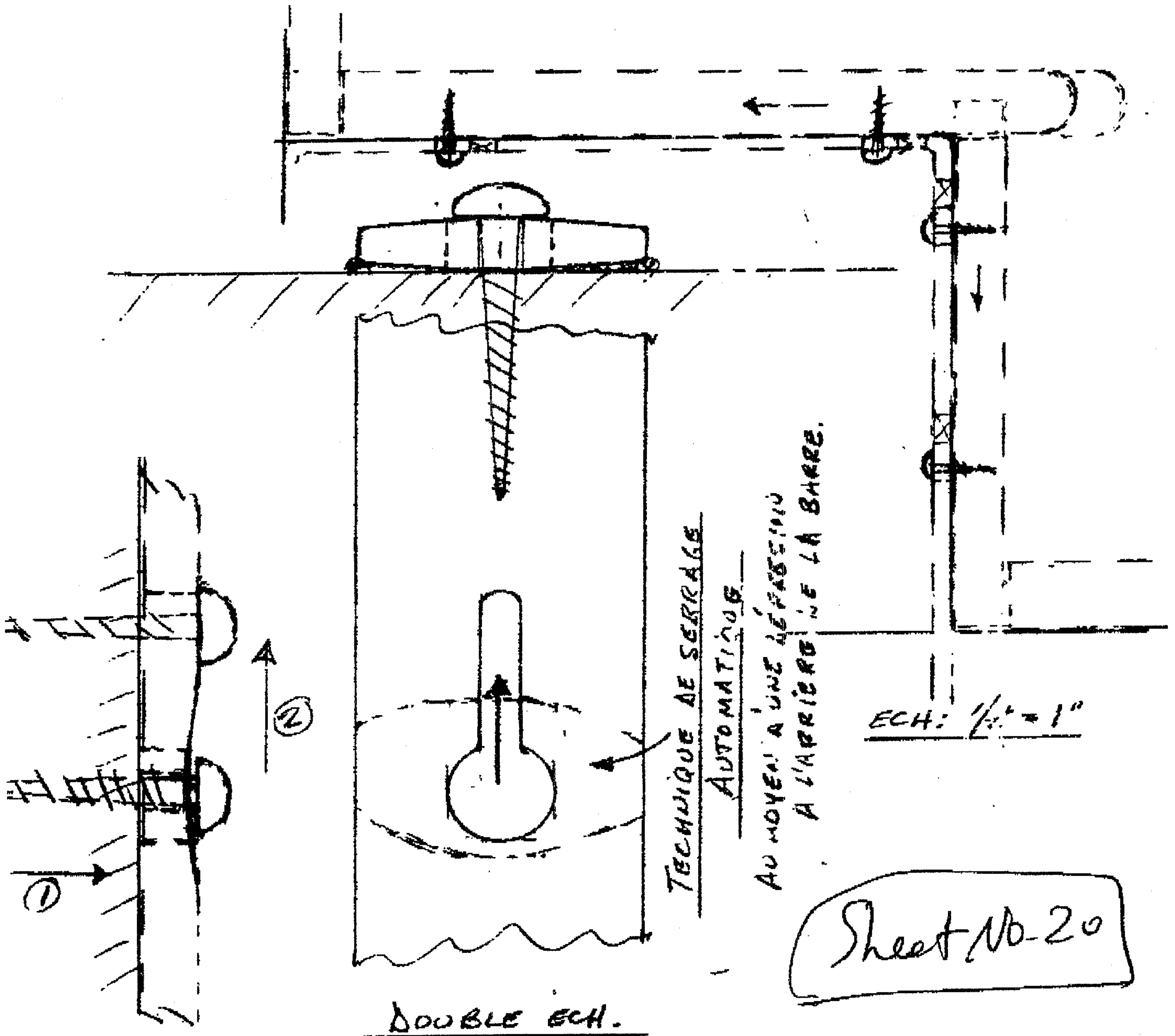

TECHNIQUE D'ATTACHES DISSIMULÉES
DES MARCHES ET CONTRE MARCHES.

LES VIS A BOIS SONT PRE-INSTALLÉS SOUS LE
MARCHÉ À L'ARRIÈRE DE LA C.M.,
LES 2 M.C.M. SONT PRESSES CONTRE LES MARCHES D'ATTACHE
ENSUITE GLISSÉS EN POSITION FINALE.

