

CORRECTED VERSION

(19) World Intellectual Property Organization
International Bureau

(43) International Publication Date
10 September 2020 (10.09.2020)



(10) International Publication Number
WO 2020/178849 A9

- (51) International Patent Classification:
F02D 43/00 (2006.01) *F02P 5/15* (2006.01)
- (21) International Application Number:
PCT/IN2020/050187
- (22) International Filing Date:
28 February 2020 (28.02.2020)
- (25) Filing Language: English
- (26) Publication Language: English
- (30) Priority Data:
201911008022 01 March 2019 (01.03.2019) IN
- (71) Applicant: **HERO MOTOCORP LIMITED** [IN/IN];
The Grand Plaza, Plot No.2, Nelson Mandela Road, Vasant
Kunj- Phase -II, New Delhi 110 070 (IN).
- (72) Inventors: **JAIN, Nitin**; H. No. 1056/20, Civil Road, Near
Malabar Medicare Centre, Rohtak, Haryana - 124001 (IN).
SWAROOP, Gyan; H. No. 4/160, Meharbagh, Sikander-
pur Dayalbagh, Agra – 282005, Uttar Pradesh, (IN).
- (74) Agent: **CHOUBEY, Anand** et al.; K&S PARTNERS In-
tellectual Property Attorneys, 515-B, Platinum Tower, 5th
Floor, Sohna Road, Sector 47, Gurgaon, National Capital
Region 122002 (IN).
- (81) Designated States (*unless otherwise indicated, for every
kind of national protection available*): AE, AG, AL, AM,
AO, AT, AU, AZ, BA, BB, BG, BH, BN, BR, BW, BY, BZ,
CA, CH, CL, CN, CO, CR, CU, CZ, DE, DJ, DK, DM, DO,
DZ, EC, EE, EG, ES, FI, GB, GD, GE, GH, GM, GT, HN,
HR, HU, ID, IL, IN, IR, IS, JO, JP, KE, KG, KH, KN, KP,
KR, KW, KZ, LA, LC, LK, LR, LS, LU, LY, MA, MD, ME,
MG, MK, MN, MW, MX, MY, MZ, NA, NG, NI, NO, NZ,
OM, PA, PE, PG, PH, PL, PT, QA, RO, RS, RU, RW, SA,

(54) Title: CONTROL SYSTEM OF INTERNAL COMBUSTION ENGINE

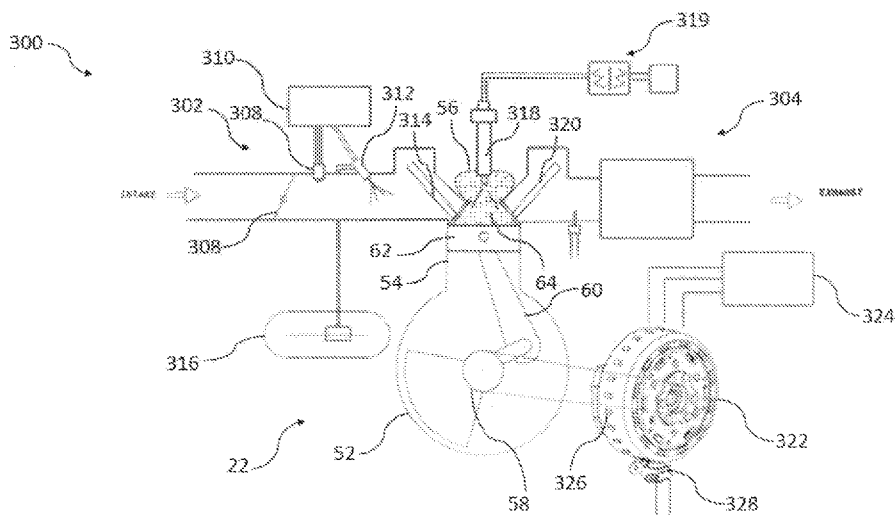

Figure 3

(57) Abstract: A vehicle (10) is provided. The vehicle (10) comprises an internal combustion engine (22) having a combustion chamber (64), a crankshaft (58), an intake manifold (302), a manifold absolute pressure (MAP) sensor (308) to detect pressure within the intake manifold (302), and a crank angle sensor (328) to detect angular position the crank shaft (58). The vehicle (10) also comprises a control system (300) configured to control the engine (22). The control system (300) comprises an electronic control unit (ECU) (310) in electronic communication with the spark plug (318), the MAP sensor (308), the crank angle sensor (328). The ECU (310) is configured to receive an output from each of the MAP sensor (308) and the crank angle sensor (328) and determine rotational direction of the crankshaft (58) based on the output from each of the MAP sensor (308) and the crank angle sensor (328).



WO 2020/178849 A9

SC, SD, SE, SG, SK, SL, ST, SV, SY, TH, TJ, TM, TN, TR,
TT, TZ, UA, UG, US, UZ, VC, VN, WS, ZA, ZM, ZW.

- (84) Designated States** (*unless otherwise indicated, for every kind of regional protection available*): ARIPO (BW, GH, GM, KE, LR, LS, MW, MZ, NA, RW, SD, SL, ST, SZ, TZ, UG, ZM, ZW), Eurasian (AM, AZ, BY, KG, KZ, RU, TJ, TM), European (AL, AT, BE, BG, CH, CY, CZ, DE, DK, EE, ES, FI, FR, GB, GR, HR, HU, IE, IS, IT, LT, LU, LV, MC, MK, MT, NL, NO, PL, PT, RO, RS, SE, SI, SK, SM, TR), OAPI (BF, BJ, CF, CG, CI, CM, GA, GN, GQ, GW, KM, ML, MR, NE, SN, TD, TG).

Declarations under Rule 4.17:

- *as to applicant's entitlement to apply for and be granted a patent (Rule 4.17(ii))*

Published:

- *with international search report (Art. 21(3))*
- *in black and white; the international application as filed contained color or greyscale and is available for download from PATENTSCOPE*

(48) Date of publication of this corrected version:

24 March 2022 (24.03.2022)

(15) Information about Correction:

see Notice of 24 March 2022 (24.03.2022)

CONTROL SYSTEM OF INTERNAL COMBUSTION ENGINE

FIELD OF INVENTION

[0001] The present invention relates to internal combustion engines and, more particularly, to a control system for an internal combustion engine.

5

BACKGROUND

[0002] In the interest of improving the efficiency and emission related performance of internal combustion engines, direct cylinder injection systems have evolved. By injecting fuel directly into the combustion chamber or inlet manifold of the internal combustion engine, a number of advantages can be accomplished. One of these advantages is the ability to run the engine on less than stoichiometric mixture.

10

[0003] In various types of engines, for example, in single cylinder internal combustion engines, the ignition systems are controlled by a control unit. The control unit controls movement of the crank shaft and firing of the ignition system. As such, the control unit controls the movement of the crank shaft and the firing of the ignition system, such that the ignition system is caused to fire during forward rotation of the crank shaft, i.e., when piston is moving from TDC to BDC. The control unit also ensures that the ignition from the ignition system is resisted during the period of reverse rotation of the crank shaft, i.e., when piston is moving from BDC to TDC.

15

[0004] However, in certain types of engines, for example, where the control unit controls the ignition system, whereas a separate controller, such as an ISG ACG controller, controls the movement of the crank shaft, it often becomes difficult to ensure that the ignition from the ignition system is resisted during the period of reverse rotation of the crank shaft.

20

SUMMARY

[0005] In one aspect of the present invention, a vehicle is provided. The vehicle comprises an internal combustion engine and a control system. The internal combustion engine comprises a combustion chamber defined by a cylinder head and a crankcase. The internal combustion engine also comprises a crankshaft disposed within the crankcase. The internal

25

combustion engine further comprises a spark plug positioned within the combustion chamber for firing a charge therein. The internal combustion engine comprises an intake manifold and an exhaust manifold fluidically coupled to the combustion chamber. The internal combustion engine further comprises an rotary electric machine configured to, at a time of engine start, act as a starter motor that causes a crankshaft of an internal combustion engine to rotate. The internal combustion engine comprises a manifold absolute pressure sensor disposed within the intake manifold. The MAP sensor is configured to detect pressure within the intake manifold. The internal combustion engine also comprises a crank angle sensor provided with the ISG. The crank angle sensor is configured to detect angular position and engine rpm of the crankshaft of the internal combustion engine. The control system configured to control the internal combustion engine. The control system comprises an electronic control unit in electronic communication with the MAP sensor, the crank angle sensor. The electronic control unit is configured to receive an output from each of the MAP sensor and the crank angle sensor, to determine rotational direction of the crank shaft based on the output from each of the MAP sensor and the crank angle sensor.

[0006] In an embodiment, the electronic control unit is further configured to selectively allow and restrict firing of the spark plug in response to determination of the rotational direction of the crank shaft. In an embodiment, the rotary electric machine is mounted on the crankshaft and comprises at least one reference tooth, wherein the at least one reference tooth is indicative of a predetermined position on the crank shaft and a plurality of teeth positioned angularly along circumference of the rotary electric machine. Each teeth of the plurality of teeth from the reference tooth indicates predetermined angular positions of the crank shaft.

[0007] In an embodiment, the reference tooth has a predetermined profile or is in form of absence of a tooth. In an embodiment, the MAP sensor generates a voltage signal in response to the sensed pressure in the intake manifold and the crank angle sensor generates a voltage signal indicative of the angular position of the crank shaft. The voltage signal generated by the MAP sensor and the crank angle sensor are communicated to the electronic control unit.

[0008] In an embodiment, the crankshaft is rotating in first rotational direction (D1) if the voltage generated by the MAP sensor at the predetermined timing of the PIP signal is above a predetermined threshold value stored within the electronic control unit. In an embodiment the crank angle sensor generates a profile ignition pickup (PIP) signal indicative of the angular position of the crank shaft.

[0009] In an embodiment the rotational direction of the crank shaft is determined by the electronic control unit based on the voltage signal of the MAP sensor at a predetermined angular position of the crank shaft. In an embodiment, the predetermined angular position of the crank shaft is the first tooth of plurality of teeth after the reference tooth. In an embodiment the crank shaft is rotating in first rotational direction (D1) if the voltage generated by the MAP sensor at the predetermined angular position of the crankshaft is above a predetermined threshold value stored in the electronic control unit.

[00010] In an embodiment the crank shaft is rotating in second rotational direction (D2) if the voltage generated by the MAP sensor at the predetermined angular position of the crankshaft is below a predetermined threshold value stored in the electronic control unit. In an embodiment, the first rotational direction (D1) is reverse direction and the second rotational direction (D2) is forward direction. In an embodiment the rotary electric machine is integrated starter generator (ISG). In an embodiment the crank angle sensor is a pulsar coil. In an embodiment the crank angle sensor is a Hall Effect sensor. In an embodiment the electronic control unit (ECU) does not allow firing of the spark plug till it determines the rotational direction of the crankshaft.

[00011] In an embodiment the rotational direction of the crank shaft is determined by the electronic control unit based on first voltage signal of the MAP sensor at a first predetermined angular position of the crank shaft and a second voltage signal of the MAP sensor at a second predetermined angular position of the crank shaft.

[00012] In an embodiment the crank shaft is rotating in first rotational direction (D1) if the first voltage generated by the MAP sensor at the first predetermined angular position of the crankshaft and the second voltage generated by the MAP sensor at the second predetermined angular position of the crankshaft is above a predetermined threshold value stored in the electronic control unit; and the crank shaft is rotating in

second rotational direction if the first voltage generated by the MAP sensor at the first predetermined angular position of the crankshaft and the second voltage generated by the MAP sensor at the second predetermined angular position of the crankshaft is below a predetermined threshold value stored in the electronic control unit.

5 [00013] In another aspect of the present invention, a method of controlling an internal combustion engine by a control system is provided. The method comprises sensing air pressure in an intake manifold via a manifold absolute pressure (MAP) sensor; generating a MAP voltage signal representative of the sensed air pressure; sensing angular position of a crank shaft of the internal combustion engine via a crank angle
10 sensor; generating a voltage signal representative of the angular position of the crank shaft; and determining rotational direction of the crank shaft by an electronic control unit, based on the generated MAP voltage signal at a predetermined position of the crank shaft.

[00014] In an embodiment, the electronic control unit controls the sparking of the
15 spark plug based on the determined rotational direction of the crank shaft. In an embodiment, the crank shaft is rotating in first rotational direction (D1) if the voltage generated by the MAP sensor at the predetermined position of the crankshaft is above a predetermined threshold value stored in the electronic control unit, wherein the electronic control unit restricts the sparking of the spark plug, when first rotational direction (D1)
20 rotation of the crank shaft is determined.

[00015] In an embodiment, the crank shaft is rotating in second rotational direction (D2) if the voltage generated by the MAP sensor at the predetermined position of the crankshaft is below a predetermined threshold value stored within the electronic control unit, wherein the electronic control unit allows the sparking of the spark plug, when
25 second rotational direction (D2) rotation of the crank shaft is determined.

BRIEF DESCRIPTION OF DRAWINGS

[00016] The invention itself, together with further features and attended advantages, will become apparent from consideration of the following detailed description, taken in conjunction with the accompanying drawings. One or more embodiments of the present

invention are now described, by way of example only wherein like reference numerals represent like elements and in which:

[00017] Figure 1 illustrates a side view of an exemplary two-wheeled vehicle, according to an embodiment of the present invention;

5 [00018] Figure 2 illustrates a perspective view of a frame of the exemplary two-wheeled vehicle, in accordance with an embodiment of the present invention;

[00019] Figure 3 illustrates a schematic view of a control system and an internal combustion engine of a vehicle, in accordance with an embodiment of the present invention;

10 [00020] Figure 4 illustrates a graph of parameters of the internal combustion engine, in accordance with an embodiment of the present invention;

[00021] Figure 5 illustrates a graph of parameters of the internal combustion engine, in accordance with an embodiment of the present invention;

15 [00022] Figure 6 illustrates a method of controlling the internal combustion engine by the control system, according to an embodiment of the present invention.

[00023] The drawings referred to in this description are not to be understood as being drawn to scale except if specifically noted, and such drawings are only exemplary in nature.

DETAILED DESCRIPTION

20 [00024] While the invention is susceptible to various modifications and alternative forms, an embodiment thereof has been shown by way of example in the drawings and will be described here below. It should be understood, however that it is not intended to limit the invention to the particular forms disclosed, but on the contrary, the invention is to cover all modifications, equivalents, and alternative falling within the spirit and the
25 scope of the invention.

[00025] The term “comprises”, comprising, or any other variations thereof, are intended to cover a non-exclusive inclusion, such that a setup, structure or method that comprises a list of components or steps does not include only those components or steps but may include other components or steps not expressly listed or inherent to such setup or structure or method. In other words, one or more elements in a system or apparatus preceded by “comprises... a” does not, without more constraints, preclude the existence of other elements or additional elements in the system or apparatus.

[00026] For better understanding of this invention, reference would now be made to the embodiment illustrated in the accompanying Figures and description here below, further, in the following Figures, the same reference numerals are used to identify the same components in various views.

[00027] In one aspect of the present invention, a control system of an internal combustion engine is illustrated. The internal combustion engine includes at least one combustion chamber, an inlet manifold communicating to the combustion chamber, a fuel injector for injecting fuel directly into the combustion chamber, and at least one spark plug positioned on the combustion chamber for firing a charge therein. The control system includes a MAP sensor disposed on the inlet manifold, the MAP sensor being configured to measure the inlet manifold pressure; a crank angle sensor configured to determine a position of a crank shaft of the internal combustion engine; a control module adapted to receive output from each of the MAP sensor and the crank angle sensor to determine a reverse rotation of the crank shaft.; and an ignition system interfaced with the control module and the spark plug, wherein the control system restricts firing of the spark plug by ignition system during reverse rotation of the crank shaft.

[00028] While the present invention is illustrated in the context of a vehicle, however, control system & internal combustion engine and aspects and features thereof can be used with other type of vehicles as well. The terms “vehicle”, “two-wheeled vehicle” and “motorcycle” have been interchangeably used throughout the description. The term “vehicle” comprises vehicles such as motorcycles, scooters, bicycles, mopeds, scooter type vehicle, All-Terrain Vehicles (ATV) and the like.

[00029] The terms “front / forward”, “rear / rearward / back / backward”, “up / upper / top”, “down / lower / lower ward / downward, bottom”, “left / leftward”, “right / rightward” used therein represents the directions as seen from a vehicle driver sitting astride and these directions are referred by arrows Fr, Rr, U, Lr, L, R in the Figures.

5 [00030] Referring to Figures 1, a vehicle (10) according to an embodiment of the present invention is illustrated. The vehicle (10) referred to herein, embodies a two wheeled motorcycle. Alternatively, the vehicle (10) may embody any other ridden vehicles such as scooters, three-wheeled vehicles, All-Terrain Vehicles (ATV) etc. without limiting the scope of the invention.

10 [00031] The vehicle (10) comprises one or more body parts, such as a frame (12), a handle bar (14), a front wheel (16), a seat (18), a rear wheel (20), an internal combustion engine (22), a headlight (24), and a fuel tank (26). The frame (12) supports the internal combustion engine (22) (herein after alternatively referred to as engine (22)) in middle portion of the vehicle (10). In the illustrated example, the engine (22) provides necessary
15 power required to drive the rear wheel (20) of the vehicle (10). Alternatively, the engine (22) may provide necessary power to the drive the front wheel (16), or both the front wheel (16) and the rear wheel (20) simultaneously, without limiting the scope of the invention. The rear wheel (20) is linked to the engine (22) through a transmission mechanism (not numbered).

20 [00032] The frame (12) supports the seat (18) which extends from middle portion towards a rear portion (28) of the vehicle (10). The seat (18) provides seating for a rider and / or a passenger of the vehicle (10). The fuel tank (26) provides necessary fuel to the engine (22) to generate power within the vehicle (10).

[00033] As shown in Figure 2, the frame (12) of the vehicle (10) comprises the head
25 pipe (30), a main frame (32), and a down frame (34). The main frame (32) extends downwards and rearwards from a rear portion of the head pipe (30) so as to form a relatively mild slope in side view. The down frame (34) extend downward and rearward in a manner branching into left and right, respectively, so as to form a relatively steep slope in side view. The frame (12) comprises a pair of lower frames (36). The pair of

lower frames (36) are curved to extend rearwardly from lower ends of the down frame (34).

[00034] Further, the frame (12) comprises a pair of middle frames (38). The pair of middle frames (38) extend downward and rearward from a main frame cross bar (40).
5 The frame (12) comprises a mount bracket (42) coupled to the front side of lower portions of the pair of middle frames (38). Further, the frame (12) further comprises a pair of sub frame members (50). In an embodiment, the pair of sub frame members (50) are embodied as a pair of seat frames are disposed rearward of the upper ends of the pair of respective middle frames (38). The frame (12) also supports the engine (22).

10 [00035] As shown in Figure. 3, a system (300), also referred to as a control system (300) for controlling the engine (22) is illustrated. The engine (22), also interchangeably referred to as “internal combustion engine (22),” includes a crank case (52), a cylinder (54) connected to the crank case (52) and a head portion (56) (also referred to as cylinder head (56)) connected to the crank case (52). In alternative embodiments of the present
15 disclosure, the internal combustion engine (22) includes a multitude of cylinders, such as the cylinder (54), positioned in-line or at an angle with respect to one another. The crank case (52) encloses a crank shaft (58) which is connected to a connecting rod (60). The connecting rod (60) is connected to a piston (62) enclosed within the cylinder (54). The piston (62) is configured to move within the cylinder (54) causing the crank shaft (58) to
20 rotate. As such, the piston (62) moved between a TDC (Top Dead Center) position and a BDC (Bottom Dead Center) position thereof, to rotate the crank shaft (58) along its rotational axis (not illustrated). Alternatively, where the internal combustion engine (22) includes a plurality of cylinders, there may be plurality of pistons, such as the piston (62), reciprocating within the respective plurality of cylinders, and connected to the crank shaft
25 (58).

[00036] In an embodiment, the internal combustion engine (22) includes an inlet portion (302) and an exhaust portion (304), mounted on the cylinder (54). Specifically, the inlet portion (302), also referred to as “inlet manifold (302)” and the exhaust portion (304) also referred to as “exhaust manifold (304)” is connected to a top portion of the

cylinder (54), i.e., the head portion (56). The inlet manifold (302) and the exhaust manifold (304) are fluidically coupled to the combustion chamber (64).

[00037] As illustrated in Figure. 3, the internal combustion engine (22) further includes a butterfly valve (306), a MAP sensor (308), a fuel injector (312) and an inlet valve (314). The inlet portion (302) defines a channel extending up to the cylinder (54) of the internal combustion engine (22). The channel defined by the inlet portion (302) opens into a combustion chamber (64), via the inlet valve (314). The butterfly valve (306) is positioned within the inlet portion (302). The butterfly valve (306), through its open and closed position, allows and restricts entry of air. As such, the butterfly valve (306) in the open position allows the entry of air, and in the closed position restricts entry of air. In the illustrated example, the control system (300) comprises an Electronic Control Unit (ECU) (310). In another example, the internal combustion engine (22) comprises an Electronic Control Unit (ECU) (310) and is electronically and electrically coupled to the control system (300) of the vehicle (100), without any limitations.

[00038] The MAP sensor (308), also referred to as “Manifold Absolute Pressure sensor (308),” is positioned onto the channel defined by the inlet portion (302). The MAP sensor (308) is electrically coupled to the ECU (310). In an embodiment, the MAP sensor (308), includes a probe (not numbered) positioned within the inlet portion (302), a sensor voltage output connector (not numbered) extending from the probe to the ECU (310), a ground connector (not numbered) extending from the probe to the ECU (310) and a power supply connector (not numbered), extending from the probe to the ECU (310).

[00039] The MAP sensor (308) generates a voltage signal in response to the sensed pressure within the intake manifold (302). More particularly, the probe of the MAP sensor (308) is adapted to measure pressure within the inlet portion (302), and provide a corresponding output to the ECU (310). In an embodiment, the probe of the MAP sensor (308) is adapted to measure pressure within the inlet portion (302), and provide a corresponding voltage output to the ECU (310). The fuel injector (312) positioned adjacent to the MAP sensor (308) is connected to a fuel pump (not shown) and a fuel filter (316). The fuel injector (312) supplies fuel to the inlet portion (302), from the fuel pump and fuel filter (316), when commended by the ECU (310). Therefore, the fuel

injector (312) is interfaced with the ECU (310). The inlet valve (314) is positioned upstream of the fuel injector (312), and also the butterfly valve (306). The inlet valve (314) selectively opens into the combustion chamber (64). When the inlet valve (314) is open, intake from the butterfly valve (308), and the fuel injector (312) is allowed to enter the combustion chamber (64). Likewise, when the inlet valve (314) is closed, the intake from the butterfly valve (308), and the fuel injector (312) is disallowed from entering the combustion chamber (64).

[00040] As would be apparent to those skilled in the art, when the intake, also referred to as “charge,” is received into the combustion chamber (64), and when a spark plug (318) creates a spark, which is caused by an ignition system (319) controlled by a controller, or the ECU (310), the ignition of the charge takes place, within the combustion chamber (64). The ignition of the charge within the combustion chamber (64), causes the piston to move back, and subsequently burnt gases are expelled from the combustion chamber (64), via an exhaust valve (320) positioned within the exhaust portion (304) of the internal combustion engine (22). In an embodiment, an O₂ sensor (not numbered) is provided on the exhaust portion (304), adjacent to the exhaust valve (320).

[00041] As shown in Figure. 3, the internal combustion engine (22) further includes a rotary electric machine (322). In an example, the rotary electric machine may be an Integrated Starter Generator (ISG) (322). In an embodiment, the Integrated Starter Generator (322) may be an ISG ACG. In particular, the Integrated Starter Generator (322) is connected to the crank shaft (58) of the internal combustion engine (22). The Integrated Starter Generator (322) is in communication with an ISG controller (324). The ISG controller (324), is adapted to operate the Integrated Starter Generator (322), i.e., adapted to cause the Integrated Starter Generator (322) to function interchangeably as a starter or a generator. It may be apparent to those skilled in that art that while operating as the generator, the Integrated Starter Generator (322) receives power from the crank shaft (58) of the internal combustion engine (22), and generates electrical energy. On the other hand, while working as the starter, the Integrated Starter Generator (322) provides rotational movement to the crank shaft (58), to facilitate combustion within the combustion chamber (64) of the internal combustion engine (22).

[00042] The internal combustion engine (22) further includes a pulsar wheel (not shown) having a plurality of teeth (326) (herein after alternatively referred to as PIPs (326)). In the illustrated example, the pulsar wheel having the plurality of teeth (326) is disposed on the ISG (322). In another example, the pulsar wheel having the plurality of teeth (326) are disposed on the crank shaft (58), without limiting the scope of the invention. The plurality of teeth (326) of the Integrated Starter Generator (322), in an example, are embodied as a predefined number of metallic projections provided in an equally spaced apart manner on an external peripheral surface of the Integrated Starter Generator (322). The plurality of teeth (326) are equally spaced apart angularly along circumference of the pulsar wheel. The pulsar wheel comprises a missing tooth in the areas of greater angular separation between the plurality of teeth (326). In an alternative embodiment, the missing tooth is embodied as a reference tooth. The missing tooth is indicative of a predetermined position on the crank shaft (58) and each the teeth of the plurality of teeth (326) positioned from the missing tooth indicates various predetermined angular positions of the crank shaft (58). In an example, the predefined number of metallic projections on an external peripheral surface of the Integrated Starter Generator (322) are “18 – 1” in number. Therefore, in such an embodiment, there are 17 teeth, followed by a gap, i.e., a missing tooth. In another example, the predefined number of metallic projections on an external peripheral surface of the Integrated Starter Generator (322) are “22 – 1,” in number. Therefore, in such an embodiment, there are 21 teeth, followed by a gap, i.e., the missing tooth. The internal combustion engine (22) further includes a sensor (328) for measuring position of crank shaft (58). In an embodiment, the sensor (328) for measuring position of the crank shaft (58) may be a crank angle sensor.

[00043] In an embodiment, the sensor (328) for measuring position of crank shaft (58) is positioned on the external peripheral surface of the Integrated Starter Generator (322). The sensor (328) is positioned on the external peripheral surface of the Integrated Starter Generator (322) such that the sensor (328) senses every time a pip passes from its vicinity and accordingly generates a pulse. Similarly, every time the gap passes from the vicinity of the sensor (328), the pulse is not generated. Therefore, in an embodiment where the predefined number of metallic projections on an external peripheral surface of the Integrated Starter Generator (322) are “18 – 1” in number, during movement of the

Integrated Starter Generator (322), the sensor (328) generates 17 pulses followed by a gap with every complete rotation of the Integrated Starter Generator (322). It may herein be noted that the sensor (328) is configured to generate pulses irrespective of direction of rotation of Integrated Starter Generator (322), being in a first rotational direction (D1) or a second rotational direction (D2). In the illustrated example, the first rotational direction (D1) is reverse direction and the second rotational direction (D2) is forward direction. In the illustrated example, the forward and reverse directions may be clockwise or counter clockwise directions, according to requirements and engine configurations.

[00044] The sensor (328) is electrically connected to the ECU (310). Owing to such connectional of the sensor (328) with the ECU (310), the measurements of pulses and lack thereof, is communicated to the ECU (310). In an embodiment, the sensor (328) for measuring the position of the crank shaft (58) of the engine (22) may be a pulsar coil. Alternatively, the sensor (328) for measuring the position of the crank shaft (58) of the engine (22) may be a HAL effect sensor, also known as HAL sensor.

[00045] As illustrated in Figure. 3, the control system (300) includes the MAP sensor (308), the crank angle sensor (328), and the ECU (310) in communication with each of the MAP sensor (308), and the crank angle sensor (328). Therefore, the ECU (310), also referred to as a control module (310) is configured to receive inputs pertaining to pressure at the intake portion (302), as measured by the MAP sensor (308). Likewise, the control module (310) is configured to receive inputs pertaining to angular position of the crank shaft (58), as measured by the crank angle sensor (328). The MAP sensor (308) generates a voltage signal in response to the sensed pressure within the intake manifold (302) and the crank angle sensor (328) generates a profile ignition pickup (PIP) signal indicative of the angular position of the crank shaft (58). The voltage signal generated by the MAP sensor (308) and the PIP signal are communicated to the electronic control unit (310).

[00046] Referring now to Figure. 4 and Figure. 5, graphs showing values of output from the MAP sensor (308), and the output from the crank angle sensor (328), are illustrated. The output from the MAP sensor (308) is directly proportional to absolute pressure of intake manifold (302). Therefore, the output from the MAP sensor (308) is indicative of the absolute pressure of the intake manifold (302). As shown in Figure. 4

and Figure. 5, a MAP sensor output line (330), indicates the MAP sensor voltage. When the vehicle (10) is turned on and operated, the pressure at the intake manifold (302) changes, and accordingly the output of the MAP sensor (308), as indicated by the MAP sensor output line (330), also changes.

5 **[00047]** The control module (310) is interfaced with the MAP sensor (308) to receive the output thereof to ascertain when the voltage, and thus the pressure, at the intake manifold (302) is above a predetermined threshold value. In another embodiment, the control module (310) is adapted to ascertain when the pressure at the inlet manifold is below the predetermined threshold value. In yet another embodiment, the control module
10 (310) is adapted to ascertain when the pressure at the inlet manifold is within a predetermined threshold range. In an example, the control module (310) is adapted to ascertain that the voltage corresponding to pressure at the inlet manifold (302) is above 2.77 volts.

[00048] The output of the crank angle sensor (328) is in the form of pulses and is
15 indicated by a crank sensor pulse line (332), illustrated in Figure. 4, and Figure. 5. When the vehicle (10) is turned on and operated, the position of the crank shaft (58) changes, and the crank angle sensor (328), senses every time the pip passes from its vicinity and accordingly generates a pulse. Similarly, every time the gap passes from the vicinity of the sensor (328), the pulse is not generated. The control module (310) is also interfaced
20 with the crank angle sensor (328) to receive the output thereof. Based on the output of the crank angle sensor (328), and the MAP sensor (308), the control module (310) determines direction of rotation of the crank shaft (58). More particularly, the rotational direction of the crank shaft (58) is determined by the electronic control unit (310) based on the voltage signal generated by the MAP sensor (308) at any predetermined timing
25 related to the PIP signal indicative of the angular position of the crank angle sensor (328). The control module (310) determines that the crank shaft (58) is rotating in first rotational direction (D1) if the voltage generated by the MAP sensor (308) at the predetermined timing of the PIP signal is above a predetermined threshold value stored within the electronic control unit (310). The control module (310) determines that the crank shaft
30 (58) is rotating in second rotational direction (D2) if the voltage generated by the MAP

sensor (308) at the predetermined timing of the PIP signal is below a predetermined threshold value stored within the electronic control unit (310). The predetermined timing of the PIP signal is selected from any one of the predetermined angular positions of the crank shaft (58), wherein the angular position of crank shaft (58) is indicated by the plurality of teeth (326).

5

[00049] In an embodiment, based on the output of the crank angle sensor (328), and the MAP sensor (308), the control module (310) determines reverse rotation of the crank shaft (58). The control module (310) being also interfaced with the injection system, is adapted to restricts firing of the spark plug (318) by ignition system (319) during reverse rotation of the crank shaft (58).

10

[00050] In an embodiment, the control module (310) determines that the direction of rotation of the crank shaft (58) is forward direction, when the output from the MAP sensor (308) is above a predetermined threshold, and a gap in pulses of output of the crank angle sensor (328) is sensed. For example, when the control module (310) senses that the output from the MAP sensor (308) is above about 2.77 Volts, and the first pulse after the gap, is sensed by the crank angle sensor (328), the control module (310) ascertains that the crank shaft (58) is undergoing a reverse rotation. In other examples, the control module (310) ascertains, if $\text{ADC Value @ First Pip} < \text{Reference Voltage}$ (say 2.5 V), that the engine (22) is rotating in forward motion, and if $\text{ADC Value @ First Pip} > \text{Reference Voltage}$, then the engine (22) is rotating in reverse motion.

15

20

[00051] Referring to Figure 6, a method (400) of controlling the internal combustion engine by the control system (300) is depicted. At step 402, the MAP sensor (308) senses air pressure within the intake manifold (322). At step 404, the MAP sensor (308) generates a MAP voltage signal (330) representative of the sensed air pressure. At step 406, the crank angle sensor (328) senses angular position of the crank shaft (58). At step 408, the crank angle sensor (328) generates a profile ignition pickup signal (332) representative of angular position of the crank shaft (58). At step 410, the ECU (310) determines the rotational direction of the crank shaft (58) based on the generated MAP voltage signal (330) and the profile ignition pickup signal (322) at a predetermined time.

25

[00052] The electronic control unit (310) controls the sparking of the spark plug (318) based on the determined rotation of the crank shaft (58). The crank shaft (58) is rotating in first rotational direction (D1) if the voltage generated by the MAP sensor (308) at the predetermined timing of the PIP signal (332) is above a predetermined threshold value stored within the electronic control unit (310), wherein electronic control unit (310) restricts the sparking of the spark plug (318), when first rotational direction (D1) rotation of the crank shaft (58) is determined. The crank shaft (58) is rotating in second rotational direction (D2) if the voltage generated by the MAP sensor (308) at the predetermined timing of the PIP signal (332) is below a predetermined threshold value stored within the electronic control unit (310). The electronic control unit (310) allows the sparking of the spark plug (318), when second rotational direction (D2) rotation of the crank shaft (58) is determined

[00053] During utilization of the vehicle (10) having the control system (300), when a request for the ignition of the engine (22) is registered, for example when a rider turns the ignition key, the control system (300) starts receiving values of pressure at the inlet manifold (302) from the MAP sensor (308). During such time, the ISG controller (324) causes the ISG to rotate the crank shaft (58). For example, when the piston (62) is at a BDC (Bottom Dead Centre) position, the ISG rotates the crank shaft (58), to move the piston from the BDC position to the TDC (Top Dead Centre) position. In another example, when the piston (62) is at any position other than the TDC, the ISG rotates the crank shaft (58), to move the piston (62) from the BDC position to the TDC (Top Dead Centre) position.

[00054] During such movement of the crank shaft (58), the crank shaft position sensor (328), measures the pulses generated for example, with passage of the pip from the vicinity of the pulse sensor. The control module (310) of the control system (300), receives the output from the MAP sensor (308) and the crank angle sensor (328) and determines that that the engine (22) is rotating in forward motion, when the value from the MAP sensor (308) at the first pip is smaller than the threshold voltage. Likewise, the control module (310) determines that that the engine (22) is rotating in reverse motion when the value from the MAP sensor (308) at the first pip is greater than the threshold

voltage. Further, when the control module (310) determines that the engine is rotating in reverse motion, the control module (310) restricts firing of the engine (22) by the ignition system (319). Otherwise, when the control module (310) determines that the engine (22) is rotating in forward motion, the control module (310) allows firing of the spark plug (318) by the ignition system (319).

[00055] In light of the foregoing the present invention provides a system that prevents firing of the ignition system (319), when the engine (22) is rotating in reverse motion. By preventing the firing of the ignition system (319), when the engine (22) is rotating in reverse motion, the present invention reduces wastage of fuel, while also ensuring that there is no undesired damage to the various components of the engine (22). Further, the present invention provides a system for determining direction of rotation of the engine (22) only based on pressure of the inlet manifold (302), and the position of the crankshaft (). Therefore, the present invention, in an embodiment thereof, assists in determining the direction of rotation of the engine (22), when an ISG controller (324) is used for initially rotating the crankshaft and the ISG controller is delinked from the ECU (310) controlling the ignition of the engine (22).

[00056] While few embodiments of the present invention have been described above, it is to be understood that the invention is not limited to the above embodiments and modifications may be appropriately made thereto within the spirit and scope of the invention.

[00057] While considerable emphasis has been placed herein on the particular features of this invention, it will be appreciated that various modifications can be made, and that many changes can be made in the preferred embodiments without departing from the principles of the invention. These and other modifications in the nature of the invention or the preferred embodiments will be apparent to those skilled in the art from the disclosure herein, whereby it is to be distinctly understood that the foregoing descriptive matter is to be interpreted merely as illustrative of the invention and not as a limitation.

We claim:

1. A vehicle (10) comprising:

an internal combustion engine (22) comprising:

a combustion chamber (64) defined by a cylinder head (56) and a crank
5 case (52);

a crankshaft (58) rotatably supported by the crank case (52); and

a spark plug (318) for firing of charge;

an intake manifold (302) and an exhaust manifold (304) fluidically coupled to
the combustion chamber (64);

10 a rotary electric machine (322) configured to rotate the crankshaft (58), at a
time of engine start;

a manifold absolute pressure (MAP) sensor (308) disposed in the intake
manifold (302), wherein the MAP sensor (308) is configured to detect
pressure in the intake manifold (302); and

15 a crank angle sensor (328) configured to detect angular position and rpm of the
crankshaft (58) of the internal combustion engine (22); and

a control system (300) configured to control the internal combustion engine (22),
wherein the control system (300) comprises:

20 an electronic control unit (ECU) (310) in electronic communication with the
MAP sensor (308) and the crank angle sensor (328), wherein the
electronic control unit (310) configured to:

receive output of the MAP sensor (308) and the crank angle sensor
(328); and

25 determine rotational direction of the crankshaft (58) based on the output
of the MAP sensor (308) and the crank angle sensor (328).

2. The vehicle (10) as claimed in claim 1, wherein the electronic control unit (ECU)
(310) is further configured to selectively allow and restrict firing of the spark

plug (318) in response to determination of the rotational direction of the crank shaft (58).

3. The vehicle (10) as claimed in claim 1, wherein the rotary electric machine (322) is mounted on the crankshaft (58) and comprises at least one reference tooth, wherein the at least one reference tooth is indicative of a predetermined position on the crank shaft (58) and a plurality of teeth (326) positioned angularly along circumference of the rotary electric machine (322), each teeth of the plurality of teeth (326) from the reference tooth indicates predetermined angular positions of the crank shaft (58).
4. The vehicle (10) as claimed in claim 3, wherein the reference tooth has a predetermined profile or is in form of absence of a tooth.
5. The vehicle (10) as claimed in claim 1, wherein the MAP sensor (308) generates a voltage signal in response to the sensed pressure in the intake manifold (302) and the crank angle sensor (328) generates a voltage signal indicative of the angular position of the crank shaft (58), wherein the voltage signal generated by the MAP sensor (308) and the crank angle sensor (328) are communicated to the electronic control unit (310).
6. The vehicle (10) as claimed in claim 1, wherein the crank angle sensor (328) generates a profile ignition pickup (PIP) signal indicative of the angular position of the crank shaft (58).
7. The vehicle (10) as claimed in claim 5, wherein the rotational direction of the crank shaft (58) is determined by the electronic control unit (310) based on the voltage signal of the MAP sensor (308) at a predetermined angular position of the crank shaft (58).

8. The vehicle (10) as claimed in claim 7, wherein the predetermined angular position of the crank shaft (58) is the first tooth of plurality of teeth (326) after the reference tooth.
- 5 9. The vehicle (10) as claimed in claim 7, wherein the crank shaft (58) is rotating in first rotational direction (D1) if the voltage generated by the MAP sensor (308) at the predetermined angular position of the crankshaft (58) is above a predetermined threshold value stored in the electronic control unit (310).
- 10 10. The vehicle (10) as claimed in claim 7, wherein the crank shaft (58) is rotating in second rotational direction (D2) if the voltage generated by the MAP sensor (308) at the predetermined angular position of the crankshaft (58) is below a predetermined threshold value stored in the electronic control unit (310).
- 15 11. The vehicle (10) as claimed in claim 7, claim 9 and claim 10, wherein the first rotational direction (D1) is reverse direction and the second rotational direction (D2) is forward direction.
- 20 12. The vehicle (10) as claimed in claim 1, wherein the rotary electric machine (322) is integrated starter generator (ISG).
13. The vehicle (10) as claimed in claim 1, wherein the crank angle sensor (328) is a pulsar coil.
- 25 14. The vehicle (10) as claimed in claim 1, wherein the crank angle sensor (328) is a Hall Effect sensor.
- 30 15. The vehicle (10) as claimed in claim 1, wherein the electronic control unit (ECU) (310) does not allow firing of the spark plug (318) till it determines the rotational direction of the crankshaft (58).

16. The vehicle (10) as claimed in claim 5, wherein the rotational direction of the crank shaft (58) is determined by the electronic control unit (310) based on first voltage signal of the MAP sensor (308) at a first predetermined angular position of the crank shaft (58) and a second voltage signal of the MAP sensor (308) at a second predetermined angular position of the crank shaft (58).
17. The vehicle (10) as claimed in claim 16, wherein the crank shaft (58) is rotating in first rotational direction (D1) if the first voltage generated by the MAP sensor (308) at the first predetermined angular position of the crankshaft (58) and the second voltage generated by the MAP sensor (308) at the second predetermined angular position of the crankshaft (58) is above a predetermined threshold value stored in the electronic control unit (310); and the crank shaft (58) is rotating in second rotational direction (D2) if the first voltage generated by the MAP sensor (308) at the first predetermined angular position of the crankshaft (58) and the second voltage generated by the MAP sensor (308) at the second predetermined angular position of the crankshaft (58) is below a predetermined threshold value stored in the electronic control unit (310).
18. A method (400) of controlling an internal combustion engine (22) by a control system (300), wherein the method (400) comprises:
- sensing air pressure in an intake manifold (302) via a manifold absolute pressure (MAP) sensor (308);
 - generating a MAP voltage signal (330) representative of the sensed air pressure;
 - sensing angular position of a crank shaft (58) of the internal combustion engine (22) via a crank angle sensor (328);
 - generating a voltage signal (332) representative of the angular position of the crank shaft (58); and

determining rotational direction of the crank shaft (58) by an electronic control unit (310), based on the generated MAP voltage signal (330) at a predetermined position of the crank shaft.

- 5 19. The method (400) as claimed in claim 18, wherein the electronic control unit (310) controls the sparking of the spark plug (318) based on the determined rotational direction of the crank shaft (58).
- 10 20. The method (400) as claimed in claim 18, wherein the crank shaft (58) is rotating in first rotational direction (D1) if the voltage generated by the MAP sensor (308) at the predetermined position of the crankshaft (58) is above a predetermined threshold value stored in the electronic control unit (310), wherein the electronic control unit (310) restricts the sparking of the spark plug (318), when first rotational direction (D1) rotation of the crank shaft (58) is
15 determined.
- 20 21. The method (400) as claimed in claim 18, wherein the crank shaft (58) is rotating in second rotational direction (D2) if the voltage generated by the MAP sensor (308) at the predetermined position of the crankshaft (58) is below a predetermined threshold value stored within the electronic control unit (310), wherein the electronic control unit (310) allows the sparking of the spark plug (318), when second rotational direction (D2) rotation of the crank shaft (58) is
20 determined.

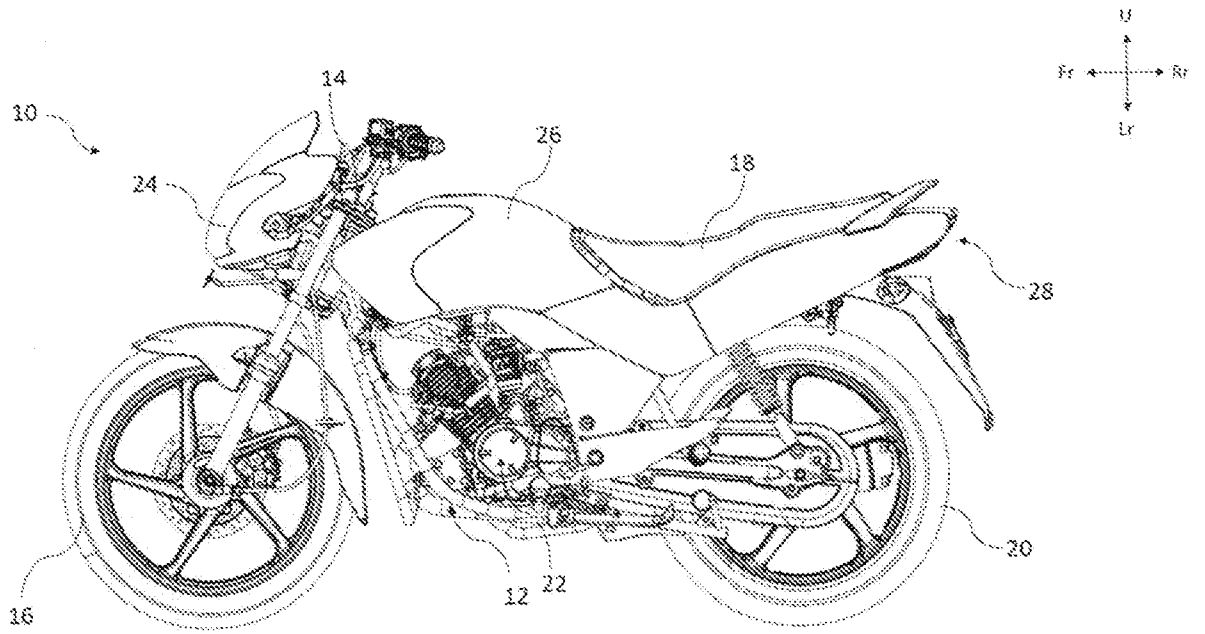

Figure 1

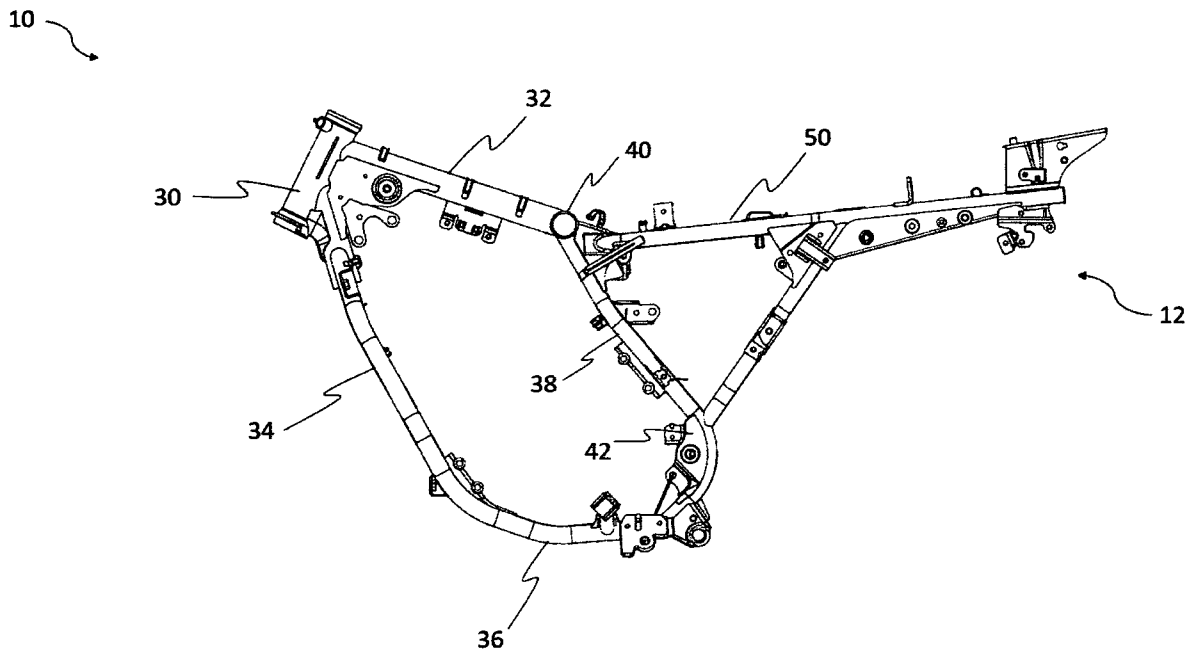
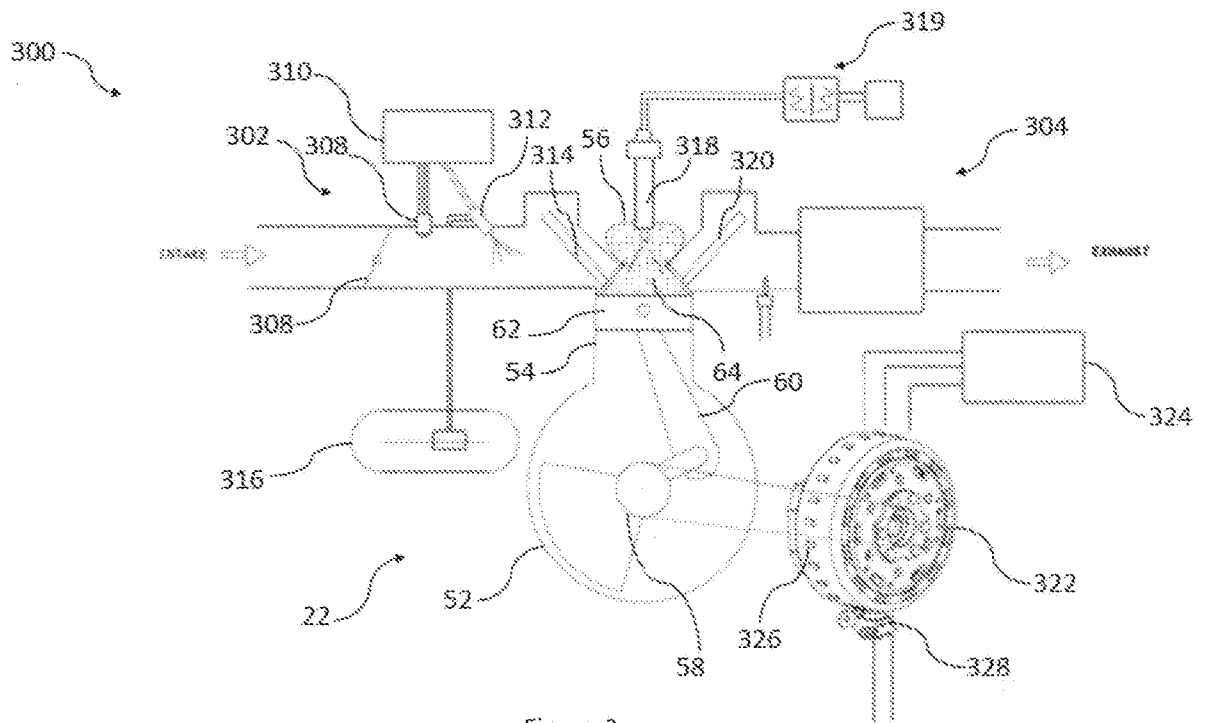

Figure 2



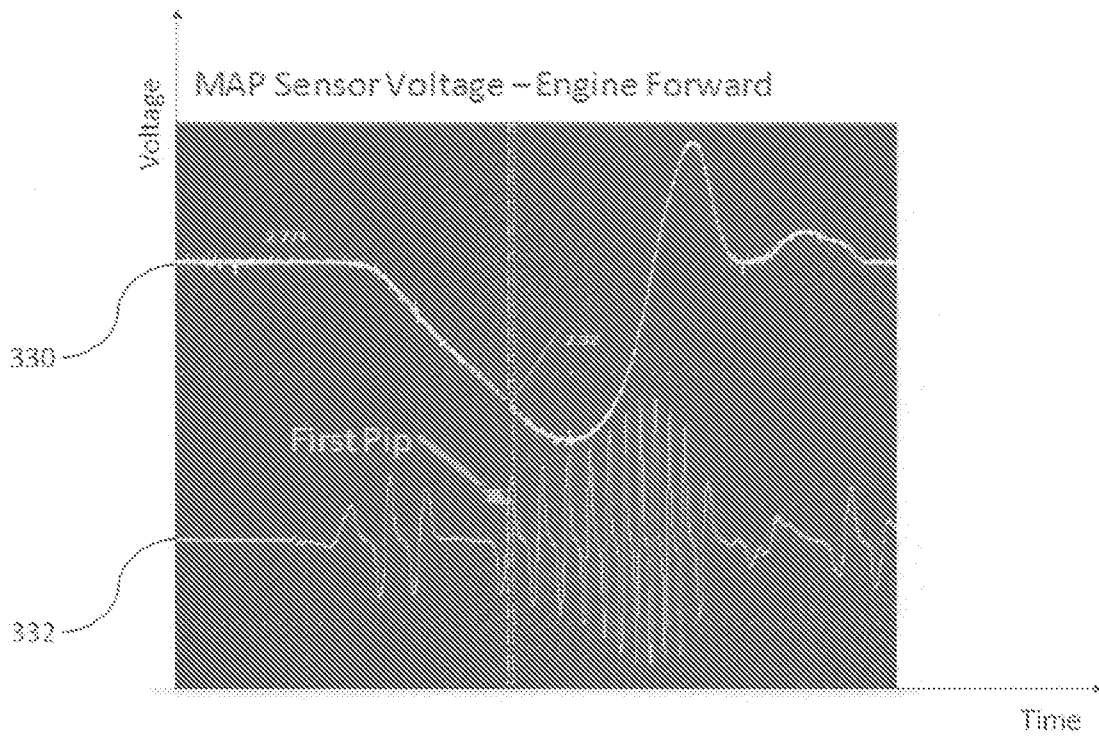

Figure 4

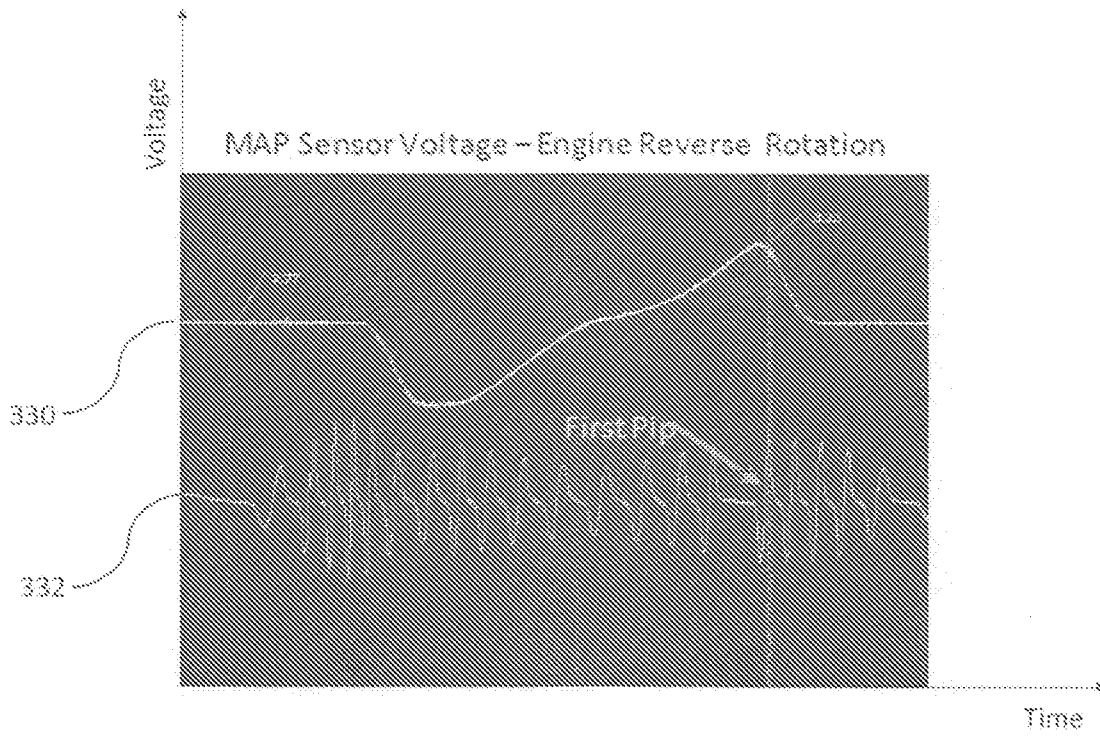

Figure 5

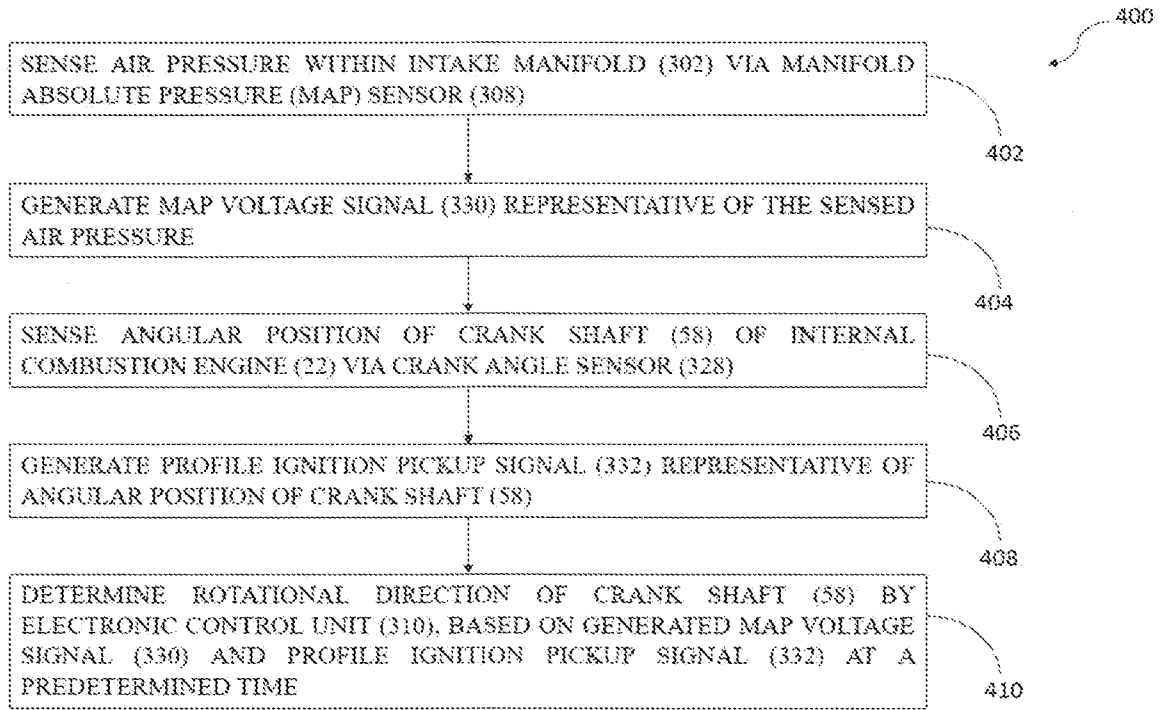

Figure 6

INTERNATIONAL SEARCH REPORT

International application No.
PCT/IN2020/050187

A. CLASSIFICATION OF SUBJECT MATTER F02D43/00,F02P5/15 Version=2020.01		
According to International Patent Classification (IPC) or to both national classification and IPC		
B. FIELDS SEARCHED		
Minimum documentation searched (classification system followed by classification symbols) F02D, F02P		
Documentation searched other than minimum documentation to the extent that such documents are included in the fields searched		
Electronic data base consulted during the international search (name of data base and, where practicable, search terms used) TotalPatent One, IPO Internal Database		
C. DOCUMENTS CONSIDERED TO BE RELEVANT		
Category*	Citation of document, with indication, where appropriate, of the relevant passages	Relevant to claim No.
X	US20030154777A1 (ORBITAL ENG PTY) 21 August 2003 (21.08.2003) description para [0050]-[0080], fig 1a, 1b	1- 5, 7-11, 15-21
X	US20150047607A1 (FORD GLOBAL TECH LLC) 19 February 2015 (19.02. 2015) description para [0018]-[0033], fig 1	1, 6, 12-14
A	US20130245914A1 (HITACHI AUTOMOTIVE SYSTEMS LTD) 19 September 2013 (19.09.2013) description para [0017]-[0068], fig 1	1-21
A	US20180320604A1 (FORD GLOBAL TECH LLC) 08 November 2018 (08.11.2018) description and fig 1	1-21
<input type="checkbox"/> Further documents are listed in the continuation of Box C. <input checked="" type="checkbox"/> See patent family annex.		
* Special categories of cited documents: "A" document defining the general state of the art which is not considered to be of particular relevance "D" document cited by the applicant in the international application "E" earlier application or patent but published on or after the international filing date "L" document which may throw doubts on priority claim(s) or which is cited to establish the publication date of another citation or other special reason (as specified) "O" document referring to an oral disclosure, use, exhibition or other means "P" document published prior to the international filing date but later than the priority date claimed "T" later document published after the international filing date or priority date and not in conflict with the application but cited to understand the principle or theory underlying the invention "X" document of particular relevance; the claimed invention cannot be considered novel or cannot be considered to involve an inventive step when the document is taken alone "Y" document of particular relevance; the claimed invention cannot be considered to involve an inventive step when the document is combined with one or more other such documents, such combination being obvious to a person skilled in the art "&" document member of the same patent family		
Date of the actual completion of the international search 09-07-2020		Date of mailing of the international search report 09-07-2020
Name and mailing address of the ISA/ Indian Patent Office Plot No.32, Sector 14,Dwarka,New Delhi-110075 Facsimile No.		Authorized officer Ajay Kumar Prajapati Telephone No. +91-1125300200

INTERNATIONAL SEARCH REPORT
Information on patent family members

International application No.
PCT/IN2020/050187

Citation	Pub.Date	Family	Pub.Date
US 20030154777 A1	11-08-2003	WO 2001083970 A1	08-11-2001
		EP 1280988 B1	15-11-2006
		CN 100489292 C	20-05-2009
		AT 345438 T	15-12-2006
		DE 60124528 T2	21-06-2007
		TW 575727 B	11-02-2004
		ES 2274880 T3	01-06-2007
US 20150047607 A1	19-02-2015	DE 102014216128 A1	19-02-2015
		CN 104369733 B	05-06-2018
		RU 2653665 C2	11-05-2018
US 20130245914 A1	19-09-2013	CN 103321770 B	20-10-2017
		DE 102013204198 A1	19-09-2013
		JP 5956794 B2	27-07-2016
US 20180320604 A1	08-11-2018	DE 102017207644 A1	08-11-2018
		CN 108798892 A	13-11-2018