

(12) INTERNATIONAL APPLICATION PUBLISHED UNDER THE PATENT COOPERATION TREATY (PCT)

(19) World Intellectual Property Organization
International Bureau



(43) International Publication Date
8 May 2003 (08.05.2003)

PCT

(10) International Publication Number
WO 03/037233 A1

(51) International Patent Classification⁷: A61F 7/00

(74) Agent: CHRISTOPHER, John; Christopher & Weisberg, P.A., Suite 2040, 200 East Las Olas Boulevard, Fort Lauderdale, FL 33301 (US).

(21) International Application Number: PCT/US02/34772

(22) International Filing Date: 30 October 2002 (30.10.2002)

(81) Designated States (national): CA, JP.

(25) Filing Language: English

(84) Designated States (regional): European patent (AT, BE, BG, CH, CY, CZ, DE, DK, EE, ES, FI, FR, GB, GR, IE, IT, LU, MC, NL, PT, SE, SK, TR).

(26) Publication Language: English

Published:

(30) Priority Data:
60/334,740 31 October 2001 (31.10.2001) US
10/274,757 21 October 2002 (21.10.2002) US

— with international search report
— before the expiration of the time limit for amending the claims and to be republished in the event of receipt of amendments

(71) Applicant and

(72) Inventor: LARNARD, Donald, J. [US/US]; 38 Depot Road, Hampton Falls, NH 03844 (US).

For two-letter codes and other abbreviations, refer to the "Guidance Notes on Codes and Abbreviations" appearing at the beginning of each regular issue of the PCT Gazette.

(54) Title: APPARATUS FOR THERMAL THERAPY

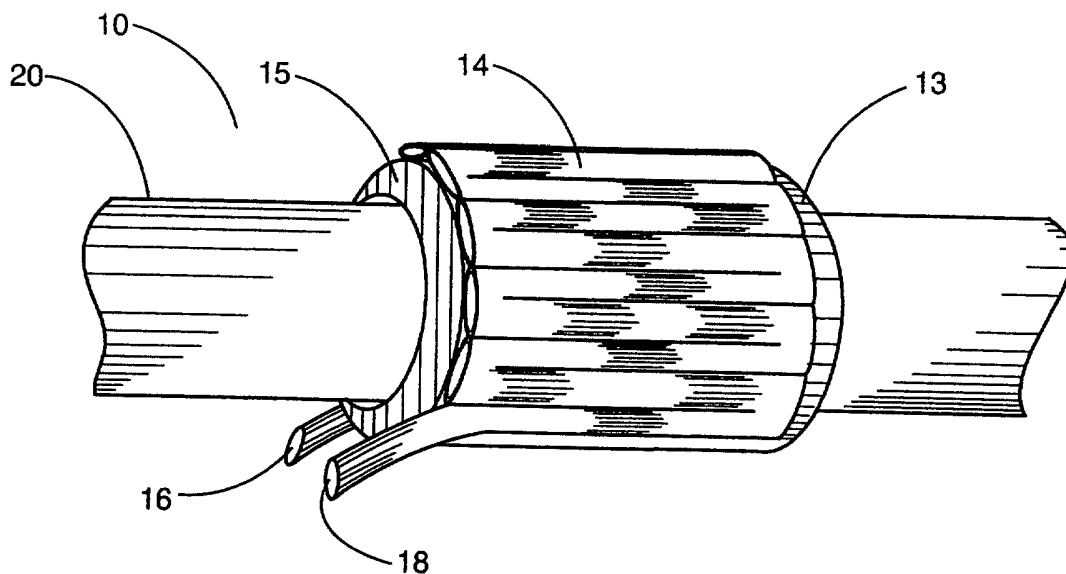

(57) Abstract: A medical device for controlling the temperature of a region of brain tissue, selective cooling of the brain is achieved by lowering the localized blood temperature of the internal blood vessel. The medical device controls the localized temperature of the brain by cradling the blood vessel and transferring thermal energy between the medical device and the blood vessel.



WO 03/037233 A1

APPARATUS FOR THERMAL THERAPY

FIELD OF THE INVENTION

The subject invention relates to a system and method for controlling the temperature of a region of brain tissue.

BACKGROUND OF THE INVENTION

Researchers and physicians have long recognized the consequences of reduction of body temperature in mammals, including induction of stupor, tissue damage, and death. Application of freezing and near freezing temperatures to selected tissue is commonly employed to preserve tissue and cell (e.g. sperm banks); and application of extreme cold (far below freezing) is effective for tissue ablation. However, localized cooling (not freezing) of tissue has generally been limited to the placement of an "ice-pack" or a "cold compress" on injured or inflamed tissue to reduce swelling and the pain associated therewith. Localized cooling of internal organs, such as the brain, has remained in large part unexplored.

For example, "brain cooling" has been induced by cooling the blood supply to the brain by inserting a chilled catheter into the arteries. However, as the effects of the cold blood cannot be easily localized, the shortcomings of systemically cooling the entire blood pool are realized, and the technique become impractical. Such shortcomings include cardiac arrhythmia, immune suppression and coagulopathies.

Attempts have been made to localize cooling of the brain with wholly external devices, such as cooling helmets or neck collars. Cooling helmets appear to be ineffective at reaching depths within the brain due to insufficient cooling power. Neck collars attempt to cool blood supplies and therefore become a systemic blood cooling method and thus are subject to the same shortcomings as other systemic cooling methods.

It is therefore desirable to obtain improved devices and methods that allow for localized brain cooling without the disadvantages of the known systemic and external devices and techniques.

SUMMARY OF THE INVENTION

The subject invention advantageously provides a system and method for controlling the temperature of a blood vessel. As described herein, the device lowers the localized blood temperature of the blood vessel by enveloping the blood vessel to transfer thermal energy

there between. In this manner the device can for example, can lower the localized blood temperature of the internal carotid artery to affect selective cooling of the brain.

The medical device of the subject invention controls the localized temperature of the blood vessel by surrounding the blood vessel and transferring thermal energy between the medical device and the blood vessel. The medical device includes a thermal support structure for surrounding the blood vessel, whereby the support structure is configured to control thermal energy transfer between the support structure and the blood vessel. In exemplary usage, the temperature is controlled using thermally-conductive fluid perfusion through the thermal structure surrounding an outside section of blood vessel.

In a method of use, the medical device is placed using a cut-down procedure, either sliding or placing the device under the dissected blood vessel and securing. In this way, one avoids any adjacent nerves, and assures that other peripheral or peri-vascular structures are insulated. Once secured, the thermally-conductive fluid enters the thermal transfer region, thereby effecting the localized blood temperature of the blood vessel. For example, the localized temperature of the blood vessel is lowered by a perfusion of thermally-conductive fluid having a temperature lower than that of the blood vessel. Alternatively, the localized temperature of the blood vessel is increased by a perfusion of thermally-conductive fluid having a temperature greater than that of the blood vessel.

BRIEF DESCRIPTION OF THE DRAWINGS

A more complete understanding of the subject invention, and the attendant advantages and features thereof, will be more readily understood by reference to the following detailed description when considered in conjunction with the accompanying drawings wherein:

FIG. 1 shows a perspective view of a flexible thermal support structure embodiment of the subject invention secured about the blood vessel;

FIG. 2 shows a perspective view of an alternative flexible thermal support structure embodiment of the subject invention secured about the blood vessel;

FIG. 3 shows a perspective view of a still further flexible thermal support structure embodiment of the subject invention secured about the blood vessel;

FIG. 4 shows a front view of a flexible thermal support structure of the subject invention;

FIG. 5 shows a perspective view of a substantially rigid two element embodiment of the subject invention;

FIG. 6 shows a perspective view of a substantially rigid three element embodiment of the subject invention;

FIG. 7 shows a perspective view of a substantially rigid four element embodiment of the subject invention;

FIG. 8 show a continuous bag thermal support structure embodiment of the subject invention;

FIG. 9 show an alternative continuous bag thermal support structure embodiment of the subject invention; and

FIG. 10 is a view of an exemplary system in a bundled state.

DETAILED DESCRIPTION OF THE INVENTION

The subject invention provides a device for controlling the temperature of a blood vessel. As described herein, the device lowers the localized blood temperature of the blood vessel by enveloping the blood vessel and transferring thermal energy there between. In this manner, the device can for example effect a selective cooling of the brain or other body organ or organ system.

Referring now to FIG. 1, the medical device includes a thermal support structure 12 for enveloping the blood vessel 20, whereby the thermal support structure 12 is configured to control thermal energy transfer between the thermal support structure 12 and the blood vessel 20. In exemplary usage, the temperature is controlled using thermally-conductive fluid perfusion through the thermal structure surrounding an outside section of the blood vessel. The thermally-conductive fluid lowers the localized blood temperature of the blood vessel, thereby effecting a selective temperature change.

In an embodiment, the thermal support structure 12 is a substantially flexible support structure 15, where the flexible support structure 15 is circumferentially wrapped about the blood vessel 20. The length of blood vessel circumferentially wrapped can be any length exposed by the cut down procedure and required by the flow of the vessel and the resting temperature of the blood to sufficiently cool the downstream tissue. The flexible support structure 15 can be made from, but not limited to, flexible materials including rubber, silastic or silicone.

As shown in FIG. 4, the flexible support structure 15 is secured about the blood vessel by, for example, the use of a hook and loop type fastener 30. Alternatively, the flexible support structure 15 can be fastened to itself by various other means including securing with a suture, piece of tape, or other securing method know in the art.

In an embodiment, a fluid conduit 14 is affixed to the exterior surface 13 of the flexible support structures 15. The fluid conduit 14 contains a fluid inlet 16 and fluid outlet 18 defining a fluid path through the fluid conduit 14. The fluid conduit 14 is orientated to create a thermal transfer region 19 on the flexible support structure 15, whereby the thermal transfer region 19 is in thermal communication with the blood vessel 20.

In an embodiment, the fluid conduit is flexible tubing, such as, but not limited to, silicone tubes, PET or Teflon tubing.

In an alternative embodiment, as show in FIG. 2, the fluid conduit 14 is affixed to the flexible support structure's 15 interior surface 11. As such, the flexible support structure 15 acts as thermal barrier protecting the adjacent nerves and tissues from thermal damage. In a further embodiment, as shown in FIG. 3, the fluid conduit 14 is integrated into the flexible support structure 15.

In an alternative embodiment the thermal support structure 12 is made up of substantially rigid side elements 22, where the side elements 22 are configured to at least partially surround the blood vessel 20. As shown in FIG. 5, in an exemplary embodiment, the thermal support structure 12 includes two side elements 22, where the side elements 22 are affixed in substantial perpendicular relation. The fluid conduit 14 is affixed to the side elements 22 and orientated to create a thermal transfer region 19, whereby the thermal transfer region 19 is in thermal communication with the blood vessel 20.

In an embodiment, a fluid conduit 14 is affixed to the interior surface 21 of the side elements 22. As such, the side elements 22 act as thermal barrier protecting the adjacent nerves and tissues from thermal damage. The fluid conduit 14 contains a fluid inlet 16 and fluid outlet 18 defining a fluid path through the fluid conduit 14. The fluid conduit 14 is orientated to create a thermal transfer region 19 on the side elements 22, whereby the thermal transfer region 19 is in thermal communication with the blood vessel 20.

In an alternative embodiment, not shown, the fluid conduit 14 is affixed to the exterior surface of the side elements 22.

In a further embodiment, not shown, the fluid conduit 14 is integrated into the side elements 22.

In an alternative embodiment, as shown in FIG. 6, the support structure 12 includes three side elements 22, where the side elements are affixed together forming an open channel, having a pair of substantially parallel vertical elements 22 and a horizontal element 24. The fluid conduit 14 is affixed to the vertical elements 22 and a horizontal element 24, orientated

to create a thermal transfer region 19, whereby the thermal transfer region 19 is in thermal communication with the blood vessel 20.

In an embodiment as shown in FIG. 7, the support structure further includes a cover 28, whereby the cover is hingeably connected to a first vertical side element 26. The cover 28 is rotated over the blood vessel 20 contacting the opposing vertical side element 26. The thermal support structure 12 can be secured about the blood vessel 20 by various means, including, but not limited to, securing with the use of a hook and loop type fastener, a suture, a piece of tape, or other securing methods known in the art.

The side elements 22 can be made from an insulating material, such as, plastic or rubber, where the insulating material insulates the adjacent tissue and nerves from thermal damage.

In an alternative embodiment, as shown in FIG. 8, the thermal support element 12 can be a continuous bag 32 or polymer sac, where portions of the bag 32 are selectively sealed 34 to define a fluid path therethrough. The fluid path is oriented such that the bag 32 contains a fluid inlet 36 and fluid outlet 36 and to create a thermal transfer region 40, whereby the thermal transfer region 40 is in thermal communication with the blood vessel 20.

In alternative embodiment, as shown in FIG. 9, the continuous bag 32 includes a fluid conduit 14 positioned within the bag 32. The fluid conduit 14 contains a fluid inlet 16 and fluid outlet 18 defining a fluid path through the fluid conduit 14. The fluid conduit 14 is orientated to create a thermal transfer region 19 in the continuous bag 32, whereby the thermal transfer region 19 is in thermal communication with the blood vessel 20.

The continuous bag 32 can be secured about the blood vessel 20 by various means, including, but not limited to, securing with the use of a hook and loop type fastener, a suture, a piece of tape, or other securing methods known in the art.

In an exemplary system, as shown in FIG. 10, the fluid inlet 16 is in fluid communication with a thermally-conductive fluid source 94 and the fluid outlet 18 is in fluid communication with the thermally-conductive fluid source 94 such that a fluid circulation circuit is defined. In practice, once the thermal support structure 12 is positioned and secured about the blood vessel 20, the thermal transfer region 19 being in thermal communication with the blood vessel 20, the thermally-conductive fluid enters the thermal transfer region 19, through the fluid inlet 16, thermally affecting the blood vessel 20. Simultaneously, the fluid outlet 18 excavates the thermally-conductive fluid from the thermal transfer region 19. In this manner, the thermal transfer region 19 affects a specific controlled temperature to the blood vessel 20.

The thermally-conductive fluid can be water, saline, a mixed fluorocarbon solution, or a refrigerant which is cooled by a thermoelectric cooler or a refrigerant fluid. The mixed fluorocarbon solution may be compounded such that it is deployed in liquid form wherein the liquid undergoes a phase change and transforms to a gas at a tailored boiling point.

In an embodiment, not shown, the thermally-conductive fluid source 94 can be responsive to input from a user input device 56 to permit flow of the thermo-conductive fluid into the thermo transfer region 19. One or more temperature sensors in electrical communication with the thermally-conductive fluid source 94 can be provided to regulate or terminate the flow of thermo-conductive fluid into the thermal transfer region 19 when a predetermined temperature at a selected point or points on or within the thermal transfer region 19 is/are obtained.

In an exemplary method of use, the medical device is placed using a cut-down procedure, either sliding or placing the device under the dissected blood vessel and securing. In this way, any adjacent nerves or vascular structures are insulated to avoid thermal damage. Once secured, the thermally-conductive fluid enters the thermal transfer region 19, through the fluid inlet 16, thermally affecting the blood vessel 20, thereby affecting the localized blood temperature of the blood vessel to effect selective temperature change. The selective temperature range achieved in the blood can be any temperature between zero degrees Celsius and normal blood temperature of 37 degrees Celsius. The temperature of the circulating fluid entering the thermal transfer region can be any temperature needed to reach the selective temperature range in the blood.

In an embodiment, of a method of use, the temperature of thermally-conductive fluid entering the thermal transfer region is less the temperature of the blood vessel. As such, the thermally-conductive fluid has a cooling effect on the blood vessel, thereby lowering the localized blood temperature of the blood vessel to effect selective cooling.

In additional embodiment, of a method of use, the temperature of the thermally-conductive fluid entering the thermal transfer region is greater then the temperature of the blood vessel. As such, the thermally-conductive fluid has a warming effect on the blood vessel, thereby increasing the localized blood temperature of the blood vessel to effect selective warming.

In an exemplary method of use, the medical device is placed using a cut-down procedure, either sliding or placing the device under the dissected internal carotid artery and securing. In this way, one could avoid any peripheral or cranial nerves, assure that other peripheral or peri-vascular structures are insulated and avoid the carotid bulb area at the

bifurcation. Once secured, the thermally-conductive fluid enters the thermal transfer region 19, through the fluid inlet 16, thermally affecting the carotid artery.

For example, the temperature of the thermally-conductive fluid is lower than the temperature of the carotid artery, thereby lowering the localized blood temperature of the internal carotid artery to effect selective cooling of the brain.

It will be appreciated by persons skilled in the art that the subject invention is not limited to what has been particularly shown and described herein above. In addition, unless mention was made above to the contrary, it should be noted that all of the accompanying drawings are not to scale. A variety of modifications and variations are possible in light of the above teachings without departing from the scope and spirit of the invention, which is limited only by the following claims.

What is claimed is:

1. A medical device comprising a thermal transfer structure adapted to envelop at least a portion of a blood vessel.
2. The medical device according to claim 1, wherein the thermal transfer structure is configured to control thermal energy transfer between the thermal transfer structure and the blood vessel.
3. The medical device according to claim 1, further comprising a thermally-conductive fluid in fluid communication with the thermal transfer structure.
4. The medical device according to claim 1, where the thermal transfer structure substantially surrounds a predetermined length of the blood vessel.
5. The medical device according to claim 1, wherein the thermal transfer structure comprises:
a thermal support structure; and
a thermal transfer region including a fluid inlet and a fluid outlet defining a fluid path through the thermal transfer region,
wherein the thermal transfer region is affixed to the thermal support structure.
6. The medical device according to claim 5, wherein the thermal transfer region is affixed to an interior surface of the thermal support structure.
7. The medical device according to claim 5, wherein the thermal transfer region is affixed to an exterior surface of the thermal support structure.
8. The medical device according to claim 5, wherein the thermal transfer region is integrated into the thermal support structure.

9. The medical device according to claim 5, wherein the thermal support structure comprises a plurality of substantially rigid side elements.
10. The medical device according to claim 5, wherein the thermal support structure comprises at least two substantially rigid side elements.
11. The medical device according to claim 5, wherein the thermal support structure comprises at least three substantially rigid side elements.
12. The medical device according to claim 11, wherein the thermal support structure further comprises a cover element.
13. The medical device according to claim 5, wherein the thermal support structure is a flexible membrane, wherein the flexible membrane at least partially envelops the blood vessel.
14. The medical device according to claim 5, wherein the thermal support structure is a continuous bag, wherein the continuous bag at least partially envelops the blood vessel.
15. The medical device according to claim 14, wherein the thermal transfer region is integrated into the continuous bag.
16. The medical device according to claim 5, wherein the thermal support structure includes a means for securing the thermal support structure about the blood vessel.
17. A medical device for affecting a localized temperature of a blood vessel comprising:
a thermal support structure; and
a fluid conduit containing a fluid inlet and a fluid outlet defining a fluid path through the fluid conduit, the fluid conduit being shaped forming a fluid transfer region,
wherein the fluid conduit is affixed to the thermal support structure.

18. A medical device for controlling the temperature of a blood vessel comprising:
 - a thermal support structure configured to surround at least a portion of the blood vessel;
 - a thermal transfer region attached to the thermal support structure, wherein the thermal transfer region is in thermal relation with the blood vessel; anda supply of thermally-conductive fluid in fluid communication with the thermal transfer region.

FIG 1

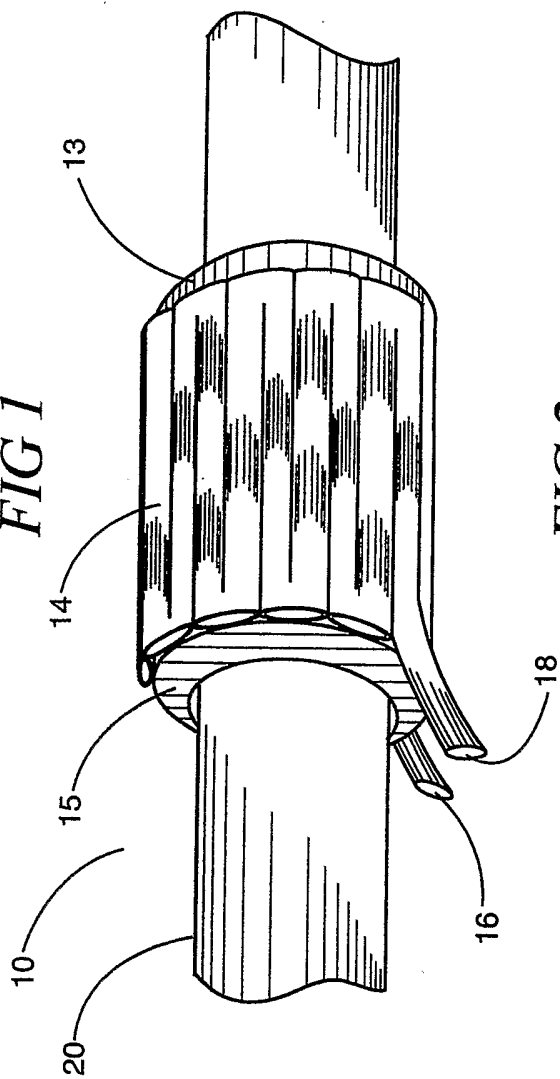

FIG 2

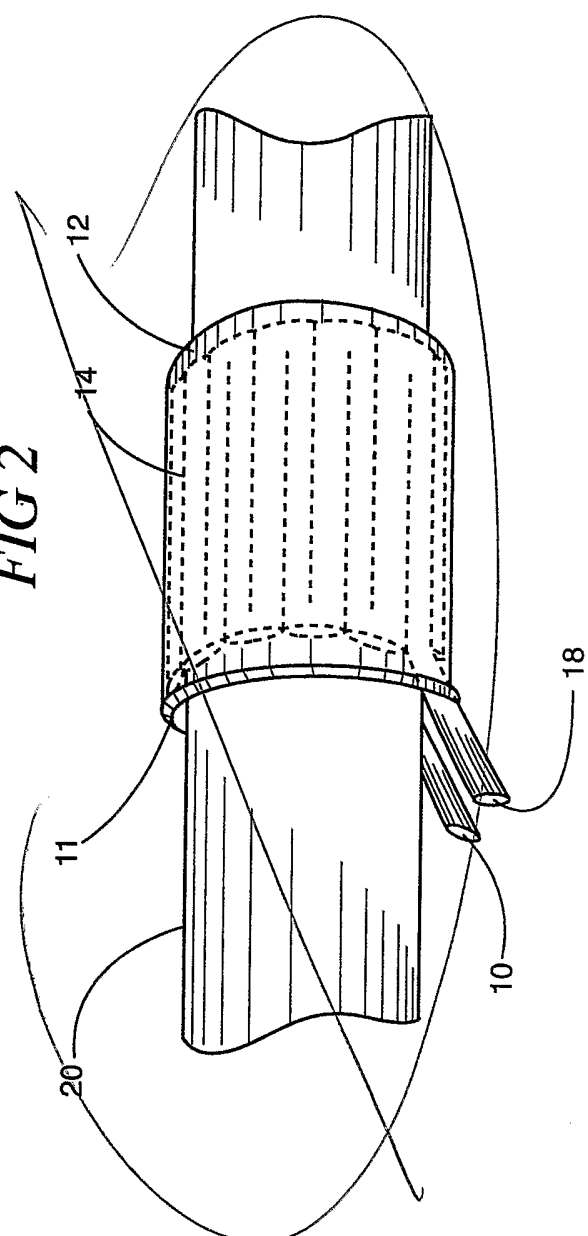

FIG 3

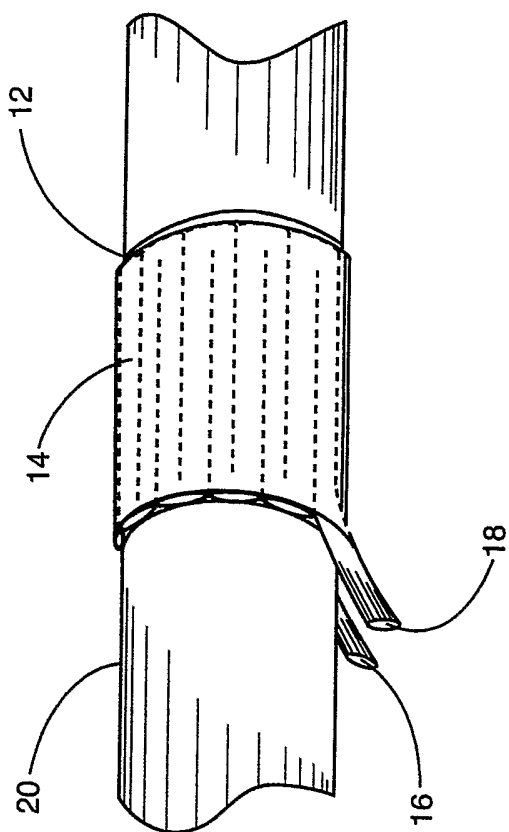

FIG 4

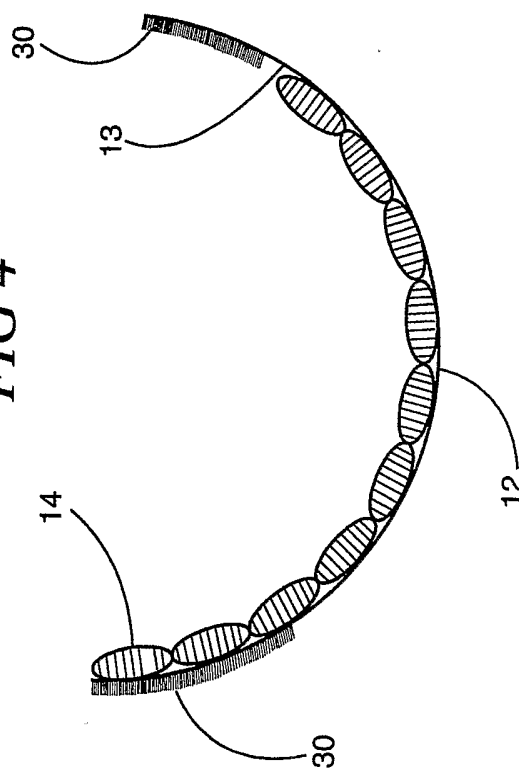

FIG. 5

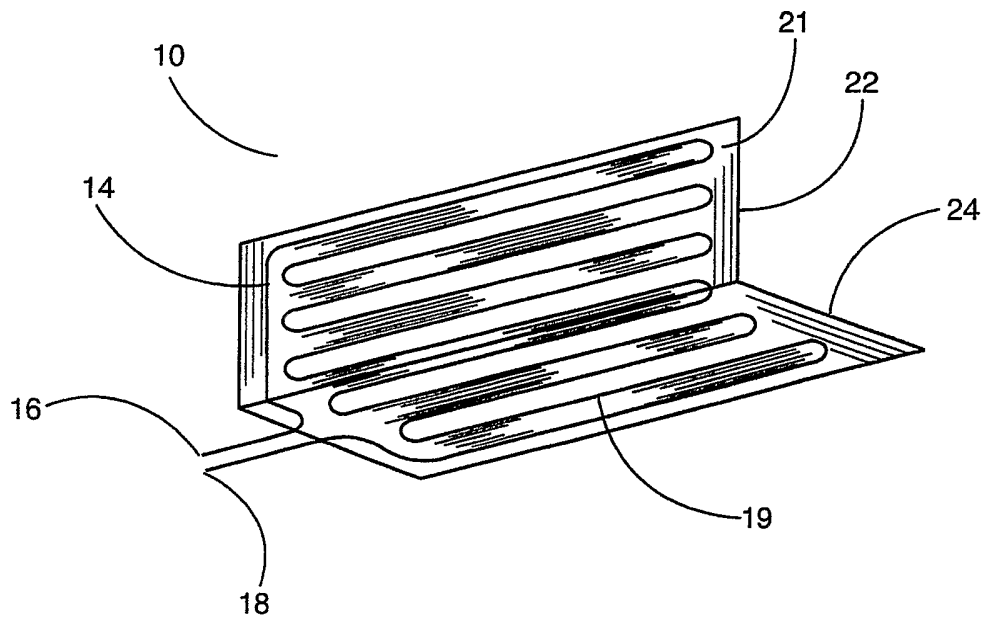

FIG. 6

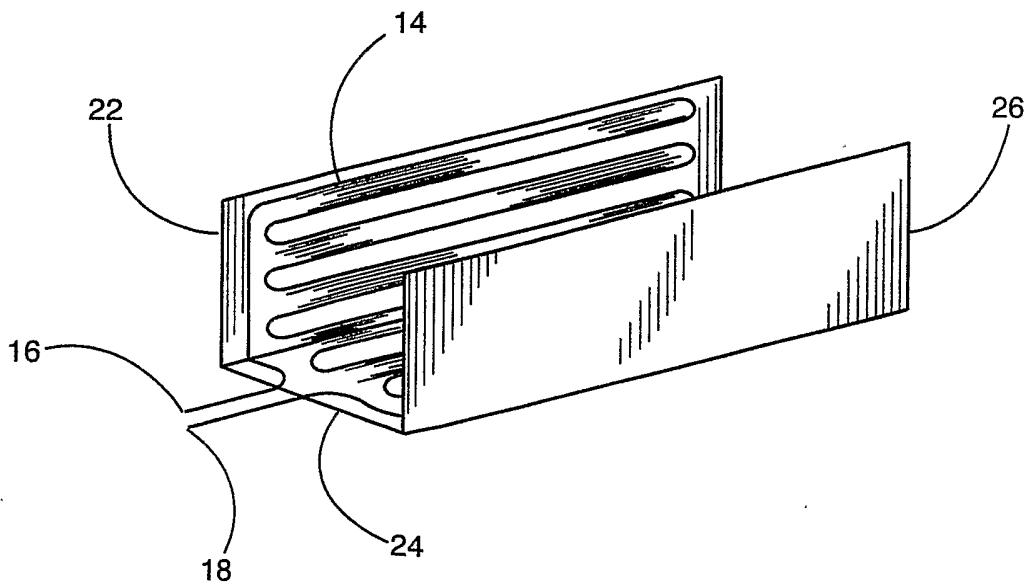

FIG. 7

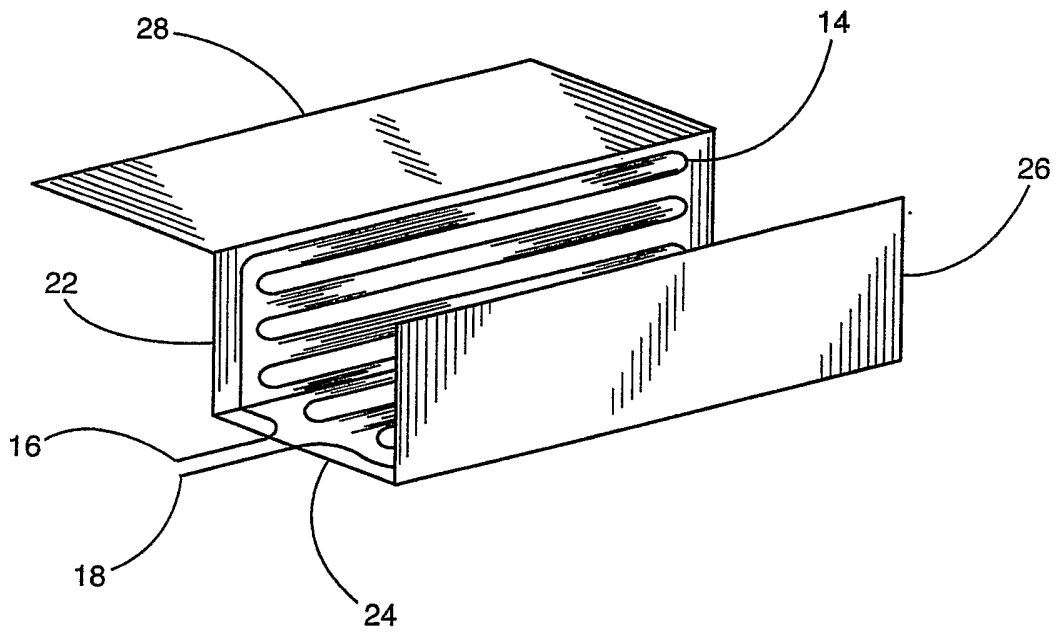

FIG. 8

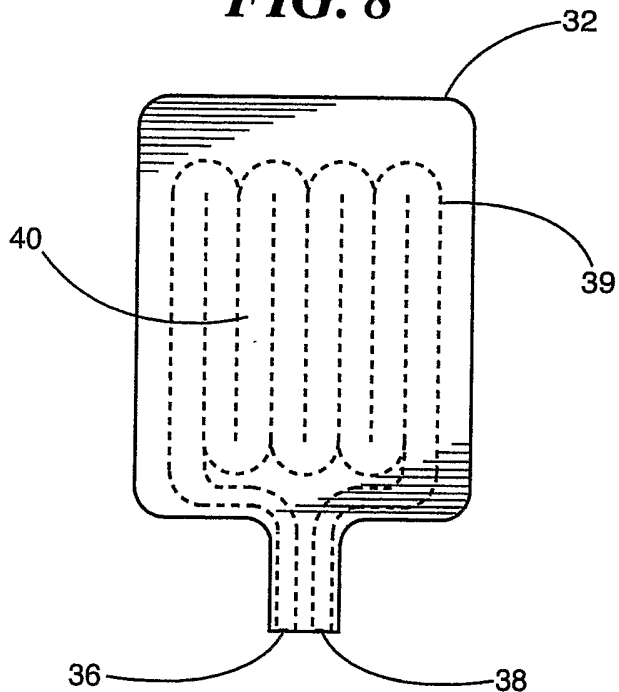

FIG. 9

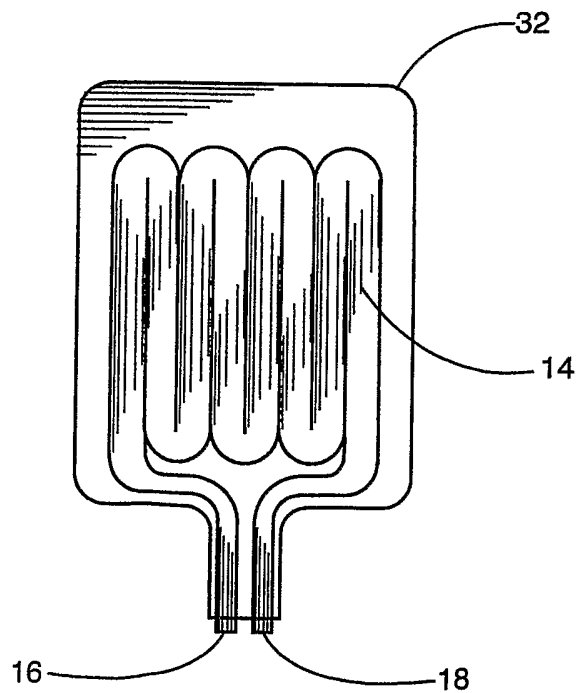
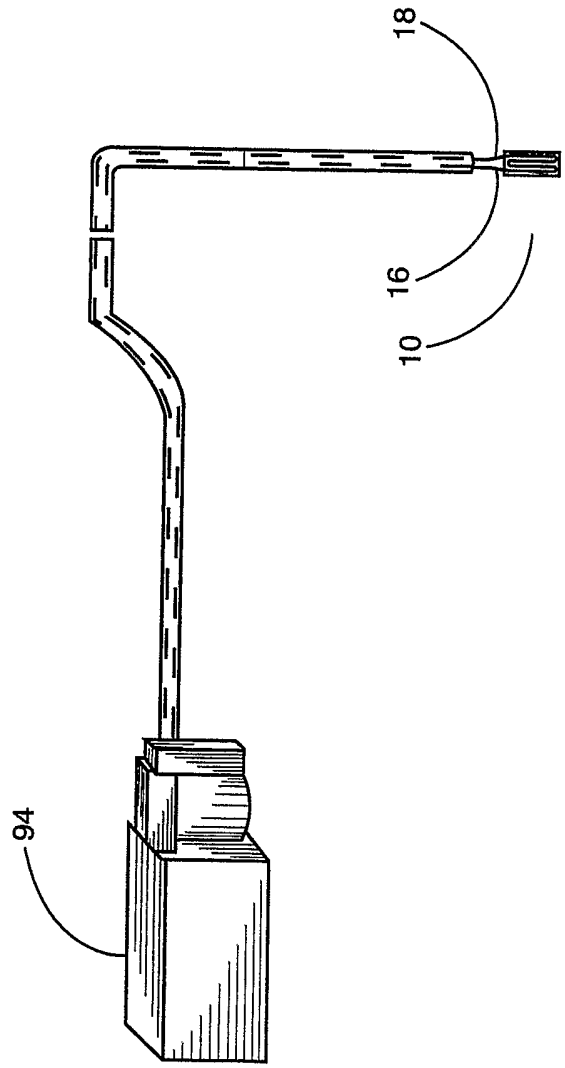

FIG 10



INTERNATIONAL SEARCH REPORT

International application No.

PCT/US02/34772

A. CLASSIFICATION OF SUBJECT MATTER		
IPC(7) : A61F 7/00		
US CL : 607/104-106		
According to International Patent Classification (IPC) or to both national classification and IPC		
B. FIELDS SEARCHED		
Minimum documentation searched (classification system followed by classification symbols) U.S. : 607/104-106		
Documentation searched other than minimum documentation to the extent that such documents are included in the fields searched NONE		
Electronic data base consulted during the international search (name of data base and, where practicable, search terms used) NONE		
C. DOCUMENTS CONSIDERED TO BE RELEVANT		
Category *	Citation of document, with indication, where appropriate, of the relevant passages	Relevant to claim No.
X	US 6,132,419 A (HOFFMANN) 17 October 2000, see entire document	1, 2, 4
<input type="checkbox"/> Further documents are listed in the continuation of Box C. <input type="checkbox"/> See patent family annex.		
* Special categories of cited documents:		
"A"	document defining the general state of the art which is not considered to be of particular relevance	"T" later document published after the international filing date or priority date and not in conflict with the application but cited to understand the principle or theory underlying the invention
"E"	earlier application or patent published on or after the international filing date	"X" document of particular relevance; the claimed invention cannot be considered novel or cannot be considered to involve an inventive step when the document is taken alone
"L"	document which may throw doubts on priority claim(s) or which is cited to establish the publication date of another citation or other special reason (as specified)	"Y" document of particular relevance; the claimed invention cannot be considered to involve an inventive step when the document is combined with one or more other such documents, such combination being obvious to a person skilled in the art
"O"	document referring to an oral disclosure, use, exhibition or other means	"&" document member of the same patent family
"P"	document published prior to the international filing date but later than the priority date claimed	
Date of the actual completion of the international search	Date of mailing of the international search report	
27 December 2002 (27.12.2002)	21 MAR 2003	
Name and mailing address of the ISA/US Commissioner of Patents and Trademarks Box PCT Washington, D.C. 20231 Facsimile No. (703)305-3230	Authorized officer Roy Gibson Telephone No. 703-308-3520	