

W. L. Williams,

Bundling Wood.

No 25,156.

Patented Aug. 16, 1859.

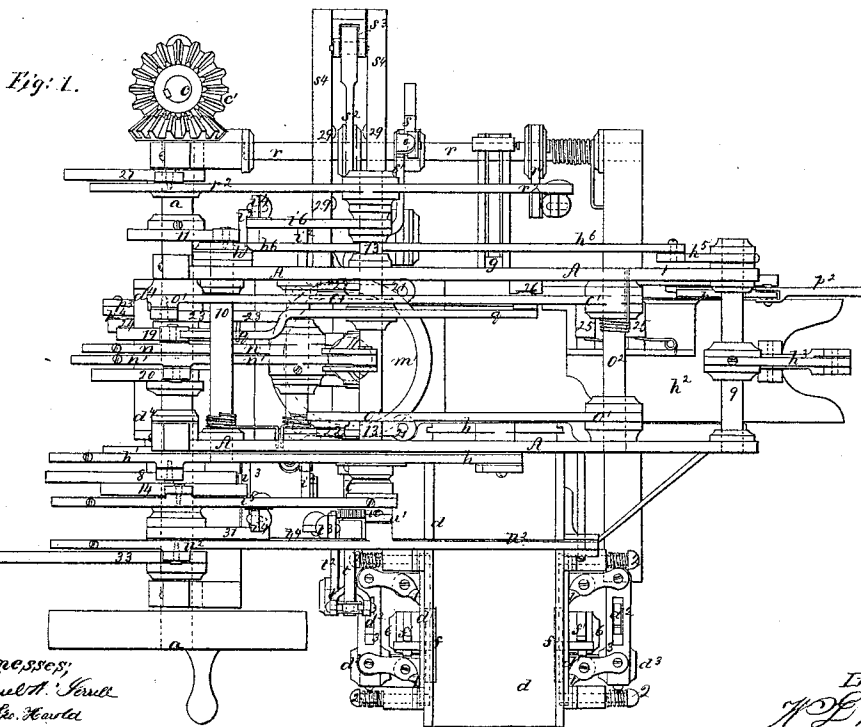
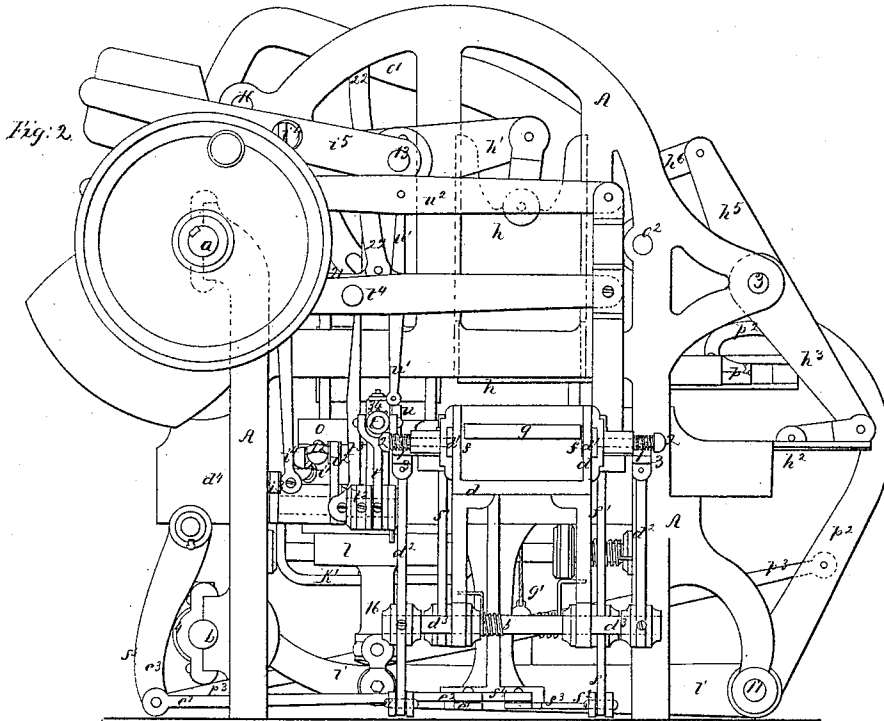

Witnesses;  
Samuel H. Sewell  
Chas. E. Howard

Inventor;  
W. L. Williams

W. L. Williams,

Bundling Wood.

N<sup>o</sup> 25,156.

Patented Aug. 16, 1859.

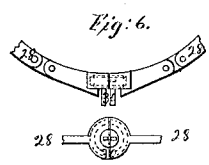
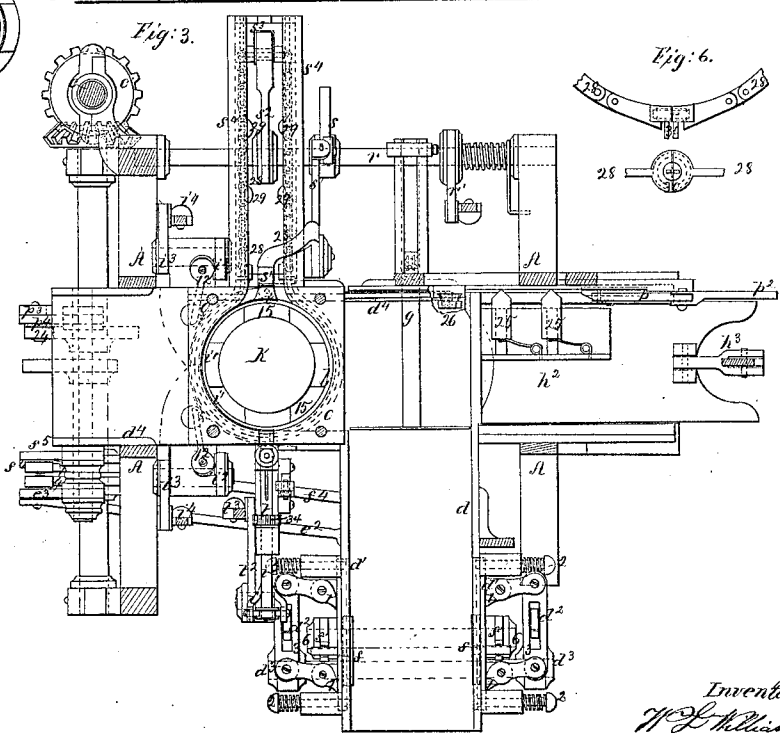
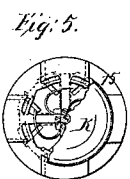
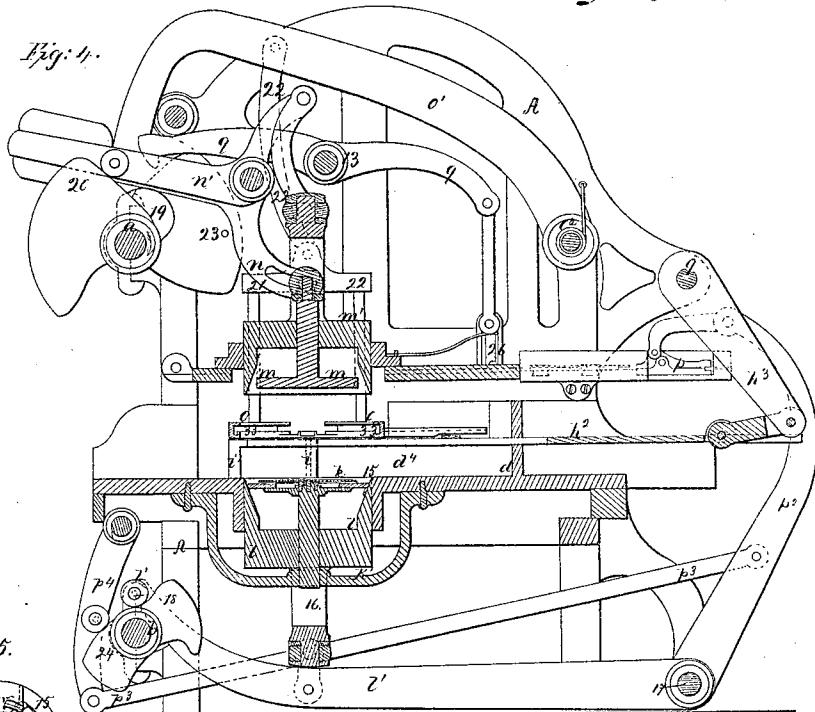

Witnesses:  
 Samuel W. Kauld.  
 And Geo. Kauld.

Inventor:  
 W. L. Williams

# UNITED STATES PATENT OFFICE.

WILLIAM L. WILLIAMS, OF NEW YORK, N. Y.

## MACHINE FOR BUNDLING KINDLING-WOOD.

Specification of Letters Patent No. 25,156, dated August 16, 1859.

To all whom it may concern:

Be it known that I, WILLIAM L. WILLIAMS, of the city, county, and State of New York, have invented and made certain new and useful Improvements in Machinery for Bundling Kindling-Wood; and I do hereby declare that the following is a full, clear, and exact description of the construction and operation of the same, reference being had to the annexed drawing, making part of this specification, wherein—

Figure 1, is a general plan of said machine. Fig. 2 is a side elevation. Fig. 3 is a plan at the bed on which the kindling wood moves, and Fig. 4 is a vertical transverse section.

Similar marks of reference denote the same parts.

My said invention consists in a machine that takes fire wood, as split up by a competent machine, and bundles the same, by passing a wire or its equivalent around it, so as to secure the said kindling wood in such bundles of a size convenient for sale or for handling. To accomplish this purpose I feed the wood along in a trough, separate from the mass the amount necessary for a bundle, the pieces standing end upward; I then convey away said wood to a compressing apparatus to consolidate the mass, and while thus held pass a wire around the same and twist the ends together, the complete bundle is then forced out and the operation is completed.

In the drawing *a*, is the main shaft or prime mover, *b*, is a secondary shaft connected to *a*, by the miter gearing *c'* and vertical shaft *c*, so that both move with uniformity and from these shafts *a* or *b* all the other parts receive their motion.

*d* is a feeding trough into which the wood is passed from the splitting machine, and is fed along by clamps *f*, that are projected onto the wood and slid along as next set forth.

*d'* are slides that are projected inward by cams 1, 1, and 2, 2 are studs that guide the said slides, and have springs to throw them back. The cams 1, 1, are connected by links 3, 3, and are actuated by arms *d''* on a cross shaft *d'''*, provided with a coiled spring 5, to throw the parts back to their former position; and in the links 3, 3, blocks of rubber are provided to yield and prevent any injury to the parts.

*e*, is a link from *d''* to a right angle crank

*e'* from which a link *e''* passes to the pendent lever *e'''*, against which the cam 4, properly shaped and timed, acts. In the slides *d'* the feeding clamps *f* are fitted to slide and carry the wood along.

*f'* are levers on a cross shaft 6, and *f''* is link to the right angle crank or bent lever *f'''*, from which a link *f''''* passes to the pendent lever *f'''''*, acted on by the cam 7. The parts are so timed that the slides *d'* press the blocks *f* against the wood, said blocks *f* then are slid along feeding the wood, the slides then draw back, and the blocks *f* return to their former position.

*g* is a sliding support to keep the wood from falling over as it goes forward.

*g'* is a weight and cord keeping the support *g* up to the wood but allowing the same to yield as the wood is pressed against *g*.

*h*, is a knife that is thrown down by the lever *h'* and cam 8, (on *a*,) that divides and separates the wood for each bundle when the proper amount has been forced into the trough *d''*, as aforesaid, and *h''*, is a sliding concave ended carrier that moves the wood along in the trough *d''*, and one bundle of wood secured by a wire as hereafter set forth is pressed out as the carrier *h''*, moves the wood along and the gatherers *i'*, *i''*, close onto the wood, and these gatherers *i'*, *i''*, and the semicircular end of *h''* form the wood into a loose circular bundle. The carrier *h''* is slid along by the lever *h'''* on the cross shaft 9, from which the lever *h''''*, and link *h'''''*, pass to the arm *h''''''*, said arm *h''''''* being on a shaft 10, provided with a spring to keep the arm *h''''''*, to the cam 11 on shaft *a*.

The curved gatherers *i'* are hinged to *d''* at *i*, and are opened and closed at the proper times by links 12, to cranks *i''*, and *i'''*, the latter of which are linked by *i''''*, *i'''''* to levers *i''''''* and *i'''''''* on a cross shaft 13, and the lever *i''''''''* is weighted and moved by the cam 14 on *a*.

The next operation is to compress the wood into a compact bundle, for this purpose I have two hollow conical plungers that press over the edges of the bundle and force the same together while a plunger from above brings the ends of the wood level.

*l*, is the lower conical gatherer, that rises up through a circular opening in the bottom of trough *d''*. This is raised by a lever *l'* and sling 16.

17 is a shaft forming the fulcrum for *l'*, and 18 is a cam on *b*, to elevate this conical

gatherer. In order to support the wood at the level of the bottom of trough  $d^4$  I provide a disk  $l$ , on a vertical spindle sustained by the cross bridge  $k'$ , said disk being with-  
 5 in this gatherer and stationary at the level of the bottom of  $d^4$ , and beneath this disk segmental plates, sliding one above the other as seen in Fig. 4 and in the plan Fig. 5, are provided, said segments being kept  
 10 out by springs, and being forced in by the conical inner surface of  $l$ , as it rises around the wood standing on this disk and segmental plates.

$m'$  is a conical gatherer similar to  $l$ , that is simultaneously pressed onto the wood by means of a lever  $n'$  and sling; the lever  $n'$ , being acted on by the cam 20 on  $a$ . Through this conical gatherer  $m'$  a bar passes, having on its end a plunger or press block  $m$ , that  
 20 is forced down by the lever  $n$ , and its cam 19 to bring the upper ends of the wood level, and also to hold said wood while the conical gatherer  $m'$  commences to lift so that the wood does not remain wedged into this conical gatherer. The cams are so shaped and  
 25 positioned that the conical gatherers separate after the wire has been passed around the bundle as next set forth and the bundle is ready for delivery.

I provide a hollow square frame  $o$ , with a circular opening and give to said frame a vertical movement. When elevated the frame is out of the way of the bundle being delivered and the next supply of wood in-  
 30 troduced, when depressed, the frame surrounds the wood, which occupies its circular opening, and a traveler conveys the wire around the bundle, which wire had been introduced into the frame when elevated.  
 35 This frame  $o$ , is provided with four rods passing through the plate that guides the gatherer  $m'$ , said rods are connected at their upper ends by cross heads 21, from which links 22, pass to the levers  $o'$ , on the  
 40 cross shaft  $o^2$ , and 23 is a cam acting on  $o'$  to elevate or depress the frame  $o$ .

$p$  is a traveling clamp moved by a lever  $p^2$  on shaft 17,  $p^3$  is a link to  $p^4$ , a pendent lever acted on by the cam 24, on shaft  $b$ .  
 45 The wire passes through this traveling clamp  $p$ , and is by it projected forward each movement beneath the cutter 26 into the frame  $o$ , when in its elevated position. The cutter 26 is moved by the lever  $q$ , and a pin on the side of the cam 23, and a clamping edge on the cutter holds onto the end of the wire while the traveling clamp moves back. The length of wire as cut off occupies the groove 33, and is projected through the hollow  
 50 frame  $o$ . I cause this frame to descend as before stated and carry the wire around as next described.

$r$ , is a shaft receiving an oscillating motion from the crank  $r'$  and link to  $r^2$ , a lever  
 5 acted on by cam 27.  $s$  is a cam on this shaft

$r$ , acting on a lever  $s'$ , that clamps the wire at its center as it lies in the frame  $o$ .

$s^2$  is a slotted crank arm acting on a traveler  $s^3$ , that moves in slides  $s^4$  and projects forward a flat linked chain traveling in a  
 70 circular groove around the inside of frame  $o$ , and at the end of the chain on each side there is a jaw 30, that conveys the wire around the bundle of wood, and 29 are blocks on the chain which force the wire  
 75 against the wood. The construction of these jaws is shown in larger size in Fig. 6, wherein it will be seen that when the jaws come together a cylindrical nut is formed which can be revolved within the end pieces  
 80 of the chain to twist the ends of the wires retained between said jaws, and that neither jaw can become detached from its place because a dovetail ring is formed around the edges, hence when revolved the respective  
 85 jaws pass out of one end part of the chain into the next. The means which I employ to revolve these jaws consist of the shaft  $t$ , that is formed as a square opening taking projecting pieces from the jaws 30. This  
 90 shaft  $t$  is fitted to slide endwise in its bearings and is kept in position by a spring key and slot in one side, which slot or groove guides the shaft, but the key therein springs  
 95 out by an inclination when the shaft is revolved. End motion is given to this shaft  $t$ , at the right time by an arm  $t'$ , crank  $t^2$ , link  $t^3$ , and lever  $t^4$  acted on by a cam 31.

$u$  is a rack with a link  $u'$ , to the lever  $u^2$ , and its cam 32, and 34, is a pinion on the  
 100 shaft  $t$ .

The operation of this part is that when the jaws 30, have carried the wire around the bundle of wood and come together the shaft  $t$ , is slid endwise throwing pinion 34,  
 105 into gear with the rack  $u$ , the rack is raised which rotates both the shaft  $t$  and the jaws 30 twisting the wire, that completes the bundling operation. The parts then all return to their former position and the operation is repeated. In all instances the movements of the parts are given primarily by  
 110 cams or their equivalents, and the springs or weighted levers effect the return motion. As the wire is projected into the machine  
 115 by the traveling clamp  $p$ , it might bend on account of being annealed and soft. I therefore provide the sliding spring guides 25, that keep the wire in position and are themselves forced out of the way by the clamp  $p$ ,  
 120 as it moves along.

What I claim as my invention and desire to secure by Letters Patent, is—

1. The feeding clamps  $f$  and slides  $d'$ , arranged and actuated in substantially the  
 125 manner and for the purposes set forth.

2. I claim the combination of the separating and dividing knife  $h$ , with the concave wood carrier  $h^2$ , to convey the wood to the bundling apparatus, as specified.  
 130

3. I claim the sliding support  $g'$ , arranged and acting as set forth to sustain the kindling wood as fed into the machine and keep it in place as described and shown.

5 4. I claim the curved gatherers  $i'$ , fitted and acting as set forth to deliver the bundle of wood and gather the next loose wood into a bundle as specified.

10 5. I claim the conical gatherers  $l$ , and  $m'$ , to concentrate and compress the bundle of wood as described and shown.

15 6. I claim the stationary plate  $k$ , and segments 15, in combination with the conical gatherer  $l$ , to sustain the wood while acted on as specified.

7. I claim the plunger or press block  $m$ , acting to bring the ends of the bundle of wood level, as set forth.

20 8. I claim the vertical moving frame  $o$ , forming the receptacle for the wire, and the guide for the apparatus that wraps said wire around the bundle of wood as set forth.

9. In combination with the frame  $o$ , I claim the chain 28, to wrap the wire around

the bundle of wood and the clamp  $s'$ , to hold 25 the wire near the middle part thereof as described and shown.

10. I claim the circular twisting jaws 30, moving in dovetails and acting when revolved by competent means to twist the ends 30 of the wires together in the manner and for the purposes specified.

11. I claim the arrangement of the sliding and revolving shaft  $t$ , in combination with the twisting jaws 30, for the purposes and 35 as set forth.

12. I claim the spring guides 25, to keep the wire straight while passed into the machine in combination with the traveling jaw or clamp  $p$ , and with the shear 26, as de- 40 scribed and shown.

In witness whereof I have hereunto set my signature this eleventh day of June 1859.

W. L. WILLIAMS.

Witnesses:

LEMUEL W. SERRELL,  
THOS. GEO. HAROLD.