



(86) Date de dépôt PCT/PCT Filing Date: 2004/06/25  
 (87) Date publication PCT/PCT Publication Date: 2005/02/24  
 (45) Date de délivrance/Issue Date: 2008/06/10  
 (85) Entrée phase nationale/National Entry: 2006/02/14  
 (86) N° demande PCT/PCT Application No.: GB 2004/002732  
 (87) N° publication PCT/PCT Publication No.: 2005/017309  
 (30) Priorité/Priority: 2003/08/08 (US10/638,042)

(51) Cl.Int./Int.Cl. *E21B 33/16* (2006.01),  
*E21B 29/00* (2006.01), *E21B 33/12* (2006.01),  
*E21B 43/10* (2006.01)  
 (72) Inventeurs/Inventors:  
 RODDY, CRAIG W., US;  
 BADALAMENTI, ANTHONY M., US  
 (73) Propriétaire/Owner:  
 HALLIBURTON ENERGY SERVICES, INC., US  
 (74) Agent: OGILVY RENAULT LLP/S.E.N.C.R.L.,S.R.L.

(54) Titre : APPAREIL ET PROCEDES PERMETTANT DE PREVENIR OU DE LIMITER LA ROTATION DE BOUCHONS DE CIMENTATION

(54) Title: APPARATUS AND METHODS FOR PREVENTING OR LIMITING ROTATION OF CEMENTING PLUGS

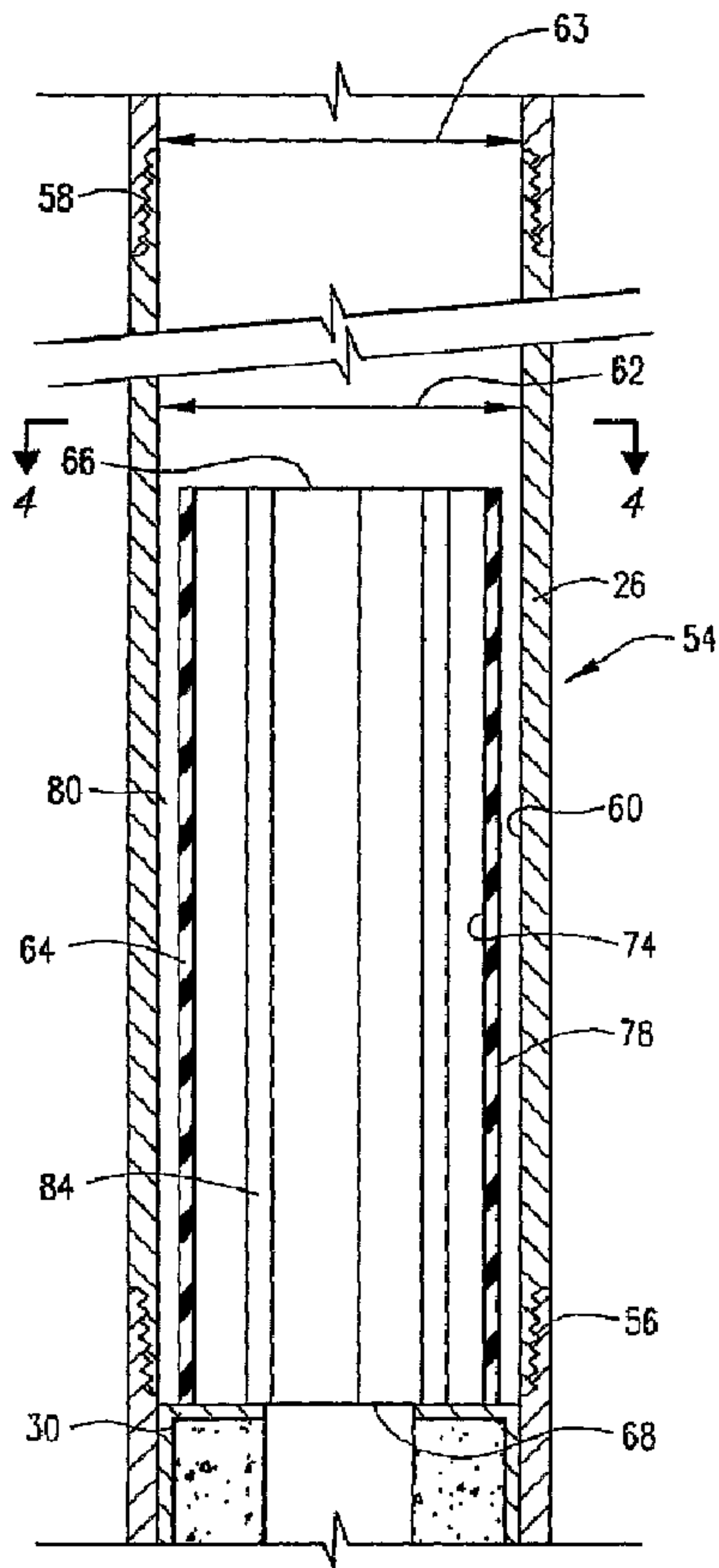

(57) Abrégé/Abstract:

Methods and apparatus for preventing or limiting the rotation of downhole tools, such as cementing plugs, in a casing string during drillout. The apparatus includes an outer case (26) and a radially expandable sleeve (64) disposed therein. The sleeves will engage

(57) **Abrégé(suite)/Abstract(continued):**

cementing plugs (22,24) received therein. The sleeves radially expand when cementing plugs are received therein to grippingly engage the outer case and prevent or limit rotation thereof during drillout.

(12) INTERNATIONAL APPLICATION PUBLISHED UNDER THE PATENT COOPERATION TREATY (PCT)

(19) World Intellectual Property  
Organization  
International Bureau



(43) International Publication Date  
24 February 2005 (24.02.2005)

PCT

(10) International Publication Number  
**WO 2005/017309 A1**

- (51) International Patent Classification<sup>7</sup>: **E21B 29/00**, 33/12, 33/16
- (21) International Application Number: PCT/GB2004/002732
- (22) International Filing Date: 25 June 2004 (25.06.2004)
- (25) Filing Language: English
- (26) Publication Language: English
- (30) Priority Data: 10/638,042 8 August 2003 (08.08.2003) US
- (71) Applicant (for all designated States except US): **HAL-LIBURTON ENERGY SERVICES, INC.** [US/US]; P.O. Box 1431, Duncan, OK 73533 (US).
- (71) Applicant (for MW only): **WAIN, Christopher, Paul** [GB/GB]; A.A. Thornton & Co., 235 High Holborn, London WC1V 7LE (GB).
- (72) Inventors; and
- (75) Inventors/Applicants (for US only): **RODDY, Craig, W.** [US/US]; 2906 Timber Ridge Drive, Duncan, OK 73533 (US). **BADALAMENTI, Anthony, M.** [US/US]; 5426 Portage Rock Lane, Katy, TX 77450 (US).
- (74) Agents: **WAIN, Christopher, Paul** et al.; A A Thornton & Co, 235 High Holbon, London WC1V 7LE (GB).
- (81) Designated States (unless otherwise indicated, for every kind of national protection available): AE, AG, AL, AM, AT, AU, AZ, BA, BB, BG, BR, BW, BY, BZ, CA, CH, CN, CO, CR, CU, CZ, DE, DK, DM, DZ, EC, EE, EG, ES, FI, GB, GD, GE, GH, GM, HR, HU, ID, IL, IN, IS, JP, KE, KG, KP, KR, KZ, LC, LK, LR, LS, LT, LU, LV, MA, MD, MG, MK, MN, MW, MX, MZ, NA, NI, NO, NZ, OM, PG, PH, PL, PT, RO, RU, SC, SD, SE, SG, SK, SL, SY, TJ, TM, TN, TR, TT, TZ, UA, UG, US, UZ, VC, VN, YU, ZA, ZM, ZW.
- (84) Designated States (unless otherwise indicated, for every kind of regional protection available): ARIPO (BW, GH,

[Continued on next page]

(54) Title: APPARATUS AND METHODS FOR PREVENTING OR LIMITING ROTATION OF CEMENTING PLUGS

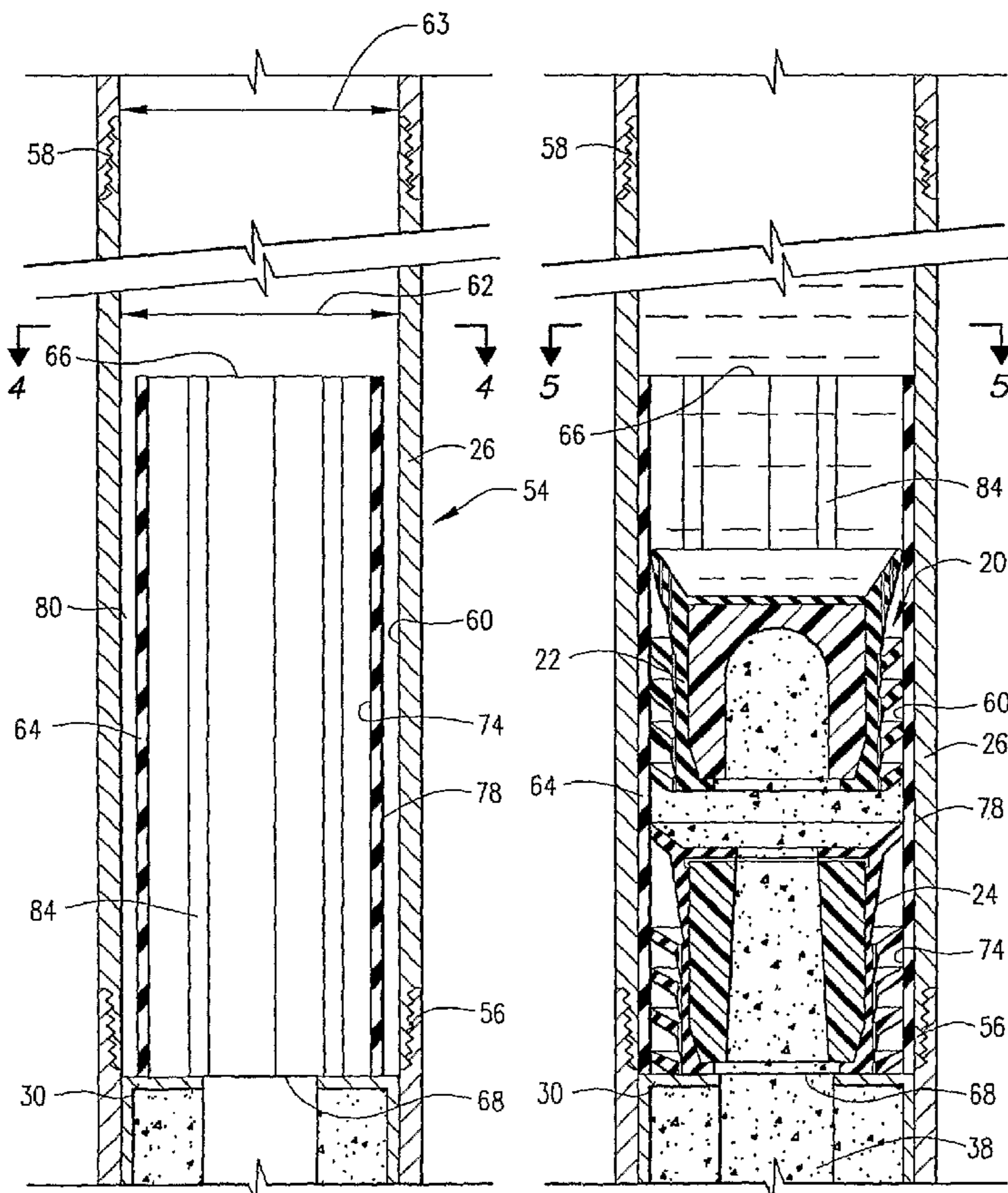

(57) Abstract: Methods and apparatus for preventing or limiting the rotation of downhole tools, such as cementing plugs, in a casing string during drillout. The apparatus includes an outer case (26) and a radially expandable sleeve (64) disposed therein. The sleeves will engage cementing plugs (22,24) received therein. The sleeves radially expand when cementing plugs are received therein to grippingly engage the outer case and prevent or limit rotation thereof during drillout.

WO 2005/017309 A1

**WO 2005/017309 A1**



GM, KE, LS, MW, MZ, NA, SD, SL, SZ, TZ, UG, ZM, ZW), Eurasian (AM, AZ, BY, KG, KZ, MD, RU, TJ, TM), European (AT, BE, BG, CH, CY, CZ, DE, DK, EE, ES, FI, FR, GB, GR, HU, IE, IT, LU, MC, NL, PL, PT, RO, SE, SI, SK, TR), OAPI (BF, BJ, CF, CG, CI, CM, GA, GN, GQ, GW, ML, MR, NE, SN, TD, TG).

**Published:**

— *with international search report*

*For two-letter codes and other abbreviations, refer to the "Guidance Notes on Codes and Abbreviations" appearing at the beginning of each regular issue of the PCT Gazette.*

## **APPARATUS AND METHODS FOR PREVENTING OR LIMITING ROTATION OF CEMENTING PLUGS**

The present invention relates generally to drilling and completion techniques for downhole wells and, more particularly, to apparatus and methods for preventing or limiting rotation of downhole tools, such as cementing plugs, while being drilled out.

In the construction of oil and gas wells, a wellbore is drilled into one or more subterranean formations or zones containing oil and/or gas to be produced. During a wellbore drilling operation, drilling fluid (also called drilling mud) is circulated through the wellbore by pumping it down the drill string, through a drill bit connected thereto and upwardly back to the surface to the annulus between the walls of the wellbore and the drill string. The circulation of the drilling fluid functions to lubricate the drill bit, remove cuttings from the wellbore as they are produced and to exert hydrostatic pressure on pressurized fluid contained formations penetrated by the wellbore whereby blowouts are prevented.

In most instances, after the wellbore is drilled, the drill string is removed and a casing string is run into the wellbore while maintaining sufficient drilling fluid in the wellbore to prevent blowouts. The term "casing string" is used herein to mean any string of pipe which is lowered into and cemented in a wellbore including but not limited to surface casing, liners and the like.

Typically, at the beginning of a cementing job, the casing and hole are filled with drilling mud. Very often, a bottom cementing plug is pumped ahead of the cement slurry to reduce contamination at the interface between the mud and cement. The bottom plug is typically constructed to have elastomeric wipers to wipe the casing of drilling mud and thereby separate the drilling mud ahead of the bottom plug from the cement slurry behind the bottom plug. Examples of cementing plugs are taught in U.S. Patent Nos. 5,722,491 and 6,196,311. The casing string will have a landing platform for the bottom plug. The landing platform may be a float collar, a float shoe or a shoulder in the casing string or other tool for stopping the bottom plug. When the bottom plug seats upon the landing platform, the fluid pressure differential created across the bottom plug ruptures a diaphragm at the top of the bottom plug and allows the cement slurry to proceed down the casing through the plug, through the float equipment at the lower end of the casing and up the annular space between the casing and the wellbore.

Once the required amount of cement has been displaced into the well, a top cementing plug, which will likewise have wipers thereon, may be displaced into the casing. The top cementing plug will follow the cement slurry into the casing, and is designed to reduce the possibility of any contamination or channeling of the cement slurry with drilling fluid or other fluid that is used to displace the cement column down into the casing and into the annular space between the casing and the wellbore. The top cementing plug does not have a fluid passage therethrough such that when it reaches the bottom cementing plug, the top cementing plug will cause a shut off of fluids being pumped through the casing.

Once the cement has set up and any other desired operations have been performed, the cementing plugs, along with float equipment therebelow, may be drilled out. In order to do so, the drill string with the drill bit thereon is lowered into the hole until the drill bit engages the top plug and is rotated. In many instances, however, when the drill bit is rotated, the top plug also begins to rotate on top of the bottom plug, or the bottom plug may rotate on the landing platform, whether the platform is float equipment or a shoulder or other restriction in the casing. Plug rotation can cost valuable time and therefore can have an economic impact on the cost of the well. Thus, there is a need to eliminate or at least limit the rotation of the cementing plugs while they are being drilled out after the cementing job. Several attempts have been made at preventing the rotation of cementing plugs. One such attempt is described in U.S. Patent No. 6,425,442 B1, entitled Anti-Rotation Device for Use with Well Tools. A drillable, non-metallic, non-rotating plug set for use in well cementing operations is described in U.S. Patent No. 5,095,980. Other devices and/or methods are shown in U.S. Patent Nos. 5,390,736; 5,165,474; and 4,190,111. United States Patent No. 6,796,377 filed July 23, 2002 assigned to the assignee of the present application, also addresses such concerns. Although the apparatus and methods described therein may in some cases work well to prevent or limit rotation of cementing plugs while being drilled out, there is a continuing need for improved anti-rotation apparatus and methods which will prevent or limit the rotation of the cementing plugs while being drilled out and which are easy to use, efficient and inexpensive.

#### SUMMARY OF THE INVENTION

The present invention provides apparatus and methods for preventing, or at least limiting, the rotation of a cementing plug or plugs while being drilled out. The apparatus includes an outer case, such as a joint of casing string, having an expandable inner sleeve

disposed therein. The inner sleeve has an open upper end and an open lower end and is adapted to receive cementing plugs displaced through a casing string during a cementing job. The inner sleeve is constructed to radially expand and engage the outer case when the cementing plug(s) is received therein. Preferably, the inner sleeve has overlapping longitudinal edges that will slide relative to one another when the inner sleeve receives a plug and expands radially to engage the outer case. Thus, the apparatus restricts rotation of cementing plug(s) by engaging the plug(s) that are received therein so that when rotational drilling forces are applied, rotation of the plug is prevented or limited.

In a preferred embodiment, the inner surface of the inner sleeve is configured and dimensioned so as to cause an interference fit, and thus, frictionally engage one or more cementing plugs that are received therein. Means for limiting rotation of the plug(s) relative to the inner surface of the inner sleeve are taught in U.S. Patent No. 6,425,442 B1 and U.S. Patent No. 6,796,377 filed July 23, 2002. Engagement between the cementing plugs and the inner sleeve, and between the inner sleeve and the outer case will prevent or limit rotation of the cementing plugs while being drilled out after a cementing job. The inner sleeve is preferably comprised of a durable, drillable material selected from the group of rubbers, elastomers, plastics, wood, drillable metals or any other drillable material that is suitable for downhole use. The inner sleeve can be made to accommodate various desired lengths such as for one plug, two plugs, or multiple plug operations.

Other and further objects, features and advantages of the present invention will be readily apparent to those skilled in the art upon reading of the description of preferred embodiments which follows.

#### BRIEF DESCRIPTION OF THE DRAWINGS

FIG. 1 shows a side cross-sectional view of a prior art plug set displaced into a casing.

FIG. 2 shows a side cross-sectional view of an anti-rotation apparatus of the present invention.

FIG. 3 shows a side cross-sectional view of the anti-rotation apparatus of FIG. 2 with cementing plugs received therein.

FIG. 4 shows a view from line 4-4 of FIG. 2.

FIG. 5 shows a view from line 5-5 of FIG. 3.

FIG. 6 shows a side cross-sectional view of an additional embodiment of an anti-rotation apparatus of the present invention wherein the inner sleeve has a continuous outer diameter.

FIG. 7 shows a side cross-sectional view of an additional embodiment of an anti-rotation apparatus of the present invention wherein the diameter of the inner surface of the inner sleeve tapers radially inwardly from the upper end to lower end thereof.

FIG. 8 shows a side cross-sectional view of an additional embodiment of an anti-rotation apparatus of the present invention wherein the inner sleeve has an outer diameter that tapers inwardly from the upper end to lower end thereof.

FIG. 9 shows a side cross-sectional view of an additional embodiment of an anti-rotation apparatus of the present invention wherein the inner sleeve has a plurality of slits.

#### DESCRIPTION OF PREFERRED EMBODIMENTS

The present invention provides improved anti-rotation apparatus and methods for preventing or limiting plug rotation in wellbore operations, e.g., oil and gas well cementing operations. Referring now to the drawings and more particularly to FIG. 1, a prior art cementing plug set 20 is shown. Plug set 20 includes a top cementing plug 22 and a bottom cementing plug 24. The plug set 20 is shown in an outer case or casing 26 such as a joint of casing string or pipe string, in a preferred embodiment, a steel, non-drillable string of cylindrical oilfield casing being cemented into a wellbore 28. Plug set 20 is shown after bottom cementing plug 24 has landed on a landing platform 30 which may comprise a float collar, float shoe or other float equipment, or any other restriction which will allow bottom cementing plug 24 to land, but which will also allow fluid flow therethrough. Bottom cementing plug 24 comprises a body 32 defining a flow passage 34 therethrough. Typically, a rupturable member 36 will be disposed across the top of flow passage 34 such that when bottom cementing plug 24 lands, increasing fluid pressure will cause the rupturable member 36 to burst so that fluid, such as a cement slurry 38, can flow through flow passage 34. In FIG. 1, the rupturable member has already been ruptured to allow flow through flow passage 34. Bottom cementing plug 24 also includes an elastomeric cover 40 disposed about body 32. Elastomeric cover 40 includes a plurality of wipers 42. As explained above, bottom cementing plug 24 will normally be placed in the casing 26 ahead of the cement slurry 38 to wipe off the inner surface of the casing 26 and separate the drilling fluid from the cement slurry 38. Top cementing plug 22 has a body 44 with an elastomeric cover 46 disposed

thereabout. Elastomeric cover 46 includes elastomeric wipers 48. Body 44 defines a central cavity 50.

Top cementing plug 22 is displaced into the casing 26 above the cement slurry 38 to separate the cement slurry 38 from the drilling or other fluids thereabove utilized to urge the cement slurry 38 downwardly through the casing 26 and into the annulus 52 between casing 26 and the wellbore 28. FIG. 1 shows top cementing plug 22 prior to the time it engages and seats upon bottom cementing plug 24.

Referring now to FIG. 2, a preferred apparatus 54 of the present invention for limiting rotation of a cementing plug or plug set 20 when rotational forces, such as forces applied by a drill bit during drillout, are applied is shown. Apparatus 54 includes outer case 26 which is preferably a casing joint that can be threadedly connected in and will make up a part of a casing string lowered into a wellbore 28. Outer case 26 has a lower end 56, an upper end 58 and an inner surface 60. Outer case 26 defines an inner diameter 62 that is preferably substantially identical to the inner diameter 62 of the casing string in which apparatus 54 is connected. Apparatus 54 has an inner sleeve 64 disposed in outer case 26. Inner sleeve 64 is preferably comprised of a drillable material and is radially expandable. Preferred materials for use in constructing the inner sleeve 64 include, but are not necessarily limited to, durable, drillable materials such as rubbers, elastomers, plastics, wood, drillable metals or any other drillable material that is suitable for downhole use. Furthermore, FIG. 3 shows a plug set 20 in combination with the apparatus 54.

Inner sleeve 64 has an upper end 66 and a lower end 68. Upper and lower ends 66 and 68 are open and upper end 66 is adapted to receive one or more cementing plugs, such as top and bottom cementing plugs 22 and 24. Inner sleeve 64 preferably has first and second longitudinal edges 70 and 72, respectively. Prior to cementing plugs 22 and 24 being received into inner sleeve 64, longitudinal edges 70 and 72 preferably overlap, as shown in FIG. 4. Overlapping longitudinal edges 70 and 72 will move relative to each other as inner sleeve 64 expands to engage outer case 26. Inner sleeve 64 has an inner surface 74 that defines passageway 76. Once the plugs 22 and 24 are received in the passageway 76 of inner sleeve 64, longitudinal edges 70 and 72 may continue to overlap, spread apart or be even as shown in FIG. 5.

Inner sleeve 64 has an outer surface 78. Inner sleeve 64 and outer case 26 define a space or annulus 80 therebetween. Thus, inner sleeve 64 has a smaller outer diameter than

the inner diameter 62 of outer case 26 when it is in its relaxed condition, as shown in FIG. 2, prior to the time cementing plugs 22 and 24 are received therein. Alternately, as shown in FIG 6, the inner sleeve 64 may be constructed without longitudinal edges 70 and 72 to provide a continuous outer diameter and with a drillable material that allows the inner sleeve 64 to radially expand when the plugs 22 and 24 are received therein, whereby the inner sleeve 64 expands to grip the outer case 26 to prevent rotation of the inner sleeve 64 and plugs 22 and 24 within the outer case 26.

As shown in FIG. 3, bottom cementing plug 24 has been displaced into the casing string 26 and has engaged landing platform 30 which as set forth above may comprise a float collar, a float shoe or other float equipment, or may comprise a shoulder or other restriction in the casing which provides a barrier to stop bottom cementing plug 24. Top cementing plug 22 is shown just prior to the time that it engages bottom cementing plug 24. Top and bottom cementing plugs 22 and 24 are received in the open upper end 66 of inner sleeve 64. Top and bottom cementing plugs 22 and 24 have an unrestrained outer diameter defined by the wipers 42 and 48 thereon that is greater than inner diameter 62 of the casing 26 so that the plugs 22 and 24 will effectively wipe the inner surface 60 of the casing 26 as it passes therethrough. Top and bottom cementing plugs 22 and 24 will be engaged by the inner surface 74 of the expandable inner sleeve 64 upon entering through the open upper end 66 thereof. When bottom cementing plug 24 is received in the expandable inner sleeve 64, it will engage expandable sleeve 64 and urge it radially outwardly so that it engages outer case 26.

Plugs 22 and 24 will engage the radially expandable inner sleeve 64, and expandable inner sleeve 64 will engage outer case 26 such that once the cementing job is complete, the engagement will prevent, or at least limit, the rotation of the cementing plugs 22 and 24 while being drilled out. In other words, when rotational forces, such as drilling forces, are applied to top and bottom cementing plugs 22 and 24, the expandable inner sleeve 64 will engage and hold top and bottom cementing plugs 22 and 24 in place and inner sleeve 64 will be held in place by the engagement of inner sleeve 64 with outer case 26. It is understood that any design and/or material, which prevents or limits movement between the inner sleeve 64 and outer case 26 when the sleeve 64 is radially expanded, may be used on the outer surface 78. This is preferably accomplished by utilizing elastomeric or rubber materials that can be expanded wherein the outer surface 78 will grab, or grip the inner surface 60 of outer case 26 when forced into engagement therewith by cementing plugs 22 and 24. If desired, the outer

surface 78 of the expandable inner sleeve 64 may have protrusions, grooves and/or an abrasive surface to grip inner surface 60 of outer case 26 and limit or prevent rotation of expanded inner sleeve 64 and thus the plugs 22 and 24 received therein. As shown in FIG. 5, inner sleeve 64 may also have stiffening ribs 82 made from a drillable material to prevent inner sleeve 64 from collapsing when top and bottom cementing plugs 22 and 24 are received therein. Ribs 82 may extend from the upper end 66 to the lower end 68 of inner sleeve 64.

The inner surface 74 of the expandable inner sleeve 64 preferably has protrusions 84 thereon as shown in FIG. 5 and/or, if desired, the inner diameter can be tapered radially inwardly as shown in FIG. 7 from the upper end 66 to the lower end 68 thereof, to increase the interference between cementing plugs 22 and 24 and the radially expandable inner sleeve 64. Other suitable means including, *inter alia*, grooves and abrasive surfaces for limiting rotation of the plugs 22 and 24 received in the inner sleeve 64 are taught in U.S. Patent No. 6,425,442 B1 and U.S. Patent No. 6,796,377. The engagement of plugs 22 and 24 with inner sleeve 64 and the engagement between inner sleeve 64 and outer case 26 is such that during drillout of the cementing plugs 22 and 24 rotation is prevented, or at least limited, to provide for easier drilling of the plugs 22 and 24.

An additional embodiment of an apparatus 86 of the present invention to limit, or prevent rotation during drillout is shown in FIG. 8. Apparatus 86 includes outer housing 26 and radially expandable inner sleeve 64. However, inner sleeve 64 has an outer diameter 88 that tapers inwardly from upper end 66 to lower end 68 thereof. When cementing plugs 22 and 24 are received in the open upper end 66 of the expandable inner sleeve 64, plugs 22 and 24 will cause inner sleeve 64 to expand radially outwardly as the plugs move from the upper end 66 to the lower end 68 thereof to close tapered gap 90 and cause inner sleeve 64 to grippingly engage outer case 26. The engagement between plus 22 and 24 and radially expandable inner sleeve 64 and the engagement between radially expandable inner sleeve 64 and outer case 26 will prevent or at least limit rotation of cementing plus 22 and 24 during drillout of the plugs 22 and 24. Inner sleeve 64 may have stiffening ribs 82 therein to prevent inner sleeve 64 from collapsing when it is initially engaged by cementing plugs 22 and 24.

An additional embodiment of the current invention is shown in FIG. 9. An apparatus 92 for limiting rotation of cementing plugs 22 and 24 includes outer case 26 and radially expandable inner sleeve 64. In this embodiment, radially expandable inner sleeve 64

may have a plurality of slits 94 extending for a portion of the length 96 thereof. Slits 94 preferably include a plurality of circumferentially spaced slits that extend for over at least half of the length 96. In addition, slits 94 may have a width to form slots that allow expansion. Slits 94 may include upper slits 98 that extend downwardly from upper end 66 for at least a portion of length 96 from upper end 66 and a plurality of lower slits 100 that extend upwardly from the lower end 68 of radially expandable sleeve 64 for a portion of length 96. Slits 94 will aid in the radial expansion of inner sleeve 64. It is understood that this embodiment may have an outer diameter 88 that tapers inwardly from upper end 66 to lower end 68 thereof as shown in FIG 9 or non-tapered as in the embodiment shown in FIGS. 2 and 6.

If desired, all of the embodiments described herein may have stiffening ribs 82 embedded or attached thereto that will prevent the inner sleeves 64 from collapsing upon being engaged by cementing plugs 22 and 24 and/or have either or both the inner surface 74 and outer surface 78 tapered. The inner sleeve 64 can also be made to accommodate various desired lengths such as for one plug, two plugs, or multiple plug operations.

The inner sleeves 64 may be constructed of any suitable design and/or material sufficient to provide the desired expansion and prevent or limit the plugs 22 and 24 from rotating. Additionally, all of the inner sleeves 64 may have protrusions, grooves, abrasives or other suitable limiting means on the inner surface 74 thereof to aid in preventing or limiting rotation of the cementing plugs 22 and 24 inside the inner sleeves 64. The outer surface 78 of the inner sleeves 64 may use various designs and/or materials to aid in the gripping between the inner sleeves 64 and the outer case 26. Therefore, the surface of the inner sleeve 64 will grip or frictionally engage the inner surface 60 of outer case 26 and the material and/or internal design of the inner sleeve 64 will engage the plugs 22 and 24 such that the inner sleeve 64 and plug 22 and 24 are prevented or limited from rotating during drillout.

A preferred method of completing a well utilizing the present invention comprises the steps of drilling a wellbore in a subterranean formation, placing a casing string containing the apparatus of the present invention in the wellbore, displacing a fluid or cement slurry through the casing string using one or more plugs, lodging the plugs within the inner sleeve of the apparatus thereby radially expanding the inner sleeve to grip the outer case and prevent or limit rotation of the apparatus and plugs, drilling out the apparatus and plugs, creating openings in the casing string adjacent to the formation, optionally stimulating the formation

to produce hydrocarbons, and producing hydrocarbons or other desired fluid from the formation.

Thus, the present invention is well adapted to carry out the object and advantages mentioned as well as those which are inherent therein. While numerous changes may be made by those skilled in the art, such changes are encompassed within the spirit of this invention as defined by the appended claims.

## WHAT IS CLAIMED IS:

1. An apparatus for preventing or limiting rotation of a downhole tool in a casing during drillout comprising an expandable sleeve adapted to receive and prevent or limit rotation of the tool in the casing, the sleeve expanding into contact with the casing, the friction between the sleeve and the casing arresting the rotation of the tool.
2. The apparatus of claim 1 wherein the tool is a cementing plug.
3. The apparatus of claim 1 wherein the sleeve comprises overlapping first and second longitudinal edges that slide relative to one another when the sleeve radially expands.
4. The apparatus of claim 1 wherein the sleeve comprises an inner surface that tapers radially inwardly from an upper end to a lower end thereof.
5. The apparatus of claim 1 wherein the sleeve comprises an expandable material.
6. The apparatus of claim 5 wherein the expandable material is selected from the group consisting of rubbers, elastomers, plastics, wood and drillable metals.
7. The apparatus of claim 1 wherein the sleeve comprises at least one slit extending for at least a portion of a length thereof.
8. The apparatus of claim 1 wherein the sleeve comprises a plurality of slits circumferentially spaced around the sleeve.
9. The apparatus of claim 8 wherein at least a portion of the plurality of slits extend from an upper end of the sleeve downwardly for at least a portion of a length of the sleeve.

10. The apparatus of claim 8 wherein at least a portion of the plurality of silts extend from a lower end of the sleeve upwardly for at least a portion of the length of the sleeve.
11. The apparatus of claim 1 wherein the sleeve comprises a protrusion, groove or abrasive on an inner surface thereof for engaging the tool.
12. The apparatus of claim 1 wherein the sleeve comprises a protrusion, groove or abrasive on an outer surface thereof for engaging the casing.
13. The apparatus of claim 1 wherein the sleeve tapers inwardly from an upper end to a lower end thereof.
14. The apparatus of claim 1 wherein the sleeve comprises at least one stiffening rib.
15. An apparatus for preventing or limiting rotation of a cementing plug during drillout comprising:
  - an outer case; and
  - an expandable sleeve disposed in the outer case, wherein the sleeve is adapted to receive the cementing plug and radially expand to grippingly engage the outer case when the plug is received therein.
16. The apparatus of claim 15 wherein the sleeve comprises overlapping first and second longitudinal edges that slide relative to one another when the sleeve radially expands.
17. The apparatus of claim 15 wherein the sleeve comprises an inner surface that tapers radially inwardly from an upper end to a lower end thereof.
18. The apparatus of claim 15 wherein the sleeve comprises an expandable material.

19. The apparatus of claim 18 wherein the expandable material is selected from the group consisting of rubbers, elastomers, plastics, wood and drillable metals.
20. The apparatus of claim 15 wherein the sleeve comprises at least one slit extending for at least a portion of a length thereof.
21. The apparatus of claim 15 wherein the sleeve comprises a plurality of slits circumferentially spaced around the sleeve.
22. The apparatus of claim 21 wherein at least a portion of the plurality of slits extend from an upper end of the sleeve downwardly for at least a portion of a length of the sleeve.
23. The apparatus of claim 21 wherein at least a portion of the plurality of slits extend from a lower end of the sleeve upwardly for at least a portion of the length of the sleeve.
24. The apparatus of claim 15 wherein the sleeve comprises a protrusion, groove or abrasive on an inner surface thereof for engaging the plug.
25. The apparatus of claim 15 wherein the sleeve comprises a protrusion, groove or abrasive on an outer surface thereof for engaging the casing.
26. The apparatus of claim 15 wherein the sleeve tapers inwardly from an upper end to a lower end thereof.
27. The apparatus of claim 15 wherein the sleeve comprises at least one stiffening rib.
28. An apparatus for preventing or limiting rotation of a cementing plug in a casing string comprising an expandable sleeve adapted to receive the plug therein and means

for preventing or limiting rotation of the plug in the sleeve, the sleeve being expandable into contact with the casing for contributing in arresting the plug against rotation.

29. The apparatus of claim 28 wherein the sleeve comprises overlapping first and second longitudinal edges that slide relative to one another when the sleeve radially expands.

30. The apparatus of claim 28 wherein the means for preventing or limiting rotation of the plug comprises an inner surface of the sleeve that tapers radially inwardly from an upper end to a lower end thereof.

31. The apparatus of claim 28 wherein the sleeve comprises an expandable material.

32. The apparatus of claim 31 wherein the expandable material is selected from the group consisting of rubbers, elastomers, plastics, wood and drillable metals.

33. The apparatus of claim 28 wherein the sleeve comprises at least one slit extending for at least a portion of a length thereof.

34. The apparatus of claim 28 wherein the sleeve comprises a plurality of slits circumferentially spaced around the sleeve.

35. The apparatus of claim 34 wherein at least a portion of the plurality of slits extend from the upper end of the sleeve downwardly for at least a portion of a length of the sleeve.

36. The apparatus of claim 34 wherein at least a portion of the plurality of slits extend from a lower end of the sleeve upwardly for at least a portion of the length of the sleeve.

37. The apparatus of claim 28 wherein the means for preventing or limiting rotation of the plug comprises a protrusion, groove or abrasive on an inner surface thereof for engaging the plug.
38. The apparatus of claim 28 wherein the sleeve comprises a protrusion, groove or abrasive on an outer surface thereof for engaging the casing.
39. The apparatus of claim 28 wherein the sleeve tapers inwardly from an upper end to a lower end thereof.
40. The apparatus of claim 28 wherein the sleeve comprises at least one stiffening rib.
41. A method for preventing or limiting rotation of a plug in a casing located in a wellbore comprising the steps of:  
providing a casing having an expandable sleeve disposed therein;  
placing the casing in a wellbore;  
displacing the plug through the casing; and  
engaging the sleeve with the plug wherein the sleeve radially expands and grippingly engages the casing so that the plug and sleeve resist rotation during drillout.
42. The method of claim 41 wherein the sleeve comprises overlapping first and second longitudinal edges that slide relative to one another when the sleeve radially expands.
43. The method of claim 41 wherein the sleeve comprises an inner surface that tapers radially inwardly from an upper end to a lower end thereof.
44. The method of claim 41 wherein the sleeve comprises an expandable material.
45. The method of claim 44 wherein the expandable material is selected from the group consisting of rubbers, elastomers, plastics, wood and drillable metals.

46. The method of claim 41 wherein the sleeve comprises at least one slit extending for at least a portion of a length thereof.
47. The method of claim 41 wherein the sleeve comprises a plurality of slits circumferentially spaced around the sleeve.
48. The method of claim 47 wherein at least a portion of the plurality of slits extend from an upper end of the sleeve downwardly for at least a portion of a length of the sleeve.
49. The method of claim 47 wherein at least a portion of the plurality of slits extend from a lower end of the sleeve upwardly for at least a portion of the length of the sleeve.
50. The method of claim 41 wherein the sleeve comprises a protrusion, groove or abrasive on an inner surface thereof for engaging the plug.
51. The method of claim 41 wherein the sleeve comprises a protrusion, groove or abrasive on an outer surface thereof for engaging the casing.
52. The method of claim 41 wherein the sleeve tapers inwardly from an upper end to a lower end thereof.
53. The method of claim 41 wherein the sleeve comprises at least one stiffening rib.
54. The method of claim 41 further comprising the step of drilling out the sleeve and plug.
55. A method of constructing a well comprising the steps of:  
drilling a wellbore in a subterranean formation;

placing a casing having an expandable sleeve disposed therein in the wellbore, wherein the sleeve is adapted to receive and prevent or limit rotation of a downhole tool in the casing;

disposing the tool within the sleeve thereby expanding the sleeve to engage the casing; and

drilling out the sleeve and tool.

56. The method of claim 55 wherein the tool is a cementing plug.

57. The method of claim 55 wherein the sleeve comprises overlapping first and second longitudinal edges that slide relative to one another when the sleeve radially expands.

58. The method of claim 55 wherein the sleeve comprises an inner surface that tapers radially inwardly from an upper end to a lower end thereof.

59. The method of claim 55 wherein the sleeve comprises an expandable material.

60. The method of claim 59 wherein the expandable material is selected from the group consisting of rubbers, elastomers, plastics, wood and drillable metals.

61. The method of claim 55 wherein the sleeve comprises at least one slit extending for at least a portion of a length thereof.

62. The method of claim 55 wherein the sleeve comprises a plurality of slits circumferentially spaced around the sleeve.

63. The method of claim 62 wherein at least a portion of the plurality of slits extend from an upper end of the sleeve downwardly for at least a portion of a length of the sleeve.

64. The method of claim 62 wherein at least a portion of the plurality of slits extend from a lower end of the sleeve upwardly for at least a portion of the length of the sleeve.
65. The apparatus of claim 55 wherein the sleeve comprises a protrusion, groove or abrasive on an inner surface thereof for engaging the tool.
66. The apparatus of claim 55 wherein the sleeve comprises a protrusion, groove or abrasive on an outer surface thereof for engaging the casing.
67. The method of claim 55 wherein the sleeve tapers inwardly from an upper end to the lower end thereof.
68. The method of claim 55 wherein the sleeve comprises at least one stiffening rib.
69. The method of claim 55 further comprising the step of creating openings in the casing adjacent to the formation.
70. The method of claim 55 further comprising the step of stimulating the formation to produce hydrocarbons.
71. The method of claim 55 further comprising the step of producing a fluid from the formation.
72. The method of claim 55 further comprising the step of producing hydrocarbons from the formation.





