

W. MATHESIUS.
HOT BLAST STOVE.
APPLICATION FILED OCT. 10, 1911.

1,018,331.

Patented Feb. 20, 1912.

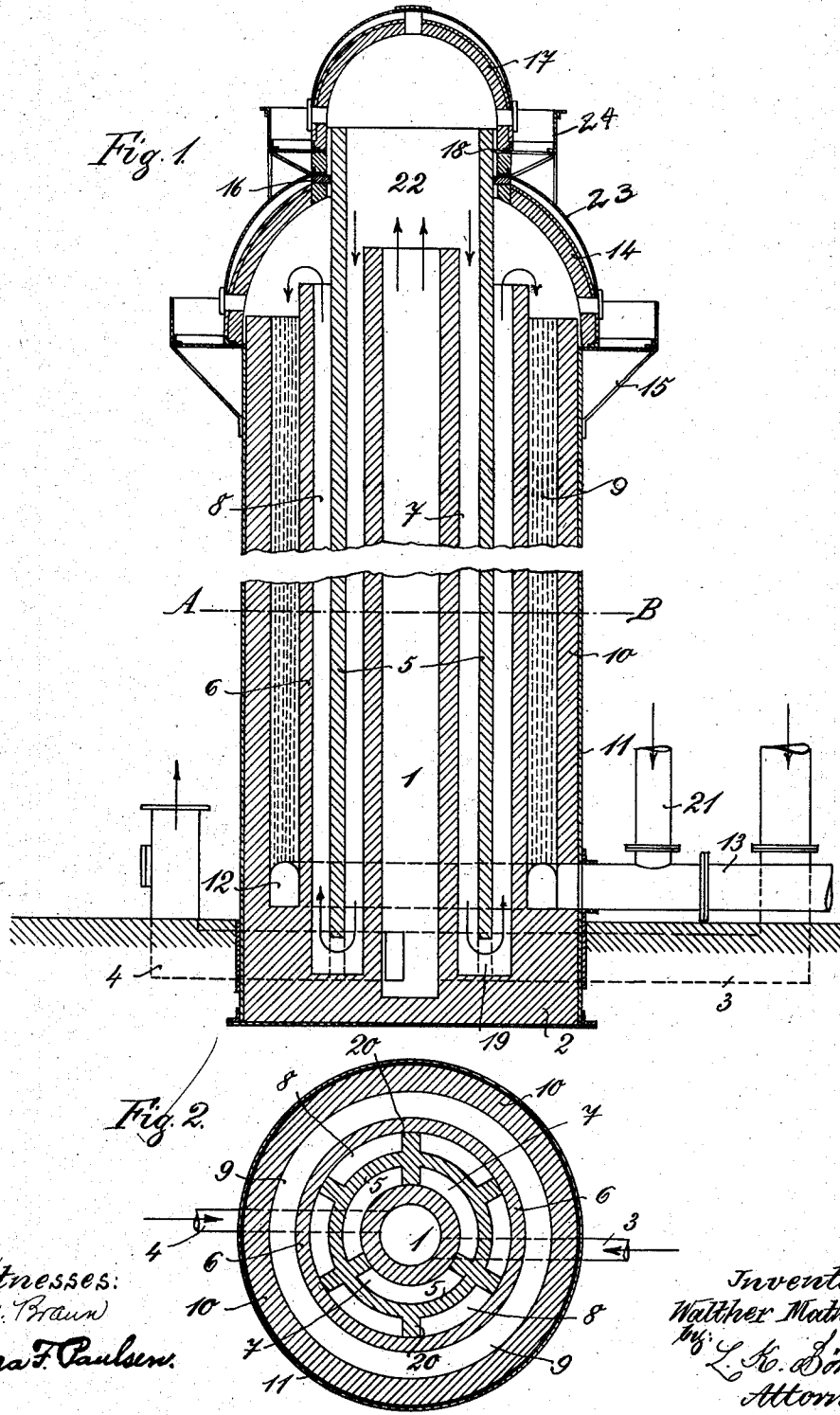

Witnesses:
M. O. Braun
Vera F. Paulsen.

Inventor:
Walter Mathesius
By L. K. Bohm
Attorney

UNITED STATES PATENT OFFICE.

WALTHER MATHESIUS, OF CHARLOTTENBURG, GERMANY.

HOT-BLAST STOVE.

1,018,331.

Specification of Letters Patent. Patented Feb. 20, 1912.

Application filed October 10, 1911. Serial No. 653,844.

To all whom it may concern:

Be it known that I, WALTHER MATHESIUS, a subject of the King of Prussia, and resident of 10 Carmerstrasse, Charlottenburg, near Berlin, German Empire, have invented certain new and useful Improvements in Hot-Blast Stoves, of which the following is a specification.

This invention relates to certain improvements in hot blast stoves of the Cowper type but in which the combustion chamber is arranged centrally in the apparatus so as to reduce the loss due to radiation of heat, and in which the combustion chamber is surrounded by concentric annular flues through which the gases pass in a zig-zag course, an inner cupola or dome for directing the path of the gases being provided within the usual outer cupola.

Heretofore the practical utility of apparatus of this type has been frustrated owing to the fact that the inner cupola was not held rigidly in position independently of the walls of the flues, but was carried by the latter, so that the flue walls were subjected to too great a load, which resulted in leakages and in a diminished efficiency of the stove.

According to the present invention I continue one or more of the flues upwardly through the outer or larger cupola and fit a smaller cupola on the top of said elongated flues, a tight stuffing-joint being formed between the elongated flues and the cupolas. The latter are moreover carried by the outer iron shell of the stove so that the flue walls only require to support their own weight.

My invention also comprises means for creating as long a flame as possible in the combustion chamber so as to attain better utilization of the heat from the combustion. For this purpose the furnace gases and the air for combustion are not admitted radially into the combustion chamber, as is usually the case, but are admitted tangentially and at or approximately parallel to one another so that the flame takes a spirally upward course, thus increasing the length of the combustible zone as much as possible. In this manner the mixture of the hot gases with air is retarded so that local overheating is obviated.

In order that the invention may be more clearly understood, reference is made to the accompanying drawings, which show, by

way of example, a preferred construction of my improved hot blast stove.

Figure 1 is a vertical section, the center part being broken away, and Fig. 2 is a transverse section on the line A—B of Fig. 1.

The stove comprises a cylindrical combustion chamber 1, the walls of which are carried by the lower masonry 2 and opening tangentially into the lower part of the combustion chamber 1 are conduits 3 and 4, the conduit 3 serving for the admission of the furnace gases and the conduit 4 for air for combustion. Surrounding the combustion chamber 1 are annular flue walls 5 and 6 forming flue spaces 7 and 8 respectively, and around the outer flue wall 6 is provided checkered brickwork 9 between the wall 6 and an outer wall 10, which latter is surrounded by the iron shell 11. Below the checkered brickwork 9 is a flue space 12 communicating through a conduit 13 with the chimney. As will be readily seen from Fig. 1, the flue wall 5 is continued upwardly and passes centrally through the larger cupola 14 which is supported on a framework 15 carried by the outer shell 11, the joint between the flue wall 5 and cupola 14 being packed by means of a ring 16 so that the wall 5 is free to slide therethrough while forming a gas tight joint. The iron framework 15 also carries an outer iron shell 23 and a gauntree 24 which support a smaller cupola 17 fitting over the flue wall 5 and if desired the space 18 between the cupola 17 and wall 5 may also be packed. The walls 5 and 6 are supported by the lower masonry 2 and the wall 5 cut away below at 19 to provide communication between the flues 7 and 8. The wall 5 also carries supporting webs 20 whereby the whole internal structure is supported in position.

21 is the cold air blast inlet pipe.

From the foregoing description it will be readily understood that the gas and air entering the combustion chamber 1 by way of the conduits 3 and 4, the flame will rise in a spiral path in the chamber and thus come into close contact with the wall of the chamber 1 and rising therein, complete combustion will take place in the space 22 in the upper part of the stove, the gases passing down the flue 7 and through the opening 19 into the flue 8. The gases rising therein will then pass down through the checkered

brickwork 9 to the chimney. By this means the heat from the combustion of the gases is fully utilized while the flue walls 5, 6 and 10 and the wall of the chamber 1 only require to support their own weight, as the cupolas 14 and 17 are carried by the iron shell 11. As the smaller cupola 17 is only about half the diameter of the cupola 14 the radiation of heat therefrom is only about one fourth that of the cupolas of the Cowper stove now in general use.

As the wall of the combustion chamber 1 terminates some distance below the flue wall 5, the gases have opportunity to fully mix in the large space 22 thus available and can complete their combustion therein. The stuffing-box form of joint between the flue wall 5 and the cupolas prevents the gases escaping and also enables free expansion and contraction of the parts relatively to one another.

It has been found that the temperature of the gases in the cupola 14 seldom exceeds 800° C. so that the loss due to radiation is still further reduced.

It will thus be seen that a stove is obtained in which leakage is obviated and the life and efficiency of which are considerably increased as compared with previous constructions.

I claim:—

1. A hot blast stove comprising a central combustion chamber to which the furnace gases and air may be supplied, an outer con-

centric cylindrical wall projecting above the combustion chamber, an annular flue being formed between said wall and combustion chamber, outer concentric annular flues communicating with the inner flue, an outer iron shell, a centrally apertured dome supported by said shell, said cylindrical wall passing through said dome, an expansible joint between said dome and cylindrical wall and a cupola fitted over said cylindrical wall and supported by said outer iron shell.

2. In a hot blast stove, a cylindrical combustion chamber, means for supplying air and gases to the combustion chamber so as to increase the length of the flame and cause the same to rise spirally in said chamber, comprising air and gas conduits opening tangentially into the lower part of said chamber.

3. In a hot blast stove, a cylindrical combustion chamber, means for supplying air and gases to the combustion chamber so as to increase the length of the flame and cause the same to rise spirally in said chamber, comprising air and gas conduits opening in parallel directions and tangentially into the lower part of said chamber.

In witness whereof I have hereunto set my hand in the presence of two witnesses.

WALTHER MATHESIUS.

Witnesses:

HENRY HASPER,
WOLDEMAR HAUPT.