

(19) World Intellectual Property
Organization
International Bureau



(43) International Publication Date
27 December 2002 (27.12.2002)

PCT

(10) International Publication Number
WO 2002/103151 A3

- (51) International Patent Classification⁷: **F16J 15/16**, 15/32 (74) Agent: JACKSON, James, L.; Andrews & Kurth, L.L.P., Suite 4200, 600 Travis, Houston, TX 77002-2778 (US).
- (21) International Application Number: PCT/US2002/011279 (81) Designated State (*national*): CA.
- (22) International Filing Date: 10 April 2002 (10.04.2002) (84) Designated States (*regional*): European patent (AT, BE, CH, CY, DE, DK, ES, FI, FR, GB, GR, IE, IT, LU, MC, NL, PT, SE, TR).
- (25) Filing Language: English
- (26) Publication Language: English
- (30) Priority Data: 09/834,330 12 April 2001 (12.04.2001) US
- (71) Applicant: KALSI ENGINEERING, INC. [US/US]; 745 Park Two Drive, Sugar Land, TX 77478 (US).
- (72) Inventors: KALSI, Manmohan, S.; 13307 Carousel Court, Houston, TX 77041 (US). DIETLE, Lannie, L.; 805 Lakeview Drive, Sugar Land, TX 77478 (US). GOBELI, Jeffrey, D.; 10614 Overbrook Lane, Houston, TX 77042 (US).
- Published:
— with international search report
— before the expiration of the time limit for amending the claims and to be republished in the event of receipt of amendments
- (88) Date of publication of the international search report: 12 August 2004
- For two-letter codes and other abbreviations, refer to the "Guidance Notes on Codes and Abbreviations" appearing at the beginning of each regular issue of the PCT Gazette.

(54) Title: HYDRODYNAMIC ROTARY SEAL WITH VARYING SLOPE

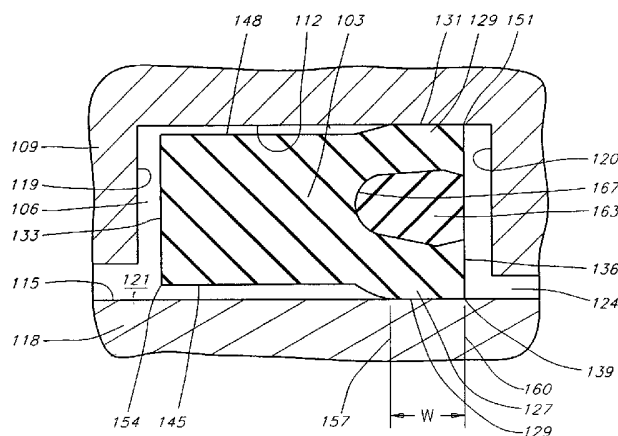

(57) Abstract: A hydrodynamically lubricating seal has a generally circular seal body (103) defining a static sealing surface (131) and having a dynamic sealing lip (127) projecting from the seal body for establishing sealing relation with a relatively rotatable surface (115), dynamic sealing lip defines a hydrodynamic geometry which wedges a film of lubricating fluid into the interface between the seal and the relatively rotatable surface in response to relative rotation. The dynamic sealing lip geometry maintains interfacial contact pressure within the dynamic sealing interface for efficient hydrodynamic lubrication and environmental exclusion, which enhances lubrication and environmental exclusion while permitting relatively high initial compression and relatively low torque. In abrasive environments, the improved exclusionary action results in a dramatic reduction of seal and shaft wear, compared to prior art, and provides a significant increase in seal life. The invention also increases seal life by making higher levels of initial compression possible, compared to prior art, without compromising hydrodynamic lubrication. This added compression makes the seal more tolerant of compression set, abrasive wear, mechanical misalignment, dynamic runout and manufacturing tolerances.

WO 2002/103151 A3

INTERNATIONAL SEARCH REPORT

International application No.

PCT/US02/11279

A. CLASSIFICATION OF SUBJECT MATTER

IPC(7) : F16J 15/16,15/32
 US CL : 277/559, 560, 572, 273, 574, 584

According to International Patent Classification (IPC) or to both national classification and IPC

B. FIELDS SEARCHED

Minimum documentation searched (classification system followed by classification symbols)
 U.S. : 277/559, 560, 572, 273, 574, 584

Documentation searched other than minimum documentation to the extent that such documents are included in the fields searched

Electronic data base consulted during the international search (name of data base and, where practicable, search terms used)

C. DOCUMENTS CONSIDERED TO BE RELEVANT

Category *	Citation of document, with indication, where appropriate, of the relevant passages	Relevant to claim No.
X --- Y	US 4,610,319 A (Kalsi) 09 September 1986 (09.09.1986), see entire document.	1-5, 13-16, 18-21, 23-24, 27-31, 34, 35, 38-39, 42-43, and 45
Y	US 5738,358 A (Kalsi et al) 14 April 1998 (14.04.1998), see entire document.	6-12, 17, 20-22, 25-26, 29, 32, 35-37, 40-41, 44, 46-47 and 48-50
Y	US 3,929,340 A (Peisker) 30 December 1975 (30.12.1975), see entire document.	6-7, 8, 25-26, 40-41 and 46-47
Y	US 4,328,972 A (Albertson et al) 11 May 1982 (11.05.1982), see entire document.	10-12, 20-22, 29, 35-37, 44 and 50
Y	US 4,328,972 A (Albertson et al) 11 May 1982 (11.05.1982), see entire document.	9 and 33
A	US 4,094,519 A (Heyn et al) 13 June 1978 (13.06.1978), see entire document.	1-50
A	US 5,190,299 A (Johnston) 02 March 1993 (02.03.1993), see entire document.	1-50

Further documents are listed in the continuation of Box C. See patent family annex.

* Special categories of cited documents:	"T"	later document published after the international filing date or priority date and not in conflict with the application but cited to understand the principle or theory underlying the invention
"A" document defining the general state of the art which is not considered to be of particular relevance	"X"	document of particular relevance; the claimed invention cannot be considered novel or cannot be considered to involve an inventive step when the document is taken alone
"E" earlier application or patent published on or after the international filing date	"Y"	document of particular relevance; the claimed invention cannot be considered to involve an inventive step when the document is combined with one or more other such documents, such combination being obvious to a person skilled in the art
"L" document which may throw doubts on priority claim(s) or which is cited to establish the publication date of another citation or other special reason (as specified)	"Z"	document member of the same patent family
"O" document referring to an oral disclosure, use, exhibition or other means		
"P" document published prior to the international filing date but later than the priority date claimed		

Date of the actual completion of the international search 10 October 2002 (10.10.2002)	Date of mailing of the international search report 10-JUN 2004
---	---

Name and mailing address of the ISA/US Commissioner of Patents and Trademarks Box PCT Washington, D.C. 20231 Facsimile No. (703)305-3230	Authorized officer Vishal Patel <i>V. Hoodger</i> Telephone No. 703-308-8495
--	--