



US 20030116872A1

(19) **United States**

(12) **Patent Application Publication**

Klemm et al.

(10) **Pub. No.: US 2003/0116872 A1**

(43) **Pub. Date: Jun. 26, 2003**

(54) **METHOD FOR TRANSFERRING FROM A MOLD A HYDROPHOBIC TOP COAT ONTO AN OPTICAL SUBSTRATE**

Related U.S. Application Data

(60) Provisional application No. 60/294,425, filed on May 29, 2001.

(75) Inventors: **Karl A. Klemm**, Largo, FL (US); **Julie A. Fairbank**, Pinellas Park, FL (US)

Publication Classification

Correspondence Address:
Mark B. Wilson
Fulbright & Jaworski L.L.P.
Suite 2400
600 Congress Avenue
Austin, TX 78701 (US)

(51) **Int. Cl.⁷ B29D 11/00**
(52) **U.S. Cl. 264/1.31; 264/1.32; 264/1.7; 264/1.9**

(73) Assignee: **Essilor International Compagnie Generale d'Optique**, Charenton cedex (FR)

(57) **ABSTRACT**

(21) Appl. No.: **10/156,918**

The invention relates to a method for forming from a mold optical articles. These methods are particularly useful in forming ophthalmic articles such as ophthalmic lenses, having a hydrophobic top coat thereon. Ophthalmic articles produced by these methods are also part of the invention.

(22) Filed: **May 29, 2002**

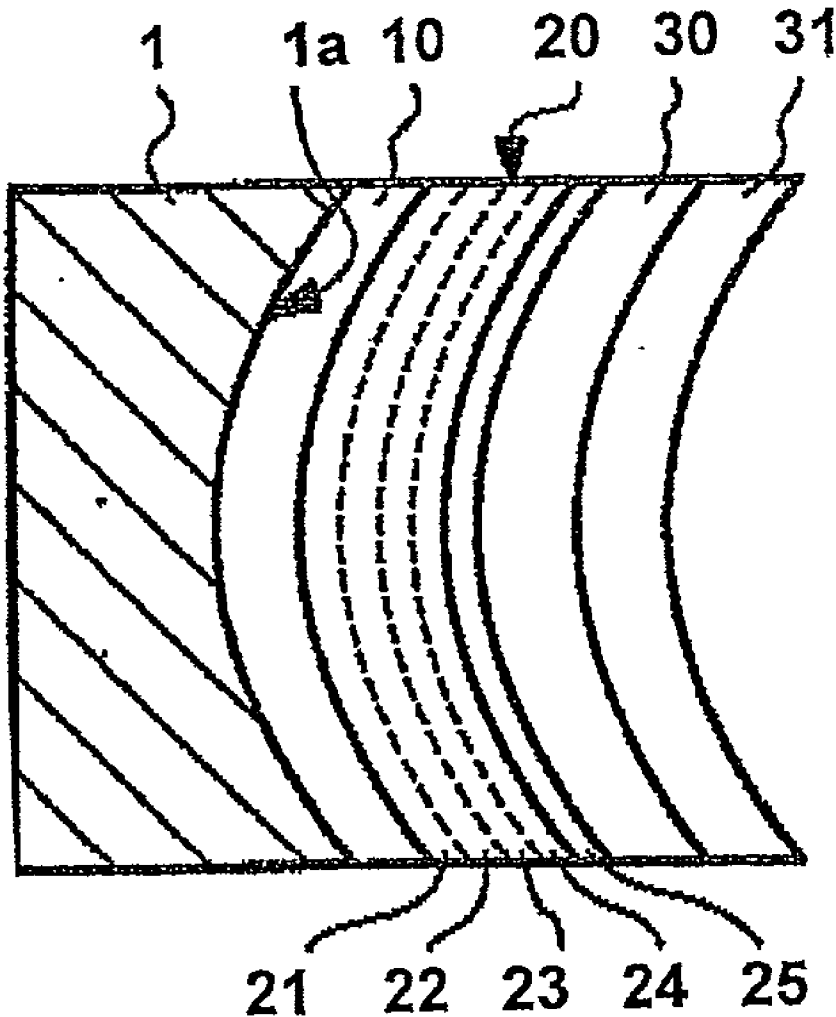

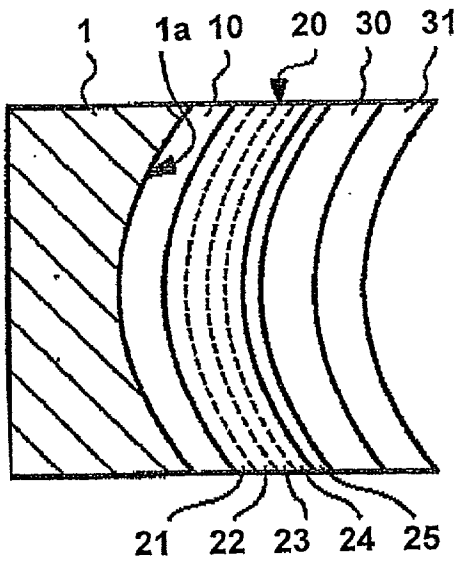

FIG. 1A

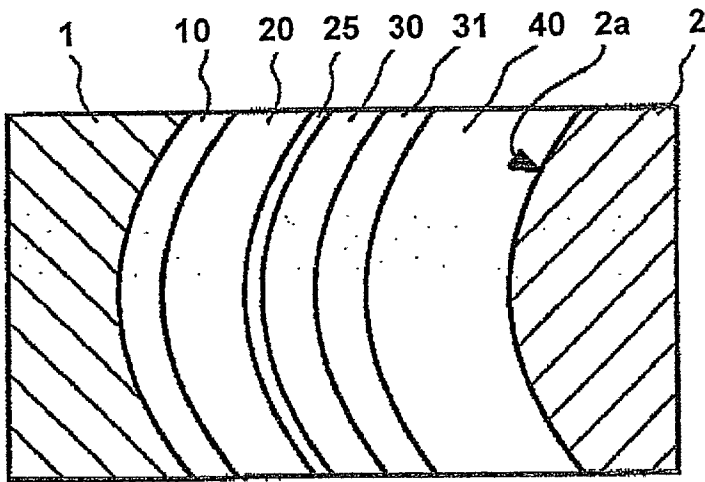

FIG. 1B

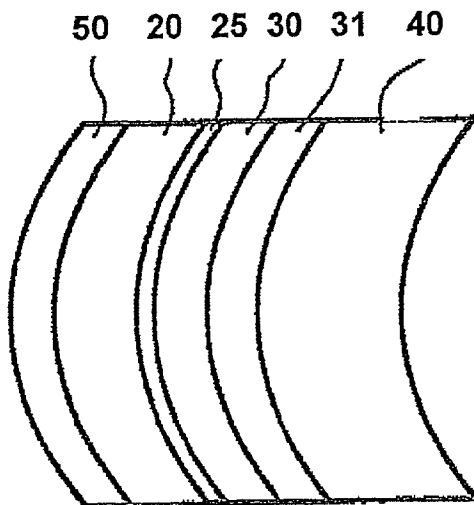

FIG. 1C

METHOD FOR TRANSFERRING FROM A MOLD A HYDROPHOBIC TOP COAT ONTO AN OPTICAL SUBSTRATE

CROSS-REFERENCE TO RELATED APPLICATIONS

[0001] This application claims priority to U.S. Provisional Application Serial No. 60/294,425 filed May 29, 2001.

BACKGROUND OF THE INVENTION

[0002] 1. Field of the Invention

[0003] The present invention relates to a method for forming from a mold optical articles, in particular ophthalmic articles such as ophthalmic lenses, having a hydrophobic top coat thereon.

[0004] 2. Previous Art

[0005] It is a common practice in the art to coat at least one face of an ophthalmic lens with several coatings for imparting to the finished lens additional or improved optical or mechanical properties. Thus, it is usual practice to coat at least one face of an ophthalmic lens substrate typically made of an organic glass material with successively, starting from the face of the substrate, an impact-resistant coating (impact-resistant primer), a scratch-resistant coating (hard coat), an anti-reflecting coating and a hydrophobic top coat.

[0006] Typically, optical articles made of organic glass materials are formed in a mold comprising two separate parts having optical surfaces which, when the two-parts are assembled, define a molding cavity. A liquid curable composition is then introduced in the molding cavity and cured to form the optical article. The optical article is thereafter recovered upon disassembling of the mold parts.

[0007] Examples of typical two-part molds and molding methods are disclosed in U.S. Pat. No. 5,547,618 and 5,662,839.

[0008] It is known in the art to also apply a scratch-resistant coating composition on the optical surfaces of the parts of a two-part mold, and if necessary precure it, assemble the mold parts, fill the molding cavity with an optical liquid curable material, cure the optical material and disassemble the mold parts to recover the molded optical article having a scratch-resistant coating deposited and adhered thereon.

[0009] Such a method is, for example, disclosed in document EP-102847.

[0010] U.S. Pat. No. 5,096,626 discloses a method for making an optical article having a scratch-resistant coating and/or an anti-reflecting coating thereon, which comprises:

[0011] forming an anti-reflecting coating and/or a scratch-resistant coating onto the optical surfaces of a two-part mold;

[0012] assembling the two-part mold;

[0013] pouring an optical liquid curable composition in the molding cavity;

[0014] curing the optical composition, and

[0015] disassembling the two-part mold for recovering the molded optical article having a scratch-

resistant coating or a scratch-resistant coating and an anti-reflecting coating thereon;

[0016] wherein, either at least one release agent is incorporated into the scratch-resistant coating or a film of at least one release agent is formed on the optical surfaces of the mold parts, prior to the formation of the anti-reflecting coating and/or the scratch-resistant coating.

[0017] The preferred release agents useful in the method of U.S. Pat. No. 5,096,626 are fluorosilicones, fluoroalkoxyalkoxysilanes and mixtures thereof.

[0018] U.S. Pat. No. 5,160,668 discloses a method for transferring an anti-reflecting coating onto a surface of an optical element which comprises:

[0019] forming on the optical surface of a part of a two-part mold a release layer of a water soluble inorganic salt;

[0020] forming on said release layer an anti-reflecting layer,

[0021] assembling the mold parts;

[0022] pouring a liquid optical curable composition in the molding cavity,

[0023] curing the optical composition,

[0024] disassembling the mold parts and dissolving the release layer in water to recover the coated optical element.

[0025] U.S. Pat. No. 5,733,483 discloses a method for forming on-site tinted and coated optical elements from a mold which comprises:

[0026] forming successively on an optical surface of at least one part of a two-part mold, a polymer release layer, an anti-reflecting coating layer, a coupling agent layer and a hard coat layer;

[0027] assembling the two-part mold;

[0028] pouring an optical liquid curable material in the molding cavity;

[0029] curing the optical material and the anti-reflecting, coupling agent and hard coat layers; and

[0030] disassembling the mold parts to recover the coated optical element.

[0031] The polymer release layer can be made of a water soluble polymer such as polyvinyl alcohol (PVA), polyethylene-oxide (PEO), poly(N-vinylpyrrolidone) (PNVP), polyvinylalcohol (PVA) or polyacrylamid (PAM); a non-water soluble and UV curable polymer such as polybutadiene-diacrylate (PBD-SA), polyethyleneglycol-diacrylate (PEG-DA) or a highly crosslinked acrylate, and commercial mold release agents such as Dow-Corning 20 Release.

[0032] The coupling agent layer generally comprises a (meth)acryloxyalkyltrialkoxysilane. This coupling agent layer is used in order to better extract the anti-reflecting coating from the mold.

[0033] Hydrophobic top coats are classically used for improving dirty mark resistance of finished optical articles, in particular optical articles comprising an anti-reflecting coating.

[0034] A problem associated with these hydrophobic top coats is their tendency to poorly adhere on the optical substrate and in particular on the anti-reflecting coating of a coated optical substrate.

[0035] What is needed is a method which will provide easy transfer from a mold of a hydrophobic top coat onto an optical substrate, in particular onto the anti-reflecting coating of a coated optical substrate as well as an improved adhesion of the hydrophobic top coat onto the optical substrate and in particular onto the anti-reflecting coating of a coated optical substrate.

SUMMARY OF THE INVENTION

[0036] It is an object of this invention to provide a method for easily transferring a hydrophobic top coat from a mold onto an optical substrate.

[0037] It is an additional object of this invention to provide a method for easily transferring a hydrophobic top coat from a mold onto the anti-reflecting coating of a coated optical substrate.

[0038] It is a further object of this invention to provide a method as above which provides improved adhesion of the hydrophobic top coat onto an optical substrate and in particular onto an anti-reflecting coating of a coated optical substrate.

[0039] In accordance with the above objects and those that will be mentioned and will become apparent below, the method for transferring a hydrophobic top coat onto an optical substrate comprises:

[0040] providing a two-part plastic mold having opposed optical surfaces defining therebetween a molding cavity;

[0041] forming on at least one of the optical surfaces of the mold, a hydrophobic top coat;

[0042] filling the molding cavity with an optical substrate liquid curable composition;

[0043] curing the liquid curable composition, and

[0044] disassembling the two-part mold for recovering an optical article comprising an optical substrate having deposited and adhered on at least one of its faces, a hydrophobic top coat.

[0045] In a preferred embodiment, the plastic mold is made of polycarbonate or polynorbornene.

[0046] To further improve release of the coated optical article from the mold, a release agent can be incorporated in the plastic material of the mold, or the optical surfaces of the mold parts can be coated with a release agent layer.

[0047] In a further preferred embodiment, the method according to the invention comprises, prior to filling the mold with the optical substrate composition, forming onto the hydrophobic top coat an anti-reflecting coating and optionally forming, in the indicated order, a scratch-resistant coating and/or an impact-resistant primer coating.

[0048] The anti-reflecting coating is typically comprised of a multilayer stack of alternating high and low refractive indices dielectric materials, generally a mineral oxide, which are preferably vacuum deposited.

[0049] In the most preferred embodiment, the uppermost layer of the stack (which is the first layer of the anti-reflecting stack directly deposited onto the hydrophobic top coat) is vacuum deposited using a two stage process.

[0050] In a first stage, a first thin sub-layer is deposited by vacuum evaporation of the appropriate dielectric material, directly on the hydrophobic top coat. In a second stage a second thin sub-layer of the same dielectric material is deposited on the first sub-layer using an ion assisted vacuum deposition process. Preferably, the dielectric material of the first layer is SiO₂.

BRIEF DESCRIPTION OF THE DRAWING

[0051] For the further understanding of the objects and advantages of the present invention, reference should be made to the following detailed description, taken in conjunction with the accompanying drawings, in which like parts are given like reference numerals and wherein:

[0052] **FIG. 1A** to **FIG. 1C** schematically illustrate the main steps of an embodiment of the method of the invention.

DETAILED DESCRIPTION OF THE INVENTION

[0053] Although in the following description, only one face of the optical article is being coated with the optical functional coatings according to the invention, it should be understood that both faces of the optical articles can be coated simultaneously using the method of the invention.

[0054] With respect to **FIG. 1A**, there is shown schematically a front part **1** of a two-part mold, on the optical surface **1a** of which has been successively formed a hydrophobic top coat **10**, an anti-reflecting coating **20**, a scratch-resistant coating **30** and an impact-resistant primer coating **31**.

[0055] The two-part mold used in the method of the invention comprises a front part **1** having an optical surface **1a** and a rear part **2** (**FIG. 1B**) having an optical surface **2a**.

[0056] Typically the two-parts **1, 2** of the mold are assembled through a gasket or an adhesive tape (not shown) so that the optical surfaces **1a, 2a** of the mold parts define therebetween a molding cavity.

[0057] The mold parts **1, 2** are preferably made of a plastic material.

[0058] Among the plastic materials that can be used for the two-part mold there can be cited: polycarbonates (PC), polyamides (PA), polyimides (PI), polysulfones (PS), copolymers of polyethyleneterephthalate and polycarbonate (PET-CP), crystal polyethyleneterephthalate (crystal PET), glass fiber reinforced polyethyleneterephthalate, and polyolefins such as polynorbornenes. The preferred plastic materials are polycarbonates and polynorbornenes.

[0059] A very good plastic material that can be used for the two part mold is a copolymer having the followings units

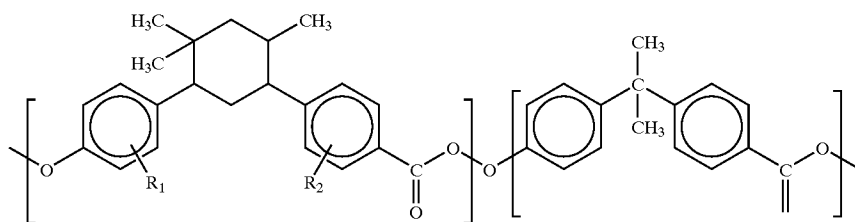

[0060] Such copolymer is available from Bayer under the commercial trade name APEC.

[0061] This copolymer has a high rigidity which can be an advantage for the use as a mold material.

[0062] Preferably, the thickness center for each mold part is at least 4 mm.

[0063] To enhance the release effect of the molds, in particular with regard to the hydrophobic top coating, one or more release agents can be incorporated in the polymer material of the mold. Examples of such release agents are trimethylchlorosilane, chloromethyltrimethylsilane, chloropropyltrimethylsilane, chloromethyldodecyl dimethylsilane, chlorine terminated polydimethyl siloxane, (3,3-dimethylbutyl) dimethylchlorosilane, hexamethyldisilazane, octamethyltetrasilazane, aminopropyl dimethyl terminated polydimethylsiloxane, 3-trimethoxysilyl propyloctadecyldimethylammonium chloride, tetradecyldimethyl (3-trimethoxysilylpropyl) ammonium chloride, trimethylethoxysilane and octadecyltrimethoxysilane.

[0064] If necessary the optical surfaces *1a*, *2a* of the parts of the plastic mold may be previously coated with a protective and/or release coating which either protects the optical surfaces from defects such as scratches that may be created during handling. This protective and/or release coating may also even the optical surface and/or enhance the release effect.

[0065] Examples of such coatings are:

[0066] A UV-curable acrylic layer optionally containing at least one of the above cited release agent or an amine containing polysiloxane layer optionally containing at least one of the above release agent;

[0067] A fluorocarbon polymer layer, such as polytetrafluoroethylene (PTFE) polymers, for example Teflon® AF, Teflon® PTFE FEP and Teflon® PTFE PFA;

[0068] A buffer layer which may delaminate from the mold part optical surface and from which the top coat can release, such as a vacuum-deposited magnesium fluoride (MgF₂) layer or a siloxane base coating normally used to input scratch resistance to lenses. Both of these layers release readily from the optical surface of the mold, in particular of a polycarbonate mold. After demolding of the optical article, these layers are eliminated.

[0069] The protective and/or release coatings can be deposited by dip coating or spin coating, and depending upon their technical natures they may be UV and/or ther-

mally cured or simply dried. Those protective and/or release coatings have typically a thickness of 2 nm to 10 μm.

[0070] The mold parts made of plastic material are UV transparent and allow UV and/or thermal curing of the different layers and in particular of the optical substrate composition. Preferably, the polymer material of the mold parts are free of UV absorber.

[0071] As shown in FIG. 1A, there is first deposited on the optical surface *1a* of the first part **1** of, for example, a polycarbonate mold, a hydrophobic top coat composition.

[0072] The hydrophobic top coat **10**, which in the finished optical article constitutes the outermost coating on the optical substrate, is intended for improving dirty mark resistance of the finished optical article and in particular of the anti-reflecting coating.

[0073] As known is the art, a hydrophobic top coat is a layer wherein the stationary contact angle to deionized water is at least 60°, preferably at least 75° and more preferably at least 90°. The stationary contact angle is determined according to the liquid drop method in which a water drop having a diameter smaller than 2 mm is formed on the optical article and the contact angle is measured.

[0074] The hydrophobic top coats preferably used in this invention are those which have a surface energy of less than 14 m Joules/m².

[0075] The invention has a particular interest when using hydrophobic top coats having a surface energy of less than 13 m Joules/m² and even better less than 12 m Joules/m².

[0076] The surface energy values referred just above are calculated according to Owens Wendt method described in the following document : "Estimation of the surface force energy of polymers" Owens D. K. Wendt R. G. (1969) J. Appl. Polym. Sci., 1741-1747.

[0077] Such hydrophobic top coats are well known in the art and are usually made of fluorosilicones or fluorosilazanes i.e. silicones or silazanes bearing fluor containing groups. Example of a preferred hydrophobic top coat material is the product commercialized by Shin Etsu under the name KP 801M.

[0078] The top coat **10** may be deposited onto the optical surface *1a* of mold part **1** using any typical deposition process, but preferably using thermal evaporation technique.

[0079] Thickness of the hydrophobic top coat **10** usually ranges from 1 to 30 nm, preferably 1 to 15 nm.

[0080] Anti-reflecting coatings and their methods of making are well known in the art. The anti-reflecting can be any

layer or stack of layers which improves the anti-reflective properties of the finished optical article.

[0081] The anti-reflecting coating may preferably consist of a mono- or multilayer film of dielectric materials such as SiO₂, SiO₂ Si₃N₄, TiO₂, ZrO₂, Al₂O₃, MgF₂ or Ta₂O₅, or mixtures thereof.

[0082] The anti-reflecting coating can be applied in particular by vacuum deposition according to one of the following techniques:

[0083] 1)—by evaporation, optionally ion beam-assisted;

[0084] 2)—by spraying using an ion beam,

[0085] 3)—by cathode sputtering; or

[0086] 4)—by plasma-assisted vapor-phase chemical deposition.

[0087] In case where the film includes a single layer, its optical thickness must be equal to $\lambda/4$ where λ is wavelength of 450 to 650 nm.

[0088] Preferably, the anti-reflecting coating is a multilayer film comprising three or more dielectric material layers of alternatively high and low refractive indexes.

[0089] Of course, the dielectric layers of the multilayer anti-reflecting coating are deposited on the hydrophobic top coat in the reverse order they should be present on the finished optical article.

[0090] In the embodiment shown in FIG. 1A, the anti-reflecting coating 20 comprises a stack of four layers formed by vacuum deposition, for example a first SiO₂ layer 21 having an optical thickness of about 100 to 160 nm, a second ZrO₂ layer 22 having an optical thickness of about 120 to 190 nm, a third SiO₂ layer 23 having an optical thickness of about 20 to 40 nm and a fourth ZrO₂ layer 24 having an optical thickness of about 35 to 75 nm.

[0091] In order to improve adhesion of the anti-reflecting coating 20 onto the hydrophobic top coat 10 and release of the hydrophobic top coat 10 from the optical surface 1a of mold part 1, the SiO₂ layer 21 of the anti-reflecting coating is deposited on the top coat 10 using a two-stage process.

[0092] In a first stage a first thin sub-layer of SiO₂ is deposited by vacuum evaporation, directly on the hydrophobic material of the top coat. In a second stage a second thin sub-layer of SiO₂ is deposited on the first sub-layer using an ion assisted vacuum deposition process.

[0093] The physical thickness of the final SiO₂ layer 21 ranges from 80 to 120 nm (optical thickness 100 to 160 nm).

[0094] Using the above two stage process as proved to result in good adhesion between the top coat and the anti-reflecting coating.

[0095] Preferably, after deposition of the four-layer anti-reflecting stack, a thin layer of SiO₂ 25 of 1 to 50 nm thick, is deposited. This layer 25 promotes the adhesion between the anti-reflecting stack and the scratch-resistant coating 30 to be subsequently deposited.

[0096] The next layer to be deposited is the scratch-resistant coating 30. Any known optical scratch-resistant coating composition can be used to form the scratch-resis-

tant coating 30. Thus, the scratch-resistant coating composition can be a UV and/or a thermal curable composition.

[0097] By definition, a scratch-resistant coating is a coating which improves the abrasion resistance of the finished optical article as compared to a same optical article but without the scratch-resistant coating.

[0098] Preferred scratch-resistant coatings are those made by curing a precursor composition including epoxyalkoxysilanes or a hydrolyzate thereof, silica and a curing catalyst. Examples of such compositions are disclosed in U.S. Pat. No. 4,211,823, WO 94/10230, U.S. Pat. No. 5,015,523.

[0099] The most preferred scratch-resistant coating compositions are those comprising as the main constituents an epoxyalkoxysilane such as, for example, γ -glycidoxypropyltrimethoxysilane (GLYMO) and a dialkyldialkoxysilane such as, for example dimethyldiethoxysilane (DMDES), colloidal silica and a catalytic amount of a curing catalyst such as aluminum acetylacetonate or a hydrolyzate thereof, the remaining of the composition being essentially comprised of solvents typically used for formulating these compositions.

[0100] In order to improve the adhesion of the scratch-resistant coating 30 to the impact-resistant primer coating 31 to be subsequently deposited, an effective amount of at least one coupling agent can be added to the scratch-resistant coating composition.

[0101] The preferred coupling agent is a pre-condensed solution of an epoxyalkoxysilane and an unsaturated alkoxysilane, preferably comprising a terminal ethylenic double bond.

[0102] Examples of epoxyalkoxysilanes are γ -glycidoxypropyltrimethoxysilane, γ -glycidoxypropylpentamethyldisiloxane, γ -glycidoxypropylmethyldiisopropenoxysilane, (γ -glycidoxypropyl)methyldiethoxysilane, γ -glycidoxypropyldimethylethoxysilane, γ -glycidoxypropyl-diisopropylethoxysilane and (γ -glycidoxypropyl)bis(trimethylsiloxy)methylsilane.

[0103] The preferred epoxyalkoxysilane is (γ -glycidoxypropyl) trimethoxysilane.

[0104] The unsaturated alkoxysilane can be a vinylsilane, an allylsilane, an acrylic silane or a methacrylic silane.

[0105] Examples of vinylsilanes are vinyltris(2-methoxyethoxy)silane, vinyltris(isobutoxy)silane, vinyltri-*t*-butoxysilane, vinyltriphenoxysilane, vinyltrimethoxysilane, vinyltriisopropoxysilane, vinyltriethoxysilane, vinyltriacetoxysilane, vinylmethyldiethoxysilane, vinylmethyldiacetoxy-silane, vinylbis(trimethylsiloxy)silane and vinyldimethoxyethoxysilane.

[0106] Examples of allylsilanes are allyltrimethoxysilane, alkyltriethoxysilane and allyltri(trimethylsiloxy)silane.

[0107] Examples of acrylic silanes are 3-acryloxypropyltri(trimethylsiloxy) silane, 3-acryloxypropyltrimethoxysilane, acryloxypropylmethyl-dimethoxysilane, 3-acryloxypropylmethylbis(trimethylsiloxy) silane, 3-acryloxypropyldimethylmethoxysilane, *n*-(3-acryloxy-2-hydroxypropyl)-3-aminopropyltriethoxysilane.

[0108] Examples of methacrylic silanes are 3-methacryloxypropyltri(trimethylsiloxy)silane, 3-methacry-

loxypropyltris (trimethylsiloxy) silane, 3-methacryloxypropyltris(methoxyethoxy)silane, 3-methacryloxypropyltrimethoxysilane, 3-methacryloxypropylpentamethyl disiloxane, 3-methacryloxypropylmethyl dimethoxysilane, 3-methacryloxypropylmethyl diethoxysilane, 3-methacryloxypropyl dimethyl methoxysilane, 3-methacryloxypropyl dimethyl ethoxysilane, 3-methacryloxypropenyltrimethoxysilane and 3-methacryloxypropylbis (trimethylsiloxy)methylsilane.

[0109] The preferred silane is acryloxypropyltrimethoxysilane. Preferably, the amounts of epoxyalkoxysilane(s) and unsaturated alkoxy silane(s) used for the coupling agent preparation are such that the weight ratio weight of epoxyalkoxysilane

$$R = \frac{\text{weight of epoxyalkoxysilane}}{\text{weight of unsaturated alkoxy silane}}$$

[0110] verifies the condition $0.8 \leq R \leq 1.2$.

[0111] The coupling agent preferably comprises at least 50% by weight of solid material from the epoxyalkoxysilane(s) and unsaturated alkoxy silane(s) and more preferably at least 60% by weight.

[0112] The coupling agent preferably comprises less than 40% by weight of liquid water and/or organic solvent, more preferably less than 35% by weight.

[0113] The expression "weight of solid material from epoxyalkoxy silanes and unsaturated alkoxy silanes" means the theoretical dry extract from those silanes which is the calculated weight of unit $Q_k \text{SiO}_{(4-k)/2}$ where Q is the organic group that bears the epoxy or unsaturated group and $Q_k \text{SiO}_{(4-k)/2}$ comes from $Q_k \text{Si R}'\text{O}_{(4-k)}$ where SiR' reacts to form SiOH on hydrolysis.

[0114] k is an integer from 1 to 3 and is preferably equal to 1.

[0115] R' is preferably an alkoxy group such as OCH_3 .

[0116] The water and organic solvents referred to above come from those which have been initially added in the coupling agent composition and the water and alcohol resulting from the hydrolysis and condensation of the alkoxy silanes present in the coupling agent composition.

[0117] Preferred preparation methods for the coupling agent comprises:

[0118] 1) mixing the alkoxy silanes

[0119] 2) hydrolysing the alkoxy silanes, preferably by addition of an acid, such as hydrochloric acid

[0120] 3) stirring the mixture

[0121] 4) optionally adding an organic solvent

[0122] 5) adding one or several catalyst(s) such as aluminum acetylacetonate

[0123] 6) stirring (typical duration: overnight).

[0124] Typically the amount of coupling agent introduced in the scratch-resistant coating composition represents 0.1 to 15% by weight of the total composition weight, preferably 1 to 10% by weight.

[0125] The scratch-resistant coating composition can be applied on the anti-reflecting coating using any classical method such as spin, dip or flow coating.

[0126] The scratch-resistant coating composition can be simply dried or optionally precured before application of the subsequent impact-resistant primer coating 31. Depending upon the nature of the scratch-resistant coating composition thermal curing, UV-curing or a combination of both can be used.

[0127] Thickness of the scratch-resistant coating 30, after curing, usually ranges from 1 to 15 μm , preferably from 2 to 6 μm .

[0128] Before applying the impact resistant primer on the scratch resistant coating, it is possible to subject the surface of the scratch resistant coating to a corona treatment or a vacuum plasma treatment, in order to increase adhesion.

[0129] The impact-resistant primer coating 31 can be any coating typically used for improving impact resistance of a finished optical article. Also, this coating generally enhances adhesion of the scratch-resistant coating 30 on the substrate of the finished optical article.

[0130] By definition, an impact-resistant primer coating is a coating which improves the impact resistance of the finished optical article as compared with the same optical article but without the impact-resistant primer coating.

[0131] Typical impact-resistance primer coatings are (meth)acrylic based coatings and polyurethane based coatings.

[0132] (Meth)acrylic based impact-resistant coatings are, among others, disclosed in U.S. Pat. No. 5,015,523 whereas thermoplastic and crosslinked based polyurethane resin coatings are disclosed inter alia, in Japanese Patents 63-141001 and 63-87223, EP-0404111 and U.S. Pat. No. 5,316,791.

[0133] In particular, the impact-resistant primer coating according to the invention can be made from a latex composition such as a poly(meth)acrylic latex, a polyurethane latex or a polyester latex.

[0134] Among the preferred (meth)acrylic based impact-resistant primer coating compositions there can be cited polyethyleneglycol(meth)acrylate based compositions such as, for example, tetraethyleneglycoldiacrylate, polyethyleneglycol (200) diacrylate, polyethyleneglycol (400) diacrylate, polyethyleneglycol (600) di(meth)acrylate, as well as urethane (meth)acrylates and mixtures thereof.

[0135] Preferably the impact-resistant primer coating has a glass transition temperature (T_g) of less than 30° C.

[0136] Among the preferred impact-resistant primer coating compositions, there may be cited the acrylic latex commercialized under the name Acrylic latex A-639 commercialized by Zeneca and polyurethane latex commercialized under the names W-240 and W-234 by Baxenden.

[0137] In a preferred embodiment, the impact-resistant primer coating may also include an effective amount of a

coupling agent in order to promote adhesion of the primer coating to the optical substrate and/or to the scratch-resistant coating.

[0138] The same coupling agents, in the same amounts, as for the scratch-resistant coating compositions can be used with the impact-resistant coating compositions.

[0139] The impact-resistant primer coating composition can be applied on the scratch-resistant coating **30** using any classical method such as spin, dip, or flow coating.

[0140] The impact-resistant primer coating composition can be simply dried or optionally precured before molding of the optical substrate. Depending upon the nature of the impact-resistant primer coating composition, thermal curing, UV-curing or a combination of both can be used.

[0141] Thickness of the impact-resistant primer coating **31**, after curing, typically ranges from 0.05 to 20 μm , preferably 0.5 to 10 μm and more particularly from 0.6 to 6 μm .

[0142] The next step of the method is, as shown in FIG. 1B, assembling the front part 1 coated with the hydrophobic top coat, the anti-reflecting, scratch-resistant and impact-resistant primer coatings **20, 30, 31** with the rear part 2 of the two-part mold as described, for example, in U.S. Pat. Nos. 5,547,618 and 5,562,839.

[0143] The molding cavity is then filled with a liquid curable optical composition which is cured to form the optical substrate **40**.

[0144] The optical substrate can be made from any typical liquid, curable composition used in the optical field.

[0145] Examples of such optical substrates are substrates resulting from the polymerization of:

[0146] diethylene glycol bis (allylcarbonate) based compositions,

[0147] (meth)acrylic monomer based compositions, such as compositions comprising (meth)acrylic monomers derived from bisphenol-A;

[0148] thio(meth)acrylic monomer based compositions;

[0149] polythiourethane precursor monomer based compositions; and

[0150] epoxy and/or episulfide monomer based compositions.

[0151] Depending upon the nature of the curable optical material, the optical material can be thermally cured, UV-cured or cured with a combination of both, or cured at ambient temperature.

[0152] As shown in FIG. 1C, once the optical substrate **40** has been cured, and optionally concurrently the scratch-resistant coating **30** and the impact-resistant primer coating **31** if not previously cured, the mold part **10, 11** are disassembled to recover the optical substrate **40** having transferred on one face, the impact-resistant primer coating **31**, the scratch-resistant coating **30**, the anti-reflecting coating **20** and the hydrophobic top coat **10**.

[0153] The following examples illustrate the present invention. In the examples, unless otherwise stated, all parts and percentages are by weight.

[0154] 1. Two-Part Mold

[0155] In all the examples the mold used was made of polycarbonate (General Electric Company).

[0156] 2. Hydrophobic Top Coat

[0157] Hydrophobic top coat used in the examples is a fluorosilazane commercialized by SHIN ETSU under the name KP 801M.

[0158] 3. Scratch-Resistant Coating Compositions (Hard Coating Composition)

[0159] The following thermal and/or UV curable hard coating compositions were prepared by mixing the components as indicated hereinunder.

Component	Parts by weight
<u>Hard coating composition n° 1: thermally curable</u>	
Glymo	21.42
0.1N HCl	4.89
Colloidal Silica 1034A (35% solid)	30.50
Methanol	29.90
Diacetone alcohol	3.24
Aluminum acetylacetonate	0.45
Coupling agent	9.00
Surfactant (1/10 dilution)	0.60
<u>Hard coating composition n° 2: thermally curable</u>	
Glymo	18.6
0.1N HCl	6.62
Dimethyldiethoxysilane (DMDES)	9.73
Colloidal Silica/MeOH ⁽¹⁾	60.1
Aluminum acetylacetonate	1.2
Methyl Ethyl Ketone (MEK)	3.65
Coupling agent	5.00
Surfactant FC 430 ⁽²⁾	0.05
<u>Hard coating composition n° 3: thermally curable</u>	
Glymo	18.6
0.1N HCl	6.62
Dimethyldiethoxysilane	9.73
Colloidal Silica/MeOH ⁽¹⁾	60.1
Aluminum acetylacetonate	1.2
Methyl Ethyl Ketone (MEK)	3.65
Surfactant FC430 ⁽²⁾	0.05
<u>Hard coating composition n° 4: (UV curable)</u>	
Glymo	23.75
n-propanol	14.25
Colloidal Silica/MeOH ⁽¹⁾	47.51
Tyzor DC (1% dilution) ⁽³⁾	14.25
UVI-6974 ⁽⁴⁾	0.2735
<u>Coupling agent: precondensed solution of:</u>	
Glymo	10.0
Acryloxypropyltrimethoxysilane	10.0
0.1N HCl	0.5
Aluminum acetylacetonate	0.2
Diacetone alcohol	1.0

⁽¹⁾Sun Colloid MA-ST from NISSAN Company (containing 30% by weight of solid SiO₂)

⁽²⁾FC430: surfactant commercialized by 3M Company

⁽³⁾Tyazor:

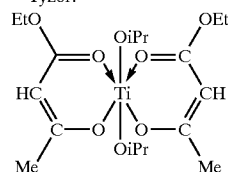

-continued

Component	Parts by weight
-----------	-----------------

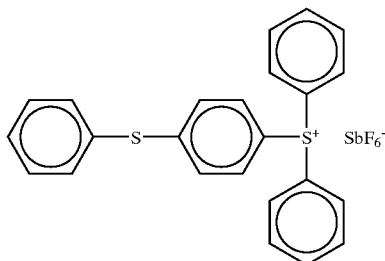
⁽⁴⁾UVI-6974 Mixture of:

and

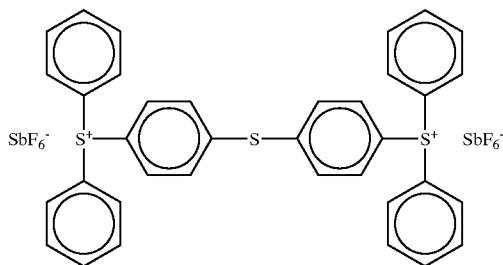

[0160] 4. Impact-Resistant Primer Coating Compositions (Primer Coating Compositions)

[0161] Several primer coating compositions were made by mixing the various components as indicated below:

Component	Parts by weight
<u>Impact Primer Coating Composition n° 1a (UV curable Acrylic)</u>	
Tetraethylene glycol diacrylate (SR-268)	12.42
Aliphatic urethane triacrylate (EB-265)	16.87
n-propanol	20.27
Dowanol PM ⁽⁵⁾	20.27
Dowanol PnP ⁽⁶⁾	20.27
Coupling agent	9.00
ITX ⁽⁷⁾	0.063
Irgacure 500 ⁽⁸⁾	0.60
Surfactant FC-430 (50% dilution)	0.21
<u>Impact Primer Coating Composition n° 1b (UV curable Acrylic)</u>	
Polyethylene (400) glycol diacrylate (SR-344)	12.42
Aliphatic urethane triacrylate (EB-265)	16.87
n-propanol	20.27
Dowanol PM	20.27
Dowanol PnP	20.27
Coupling agent	9.00
ITX	0.063
Irgacure 500	0.60
Surfactant FC-430 (50% dilution)	0.21
<u>Impact Primer Coating Composition n° 2 (thermal curable polyurethane latex W-234)</u>	
Polyurethane Latex W-234 ⁽⁹⁾	35.0
Deionized Water	50.0
2-Butoxy Ethanol	15.0
Coupling agent	5.0

-continued

Component	Parts by weight
-----------	-----------------

or

Polyurethane Latex W 234	40.0
Deionized Water	40.0
Dowanol PnP	20.0
Coupling agent	5.0
Surfactant L77 ⁽¹⁰⁾	0.5

Impact Primer Coating Composition n° 3 (Thermal curable, Acrylic latex A-639)

Acrylic latex A-639 ⁽¹¹⁾	40.0
Deionized water	40.0
2-Butoxy Ethanol	20.0

Impact Primer Coating Composition n° 4 (UV curable Hybrid)

UVR6110 ⁽¹²⁾	13.00
HDODA ⁽¹³⁾	10.89
Pentaerithritol pentaacrylate	30.36
GE 21 ⁽¹⁴⁾	30.29
Diethylene glycol diacrylate	7.01
Isobornyl acrylate	2.29
Surfactant	0.09
Mixed triarylsulfonium	0.30

hexafluoroantimonate salts

Impact Primer Coating Composition n° 5 (UV curable Hybrid)

UVR6110	13.00
HDODA	10.89
Polyethylene glycol (400) diacrylate	30.36
GE 21	30.29
Diethylene glycol diacrylate	7.01
Isobornyl acrylate	2.29
Surfactant	0.09
Mixed triarylsulfonium	0.30

hexafluoroantimonate salts

⁽⁵⁾ Dowanol PM: 1-methoxy-2-propanol and 2-methoxy-1-propanol solvent commercialized by DOW CHEMICAL.

⁽⁶⁾ Dowanol PnP: solvent commercialized by DOW CHEMICAL which is a mixture of:

1-propoxy-2-propanol, 2-propoxy-1-propanol, Propyleneglycol, Diethyleneglycol, Dipropylglycolmonopropylether

⁽⁷⁾ ITX: Isopropylthioxanthone

⁽⁸⁾ Irgacure 500: 1/1 mixture of benzophenone + 1-hydroxycyclohexylphenyl

⁽⁹⁾ Polyurethane latex commercialized by Baxenden

⁽¹⁰⁾ L77 surfactant commercialized by OSI Specialities

⁽¹¹⁾ Acrylic Latex-A-639 commercialized by Zeneca

⁽¹²⁾ UVR6110: 3,4-epoxycyclohexylmethyl-3,4-epoxycyclohexyl carboxylate + monoepoxyde of 3-cyclohexenylmethyl-3-cyclohexylcarboxylate

⁽¹³⁾ HDODA: 1,6-hexanediol diacrylate

⁽¹⁴⁾ GE21: 1,4-butanediol diglycidyl ether

[0162] 5. Optical Substrate Compositions

The following mixture was prepared at 40° C. in the dark.

Component	Parts by weight
<u>Optical substrate composition n° 1 (UV/Thermally curable)</u>	
Tetraethoxy bisphenol A dimethacrylate	980
Methyl butene-1 ol	20
Irgacure 1850 ⁽¹⁵⁾	1.75
<u>Optical substrate composition n° 2 (UV/Thermally curable)</u>	
Polypropyleneglycol (400) dimethacrylate	51
Urethane methacrylate (Plex ® 66610)	34
Isobornyle methacrylate	15
Irgacure 1850 ⁽¹⁵⁾	0.1
<u>Optical substrate composition n° 3 (UV/Thermally curable)</u>	
Thiomethacrylate ⁽¹⁶⁾	70
Dicyclopentadiene dimethacrylate	10
FA321M ⁽¹⁷⁾	20
Methylbutene-1 ol	0.3
UV 5411 ⁽¹⁸⁾	0.1
Irgacure 819 ⁽¹⁹⁾	0.1

⁽¹⁵⁾Irgacure 1850: mixture (50/50 by weight) of:

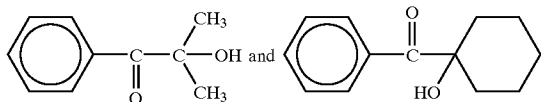

⁽¹⁶⁾Thiomethacrylate: Plex 6856 sold by RÖHM.

⁽¹⁷⁾FA 321M:

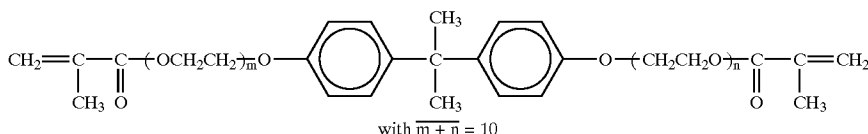

⁽¹⁸⁾UV 5411: 2-(2-hydroxy-5-t-octylphenyl)benzotriazole.

⁽¹⁹⁾Irgacure 819: photoinitiator of formula:

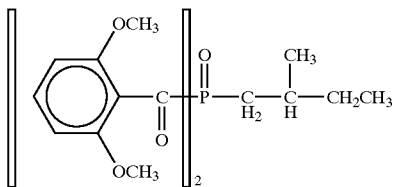
**[0163]** 6. Preparation of the Mold

[0164] Unless otherwise stated, the polycarbonate molds used in the examples were prepared as follows:

[0165] a) The injection-molded polycarbonate mold is de-gated and then edged. The edging process may create scratches on the surface of the mold, so tape covering of at least the central portion of the mold surface is used during edging.

[0166] b) After edging, the mold is wiped, cleaned in ultrasonic system, and then heated in a clean oven for half an hour at 100° C.

[0167] 7. Deposition of Hydrophobic Top Coat and Anti-Reflecting Coating

[0168] Unless otherwise stated, hydrophobic top coat and anti-reflecting coating were deposited on the optical surface of the front part of the mold as follows:

[0169] The hydrophobic top coat and anti-reflecting treatments are accomplished in a standard box coater using well known vacuum evaporation practices.

[0170] a—The mold is loaded into the standard box coater such as a Balzers BAK760 and the chamber is pumped to a high vacuum level.

[0171] b—Hydrophobic top coat, fluorosilazane (Shin Etsu KP801M), is deposited onto the optical surface of the first part of the mold using a thermal evaporation technique, to a thickness in the range of 2-15 nm.

[0172] c—The dielectric multilayer anti-reflecting (AR) coating, consisting of a stack of high- and low-index materials is then deposited, in reverse of the normal order. Details of this deposition are as such:

[0173] c1—The first oxide layer in the antireflecting stack to be deposited is SiO₂. This SiO₂ layer is created in a two-stage process. In the first stage, 2-12 nm of SiO₂ is deposited, by vacuum evaporation, directly on the hydrophobic material with no extra energetic assistance during deposition. The SiO₂ deposition is then temporarily halted.

[0174] c2—After this first amount of SiO₂ has been deposited, the ion source is once again turned on, such that the surface of the SiO₂ is ion bombarded with energetic ions of argon gas, oxygen gas, or a mixture of the two gases.

[0175] c3—While the surfaces of the lenses are ion bombarded, deposition of SiO₂ is restarted. Because this second stage of SiO₂ deposition is accomplished concurrently with energetic ion bombardment from the ion source, the SiO₂ deposition is considered “ion-assisted”. This second stage of SiO₂ film growth deposits approximately of 68-98 nm of material. Thus, the total thickness the first of SiO₂ layer (created from these two stages of SiO₂ deposition) is 80-110 nm (optical thickness about 100 to 160 nm).

[0176] c4—After the first SiO₂ layer deposition sequence is accomplished, the remainder of the four-layer anti-reflecting coating is deposited, in reverse of the normal order, using standard vacuum evaporation deposition techniques, which normally, do not require ion assistance during deposition.

[0177] The second layer is a layer of ZrO₂ having an optical thickness of about 160 nm, the third layer is a SiO₂ layer having an optical thickness of about 30 nm and the fourth layer is a ZrO₂ layer having a thickness of about 55 nm (optical thicknesses are given at a wavelength of 550 nm).

[0178] d—At the completion of the deposition of the four-layer anti-reflecting stack, a thin layer of SiO₂, having a physical thickness of 1-50 nm, is deposited. This layer is to promote adhesion between the oxide anti-reflecting stack and the subsequent hard-coating which will be deposited on the coated mold at a later time.

EXAMPLE 1

[0179] The front part of a polycarbonate two-part mold already coated with a hydrophobic top coat and an AR coating was coated with Hard Coating Composition n° 1. Hard coating application speed was set at 400 rpm for 8 seconds and spin off speed at 800 rpm for 10 seconds. Hard

Coating Composition is cured by IR for 30 seconds with 725F setting, using Lesco IR curing unit. The coated mold was allowed to cool to room temperature and Impact Primer Coating Composition n° 1a is applied at the same speed and timing as mentioned above. Impact Primer Coating composition is cured by UV light, using Fusion system H bulb with belt speed of (5 feet per minute) 1.526 m/minute.

[0180] Final coating cure was achieved using Lesco IR curing unit set at 725F for 30 seconds.

[0181] The coated plastic mold was assembled, filled with optical substrate composition n° 1 and polymerized within 20 minutes. Upon disassembly of the plastic mold, all of the coatings were transferred to the finished lens.

EXAMPLE 2

[0182] The first part of a polycarbonate two-part mold already coated with a hydrophobic top coat and an AR coating was coated with Hard Coating Composition n° 1. Hard coating application speed was set at 400 rpm for 8 seconds and spin off speed at 800 rpm for 10 seconds. Hard Coating Composition cured by IR for 30 seconds with 725F setting, using Lesco IR curing unit. The coated mold was allowed to cool to room temperature and Impact Primer Coating Composition n° 1b was applied at the same speed and timing as mentioned above. Impact Primer Coating Composition was cured by UV light, using Fusion system H bulb with belt speed of (5 feet per minute) 1.524 m/minute.

[0183] Final coating cure was achieved using Lesco IR curing set at 725F for 30 seconds.

[0184] The coated plastic mold was assembled, filled with optical substrate Composition n° 1 and polymerized within 20 minutes. Upon disassembly of the plastic mold, all of the coatings were transferred to the finished lens.

EXAMPLE 3

[0185] The front part of a polycarbonate two-part mold already coated with a hydrophobic top coat and an AR coating was coated with Hard Coating Composition n° 2. Hard coating application speed was 500 rpm for 8 seconds and spin off at 1200 rpm for 10 seconds. Hard Coating Composition precured in a thermal heated oven for 10 minutes at 80° C. The coated mold was allowed to cool to room temperature. Impact Primer Coating Composition n° 2 was applied at the application speed 400 rpm for 8 seconds and spin off 1000 rpm for 10 seconds. Impact Primer Coating was precured at the same temperature and timing as the Hard Coating.

[0186] Final coating curing was done in a thermal heated oven for 1 hour at 90° C.

[0187] The coated plastic mold was assembled, filled with optical substrate composition n° 1 and polymerized within 20 minutes. Upon disassembly of the molds, all of the coatings transferred to the finished lens.

EXAMPLE 4

[0188] The front part of a polycarbonate two-part mold already coated with a hydrophobic top coat and an AR coating was coated with Hard Composition n° 3, this hard coating did not contain a coupling agent. Hard coating application speed was 500 rpm. for 8 seconds and spin off.

at 1200 rpm. for 10 seconds. Hard Coating was precured in a thermal heated oven for 10 minutes at 80° C. The coated mold was allowed to cool to room temperature. Impact Primer Coating Composition n° 2 was applied at the application speed ⁴⁰⁰ rpm for 8 seconds and spin off 1000 rpm for 10 seconds. Impact Primer Coating was precured at the same temperature and timing as the Hard Coating.

[0189] Final coating curing was done in a thermal heated oven for 1 hour at 90° C.

[0190] The coated plastic mold was assembled, filled with optical substrate composition n° 1 and polymerized within 20 minutes. Upon disassembly of the mold, all of the coatings transferred to the finished lens.

EXAMPLE 5

[0191] The front part of a polycarbonate two-part mold already coated with a hydrophobic coat and an AR coating was coated with Hard Coating Composition n° 2. Hard coating application speed was 500 rpm for 8 seconds and spin off at 1200 rpm. for 10 seconds. Hard Coating was precured in a thermal heated oven for 10 min at 80° C. Coated mold was cooled down to room temperature. Impact Primer Coating Composition 3 was applied at the application speed 600 rpm for 8 seconds and spin off 1500 rpm for 10 seconds. Impact Primer Coating was precured at the same temperature and timing as Hard Coating Composition n° 2.

[0192] Final coating curing was achieved in a thermal heated oven for 2 hours at 90° C.

[0193] The coated molds were assembled, filled with optical substrate composition n° 1 and polymerized within 20 minutes. Upon disassembly of the plastic mold, all of the coatings transferred to the finished lens.

EXAMPLE 6

[0194] The front part of a polycarbonate two-part mold already coated with a hydrophobic top coat and an AR coating was coated with Hard Coating Composition n° 4. Hard coating application speed was set at 600 rpm for 8

seconds and spin off speed at 1200 rpm for 10 seconds. Hard Coating was UV cured by Fusion system H bulb at (5 feet per minute) 1.524 m/minute and followed by 30 seconds IR cure at 725F for 30 seconds, using Lesco IR curing unit. Coated mold was allowed to cool to room temperature and impact Primer Coating Composition n° 4 was applied at the same speed and timing as mentioned above. Impact Primer Coating was cured by UV light, using Fusion system H bulb with belt speed of (5 feet per minute) 1.524 m/minute.

[0195] Final coating curing was achieved using Lesco IR curing unit set at 725F for 30 seconds.

[0196] The coated plastic mold was assembled, filled with optical composition n° 1 and polymerized within 20 minutes. Upon disassembly of the mold, all of the coatings transferred to the finished lens.

EXAMPLE 7

[0197] The front part of a polycarbonate two-part mold already coated with a hydrophobic top coat and an AR coating was coated with Hard Coating Composition n° 4. Hard coating application speed was set at 600 rpm for 8 seconds and spin off speed at 1200 rpm for 10 seconds. Hard Coating UV is cured by Fusion system H bulb at (5 feet per minute) 1.524 m/minute and followed by 30 seconds IR cure at 725F for 30 seconds, using Lesco IR curing unit. Coated mold was allowed to cool to room temperature and Impact Primer Coating n° 5 was applied at the same speed and timing as mentioned above. Impact Primer Coating was cured by UV light, using Fusion SYSTEM H bulb with belt speed of (5 feet per minute) 1.524 m/minute.

[0198] Final coating curing was achieved using Lesco IR curing unit set at 725F for 30 seconds.

[0199] The coated plastic mold was assembled, filed with optical substrate Composition n° 1 and polymerized within 20 minutes. Upon disassembly of the mold, all of the coating transferred to the finished lens.

[0200] The performances of the finished lenses of examples 1 to 7 A are given in Table below:

Example n°	Dry adhesion test	Bayer abrasion test	Steel wool test	Transmission (%)	Impact energy (mJ)
1	Well	4.47	1	98.8	692.40 Tc = 1.68 mm
2	Well	4.73	1	98.8	1126.60 Tc = 2.56 mm
3	Well	5.35	0	98.9	711.00 Tc = 1.38 mm
4	Well	4.37	0	98.9	844.00 Tc = 1.46 mm
5	Well	4.81	0	97.9	339.80 Tc = 1.48 mm
6	Well	4.22	0	98.8	62.40 Tc = 1.37 mm
7	Well	2.66	5	98.6	849.00 Tc = 1.34 mm

Tc = Thickness at center

EXAMPLE 8

[0201] This example illustrates the use of a protective and releasing coating on the optical surfaces of the mold.

[0202] The composition of the protective and releasing coating was as follows:

Component	Parts by weight
PETA LQ (acrylic ester of pentaerythritol)	5.00
Dowanol PnP	5.00
Dowanol PM	5.00
n-propanol	5.00
1360 (Silicone Hexa-acrylate, Radcure)	0.10
Coat-O-Sil 3503 (reactive flow additive)	0.06
Photoinitiator	0.20

[0203] The polycarbonate molds are cleaned using soap and water and dried with compressed air. The mold surface are then coated with the above protecting and releasing coating composition via spin coating with application speed of 600 rpm for 3 seconds and dry speed of 1200 rpm for 6 seconds. The coating was cured using Fusion Systems H+bulb at a rate of (5 feet per minute) 1.524 m/minute. A hydrophobic top coat and a reverse stack of vacuum deposited AR layers are then applied directly on the above coated molds according to the general procedure described previously. Once AR coating deposition was finished, the molds were coated first with a hard coating composition n° 1 and then with an impact primer coating composition n° 2, cured, and lenses were cast from optical substrate composition n° 1.

EXAMPLE 9

[0204] Example 8 is reproduced except that the mold releasing and protective coating composition was as follows:

Component	Parts by weight
PETA LQ (acrylic ester of pentaerythritol)	4.00
Dowanol PnP	5.00
Dowanol PM	5.00
n-propanol	5.00
1360 (Silicone Hexa-acrylate, Radcure)	2.00
Surface active agent	0.06
Photoinitiator	0.20

[0205] The whole stack top coat/AR coating/hard coat/primer released well from the coated polycarbonate mold and a lens having very good anti-abrasion, antireflective and impact properties was obtained.

EXAMPLE 10

[0206] Example 8 is reproduced except that the mold releasing and protective coating composition was as follows:

Component	Parts by weight
PETA LQ (acrylic ester of pentaerythritol)	5.00
Dowanol PnP	5.00
Dowanol PM	5.00
n-propanol	5.00
Coat-O-Sil 3509 (reactive flow additive)	0.10
Photoinitiator	0.20

[0207] The whole stack top coat/AR coating/hard coat/primer released well from the coated polycarbonate mold and a lens having very good anti-abrasion, antireflective and impact properties was obtained.

EXAMPLE 11

[0208] Example 8 is reproduced except that the molds are coated with the following release coating compositions according to the following protocols, before application of the subsequent coatings.

Mold coating composition A:	
Deionized water at 60° C.	0.95
A-1100 (gamma aminopropyl trimethoxy silane)	0.50
Mold coating composition B:	
Deionized Water at 60° C.	0.95
Dow Q9-6346 (3-trimethoxysilyl propyl octadecyl dimethylammonium chloride)	0.50

[0209] The polycarbonate molds were cleaned using soap and water and dried with compressed air. The molds surfaces were treated by dip coating in the mold coating composition A first for 60 seconds then rinsed off by 60° C. deionized water; then they were coated by dip with mold coating composition B and also rinsed off with deionized water at 60° C. The coating composition B was cured using Blue M convection oven at 80° C. for 15 min.

[0210] The whole stack top coat/AR coating/hard coat/primer released well from the coated polycarbonate mold and a lens having very good anti-abrasion, antireflective and impact properties was obtained.

EXAMPLE 12

[0211] Example 8 is reproduced except that the molds were coated with a fluorocarbon polymer layer as a releasing coating.

[0212] Polycarbonate molds were prepared by cleaning ultrasonically in warmed aqueous detergents, then rinsed and dried according to known art. The polycarbonate molds were then heated to 100° C. for a period of time from 0.1-3 hours, to fully dry the material.

[0213] The molds were then loaded in the vacuum chamber. The chamber is pumped to a vacuum level. Then, the

fluoropolymer Teflon was evaporated onto the mold surfaces using either resistance or electron beam heating, to a thickness of 2.5 to 150 nm.

[0214] Alternatively, the fluoropolymer layer was applied to the mold surfaces prior to vacuum deposition by means of spin- or dip-coating, using a dilute solution of soluble fluoropolymers such as Teflon AF, Teflon PTFE FEP, or Teflon PTFE PFA. The thickness of these coatings was 30 to 200 nm.

[0215] After deposition of the fluoropolymer layer, the hydrophobic top coat (KP 801M) and the oxide anti-reflecting multilayer stack were deposited (in reverse of the normal order), using the process described above.

[0216] KP801M hydrophobic material was evaporated on the fluoropolymer layer using resistance heating. SiO₂ layer, which is the top oxide layer of the AR stack, was then deposited in a two-stage process. The first stage was the deposition of 2-12 nm of SiO₂ without ion bombardment, and then the balance of the SiO₂ was deposited with argon ion bombardment, to a total SiO₂ thickness of approximately 85 nm. After the SiO₂ layer, the remaining layers of the stack was deposited by standard evaporative processes.

[0217] The layer vacuum deposited final was a thin SiO₂ layer after the stack is completed, to promote adhesion of the AR stack to the siloxane-based anti-scratch coating. This layer is not optically active, but is included only to enhance adhesion of the vacuum-deposited AR stack to the anti-scratch coating. Thereafter the other layers were deposited and the lenses cured according to the method described in example 8.

[0218] The whole stack top coat/AR coating/hard coat/primer released well from the Teflon coated polycarbonate mold and a lens having very good anti-abrasion, anti-reflecting and impact properties was obtained.

EXAMPLE 13

[0219] Example 3 is reproduced, but using optical substrate composition n° 2 instead of optical substrate composition n° 1, which is then cured as follows:

[0220] The mold parts are taped in order to produce a cavity and filled using a syringe, with the optical substrate composition n° 2.

[0221] A pre-cure was made in 15 s using a iron doped mercury UV bulb supplied by IST, the intensity was 25-30 mW/cm² (measured 420 nanometer with 0M 2 radiometer).

[0222] Curing was made in IST two side curing oven 2 minutes at 175 mW/cm².

[0223] Then curing was achieved in a thermal dynamic air oven, at a temperature of 80° C. for 8 minutes.

[0224] The assembly was edged with the plastic molds in order to generate a clear interface to help molds taking a part.

[0225] The complete stack was transferred to the lens.

EXAMPLE 14

[0226] Example 13 was reproduced, but using optical substrate composition n° 3.

[0227] The complete stack was transferred to the lens.

EXAMPLE 15

[0228] Example 14 was reproduced but using an allylic formulation using a monomer supplied by PPG under CR607 trade name, catalyzed with 3% by weight of IPP (diisopropylperoxide) and cured using a thermal cycle rising the temperature from 35° C. to 85° C. in 16 hours.

[0229] The stack was once against transferred to the lens.

EXAMPLE 16

[0230] Example 13 was reproduced but using an optical substrate composition which comprises 52 g of 1,2-bis(2-mercapto ethyl thio)-3-mercaptopropane with KSCN catalyst 190 ppm mixed with 48g of xylylene diisocyanate.

[0231] A gel is obtained at room temperature in 5 minutes, curing is achieved at 120° C. during 2 hours in air oven.

[0232] The transfer is made and a very good adhesion is found.

[0233] The performances of the lenses of examples 13 to 15 are given in Table II below.

TABLE II

Example n°	Bayer abrasion test	Steel wool test	Dry adhesion	Transmission (%)
13	5.6	2	Medium	98.9
14	7.1	9	Good	97.7
15	6.2	0	Good	99.1

[0234] Bayer abrasion resistance was determined by measuring the percent haze of a coated and uncoated lens, before and after testing on an oscillating sand abrader as in ASTM F 735-81. The abrader was oscillated for 300 cycles with approximately 500 g of aluminum oxide (Al₂O₃) ZF 152412 supplied by Specially Ceramic Grains (former Norton Materials) New Bond Street; PO Box 15137 Worcester, Mass. 01615-00137. The haze was measured using a Pacific Scientific Hazemeter model XL-211. The ratio of the uncoated lens haze (final-initial) is a measure of the performance of the coating, with a higher ratio meaning a higher abrasion resistance.

[0235] Steel wool scratch resistance was determined as follows

[0236] The lens was mounted coated surface up with double sided tape on the end of a one inch (2.54 cm) diameter pivoting rod. Steel wool (000 grade) was then pressed against the coated surface with a five pounds (2.267 kg) weight as back-pressure. The lens was then oscillated for 200 cycles against the steel wool (one inch (2.54 cm) travel), and the haze measured. The difference in haze (final-initial) as measured on a Pacific Scientific Hazemeter model XL-211 is reported as the wool scratch resistance value.

[0237] Coating adhesion was measured by cutting through the coating a series of 10 lines, spaced 1 mm apart, with a

razor, followed by a second series of 10 lines, spaced 1 mm apart, at right angles to the first series, forming a crosshatch pattern. After blowing off the crosshatch pattern with an air stream to remove any dust formed during scribing, clear cellophane tape was then applied over the crosshatch pattern, pressed down firmly, and then rapidly pulled away from coating in a direction perpendicular to the coating surface. Application and removal of fresh tape was then repeated two additional times; The lens was then submitted to tinting to determine the percentage adhesion, with tinted areas signifying adhesion failures.

[0238] Coating passes adhesion tests when percentage adhesion is more than 95%.

[0239] Transmission was measured using a BYK GARDNER Hazeguard plus hazemeter catalog n° 4725.

[0240] Impact energy was measured using a proprietary system. It can be measured by using the protocol of the FDA drop ball test with increasing weights for the ball up to the breaking of the lens or the appearance of a visual crack, generally having the shape of a star, where the ball impacted. The corresponding energy is then measured.

1. A method for transferring a hydrophobic top coat onto an optical substrate comprising the steps of:

- (a) providing a two-part plastic mold having opposed optical surfaces defining therebetween a molding cavity;
- (b) forming on at least one of the optical surfaces of the mold a hydrophobic top coat;
- (c) filling the molding cavity with an optical substrate, liquid, curable composition;
- (d) curing the liquid curable composition, and
- (e) disassembling the two-part mold for recovering a coated optical article comprising an optical substrate having deposited and adhered on at least one of its faces.

2. The method of claim 1, wherein the hydrophobic top coat is made of a silicone or a fluorosilicone.

3. The method of claim 1, wherein the hydrophobic top coat has thickness ranging from 2 to 15 nm.

4. The method of claim 1, wherein the two-part mold is made of a plastic material selected from the group consisting of polycarbonates, polyamides, polyimides, polysulfones, copolymers of polyethylene terephthalate and polycarbonate, crystal polyethylene terephthalate, glass fiber reinforced polyethylene terephthalate and polynorbornenes.

5. The method of claim 1, wherein the plastic material is polycarbonate.

6. The method of claim 1, wherein the plastic material of mold comprises a release agent.

7. The method of claim 6, wherein the release agent is selected from the group consisting of trimethylchlorosilane, chloromethyltrimethylsilane, chloropropyltrimethylsilane, chloromethyl dodecyldimethylsilane, chlorine terminated polydimethylsiloxane, (3,3-dimethylbutyl)dimethylchlorosilane, hexamethyldisilazane, octamehyl-cyclotetrasiloxane, aminopropyltrimethyl terminated polydimethylsiloxane, 3-trimethoxysilyl propyl octadecyl dimethylammonium chloride, tetradecyldimethyl (3-trimethoxysilylpropyl) ammonium chloride, trimethylethoxysilane and octadecyltrimethoxysilane.

8. The method of claim 1, further comprising, prior to step (b), a step of forming a protective coating on the optical surface of the mold.

9. The method of claim 8, wherein the protective coating is selected from:

- UV cured acrylic layer;
- an amine containing polysiloxane layer;
- a fluorocarbon polymer layer;
- a vacuum deposited magnesium fluoride layer.

10. The method of claim 1, further comprising, prior to step (c), the step of forming an anti-reflecting coating on the hydrophobic top coat.

11. The method of claim 10, wherein the anti-reflecting coating comprises a stack of dielectric material layers of alternate high and low reflective indices.

12. The method of claim 11, wherein the layers are vacuum deposited.

13. The method of claim 11, wherein the first dielectric material layer deposited directly on the hydrophobic top coat is deposited using a two-stage process in which, in a first stage, a first sub-layer of dielectric material is deposited by vacuum deposition and thereafter a second sub-layer is deposited by ion assisted vacuum deposition.

14. The method of claim 13, wherein the first dielectric material is SiO₂.

15. The method of claim 10, wherein the stack of dielectric material layers is a four layer SiO₂/ZrO₂/SiO₂/ZrO₂ stack.

16. The method of claim 13, wherein the thickness of the first sub-layer ranges from 2 to 12 nm and the thickness of the second sub-layer ranges from 68 to 98 nm.

17. The method of claim 10, further comprising the step of forming an additional SiO₂ layer onto the anti-reflecting coating for promoting adhesion to the scratch-resistant coating.

18. The method of claim 10, further comprising forming a scratch-resistant coating onto the anti-reflecting coating.

19. The method of claim 18, wherein the scratch-resistant coating is formed by curing a composition comprising as main constituents an epoxyalkoxysilane, a dialkyldialkoxysilane and colloidal silica or a hydrolyzate thereof.

20. The method of claim 19, wherein the scratch-resistant coating composition further comprises an effective amount of a coupling agent which is a pre-condensed solution of an epoxyalkoxysilane and an unsaturated alkoxy silane.

21. The method of claim 20, wherein the epoxyalkoxysilane is selected from the group of γ -glycidoxypropyltrimethoxy silane, γ -glycidoxypropylpentamethyldisiloxane, γ -glycidoxypropylmethyl-di-isopropenoxysilane, (γ -glycidoxypropyl)methyldiethoxysilane, γ -glycid-propyldimethylethoxysilane, γ -glycidoxypropyldiisopropylethoxysilane and (γ -glycidoxypropyl)bis(trimethylsiloxy)methylsilane.

22. The method of claim 20, wherein the unsaturated alkoxy silane is selected for the group consisting of tris (2-methoxyethoxy)silane, vinyl tris-isobutoxysilane, vinyl tri-t-butoxysilane, vinyltriphenoxysilane, vinyltrimethoxysilane, vinyltriisopropoxysilane, vinyltriethoxysilane, vinyltriacetoxysilane, vinylmethyl-diethoxysilane, vinylmethyl-diacetoxy-silane, vinylbis(trimethylsiloxy)silane, vinyl-dimethoxyethoxysilane, alkyltriethoxysilane, alkyltriethoxysilane and allyl-tris(trimethylsiloxy)silane, 3-acryloxypropyl-tris(trimethylsiloxy)silane, 3-acryloxypropyl-tri-

ethoxysilane, acryloxypropylmethyldimethoxysilane, 3-acryloxypropylethylbis(trimethyl-siloxy)silane, 3-acryloxypropyldimethylethoxysilane, n-(3-acryloxy-2-hydroxypropyl)-3-aminopropyltriethoxysilane, 3-methacryloxypropyltris(vinyldimethylsiloxy)silane, 3-methacryloxypropyltris(trimethylsiloxy)silane, 3-methacryloxypropyl tris(methoxyethoxy)silane, 3-methacryloxypropyltrimethoxysilane, 3-methacryloxypropylpentamethyldisiloxane, 3-methacryloxypropylmethyldimethoxysilane, 3-methacryloxypropylmethyldiethoxysilane, 3-methacryloxypropyldimethylmethoxysilane, 3-methacryloxypropyldimethylethoxysilane, 3-methacryloxypropyltrimethoxy-silane and 3-methacryloxypropylbis(trimethyl-siloxy)methylsilane.

23. The method of claim 18, further comprising forming an impact-resistant primer coating onto the scratch-resistant coating.

24. The method of claim 23, wherein the impact-resistant primer coating is formed by curing a poly(meth)acrylic based composition or a polyurethane based composition.

25. The method of claim 24, wherein the compositions are latexes.

26. The method of claim 24, wherein the impact-resistant primer coating composition comprises an effective amount of a coupling agent which is a pre-condensed solution of an epoxyalkoxysilane and an unsaturated alkoxy silane.

27. The method of claim 26, wherein the epoxyalkoxysilane is selected from the group of γ -glycidoxypropyltrimethoxysilane, γ -glycidoxypropylpentamethyldisiloxane, γ -glycidoxypropylmethyldiisopropenoxysilane, (γ -glycidoxypropyl)methyldiethoxysilane, γ -glycidoxypropyldimethylethoxysilane, γ -glycidoxypropyldiisopropylethoxysilane and (γ -glycidoxypropyl)bis(trimethylsiloxy)methylsilane.

28. The method of claim 27, wherein the unsaturated alkoxy silane is selected for the group consisting of tris(2-methoxyethoxy)silane, vinyltris(isobutoxy)silane, vinyltri(t-butoxy)silane, vinyltriphenoxysilane, vinyltrimethoxysilane, vinyltri(isopropoxy)silane, vinyltriethoxysilane, vinyltriacetoxysilane, vinylmethyldiethoxysilane, vinylmethyldiacetoxy-silane, vinylbis(trimethylsiloxy)silane, vinyl(dimethoxyethoxy)silane, allyltriethoxysilane, alkyltriethoxysilane and allyltris(trimethylsiloxy)silane, 3-acryloxypropyltris(trimethylsiloxy)silane, 3-acryloxypropyltriethoxysilane, acryloxypropylmethyldimethoxysilane, 3-acryloxypropylethylbis(trimethylsiloxy)silane, 3-acryloxypropyldimethylethoxysilane, n-(3-acryloxy-2-hydroxypropyl)-3-aminopropyltriethoxysilane, 3-methacryloxytris(vinyldimethylsiloxy)silane, 3-methacryloxypropyltris(trimethylsiloxy)silane, 3-methacryloxypropyl tris(methoxyethoxy)silane, 3-methacryloxypropyltrimethoxysilane, 3-methacryloxypropylpentamethyl disiloxane, 3-methacryloxypropylmethyldimethoxysilane, 3-methacryloxypropylmethyldiethoxysilane, 3-methacryloxypropyldimethylmethoxysilane, 3-methacryloxypropyldimethylethoxysilane, 3-methacryloxypropenyltrimethoxysilane and 3-methacryloxypropylbis(trimethylsiloxy)methylsilane.

29. The method of claim 1, wherein the optical substrate is a substrate resulting from the polymerization of:

diethyleneglycol bis(allylcarbonate) based compositions,
 (meth)acrylic monomer based compositions;
 thio(meth)acrylic monomer based compositions;
 polythiourethane precursor monomer based compositions; or
 epoxy and/or episulfide monomer based compositions.

* * * * *