

Nov. 11, 1947.

G. W. CRISE

2,430,758

HYDRAULIC LIFTING APPARATUS

Filed Nov. 18, 1944

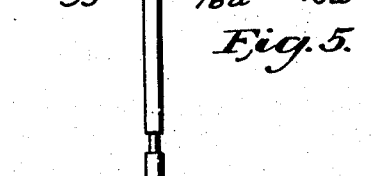
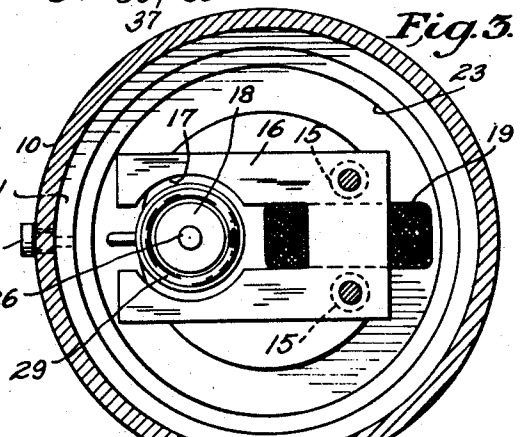
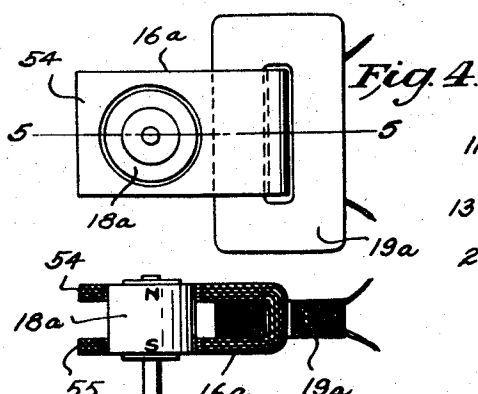
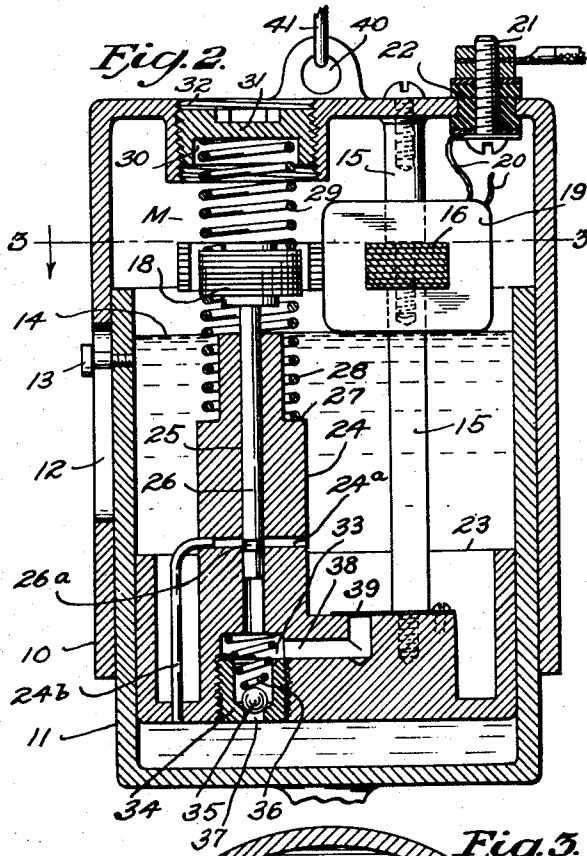
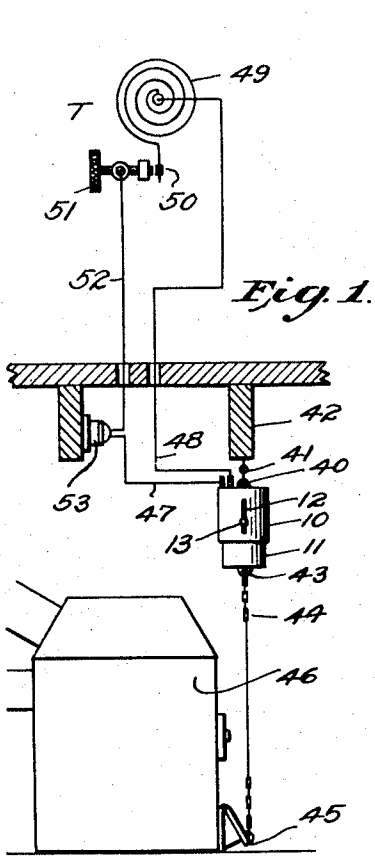

Inventor
George W. Crise

334 N. D. McNeill
Attorney

UNITED STATES PATENT OFFICE

2,430,758

HYDRAULIC LIFTING APPARATUS

George W. Crise, Columbus, Ohio, assignor to
Crise Electric Manufacturing Company, Co-
lumbus, Ohio, a corporation of Ohio

Application November 18, 1944, Serial No. 564,166

2 Claims. (Cl. 60—52)

1

The object of this invention is to provide an improved hydraulic lifter for governing the operation of furnace controls and wherein is utilized a novel type of an electrically actuated motor and pump unit.

Another object of the invention is to provide a motor pump unit wherein the shaft of a pulsating armature serves as a pump piston.

Still another object of my invention is to provide a reciprocating motor having a polarized armature, whereby the pulsating frequency of the armature is one-half that of the energizing current frequency.

An additional object of my invention is to provide a hydraulic lifter of the character set forth in which the combined motor and pump unit is supported on a piston-like base which is disposed within the cylinder structure of the lifter in relatively slidable relationship with respect thereto.

For a further understanding of the invention, reference is to be had to the following description and the accompanying drawing wherein:

Fig. 1 is an elevational view, partly in section, of the improved hydraulic lifter comprising the present invention and disclosing the same when used in association with the draft controls and room thermostat of a furnace;

Fig. 2 is an enlarged vertical sectional view taken through the hydraulic lifter showing the motor armature in its deenergized, or idle, position;

Fig. 3 is a horizontal sectional view on the plane disclosed by the line 3—3 of Fig. 2;

Fig. 4 is a plan view of a modified form of synchronous motor for use in connection with the lifter;

Fig. 5 is a sectional view on the line 5—5 of Fig. 4.

My improved hydraulic lifter, as shown more particularly in Figs. 1 to 3 of the drawings, comprises a cylinder structure composed of the telescoping members indicated at 10 and 11. The upper or outer member 10 is vertically slotted as at 12 to receive a headed pin or stud 13 projecting outwardly from the side wall of the lower member. The latter is adapted to receive and hold a suitable body of liquid, as indicated at 14.

Supported from the horizontal top wall of the outer member 10 of the casing, by means of depending posts 15, is a combined electric motor and pump mechanism M. The motor unit of this mechanism comprises a laminated stator 16 which is stationarily mounted in connection with the posts 15, the stator being formed with a circular armature cavity 17 in which is mounted

2

for pulsation or vertical reciprocation a circular armature 18, the stator being provided with a winding or coil 19 to control its excitation. This coil is joined by conductors 20 with a pair of terminal posts 21 carried by insulating bushings 22 on the upper wall of the casing member 10.

The lower ends of the posts 15 are connected with and support a piston head 23, and the lower member of the casing structure is slidably movable on and guided by said head. The head includes an upstanding extension 24 in which is formed a vertical and axially disposed bore 25, the latter receiving for sliding movement a piston stem 26. The upper end of this stem is directly and rigidly connected with the armature 18 in order that the stem will reciprocate in the bore 25 in unison with the pulsating movements of the armature 18. The extension 24 at its upper end is spaced from the armature and, additionally, is formed with an annular shoulder 27. Between the under side of the armature and the shoulder 27, there is positioned a coil spring 28. A second coil spring 29 has its lower end positioned on the upper side of the armature 18, and the upper end of the spring 29 is positioned in a circular recess 30 formed in a threaded plug 31, which is adjustably mounted in a threaded opening 32 provided in the upper casing member 10. By adjusting the plug 31, the tension of the springs 28 and 29 may be regulated so that when the motor unit is excited by a commercial alternating current source, the armature will possess a resonating frequency of sixty cycles.

The lower end of the bore 25 terminates in a chamber 33. The walls of this chamber are threaded for the reception of a valve-seating cage 34. A ball valve 35, pressed by a spring 36 arranged within the chamber 33, normally closes an orifice 37 provided in the bottom of said cage. Communicating with the upper portion of the chamber 33 is an L-shaped passage 38. The upper end of this passage is normally closed by a leaf spring valve 39. It will be seen that when the piston 26 moves upwardly, fluid will be drawn from beneath the piston head 23 and, by the opening of the ball valve 35, will be advanced into the chamber 33 and the passage 38. Upon the descent of the piston 26, the ball valve closes and the fluid contained in the chamber 33 is displaced through the passage 38, causing the elevation of the leaf spring valve 39 and the discharge of the fluid into the casing above the piston head. Since a fluid-tight seal is maintained between the adjoining surfaces of the piston head and the inner walls of the cylinder

member 11, the transfer of fluid from below to above the piston head results in creating a suction or partial vacuum within the cylinder structure, so that the external atmospheric pressure may be used in causing the elevation of the lower or movable cylinder member 11.

The piston stem 26, near its lower end, is formed with an annular groove 26a, and when the synchronous motor unit is deenergized, the coil springs 28 and 29 will approximately center the armature 18 usually slightly below the horizontal plane passing through the true center of the armature cavity 17 of the stator frame 16, causing the groove 26a to register with a small transversely extending bleed port 24a provided in the head extension 24. This permits fluid in the upper part of the movable cylinder member 11 to flow gravitationally in limited quantities through the port 24a by passing around the stem groove 26a. Communicating with the port 24a is a small pipe 24b which leads to the lower side of the piston head 23. By this arrangement, when the motor is deenergized, there is a slow and regulated return of the fluid from the upper side of the piston head to the lower side, restoring the cylinder members 10 and 11 to their normal relationship.

As a practical matter, the upper or stationary cylinder member 10 may be provided with an eye 40 in order that the same may be suspended by the use of a flexible connection 41 from an overhead supporting device such, for example, as the floor joist 42. The lower movable cylinder member 11 is also provided with an externally disposed eye 43, which may be joined by a chain or other flexible cable 44 with the movable draft-regulating door 45 of a furnace 46. The terminal posts 21, as shown in Fig. 1, may be connected with conductors 47 and 48. The conductor 48 extends from one of the terminal posts to a spirally wound bimetallic element 49 of a room thermostat T. The free end of the element 49 carries a contact 50, which is movable into and out of engagement with a stationary but adjustable contact provided on the outer end of a screw 51.

From the screw 51, a conductor 52 extends to a source of alternating current supply, as indicated at 53, and the conductor 47 leads from the other of the terminal posts to said source of current supply.

Thus when there is a demand for heat within the room or rooms of a building to be heated by the furnace 46, the bimetallic element responds to bring its contact 50 into engagement with the contact carried by the outer end of the screw, thus completing the circuit of the motor unit M. When the motor is thus energized, the armature 18 will be attracted by the field flux of the stator 16, and will rise until it reaches the center of the stator. At this time, reversal of the line current will cause the field to die out, allowing the armature to rise above the stator by virtue of its momentum and against the yielding resistance exercised by the upper coil spring 29. When the armature has risen to a point where its momentum is spent, the stator field will again be approaching a magnetic peak, drawing the armature down toward the center of the stator. Then, as the current reverses again, the stator field will die out and the armature momentum will carry it to the bottom of its travel against the yielding force of the lower spring 29, whereupon the next increase in field flux causes the cycle to be repeated.

The springs 28 and 29 are so adjusted by the plug 31 as to be in resonance with the current frequency, so that the momentum of the armature is transformed into spring tension and back into momentum with maximum efficiency as the armature pulsates up and down at the normal current frequency.

It is also noteworthy that the natural frequency of the armature as supported by the springs is unchanged by the length of the stroke or oscillating amplitude of the armature, thereby leaving the full energy of the motor available to be absorbed by the pumping load on the piston 26. As the piston moves up or down, it pumps oil or other fluid from the lower cavity of the cylinder structure past the piston head into the upper cavity, thereby drawing up the cylinder member 11 to which any suitable load, such as the draft door 45, may be connected. It will be understood, however, that this load may be in any desired form, such, for example, as a valve, check damper or the like.

In Figs. 4 and 5, the oscillating motor has been designed for half frequency operation, employing a polarized armature 18a, the latter having its opposite ends magnetized to opposite polarity and constructed of a solid cylinder of high flux alloy, or of a solid cylinder with laminated disk ends, depending on the size and efficiency of the motor units desired. The stator 16a is composed of laminated electrical steel with a field coil 19a so placed as to provide an alternating field with the stator poles 54 and 55 surrounding the ends of the permanently polarized armature 18a when the armature is in its normal or rest position. This half frequency motor is otherwise provided with the synchronizing springs 28 and 29 and other associated means as set forth in Fig. 1.

I claim:

1. Hydraulic lifting apparatus comprising a casing having telescoping upper and lower sections, a piston mounted within and slidably engaging the inner wall surfaces of the lower wall section, said piston being provided with a passageway for the transmission of fluid contained within the casing from one side to the other of the piston, the latter being further formed with a bore communicating at its lower end with said passageway, a stem reciprocable in said bore, self-closing valves cooperative with said passageway on opposite sides of its region of communication with said bore and operable upon reciprocatory movement of said stem to provide for the passage of fluid displaced by said stem from beneath said piston to above the same, frame means stationarily uniting said piston with said upper section, an electrically energized oscillating motor, the latter embodying a stator mounted on said frame means, an armature mechanically joined with said stem, balancing springs for said armature, one of said springs being disposed between the upper end of said armature and said upper section and the other of said springs being disposed between the lower side of said armature and said piston, and a fluid return passage of reduced cross sectional area as compared with said first-named passageway formed in said piston for transferring fluid contained in said casing from the upper side of said piston to the lower side thereof, said last-named passage being automatically opened when said motor is deenergized and the armature thereof is balanced by said springs.

2. Hydraulic lifting apparatus comprising a casing having telescoping upper and lower sec-

5

tions, a piston mounted within and slidably engaging the inner wall surfaces of the lower wall section, said piston being provided with a passageway for the transmission of fluid contained within the casing from one side to the other of the piston, the latter being further formed with a bore communicating at its lower end with said passageway, a stem reciprocable in said bore, self-closing valves cooperative with said passageway on opposite sides of its region of communication with said bore and operable upon reciprocatory movement of said stem to provide for the passage of fluid displaced by said stem from beneath said piston to above the same, frame means stationarily uniting said piston with said upper section, an electrically energized oscillating motor, the latter embodying a stator mounted on said frame means, an armature mechanically joined with said stem, balancing springs for said armature, one of said springs being disposed between the upper end of said armature and said upper section and the other of said springs being disposed between the lower side of said armature and said piston, a fluid return passage of reduced cross sectional area as compared with said first-named passageway formed in said piston for transferring fluid contained in said casing from the upper side of said piston to the lower side thereof, said last-named passage being automatically opened when

6

said motor is deenergized and the armature thereof is balanced by said springs, an operating circuit for said motor, and a thermostatically controlled switch positioned in said circuit.

GEORGE W. CRISE.

REFERENCES CITED

The following references are of record in the file of this patent:

UNITED STATES PATENTS

Number	Name	Date
151,670	Ojeda	June 2, 1874
404,418	Kiskadden	June 4, 1889
431,493	Van Depocle	June 1, 1890
2,003,647	Dillstrom	June 24, 1935
2,022,035	Grob	Nov. 26, 1935
2,146,403	Nilson	Feb. 7, 1939
2,225,515	Wood	Dec. 17, 1940
Re. 20,510	Green	Sept. 21, 1937

FOREIGN PATENTS

Number	Country	Date
580,159	Germany	1933
122,421	Switzerland	1927

OTHER REFERENCES

Serial No. 366,364, Wunsch (A. P. C.), pub. Apr. 27, 1943.