

(No Model.)

E. C. FASOLDT.
METALLIC PISTON PACKING.

No. 441,866.

Patented Dec. 2, 1890.

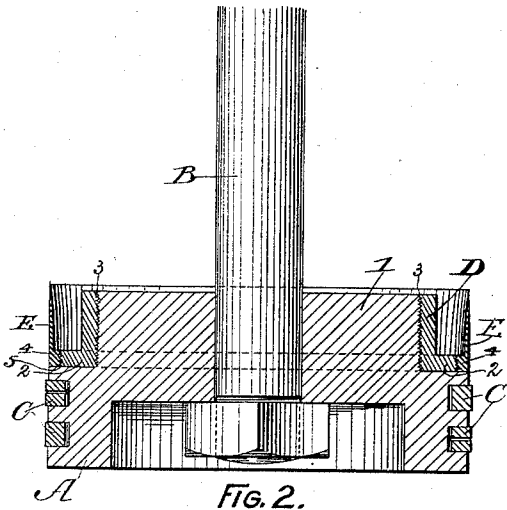

FIG. 2.

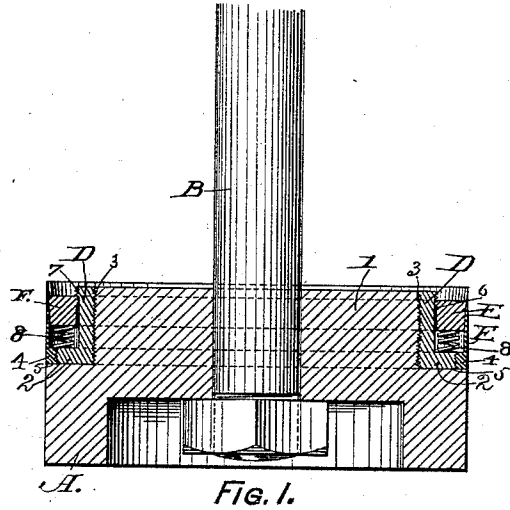

FIG. 1.

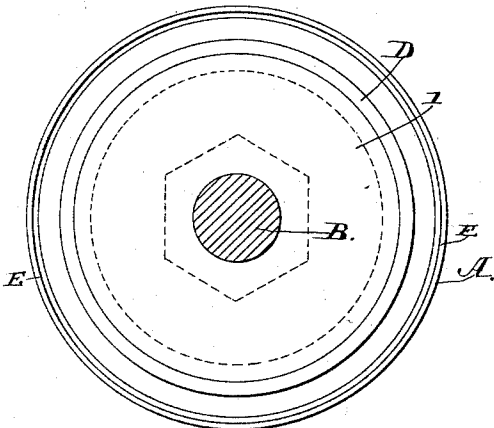

FIG. 3.

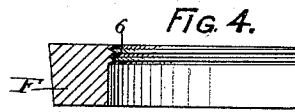

FIG. 4.

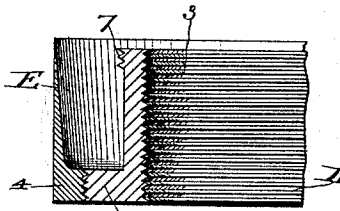

FIG. 5.

Witnesses:

S. B. Bainter,
H. V. Scattergood

Inventor:

ERNEST C. FASOLDT,

by

William H. Low

Attorney.

UNITED STATES PATENT OFFICE.

ERNEST C. FASOLDT, OF ALBANY, NEW YORK, ASSIGNOR OF ONE-HALF TO
JOHN BOYD THACHER, OF SAME PLACE.

METALLIC PISTON-PACKING.

SPECIFICATION forming part of Letters Patent No. 441,866, dated December 2, 1890.

Application filed September 17, 1889. Serial No. 324,188. (No model.)

To all whom it may concern:

Be it known that I, ERNEST C. FASOLDT, of the city and county of Albany, in the State of New York, have invented new and useful
5 Improvements in Metallic Packing for the Pistons of Air-Compressing Pumps, of which the following is a specification.

This invention relates to metallic packing
10 for pumps for compressing air, but especially for the class of such pumps as are employed for compressing air to a high degree of density, wherein much difficulty is encountered in obtaining a piston-packing sufficiently tight to
15 prevent a leakage that renders the obtainment of the required pressure a matter of great and sometimes of insurmountable difficulty.

The object of my invention is to provide a
20 metallic packing that will remedy the difficulty above named, and I attain this object by the means illustrated in the accompanying drawings, which are herein referred to, and form a part of this specification, in which—

Figure 1 is a vertical section of a piston
25 provided with the preferred form of my packing. Fig. 2 is a like section of a modified form of the same. Fig. 3 is a plan view of Fig. 2, and Figs. 4 and 5 are enlarged and detached vertical sections of my packing-rings
30 illustrated in Fig. 1.

As represented in the drawings, A designates a piston-head, which may be of the form shown in the drawings or in any other form suitable for the purpose, and B is the
35 piston-rod, to which said piston-head is secured by any of the common and well-known means of effecting such attachment. The upper portion of said piston-head is reduced in diameter to form the hub 1, upon the periphery of which a screw-thread is cut for the
40 purpose of receiving my packing. When preferred, the piston-head A may be provided with spring-rings C of the form commonly employed for packing such pistons.

D is a cylindrical ring provided with a circumferential flange 2, having a screw-thread cut around its periphery. The bore of the ring D is provided with a screw-thread 3,
50 which is fitted to screw onto the corresponding thread cut on the hub 1, so as to effect

the attachment of said ring to the piston-head A.

E is the packing-ring, having a diameter that fits the bore of the air-pump in which it is to be used. Said packing-ring has a conical bore, so as to leave a very slight thickness—approximating a knife-edge—at its upper end, and then gradually increasing in thickness toward the lower end, at which point
55 a re-enforcing belt 4 is formed on the inner side in order to obtain sufficient strength to cut a screw-thread therein, said screw-thread being fitted to screw onto the corresponding screw-thread of the flange 2, so as to form a
60 close joint between the lower end of said packing-ring and the shoulder 5 of the piston-head.

F is a loose ring inserted between the bore of the packing-ring E and the outer face of the ring D. The perimeter of said ring is
70 made coniform to correspond to the bore of the packing-ring E. Said ring is preferably supported on light springs 8 of sufficient strength to support the weight of said ring. The bore of said ring is provided at its upper
75 end with screw-threads 6, which correspond to screw-threads 7, which are cut on the upper end of the perimeter of the cylindrical ring D. The lower portion of the bore of the
80 ring F is of sufficient diameter to slip easily over the screw-threads 7, and the lower portion of the perimeter of the body of the ring D is smooth and of such diameter that the screw-threaded portion of the ring F will slip
85 freely up and down thereon. The upper surface of the ring F receives the pressure of the compressed air and forces said ring downwardly into the annular space formed between the rings D and E, and thereby effects
90 the expansion of the packing-ring E, respectively of the expansion produced by the pressure of the compressed air acting against the inner surface of said ring.

In the packing shown in Fig. 2 the cylindrical ring D is made without the screw-threads 7, (shown in Fig. 1,) and the ring F
95 (also shown in Fig. 1) is dispensed with, the pressure of the compressed air against the inner side of the ring E being relied upon to expand the packing-ring to closely fit the
100

bore of the air-pump. This form of packing is found sufficient where a pressure of about a thousand pounds to the square inch is only required. When a pressure is required to exceed that figure, I prefer the form of packing shown in Fig. 1. When preferred, the rings D and E can be made integral; but when they are made separately, as shown in the drawings, the ring E can be readily replaced without removing the ring D. When the former has become worn by use and when preferred, the ring E can be spun up out of sheet metal, and in the latter case it should have an internal flat flange fitted to engage under the lower end of the ring D. In some cases—as when the screw-threads 7 are omitted—the ring D may be dispensed with by increasing the diameter of the hub 1 to fill the space occupied by said ring, and thereby the construction will be considerably simplified.

What I claim as my invention, and desire to secure by Letters Patent, is—

1. A metallic packing for pistons of air-compressing pumps, consisting of an inner metallic ring or head of cylindrical form and an

outer metallic ring that is used intact and unslitted, but is expansible by the pressure of the compressed air contained in the pump, said inner and outer rings being formed or connected together so as to form an annular groove between them, as and for the purpose herein specified.

2. A metallic packing for pistons of air-compressing pumps, consisting of an inner metallic ring or head of cylindrical form and an outer metallic ring having a coniform bore and being expansible by the pressure of the compressed air contained in the pump, said inner and outer rings being formed or connected together so as to form an annular groove between them, and an intermediate ring having a coniform perimeter which conforms to the bore of the outer packing-ring placed in said annular groove to effect the forcible expansion of said outer ring, as and for the purpose herein specified.

ERNEST C. FASOLDT.

Witnesses:

WM. H. LOW,
S. B. BREWER.