

No. 611,081.

Patented Sept. 20, 1898.

J. SCHNEIBLE.

METHOD OF AND APPARATUS FOR COLLECTING AND PURIFYING GAS.

(Application filed June 11, 1895. Renewed Feb. 10, 1898.)

(No Model.)

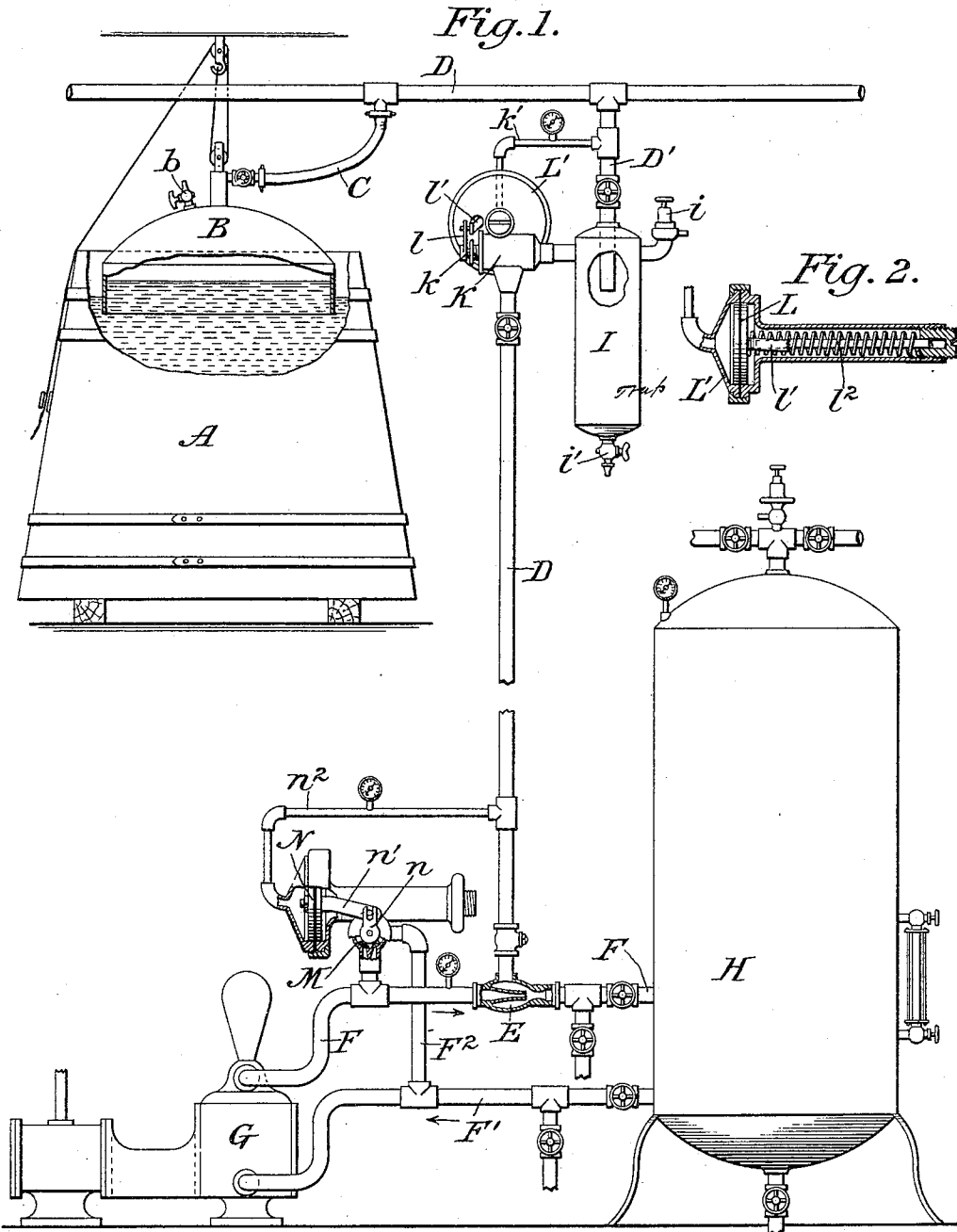

Attest:
A. K. Jesbera
S. H. Irish.

Inventor:
Joseph Schneible
by Redding & Kiddle
Attys.

UNITED STATES PATENT OFFICE.

JOSEPH SCHNEIBLE, OF NEW YORK, N. Y.

METHOD OF AND APPARATUS FOR COLLECTING AND PURIFYING GAS.

SPECIFICATION forming part of Letters Patent No. 611,081, dated September 20, 1898.

Application filed June 11, 1895. Renewed February 10, 1898. Serial No. 669,864. (No model.)

To all whom it may concern:

Be it known that I, JOSEPH SCHNEIBLE, a citizen of the United States, and a resident of the city and county of New York, State of New York, have invented certain new and useful Improvements in Methods of and Apparatus for Collecting and Purifying Gas, of which the following is a specification, reference being had to the accompanying drawings, forming a part thereof.

This invention relates particularly to the collection of carbon dioxide as it is produced by fermentation; and it has for its object to enable such gas to be collected, purified, and stored under pressure in readiness for use without interfering with the ordinary operations of brewing or other fermentation of liquors and without requiring any variation in existing conditions, apparatus, appliances, or methods. The apparatus which has been devised for this purpose is so constructed and arranged as to be automatic or self-regulating in operation, so that when the most favorable conditions for the collection of gas have been determined upon such conditions will not need to be altered from time to time as the production of the gas varies, as in practice it does. In the practice of the invention the gas is collected from its various sources of production, is caused to flow through a pipe-line or suitable conductor to a point where it is washed, and is then delivered to a suitable receptacle, where it is more or less compressed, the collection, purification, and storing being effected in a single continuous operation. The gas might flow through the conductor as it is given off; but it is preferable to aid the flow and keep it more constant and uniform by maintaining in the pipe-line or conductor a tension perhaps slightly less than that of the atmosphere. Moreover, such maintaining of a low pressure in the conductor is readily effected by reason of the fact that the gas is drawn by an aspirator or other like device, in which it is mixed with water and washed and by which it is at the same time delivered into the receiving-tank and there more or less compressed. Such an arrangement as that just referred to also enables the several acts to be performed with a minimum of apparatus and that of the sim-

plest character, comprising mainly a collecting-hood or its equivalent, a pipe-line or conductor connected thereto, an aspirator or like device coupled to said pipe-line or conductor, with means for forcing water or other liquid through it, and a tank or receptacle into which the mingled water or other liquid and gas are conducted and in which the separation of the gas from the water or other liquid takes place, while the water or other liquid is used over and over again. To this fundamental apparatus are added certain regulating devices to be hereinafter described, which render its operation automatic, regular, and constant, notwithstanding variations in supply of gas, and which prevent any alteration of the conditions of production and collection which have been found to be favorable.

In the accompanying drawings the invention is illustrated as embodied in an approved form of apparatus, although it is to be understood that the invention is not limited to the details shown nor, as to the method herein set forth, to any particular apparatus.

In the drawings, Figure 1 is a view, partly in elevation and partly in section, of apparatus embodying the invention, the relative size and exact relation of parts being disregarded in order to save space. Fig. 2 is a detail view, partly in section, illustrating one of the regulating devices.

A fermenting-vat such as is commonly used in breweries is represented at A in Fig. 1 as the source of supply of the gas to be collected, washed, and stored under pressure, although, as is obvious, the gas may be derived from any source. From the surface of the liquid in this vat the gas is given off more or less freely and may be gathered in a hood B, which is conveniently supported by a block and tackle and is provided with a vent-cock *b*, which may be opened to permit the escape of the air with which the hood is filled at the outset and to permit the lower edge of the hood to be sunk beneath the surface of the liquid, and is connected by a flexible pipe C with a pipe-line or conductor D, to which other hoods may also be connected in like manner. At E is indicated an aspirator or jet-pump or other device of like character, and it may be of usual construction, to which the gas is de-

livered from the pipe-line or conductor D, the water or other liquid which operates the aspirator and at the same time is mingled with and washes the gas being delivered to the aspirator through a pipe F from a pump G, of suitable construction, or from any other suitable source. The pipe F is continued beyond the aspirator and delivers the mingled gas and liquid to the closed tank H, in which the gas is received and compressed somewhat and from the upper part of which it may be discharged or conducted to the place of use. The surface of the liquid in the tank is preferably maintained at a higher level than the mouth of the pipe F, so that the same may be always covered, and the water or other liquid itself is preferably discharged or returned from the lower portion to the pump G through a pipe F' and thereby kept in circulation until it becomes necessary to change the same.

It will be understood from the foregoing description that as the water is forced through the aspirator E the gas is drawn into and mingled with the flowing stream of water and is washed thereby, while at the same time a tension less than atmospheric is maintained in the pipe-line or conductor, and the mingled gas and liquid are delivered into the receptacle H under a pressure which is above the atmospheric pressure and is determined by the power of the aspirator. It will be evident to those having knowledge of the laws which govern the absorption of gas by liquids that while more or less gas will be set free in the very beginning of the operation as soon as the mingled gas and liquid enter the tank H the liquid being used over and over again will soon become saturated to its full capacity, and thereafter all or substantially all of the gas which is drawn in through the aspirator and mingled and washed with and by the liquid in its passage from the aspirator to the tank will be set free in the tank and will be compressed therein more or less, according to the power of the aspirator.

If the apparatus were operated in the form already described and without the addition of controlling means, it would frequently happen either that the gas would be given off more rapidly than it could be taken up by the aspirator, and hence would bubble out from under the edge of the hood B, thereby disturbing the liquid in the fermenting-vat, or that the gas would be given off less rapidly than it could be disposed of by the aspirator and with the result that the pressure on the surface of the fermenting liquid would be reduced too much below the atmospheric pressure or that which has been found to give the most satisfactory results, or that by varying pressure or tension the conditions under which the gas is given off might be varied to the detriment of the brewing or other main operation. Accordingly self-regulating devices are provided, which will prevent the un-

desirable conditions just referred to. These devices will now be described.

As indicated in Fig. 1, a branch D' of pipe-line D opens into a closed vessel I, which is equipped with a safety-valve *i* and a draw-off cock *i'*, while the pipe-line is continued from the top of the vessel I. This vessel therefore constitutes a trap for the collection and removal of whatever vapors may be carried off with the gas from the fermenting-tubs and condensed in the pipe-line. At K a valve is inserted in the pipe-line, the stem *k* of the valve being connected by a crank-arm *l'* to a diaphragm L, inclosed in a casing L', which communicates through a pipe *k'* with the pipe-line D at a point in advance of the valve. The diaphragm is also subject to the pressure of a spring *l²*, so that its action may be regulated. If the gas is being given off less freely, the pressure upon the diaphragm will be at once decreased by reason of the continuous action of the aspirator. This condition would be attended with the undesirable result above referred to but for the fact that the valve is partly or wholly closed at once by the movement of the diaphragm, and consequently prevents any material reduction of pressure in the collecting-hoods. On the other hand, should the gas be given off more freely than usual the diaphragm will move in the opposite direction and will open the valve more widely. By means of the spring and its adjusting devices the pressure at which the valve shall open or close may be determined exactly.

It is necessary also for the best results that the action of the aspirator should be regulated automatically according to variations in the supply of gas and the consequent variations of pressure within the pipe-line. In the arrangement shown it is preferred to accomplish this result not by direct action upon the aspirator, but by controlling the operation of the pump or rather of the flow of liquid from the pump. Accordingly I have established a connection F² between the delivery-pipe F and the suction-pipe F' and have inserted in such connection a valve M, which, through crank-arm *n* and link *n'*, is controlled by a diaphragm N, which, through a connection *n²*, is moved or affected by variations of pressure in the pipe-line before or in advance of the aspirator. If the pressure in the pipe-line decreases too much, the diaphragm opens the valve and therefore permits more or less of the water to be returned directly to the suction-pipe F' without being passed through the aspirator. On the other hand, if the pressure on the diaphragm rises, indicating an excess in the supply of gas, the valve will be closed wholly or partly and all of the water compelled to pass through the aspirator, so that its power shall be increased to take up, wash, and deliver more gas. Thus under all conditions of operation there is maintained on the gas a substantially uniform

tension regardless of the quantity of the supply, whereby it becomes possible to collect, wash, and store or use the gas of fermentation without any interference with those conditions of fermentation which have been predetermined.

It will be readily understood that the pressure-controlling devices indicated at K and L are supplementary to the devices by which the variations of pressure are caused to vary the action of the aspirator and are used, if at all, as an additional safeguard against the undesirable effects of a sudden or marked variation in the flow of the gas. Such means may therefore be dispensed with.

It will also be understood that the details of construction of the parts of the apparatus—such, for example, as the regulating devices—are not material in the present invention and may be varied as desired.

What I claim, and desire to secure by Letters Patent, is—

1. The method of collecting gas which consists in supplying a continuous stream of liquid, causing the liquid to draw the gas from its source of supply and causing the variations in the supply of gas to vary the action of the liquid in drawing the gas, whereby a substantially constant tension is maintained on the gas and the conditions of the production of the gas are not interfered with.

2. The method of collecting gas which consists in conducting the gas from its source to a jet-pump or aspirator, forcing a stream of liquid through said jet-pump or aspirator and thereby drawing and mingling the gas with the liquid, causing the variations in the supply of gas to vary the action of the aspirator discharging the liquid and gas together into a closed vessel, permitting the gas to separate from the liquid in the closed vessel, discharging the gas from the upper part of the vessel and discharging the liquid from the lower part thereof.

3. An apparatus for collecting gas comprising a hood or collector to receive the gas, a jet-pump or aspirator, a pipe to conduct the gas from the collector to the jet-pump or aspirator, means to force a stream of liquid through the jet-pump or aspirator, a closed tank into which the gas and liquid are discharged by said jet-pump or aspirator, said tank having an outlet for the gas, and a return connection from said tank to said means for forcing the liquid, whereby the same liquid may be used over and over again, substantially as set forth.

4. An apparatus for collecting gas comprising a hood or collector to receive the gas, a jet-pump or aspirator, a pipe to conduct the gas from the collector to the jet-pump or aspirator, a force-pump to force a stream of liquid through the jet-pump or aspirator, a closed tank into which the gas and liquid are discharged by said jet-pump or aspirator, said tank having an outlet for the gas, and a return connection from said tank to said

force-pump whereby the same liquid may be used over and over again, substantially as set forth.

5. An apparatus for collecting gas comprising a hood or collector to receive the gas, a jet-pump or aspirator, a pipe to conduct the gas from the collector to the jet-pump or aspirator, means to force a stream of liquid through the jet-pump or aspirator, a valve to regulate the action of the aspirator, a diaphragm actuated by variations in the gas-supply and connections therefrom to said valve to vary the action of the jet-pump or aspirator and a closed tank into which the gas and liquid are discharged by said jet-pump, said tank having an outlet for the gas, substantially as set forth.

6. An apparatus for collecting gas comprising a hood or collector to receive the gas, a jet-pump or aspirator, a pipe to conduct the gas from the collector to the jet-pump or aspirator, means to force a stream of liquid through the jet-pump or aspirator, a valve to regulate the delivery of the liquid to the jet-pump or aspirator, a diaphragm adapted to move as the supply of gas varies and to shift said valve, whereby the action of the aspirator varies with the supply of gas, and a closed tank into which the gas and liquid are discharged by said jet-pump or aspirator, said tank having an outlet for the gas, substantially as set forth.

7. An apparatus for collecting gas comprising a hood or collector to receive the gas, a jet-pump or aspirator, a pipe to conduct the gas from the collector to said jet-pump or aspirator, a force-pump to force a stream of liquid through the jet-pump or aspirator, a closed tank into which the gas and liquid are discharged by said jet-pump or aspirator, said tank having an outlet for the gas, a return connection from said tank to said force-pump, a branch from the delivery of said force-pump to said return connection, a valve to regulate the passage of liquid through said branch and means actuated by variations in the supply of gas to shift said valve.

8. An apparatus for collecting gas comprising a hood or collector to receive the gas, a pipe to conduct the gas therefrom, means to deliver a stream of liquid under pressure, a mixing device in which the gas and liquid are mingled, a closed tank into which the gas and liquid are delivered from said mixing device, said tank having an outlet for the gas and a device actuated by variations in the gas-supply to vary the delivery of liquid to said mixing device, substantially as set forth.

9. An apparatus for collecting gas comprising a hood or collector to receive the gas, a pipe to conduct the gas therefrom, means to deliver a stream of liquid under pressure, a mixing device in which the gas and liquid are mingled a closed tank into which the gas and liquid are delivered from said mixing device, said tank having an outlet for the gas, a valve to regulate the delivery of liquid to

said mixing device and a diaphragm adapted to move as the supply of gas varies to shift said valve whereby the delivery of liquid to the mixing device varies as the supply of gas varies, substantially as set forth.

5
10
15
20 10. An apparatus for collecting gas comprising a hood or collector to receive the gas, a jet-pump or aspirator, a pipe to conduct the gas from the collector to the jet-pump or aspirator, means to force a stream of liquid through the jet-pump or aspirator, a closed tank into which the gas and liquid are discharged by said jet-pump or aspirator, said device interposed between the gas-collector and the aspirator adapted to be actuated by variations in the supply of gas to control the delivery of gas to the aspirator, substantially as set forth.

20 11. An apparatus for collecting gas com-

prising a hood or collector to receive the gas, a jet-pump or aspirator, a pipe to conduct the gas from the collector to the jet-pump or aspirator, means to force a stream of liquid through the jet-pump or aspirator, a closed tank into which the gas and liquid are discharged by said jet-pump or aspirator, said tank having an outlet for the gas, a valve interposed in the gas-conductor between the collector and the jet-pump or aspirator to control the flow of gas and a diaphragm adapted to move as the supply of gas varies and to shift said valve, substantially as set forth.

This specification signed and witnessed this 10th day of June, A. D. 1895.

JOSEPH SCHNEIBLE.

In presence of—

WILLIAM B. GREELEY,
ALFRED W. KIDDLE.