

(19) World Intellectual Property Organization
International Bureau



(43) International Publication Date
6 March 2003 (06.03.2003)

PCT

(10) International Publication Number
WO 03/018954 A1

(51) International Patent Classification⁷: E21B 21/06

[GB/US]; 79 Chachapacassett Road, Barrington, RI 02806 (US).

(21) International Application Number: PCT/US02/27266

(74) Agents: BURGAN, Jeffrey, B. et al.; Leydig, Voit & Mayer, Ltd., Suite 4900, Two Prudential Plaza, 180 North Stetson, Chicago, IL 60601-6780 (US).

(22) International Filing Date: 27 August 2002 (27.08.2002)

(25) Filing Language: English

(81) Designated States (national): AE, AG, AL, AM, AT, AU, AZ, BA, BB, BG, BR, BY, BZ, CA, CH, CN, CO, CR, CU, CZ, DE, DK, DM, DZ, EC, EE, ES, FI, GB, GD, GE, GH, GM, HR, HU, ID, IL, IN, IS, JP, KE, KG, KP, KR, KZ, LC, LK, LR, LS, LT, LU, LV, MA, MD, MG, MK, MN, MW, MX, MZ, NO, NZ, OM, PH, PL, PT, RO, RU, SD, SE, SG, SI, SK, SL, TJ, TM, TN, TR, TT, TZ, UA, UG, US, UZ, VC, VN, YU, ZA, ZM, ZW.

(26) Publication Language: English

(30) Priority Data:
60/315,392 27 August 2001 (27.08.2001) US
60/332,620 14 November 2001 (14.11.2001) US

(71) Applicant (for all designated States except US): APV NORTH AMERICA, INC. [US/US]; 9525 W. Bryn Mawr Avenue, Rosemont, IL 60018 (US).

(84) Designated States (regional): ARIPO patent (GH, GM, KE, LS, MW, MZ, SD, SL, SZ, TZ, UG, ZM, ZW), Eurasian patent (AM, AZ, BY, KG, KZ, MD, RU, TJ, TM), European patent (AT, BE, BG, CH, CY, CZ, DE, DK, EE, ES, FI, FR, GB, GR, IE, IT, LU, MC, NL, PT, SE, SK,

(72) Inventor; and

(75) Inventor/Applicant (for US only): GIBSON, Stewart

[Continued on next page]

(54) Title: SYSTEM AND METHOD FOR PROCESSING CUTTINGS POLLUTED WITH OIL-BASED MUD

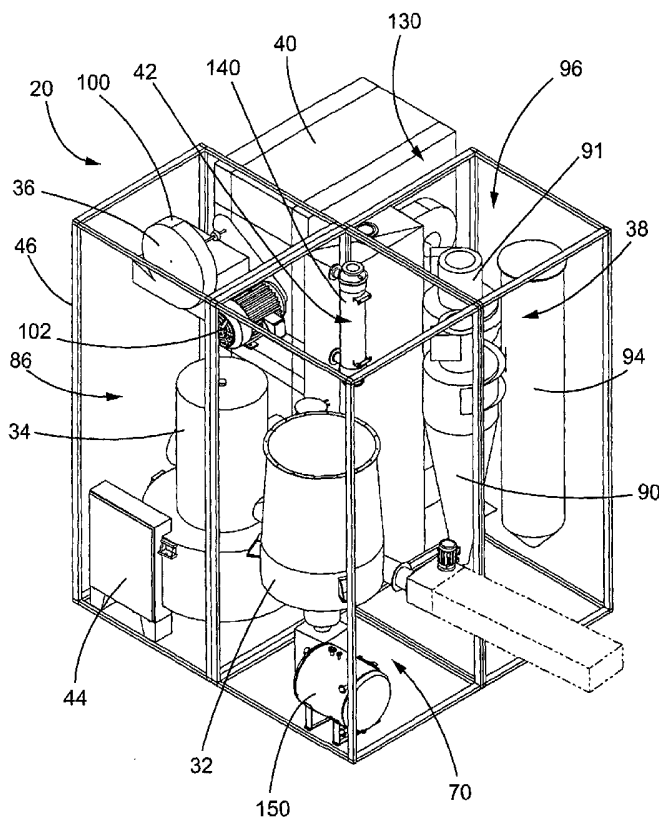

(57) Abstract: A cuttings processing system for treating cuttings produced while drilling wells using a drilling mud containing a hydrocarbon and a method for using the same are disclosed. The processing system includes a spin flash drying chamber (34) and can include also a fan (36), a solids removal system (38) and a heater. The fan can be configured to circulate the vapor within the system. The solids removal system can be configured to remove particulates from the vapor to provide filtered vapor. A heater is provided to heat the filtered vapor into the superheated region. The heater can be associated with the solids removal system to receive the filtered vapor therefrom. The drying chamber is configured to receive the cuttings. The drying chamber is connected to the heater to receive the superheated and filtered vapor therefrom to promote the emitting of the vapor from the cuttings. The drying chamber is connected to the solids removal system to convey the vapor and dried particulated thereto to form a substantially closed loop.

WO 03/018954 A1



TR), OAPI patent (BF, BJ, CF, CG, CI, CM, GA, GN, GQ, GW, ML, MR, NE, SN, TD, TG).

For two-letter codes and other abbreviations, refer to the "Guidance Notes on Codes and Abbreviations" appearing at the beginning of each regular issue of the PCT Gazette.

Published:

— *with international search report*

SYSTEM AND METHOD FOR PROCESSING CUTTINGS POLLUTED WITH OIL-BASED MUD

CROSS-REFERENCE TO RELATED PATENT APPLICATIONS

[0001] This patent application claims the benefit of U.S. Provisional Patent Application No. 60/332,620, filed November 14, 2001, and entitled "System and Method for Processing Oil-Based Cuttings," and U.S. Provisional Patent Application No. 60/315,392, filed August 27, 2001, and entitled "Processing of Oil Based Mud Cuttings," which are incorporated in their entireties herein by this reference.

FIELD OF THE INVENTION

[0002] The invention relates to an efficient system and method for removing volatile hydrocarbons from solids/hydrocarbon mixtures. In particular, the invention relates to a spin flash drying system and a method for using spin flash drying to process hydrocarbon-based drilling fluids and cuttings which result from drilling oil and/or gas wells using petroleum-based drilling fluids.

BACKGROUND OF THE INVENTION

[0003] Oil drilling operations frequently require the use of drilling fluids that contain hydrocarbons, such as petroleum-based drilling fluids, for example. Such fluids are often generically called oil-based muds. These drilling fluids are used to avoid contamination and swelling of certain strata. During drilling, cuttings are produced from the drilling hole. These cuttings are coated with unacceptable levels of hydrocarbons such as oil from the drilling mud which present environmental problems in their disposal. These cuttings can initially contain as much as 15%-20% hydrocarbons as well as water. Such cuttings present special disposal problems when produced during the drilling of offshore wells.

[0004] When drilling offshore, the typical practice is to transport these cuttings via service vessels from the rig to shore. Thereafter, the cuttings are processed by heating to around 600°F. The oil and water are vaporized in this process. The vapors are then condensed, and the liquids separated by gravity. The recovered oil can be used as fuel or to produce more drilling mud. The recovered water is cleaned and disposed. The residual clean cuttings can be incorporated into building materials, such as concrete, blocks, fill, and the like.

[0005] There is considerable cost, a risk to the environment, and some degree of danger involved in transporting cuttings to shore for treatment. Furthermore, regulatory authorities can require payment of a duty and can demand that the recovered oil be transported to a fossil fuel power station, often several hundred miles away, thereby presenting additional cost in management and in transportation.

[0006] In addition, planned legislation will prohibit the disposal of drilling cuttings into the ocean unless the residual hydrocarbons are less than 1%. Certain entities have already started following this proposed practice.

[0007] Present processing technologies include the use of thermal fluid at approx 700°F in a rotating disc drum or "Porcupine." However, the equipment is hard to maintain due to a large number of moving parts and is too heavy to be operated offshore. The oil content in the discharged cuttings from the present drying technology can be inconsistent due to changing water content and the large material inventory contained within the drum.

[0008] The present invention is addressed toward overcoming these drawbacks.

SUMMARY OF THE INVENTION

[0009] The present invention is directed particularly to a system and method for processing cuttings produced while drilling with hydrocarbon-containing drilling muds such as oil-based muds. In particular, the present invention relates to a spin flash drying system that can be operated *in situ*, *i.e.*, on or near a rig itself, including offshore drilling rigs and platforms. The cuttings processing system of the present invention operates under a closed cycle with a superheated steam atmosphere. The system is also useful for removing volatile hydrocarbons from a variety of solids/hydrocarbon streams where separation is desired.

[0010] The processing system is centered around a spin flash drying chamber. The system further preferably includes a feed vat, a fan, a solids removal system, a heater, and a collection system. The fan is preferably configured to circulate the vapor within the system. The solids removal system can be configured to remove dried particulates from the vapor to provide filtered vapor. The solids removal system can be operably engaged with the piping such that the fan circulates the vapor to the solids removal system. The heater can be provided to heat steam and/or the filtered vapor into the superheated region. The heater can be associated with the solids removal system to receive the filtered vapor therefrom.

[0011] The spin flash drying chamber is configured to receive the cuttings. The drying chamber is connected to the heater to receive the superheated steam and/or filtered vapor therefrom to promote the emitting of further vapor from the cuttings processed in the chamber. The drying chamber is preferably connected to the solids removal system to convey the vapor thereto to form a substantially closed loop.

[0012] A collection system is preferably provided to receive at least a portion of the filtered vapor and includes a condenser for condensing the vapor into a condensate. The condensate can separate into portions of oil and water which can be respectively pumped from a decanter for further treatment and/or re-use.

[0013] In addition the cuttings processing system of the present invention can be housed in a container system for use off-shore at the point of the cuttings generation. Thus, the

invention can be used as a containerized system, for operation in the "safe zone" of a drilling platform so that off-shore cuttings processing can be achieved.

[0014] In another aspect of the invention, a fully automated control system is provided to monitor the system.

[0015] This system can be used to perform a process for the remediation of cuttings produced from drilling operations, particularly those contaminated with oil and other hydrocarbons resulting from the use of oil-based drilling mud. The process is also applicable for remediation of contaminated soil, fine sand, or silt resulting from oil leakage or spills.

[0016] In one embodiment, a process according to the present invention can be used to treat hydrocarbon contaminated cuttings which emit vapor. The process preferably includes storing the cuttings in a feed vat which is connected to a spin flash drying chamber. The cuttings can be conveyed from the feed vat to the drying chamber. The cuttings are dried in the drying chamber to eliminate hydrocarbons from the cuttings. The hydrocarbons and any water are released as vapor. The dried particulates are removed from the vapor using a solids removal system that may include filters, cyclones or other suitable solids removal equipment. Some or all of the released vapor is recycled to be heated back into a superheated region. The superheated vapor is then returned to the drying chamber to form a closed loop. At least a portion of the vapor can be condensed to form a condensate which includes at least a portion of hydrocarbons such as oil and at least a portion of water. The condensate can be collected in a collection system. The oil and the water of the condensate can be separated for further treatment and/or re-use.

[0017] The cuttings processing system of the present invention can be implemented for *in situ* treatment of older, existing dumps containing oil-based cuttings, for example. Often such dumps are located on the seabed adjacent to older drill sites. These dumps can still exude oil, causing long term environmental concern. The operation of the spin flash drying system on a barge anchored over the site, for example, can make it feasible to process these materials. In some instances, the recovered oil may be used to fire the burners and diesel generators on board the barge.

[0018] The features of the present invention will become apparent to one of ordinary skill in the art upon reading the detailed description, in conjunction with the accompanying drawings, provided herein.

BRIEF DESCRIPTION OF THE DRAWINGS

[0019] FIG. 1 is a perspective view of a cuttings processing system in accordance with the present invention.

- [0020] FIG. 2 is a front elevational view of the cuttings processing system of FIG. 1.
- [0021] FIG. 3 is a side elevational view of the cuttings processing system of FIG. 1.
- [0022] FIG. 4 is a top plan view of the cuttings processing system of FIG. 1.
- [0023] FIG. 5 is a generally schematic view of the cuttings processing system of FIG. 1.

DETAILED DESCRIPTION OF EMBODIMENTS OF THE INVENTION

[0024] The present invention is directed to a system and method for treating hydrocarbon containing drilling fluids and cuttings which result from drilling oil and/or gas wells using drilling fluids using a spin flash dryer system. In particular, the invention relates to on-shore and/or off-shore cleaning of cuttings containing hydrocarbons such as oil from oil-based muds. The system allows for the heating of the cuttings in a spin flash drying chamber with a closed loop atmosphere of superheated vapors, produced from steam and the evaporation of organic and volatile materials from the cuttings.

[0025] A spin flash drying chamber generally consists of a vertical cylinder that has an inverted conical bottom. Extending from the bottom of the cone, into the cylinder, is usually an axially mounted rotor or agitator. The superheated gas supplied by the heater enters the spin flash dryer through a hot inlet plenum tangentially. The tangential inlet, in conjunction with the action of the rotor or agitator, causes a turbulent whirling gas or vapor flow in the drying chamber.

[0026] According to the present invention, as cuttings and associated fluids are fed into the dryer, they form a balanced fluidized bed which is kept in motion by the dryer rotor and the tangentially entering gas or vapor. As particles have their associated hydrocarbons and water driven off, the driest and, therefore, lightest particles rise up the walls of the drying chamber. At the top of the chamber, these particles pass out of the chamber with the moving vapor or gas and enter the solids removal system. The solids removal system, usually consisting of one or more cyclones and a bag collector for filtering fines, removes the particulates and some or all of the vapor or gas is returned to the heater. A portion of the vapor may be directed to a condensing unit to eliminate water and hydrocarbons from the vapor.

[0027] Turning now to the drawings, there is shown in FIGS. 1-4 an illustrative cuttings processing system 20 for treating cuttings which contain hydrocarbons and which, when heated, are volatilized to hydrocarbon gases. The hydrocarbon gases or vapors can be very useful in providing fuel to run the system. The processing system 20 can include a feed vat 32, a spin flash drying chamber 34, a fan 36, a solids removal system 38, a heater 40, a collection system 42, a control panel 44, and a container system 46.

[0028] Referring to FIG. 5, the spin flash drying chamber 34, the solids removal system 38, the fan 36, and the heater 40 form a substantially closed loop 50 for the circulation of the vapor.

[0029] The spin flash drying chamber 34 is configured to receive the cuttings. As the cuttings are dried, the volatile hydrocarbons and water are vaporized. The drying chamber 34 is connected to the solids removal system 38 to remove the dried solids from the vapor as it exits the spin flash drying chamber 34. Some or all of the filtered vapor is recycled to the heater 40. The heater 40 heats the filtered vapor into the superheated region. The drying chamber 34 is connected to the heater 40 to receive the superheated and filtered vapor therefrom which is driven to promote the emitting of further vapor from the cuttings. The fan 36 is disposed between the solids removal system 38 and the heater 40, and is connected thereto, to form the substantially closed loop 50 and to assist in the circulation of the vapor within the loop 50.

[0030] The feed vat 32 is preferably provided for storing cuttings and feeding the cuttings to the spin flash drying chamber 34. The feed vat 32 is preferably connected to the drying chamber 34 via a conveying device 60 to permit easy transfer of the cuttings. Preferably, the feed vat 32 is provided with a vertical axis agitator 62 to facilitate the consistent feed of cuttings to the conveying device 60. In some embodiments, the feed vat 32 can include a separate tank for use with the pump.

[0031] The feed vat conveying device 60 varies depending on the consistency of the cuttings. When cuttings are of a fluid consistency, the conveying device can be simple pipe connections controlled by a valve 64 adjacent to the drying chamber 34. Other suitable valves can be provided between the feed vat 32 and the drying chamber 34. Preferably, the feed vat 32 includes as a conveying device a pump 66, such as a feed screw, lobe pump or plunger pump, for example, for positively transporting the cuttings from the feed vat 32 to the spin flash drying chamber 34. The feed vat 32 can have a conical or flat bottom and be mounted directly above a pump inlet 68.

[0032] The feed rate of cuttings into the drying chamber 34 can be controlled and regulated to maintain a predetermined dryer outlet temperature. The outlet temperature can be in the range of about 300° F to about 650° F depending on the type of oil or other hydrocarbon used in the original drilling mud and the desired final level of residual hydrocarbons remaining on the processed cuttings, for example. The feed vat 32 can be mounted on a platform scale, for example, to indicate feed rate. The feed vat weight can be continuously monitored and used to determine the feed rate.

[0033] One arrangement of the feed vat 32 is best shown in FIGS. 1 and 2. The feed vat 32 is disposed adjacent to the drying chamber 34. The feed vat 32 is disposed in a first frame 70 of the container system 46.

[0034] Referring to FIG. 5, the spin flash drying chamber 34 is configured to receive the hydrocarbon-containing cuttings. One suitable spin flash drying chamber is the dryer marketed by Invensys / APV under the brand name Anhydro Spin Flash Dryer. A water-cooled feed port 80, with a 1-½ inch diameter, for example, can be provided for receiving cuttings from the feed vat 32 therethrough. The spin flash drying chamber 34 can be in the form of a vertical cylindrical vessel which includes a rotor or agitator 82 rotatable about a vertical axis 84 of the drying chamber 34 to assist in promoting drying of the solids and vaporization of the hydrocarbons.

[0035] The drying chamber 34 is preferably connected to the solids removal system 38 to convey the vapor and dried particulates thereto. After the particulates are removed by the solids removal system 38, some or all of the filtered vapor is returned to the heater 40.

[0036] One arrangement of the drying chamber 34 is best shown in FIGS. 1 and 2. The drying chamber is disposed adjacent to the feed vat 32 and the heater 40. The drying chamber is disposed in a second frame 86 of the container system 46.

[0037] Referring to FIG. 5, the solids removal system 38 is preferably configured to remove particulates from the vapor to provide filtered vapor. The solids removal system 38 is preferably operably engaged such that the fan 36 circulates the vapor and dried particulates to the solids removal system 38.

[0038] The solids removal system 38 preferably includes at least one cyclone collection device and, more preferably, a pair of cyclone collection devices 90, 91. The cyclones 90, 91 are preferably connected in parallel to the drying chamber 34. Each cyclone 90, 91 can include a flange seal at the top thereof. Suitable cyclones include those marketed by Invensys / APV under the brand name Anhydro Cyclones and are commonly designated by cylindrical diameter. Most of the dried particulates will be removed by the cyclones 90, 91. The particulates can then be discharged for disposal or alternative use.

[0039] The solids removal system 38 also preferably includes a fines filter 94 for removing fines from the vapor. The fines filter 94 preferably has a mesh rating of about 5,000 or more such that generally particles as small as two microns or less are removed from the vapor by the filtration system. The fines filter 94 is preferably connected to the cyclones 90, 91 such that the fines filter 94 filters the vapor after the vapor has been processed by the cyclones 90, 91. The fines filter 94 preferably is a high temperature filter such as a "baghouse" filter, which can receive glass bags operable up to about 650°F, for example. Preferably, the fines filter is an Aeropulse Baghouse of cylindrical design with a high-side inlet.

[0040] Collected dust can be removed from the fines filter by a timed back-pulse of high-pressure steam or steam and emitted vapor combination. The back-pulsing can be

accomplished using saturated high-pressure steam and/or filtered vapor produced by the system heater and compressed and piped appropriately.

[0041] One arrangement of the solids removal system 38 is best shown in FIGS. 1 and 4. The cyclones 90, 91 and the fines filter 94 are disposed adjacent to each other in a third frame 96 of the container system 46.

[0042] Referring to FIG. 5, the fan 36 is preferably located between the solids removal system 38 and the heater 40 and is configured to circulate the vapor within the system. The fan 36 can be mounted in a housing 100, as shown in FIG. 1. Preferably, the fan 36 is fitted with a suitable motor 102, a 20-200 hp motor with an associated inverter, for example, to allow for fan operation at 40-80 Hz and 15-150 amps. In some embodiments, the fan motor can be mounted on the skid deck adjacent to the fan, for example. One arrangement of the fan 36 is best shown in FIGS. 1 and 2. The fan 36 is disposed above the drying chamber 34 in the second frame 86 of the container system 46.

[0043] Referring to FIG. 5, in one embodiment, the pressure within the system can be measured at an inlet 104 of the fan 36, which can be the point of lowest pressure within the loop 50. The system pressure is preferably maintained at a positive pressure relative to atmospheric pressure to avoid ingress of any air into the cuttings processing system 20. Air leakage into the cuttings processing system 20 could result in an explosion and serious injury to personnel in the vicinity. Preferably, the fan 36 is a High Pressure Blower brand fan marketed by New York Blower.

[0044] The heater 40 is further preferably provided for heating, initially water or steam, and then the filtered vapor and steam into the superheated region. The heater 40 is preferably associated with the solids removal system 38 to receive the filtered vapor therefrom. One or more dust removal cones can be disposed downstream of the heater 40 to guard against any particulates that pass through the solids removal system 38.

[0045] The heater 40 preferably indirectly heats water, steam, and/or the filtered vapor. The heater 40 preferably includes a flue-gas re-circulation system 120. The heater 40 can include a multi-pass heat exchanger, a fan assembly 122, and a burner 124. Combustion products from the discharge side of the multi-pass heat exchanger can be drawn through the fan assembly 122 and discharged adjacent the burner 124 where they are re-heated by direct mixing with the fresh combustion products. The burner 124 can be fired by gas or oil fuel, for example.

[0046] Heater fuel is preferably burned at close to stoichiometric conditions. The resulting flue gas has a very low oxygen content (typically less than about 2.0%) and can be cooled and compressed for use as an inert gas by adjacent process users or during start-up and cool-down of the cuttings processing system 20 of the present invention. Because the inlet filtered vapors entering the heater 40 are already at the outlet temperature of the drying

chamber 34, the heat input from the heater 40 is reduced, thereby further reducing the operating cost of the overall process. A suitable heater is the Indirect Fired Air Heater brand heater marketed by Stelter & Brinck Inc.

[0047] The superheated steam and/or recycled vapor is piped to the drying chamber 34 inlet plenum to convey the superheated and filtered vapor thereto to promote the emitting of the vapor from the cuttings being processed in the drying chamber 34. A drying chamber inlet temperature can determine the overall capacity of the processing system and can be maintained by modulation of the burner associated with the heater. The drying chamber inlet temperature may generally be in the range of about 400° F-1100° F depending on the metallurgy of the heater and the degradation characteristics of the oil, for example.

[0048] One arrangement of the heater 40 is best shown in FIGS. 1 and 4. The heater 40 is disposed in a fourth frame 130 of the container system 46.

[0049] Referring to FIG. 5, the collection system 42 is also preferably included in the system of the present invention. The collection system 42 receives at least a portion of the vapor exiting the solids removal system 38. These vapors include the dryer inlet vapor and the volatilized hydrocarbons and water from the cuttings. Some or all of the combined vapors are bled off the recirculating system at a point between the solids removal system 38 and the fan 36 and sent to the collection system 42, thereby reducing the size and power requirements of the fan 36.

[0050] The collection system 42 preferably includes a condenser 140 for condensing the vapor into a condensate. The condenser 140 preferably indirectly cools the vapor. The condenser 140 also preferably includes a heat exchanger 142, a pump 144, and a coolant. The pump 144 and the heat exchanger 142 are arranged to circulate the coolant through the condenser 140. The condenser 140 further preferably includes an expansion tank 145 connected to the heat exchanger 142 and the pump 144. One suitable condenser is the tubular condenser marketed by Invensys / APV under the brand Triple Tube. In one embodiment of the present invention, the condenser can be cooled by the direct spray of cooled condensate. When offshore, the condenser 140 can be cooled by sea water, for example.

[0051] The pressure within the cuttings processing system 20 can be controlled by modulation of a flow control valve system 146 located between the solids removing system 38 and the condenser 140, and most preferably between the fines filter 94 and the condenser 140. Preferably, the control valve system 146 includes a suitable control mechanism for each filter element 147, also called a "sock," of the fines filter 94, which can have one or a plurality of such filter elements 147. In the illustrative embodiment, the control mechanism includes a pair of valves 148, 149 to selectively allow vapor to move to the condenser 140 and to allow steam to move to the fines filter 94. The flow control valve system 146 can

include any suitable valve, such as a 3-way ball valve or a modulating valve to allow for independent control of the system operating pressure. The pressure within the processing system can also be controlled by modulation of the feed rate and the purge steam.

[0052] The recovered condensate is a mixture of the liquids present in the initial cuttings. Often, in the condensing process, the condensate includes at least a portion of oil and at least a portion of water. Where the condensate includes water, a separation step preferably involves separating the oil from the water.

[0053] The collection system 42 therefore also preferably includes a decanter 150. The decanter 150 is preferably arranged with the condenser 140 to receive the condensate therefrom. The liquids can separate under gravity into an upper oil layer and a lower water layer in the decanter 150 which acts as a quiescent receiving vessel. The decanter 150 includes a lower portion 152 for isolating water and a mid portion 154 for isolating liquid hydrocarbons. The decanter 150 also preferably includes a sight glass 156 which can extend between an upper portion 157 and the lower portion 152 thereof to identify the hydrocarbon-water interface. The decanter 150 also preferably includes an interface level control 158. The decanter can have a 25-300 gallon capacity, for example.

[0054] The collection system 42 further preferably includes a first pump 160 and a second pump 161, the first and second pumps 160, 161 being connected to the decanter 150. The first pump 160 is preferably a centrifugal pump which is disposed to pump hydrocarbon condensate from the mid portion 154 of the decanter. The hydrocarbon condensate, such as oil, can be conveyed by the first pump 160 via the upper port of the decanter 150 to a storage tank. Depending on its final quality, the oil can be re-used in mud, as fuel in the superheater burner, or for power generation by oil-fired engines, for example. The second pump 161 is preferably a centrifugal pump that is disposed to pump condensate (water) from the lower portion 152 of the decanter. The water can be conveyed by the second pump 161 via the lower port of the decanter 150. The water can be cooled indirectly and used for direct spray quenching in a spray condenser or discharged to a final water treatment system, for example. The first and second pumps 160, 161 are preferably suitable for atmospheric or vacuum operation. The rate of oil and water removal from the decanter 150 is preferably controlled to maintain an interface between the oil and the water layers which is substantially at the midpoint of the decanter.

[0055] Any fines passing through the fines filter, in the event of a filter failure, for example, can settle in a layer between the oil and the water to define a sludge layer. This sludge layer can be pumped to a separate filtration system via a third port at the midpoint of the receiver using a sludge pump.

[0056] One arrangement of the collection system 42 is best shown in FIGS. 1 and 2. The condenser 140 and the decanter 150 are both disposed in the first frame 70 of the

container system 46. Other components of the collection system 42 can be disposed outside of the container system 46.

[0057] Referring to FIG. 5, the cuttings processing system 20 also preferably includes a plurality of valve points, some of which are indicated with the letter *A* in FIG. 5, which are preferably accomplished by a pair of tilting disc valves mounted in series with a residence chamber therebetween, such as a "Gemco Valve," for example. Such valves can permit tight shut-off, operate at up to about 800°F, and resist seat blockage by any oversized material carry-over. The cuttings processing system 20 shown in FIG. 5 can include other valves and valve assemblies. In other embodiments, butterfly valves can be used in lieu of tilting disc valves.

[0058] Referring to FIG. 1, the control panel 44 is also preferably included and is configured to operate the cuttings processing system 20. The system 20 can be controlled by the control panel 44 to provide safe operation under a range of conditions, reduce the need for operator monitoring of the system 20, and improve the efficiency of the system 20.

[0059] Preferably, the control panel 44 can continuously collect desired process data, including pressures, temperatures, motor loads, feed rate, and product collection rates. For example, the control panel 44 can preferably provide safe automatic operation and complete recording capability for: (1) the fan inlet and outlet pressures, the heater outlet pressure, the drying chamber outlet pressure, the fines filter pressure, and the condenser pressure; (2) the drying chamber inlet and outlet temperatures, the fan inlet temperature, the powder discharge temperature, the flue gas temperature, the temperature of the vapor at the condenser inlet, the temperature of the condensate discharge, and the condenser cooling water outlet temperature; (3) the fan motor load, the drying chamber agitator motor load, the conveying device pump motor load, and the feed vat agitator motor load; (4) the fan motor frequency, the drying chamber agitator motor frequency, the conveying device pump motor frequency, and the feed vat agitator motor frequency; (5) the feed rate from the conveying device; (6) the powder rate; (7) the hydrocarbon (oil) recovery rate; and (8) the water recovery rate.

[0060] Preferably, the cuttings processing system 20 is packaged within a container system 46 suitable for transportation, especially to offshore oil drilling rigs and platforms. Preferably, the components of the cuttings process system are disposed within the container system 46, each frame weighing no more than about 15,000 pounds. Such a containerized system can be more readily handled by available crane systems. It will be understood that in some embodiments, at least one component of the cuttings processing system 20 can be housed outside of the container system 46.

[0061] Referring to FIG. 5, in operation, the process of the present invention involves treating cuttings or other solids which includes hydrocarbons such as oil and which may

also contain water. The hydrocarbons and water can be vaporized at temperatures at or below about 500° F (260° C). A supply of such cuttings are conveyed to the spin flash drying chamber 34. Preferably, the cuttings are supplied from the feed vat 32. Super heated vapors are then supplied by the heater 40 to the spin flash drying chamber 34. Initially, a fuel supply, such as natural gas or other suitable fuel is used to fire the heater 40. Once underway, hydrocarbon vapors and/or hydrocarbon condensate condensed from the vapors produced by the spin flash dryer 34 may supplement the fuel supply to fire the heater 40. Preferably, the produced hydrocarbon and any water (steam) vapors are processed through the solids removal system 38 which preferably includes one or more cyclones and a fines filter to remove the dried particulates from the vapor and produce a filtered vapor. The heater 40 then heats the filtered vapor to a superheated region between about 500° F (260° C) and about 1100° F (594° C). The superheated vapor is then conveyed to the drying chamber 34 to complete the closed loop system. As sufficient vapors are produced, a portion of the vapors are diverted to the condenser system so that the hydrocarbons can be collected as fluids and then used to fire the heater 40 or returned to the drilling mud system.

[0062] The cuttings processing system 20 can clean cuttings produced while using an oil-based mud to an acceptable residual hydrocarbons level.

[0063] In one embodiment, a process according to the present invention can be used to treat hydrocarbon cuttings containing vapor. The process can include storing the mud cuttings in a feed vat 32 which is connected to a spin flash drying chamber 34. The mud cuttings can be conveyed from the feed vat 32 to the drying chamber 34. The mud cuttings can be dried in the drying chamber 34 to promote the production of the vapor. The vapor can be filtered to remove particulates therefrom, preferably including removing fines from the vapor. The vapor can be heated, preferably by indirect heating, into a superheated region. The superheated vapor can be conveyed to the drying chamber 34 to form a closed loop 50. At least a portion of the vapor can be condensed to form a condensate which can include at least a portion of oil and at least a portion of water. The condensate can be collected in a collection system 42. The oil and the water of the condensate can be separated for further treatment and/or re-use.

[0064] The cuttings processing system 20 of the present invention, which includes the steam atmosphere spin flash drying chamber 34 is able to process cuttings in an inert atmosphere, thereby reducing the risk of fire. Because the heater 40 need only heat the vapor from the dryer outlet temperature back up to the desired dryer inlet temperature, lower operating costs can be achieved.

[0065] The spin flash drying chamber can produce exhaust vapor as a byproduct at a rate equal to the evaporation in the dryer. The exhaust vapor can be of suitable quality for

use in heating process air or water – either by using heat exchangers or by direct sparging, for example.

[0066] The spin flash drying chamber does not produce gaseous emissions, thereby reducing any adverse impact upon the environment and any potential odor problems.

[0067] The spin flash drying chamber can eliminate the need for external product back-mixing, which is an inherently messy and dusty operation that can require additional equipment, power, and labor.

[0068] Oil-based cuttings can be successfully processed by the spin flash drying chamber in a superheated atmosphere comprising steam plus vapors of the hydrocarbons removed from the cuttings. The use of the present system can allow for processing of the cuttings with an acceptable residual level of hydrocarbons at reduced operating temperatures. Reduced levels of residuals can be possible by increasing the operating temperatures and by the addition of steam to the system.

[0069] The processing system can also be used for removing volatile hydrocarbons such as solvents from solvent wet cakes or sludges. Typical applications for solvent removal arise after the use of hexane, for example, to remove oil from cellular materials such as soybeans or in other chemical processes after the bulk of the solids are removed from waste water streams, or after the cleaning of tanks in a hydrocarbon tank farm.

[0070] All references, including publications, patent applications, and patents, cited herein are hereby incorporated by reference to the same extent as if each reference were individually and specifically indicated to be incorporated by reference and were set forth in its entirety herein.

[0071] The use of the terms "a" and "an" and "the" and similar referents in the context of describing the invention (especially in the context of the following claims) are to be construed to cover both the singular and the plural, unless otherwise indicated herein or clearly contradicted by context. Recitation of ranges of values herein are merely intended to serve as a shorthand method of referring individually to each separate value falling within the range, unless otherwise indicated herein, and each separate value is incorporated into the specification as if it were individually recited herein. All methods described herein can be performed in any suitable order unless otherwise indicated herein or otherwise clearly contradicted by context. The use of any and all examples, or exemplary language (e.g., "such as") provided herein, is intended merely to better illuminate the invention and does not pose a limitation on the scope of the invention unless otherwise claimed. No language in the specification should be construed as indicating any non-claimed element as essential to the practice of the invention.

[0072] Preferred embodiments of this invention are described herein, including the best mode known to the inventors for carrying out the invention. Of course, variations of those

preferred embodiments would become apparent to those of ordinary skill in the art upon reading the foregoing description. The inventors expect skilled artisans to employ such variations as appropriate, and the inventors intend for the invention to be practiced otherwise than as specifically described herein. Accordingly, this invention includes all modifications and equivalents of the subject matter recited in the claims appended hereto as permitted by applicable law. Moreover, any combination of the above-described elements in all possible variations thereof is encompassed by the invention unless otherwise indicated herein or otherwise clearly contradicted by context.

What is claimed is:

1. A cuttings processing system for treating cuttings produced during the drilling of a well which contain hydrocarbons, the system comprising:
a spin flash drying chamber, the drying chamber configured to receive the cuttings.
2. The cuttings processing system according to claim 1 wherein the cuttings emit a vapor, the system further comprising:
a fan, the fan configured to circulate the vapor within the system.
3. The cuttings processing system according to claim 2 further comprising:
a solids removal system configured to remove particulates from the vapor to provide filtered vapor.
4. The cuttings processing system according to claim 3 further comprising:
a heater for heating the filtered vapor into the superheated region, the heater associated with the filter device to receive the filtered vapor therefrom.
5. The cuttings processing system according to claim 4 wherein the drying chamber is connected to the heater to receive the superheated and filtered vapor therefrom and the drying chamber is connected to the solids removal system to convey the vapor thereto.
6. The cuttings processing system according to claim 5 further comprising:
a feed vat for storing cuttings, the feed vat connected to the drying chambers, via a conveying device for transporting the cuttings to the drying chamber.
7. The cuttings processing system according to claim 6 wherein the conveying device includes a pump.
8. The cuttings processing system according to claim 6 wherein the feed vat includes an agitator.

9. The cuttings processing system according to claim 5 further comprising:
a collection system for receiving at least a portion of the vapor, the collection system including a condenser for condensing the vapor into a condensate.

10. The cuttings processing system according to claim 9 wherein the condenser indirectly cools the vapor.

11. The cuttings processing system according to claim 10 wherein the condenser includes a heat exchanger, a pump, and a coolant, the pump and the heat exchanger arranged to circulate the coolant through the condenser.

12. The cuttings processing system according to claim 11 wherein the condenser further includes an expansion tank connected to the heat exchanger and the pump.

13. The cuttings processing system according to claim 9 wherein the collection system includes a decanter, which receives condensate from the condenser.

14. The cuttings processing system according to claim 13 wherein the decanter includes a lower portion and an upper portion, and the collection system further includes a first pump and a second pump, the first and second pumps being connected to the decanter, the first pump disposed to pump condensate from the upper portion of the decanter, and the second pump disposed to pump condensate from the lower portion of the decanter.

15. The cuttings processing system according to claim 5 further comprising:
a control panel configured to operate the system.

16. The cuttings processing system according to claim 5 further comprising:
a container for housing the fan, the solids removal system, the heater, and the spin flash drying chamber.

17. The cuttings processing system according to claim 5 wherein the solids removal system includes at least one cyclone collection device.

18. The cuttings processing system according to claim 17 wherein the at least one cyclone is two cyclones connected in parallel to the drying chamber.

19. The cuttings processing system according to claim 17 wherein the solids removal system includes a fines filter for removing fines from the vapor.

20. The cuttings processing system according to claim 18 wherein the solids removal system includes a fines filter for removing fines from the vapor, the fines filter being connected to the outlet of the at least one cyclone.

21. The cuttings processing system according to claim 5 wherein the heater indirectly heats the vapor.

22. The cuttings processing system according to claim 22 wherein the heater includes a flue-gas re-circulation system.

23. The cuttings processing system according to claim 22 wherein the heater includes a fan and a burner.

24. The cuttings processing system according to claim 5 wherein the spin flash drying chamber includes an agitator.

25. A process for treating oil-based cuttings which emit vapor, the process comprising:

drying the cuttings in a spin flash drying chamber to vaporize the hydrocarbons associated with the cuttings.

26. The process according to claim 25 further comprising:
removing the dried particulates from the vapor.

27. The process according to claim 26 wherein the removal step includes removing fines from the vapor.

28. The process according to claim 26 further comprising:
conveying superheated vapor to the spin flash drying chamber.
29. The process according to claim 28 further comprising:
storing the cuttings in a feed vat connected to the drying chamber; and
conveying the cuttings from the feed vat to the drying chamber.
30. The process according to claim 29 further comprising:
condensing at least a portion of the vapor to form a condensate.
31. The process according to claim 30 wherein the condensing step includes
indirectly cooling the vapor.
32. The process according to claim 30 wherein the condensate includes at least a
portion of hydrocarbons and at least a portion of water, the process further comprising:
collecting the condensate; and
separating the hydrocarbons from the water.
33. A system for processing cuttings produced during the drilling of a well using
a hydrocarbon containing drilling fluid, the system comprising:
a heater for producing superheated vapors;
a spin flash drying chamber for removing any hydrocarbons or water from
the cuttings;
a solids removal system for separating the dried cuttings particles from the
vapor; and
a collection system for isolating and separating the hydrocarbons from the
vapor.
34. The system of claim 33, wherein the solids removal system includes one or
more cyclones.
35. The system of claim 33, wherein the collection system includes a condenser.

36. A system for processing hydrocarbon containing drilling muds, the system comprising:

a heater for producing superheated vapors;
a spin flash drying chamber for drying the solids contained in the mud to remove any hydrocarbons or water from the solids;
a solids removal system for separating the dried solids from the vapor; and
a collection system for isolating and separating the hydrocarbons from the vapor.

37. The system of claim 36, wherein the solids removal system includes one or more cyclones.

38. The system of claim 36, wherein the collection system includes a condenser.

39. A method of processing hydrocarbon-containing cuttings produced during the drilling of a well using a hydrocarbon-containing drilling fluid, the method comprising:
feeding the cuttings to a spin flash drying chamber;
feeding superheated steam to the drying chamber to vaporize hydrocarbons contained in or on the cuttings and to dry the solids contained in the cuttings;
feeding the vaporized hydrocarbons and dried solids to a solids removal system to isolate the dried solids from the vapor;
feeding at least a part of the vapor to a collection system to collect the hydrocarbons contained in the vapor; and
feeding at least a part of the vapor to the heater to be superheated for return to the spin flash drying chamber.

40. The method of claim 39, wherein solids are removed from the vapor using one or more cyclones.

41. The method of claim 39, wherein the hydrocarbons are removed from the vapor using a condenser contained in the collection system.

42. A method of processing hydrocarbon containing drilling muds, the method comprising:

feeding drilling mud to a spin flash drying chamber;

feeding superheated steam to the drying chamber to vaporize hydrocarbons contained in or on the drilling mud and to dry the solids contained in the drilling mud;

feeding the vaporized hydrocarbons and dried solids to a solids removal system to isolate the dried solids from the vapor;

feeding at least a part of the vapor to a collection system to collect the hydrocarbons contained in the vapor; and

feeding at least a part of the vapor to the heater to be superheated for return to the spin flash drying chamber.

43. The method of claim 42, wherein solids are removed from the vapor using one or more cyclones.

44. The method of claim 42, wherein the hydrocarbons are removed from the vapor using a condenser contained in the collection system.

45. A system for processing volatile hydrocarbon-containing solids, the system comprising:

a heater for producing superheated vapors;

a spin flash drying chamber for drying the volatile hydrocarbon-containing solids to remove any hydrocarbons or water from the solids;

a solids removal system for separating the dried solids from the vapor; and

a collection system for isolating and separating the hydrocarbons from the vapor.

46. The system of claim 36, wherein the solids removal system includes one or more cyclones.

47. The system of claim 36, wherein the collection system includes a condenser.

48. A method of processing volatile hydrocarbon-containing solids, the method comprising:

feeding the volatile hydrocarbon-containing solids to a spin flash drying chamber;

feeding superheated steam to the drying chamber to vaporize hydrocarbons contained in or on the solids and to dry the solids contained in the cuttings;

feeding the vaporized hydrocarbons and dried solids to a solids removal system to isolate the dried solids from the vapor;

feeding at least a part of the vapor to a collection system to collect the hydrocarbons contained in the vapor; and

feeding at least a part of the vapor to the heater to be superheated for return to the spin flash drying chamber.

49. The method of claim 48, wherein solids are removed from the vapor using one or more cyclones.

50. The method of claim 48, wherein the hydrocarbons are removed from the vapor using a condenser contained in the collection system.

51. A cuttings processing system for treating cuttings produced during the drilling of a well which contain hydrocarbons, the system comprising:

a spin flash drying chamber, the drying chamber configured to receive the cuttings; and

a container system for substantially housing the processing system, the container system including at least one frame.

52. The system of claim 51, wherein each frame of the containerized system has a total weight of about 15,000 pounds or less.

FIG. 1

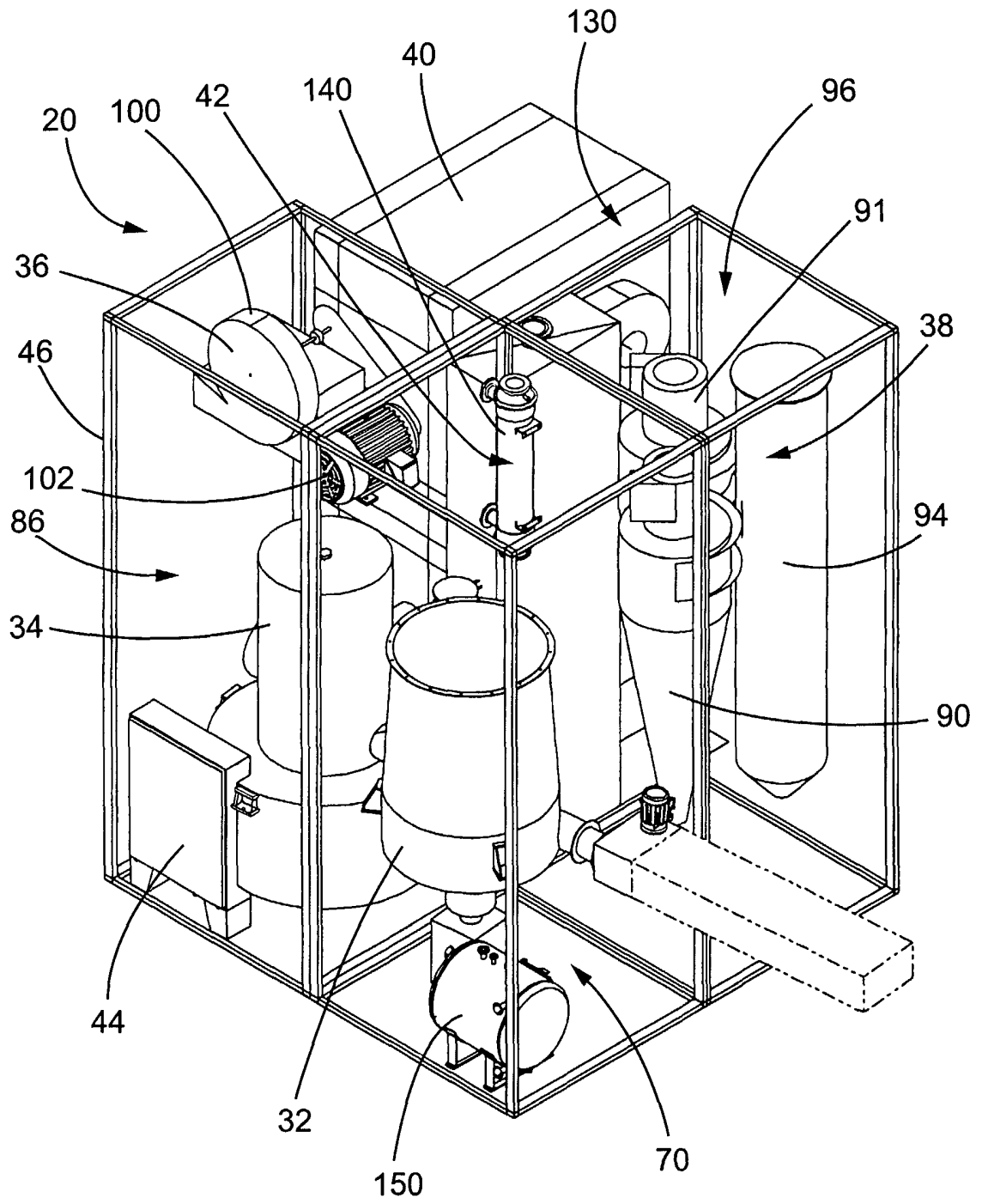

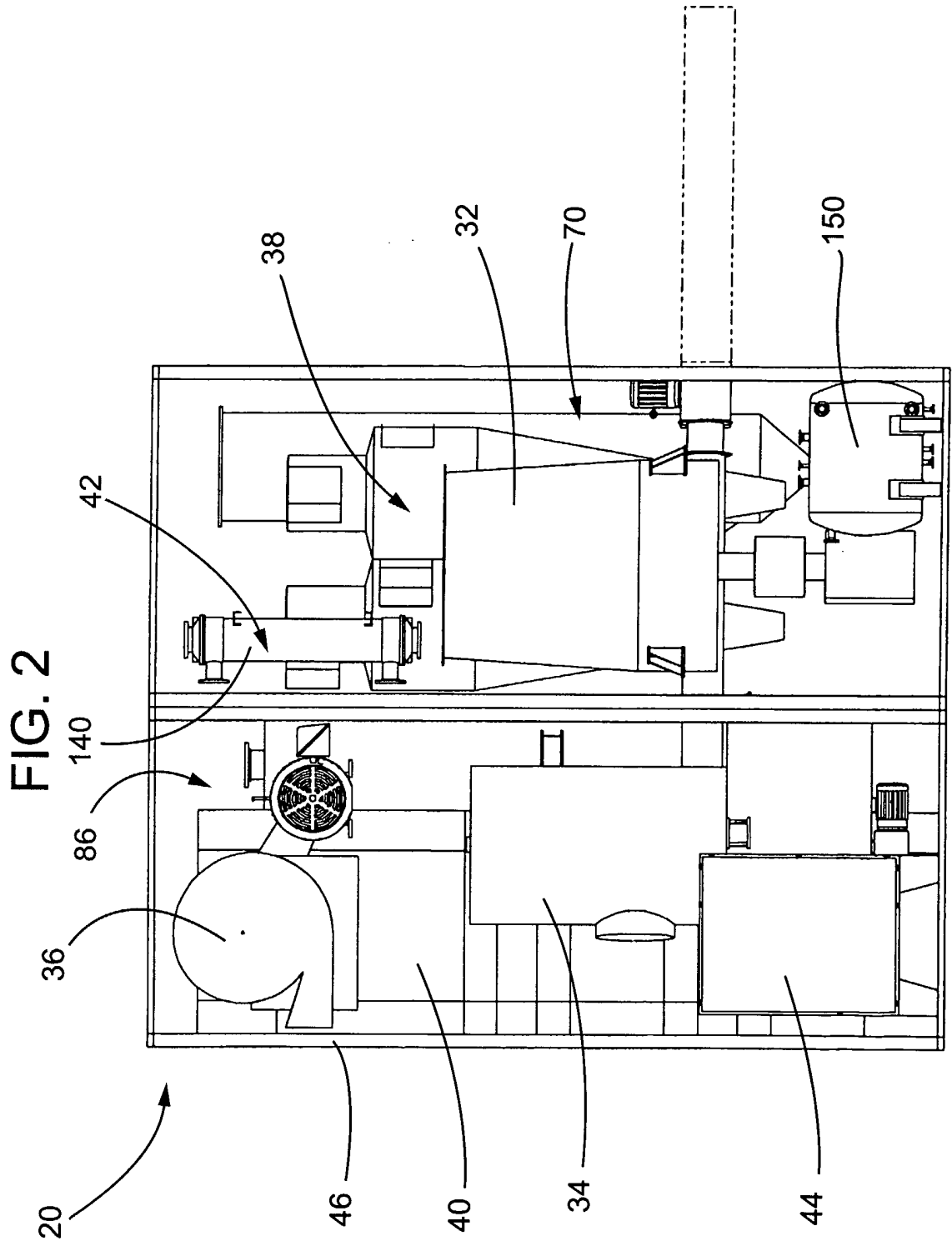
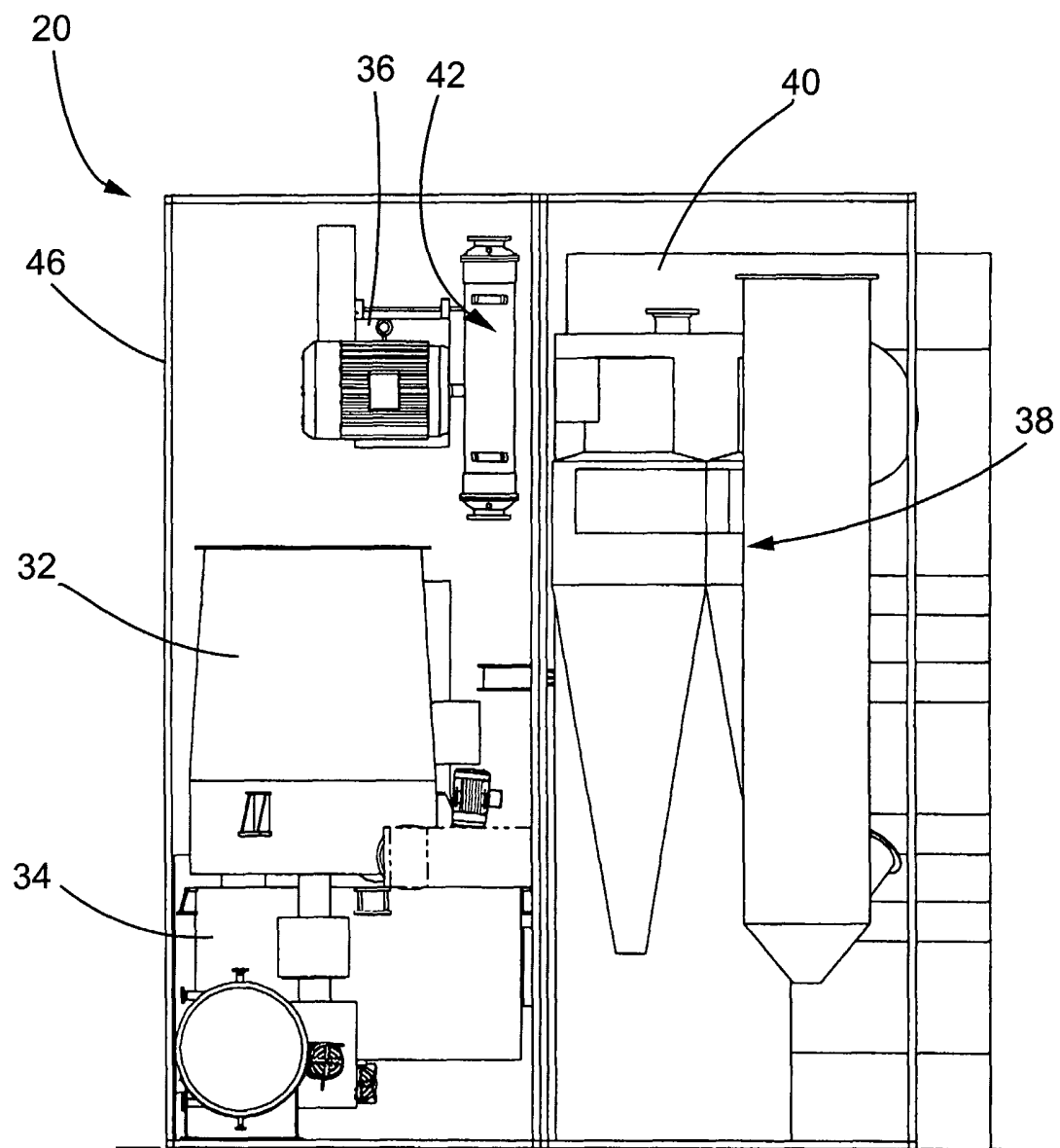
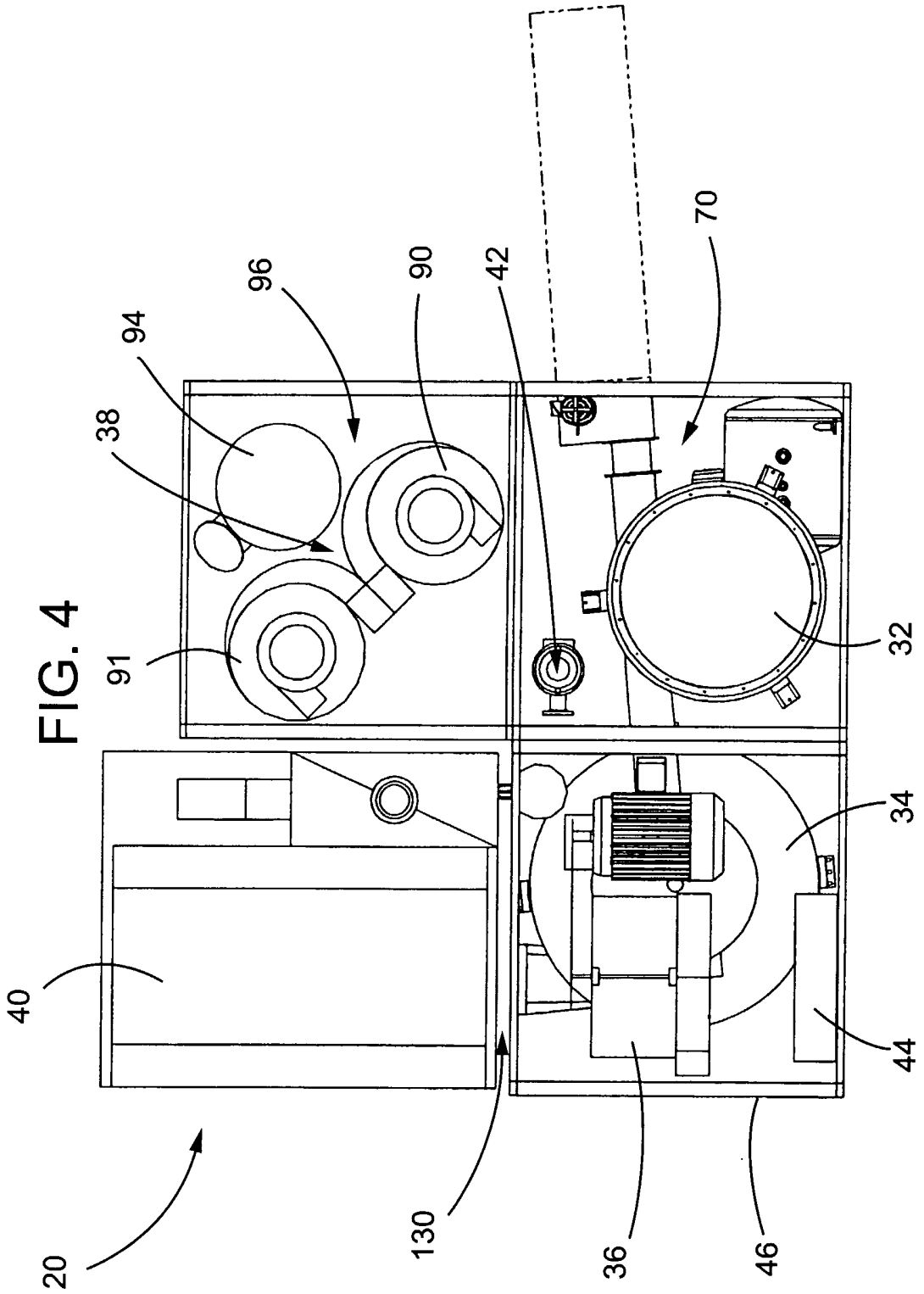

FIG. 3





INTERNATIONAL SEARCH REPORT

International Application No
PCT/US 02/27266

A. CLASSIFICATION OF SUBJECT MATTER IPC 7 E21B21/06		
According to International Patent Classification (IPC) or to both national classification and IPC		
B. FIELDS SEARCHED		
Minimum documentation searched (classification system followed by classification symbols) IPC 7 E21B		
Documentation searched other than minimum documentation to the extent that such documents are included in the fields searched		
Electronic data base consulted during the international search (name of data base and, where practical, search terms used) EPO-Internal		
C. DOCUMENTS CONSIDERED TO BE RELEVANT		
Category ^o	Citation of document, with indication, where appropriate, of the relevant passages	Relevant to claim No.
A	US 5 291 668 A (BECKER FREDERICK E ET AL) 8 March 1994 (1994-03-08) figure 17	1,25,33, 36,39, 42,45, 48,51
A	--- US 6 085 440 A (GETLER JENS) 11 July 2000 (2000-07-11) abstract column 1, line 19 - line 21; figure 1 --- -/--	1,25,33, 36,39, 42,45, 48,51
<input checked="" type="checkbox"/> Further documents are listed in the continuation of box C.		
<input checked="" type="checkbox"/> Patent family members are listed in annex.		
^o Special categories of cited documents :		
A document defining the general state of the art which is not considered to be of particular relevance *E* earlier document but published on or after the international filing date *L* document which may throw doubts on priority claim(s) or which is cited to establish the publication date of another citation or other special reason (as specified) *O* document referring to an oral disclosure, use, exhibition or other means *P* document published prior to the international filing date but later than the priority date claimed		
T later document published after the international filing date or priority date and not in conflict with the application but cited to understand the principle or theory underlying the invention *X* document of particular relevance; the claimed invention cannot be considered novel or cannot be considered to involve an inventive step when the document is taken alone *Y* document of particular relevance; the claimed invention cannot be considered to involve an inventive step when the document is combined with one or more other such documents, such combination being obvious to a person skilled in the art. *&* document member of the same patent family		
Date of the actual completion of the international search 23 October 2002		Date of mailing of the international search report 06/11/2002
Name and mailing address of the ISA European Patent Office, P.B. 5818 Patentlaan 2 NL - 2280 HV Rijswijk Tel. (+31-70) 340-2040, Tx. 31 651 epo nl, Fax: (+31-70) 340-3016		Authorized officer Bellingacci, F

INTERNATIONAL SEARCH REPORT

International Application No
PCT/US 02/27266

C.(Continuation) DOCUMENTS CONSIDERED TO BE RELEVANT		
Category *	Citation of document, with indication, where appropriate, of the relevant passages	Relevant to claim No.
A	<p>US 4 313 785 A (SCHELLSTEDE HERMAN J) 2 February 1982 (1982-02-02)</p> <p>column 3, line 1 - line 15; claim 1; figure 2</p> <p style="text-align: center;">---</p>	<p>1, 25, 33, 36, 39, 42, 45, 48, 51</p>
P, X	<p>US 2001/039887 A1 (REDDOCH JEFFREY) 15 November 2001 (2001-11-15)</p> <p>abstract paragraph '0043!</p> <p style="text-align: center;">-----</p>	<p>1, 25, 33, 36, 39, 42, 45, 48, 51</p>

INTERNATIONAL SEARCH REPORT
Information on patent family members

International Application No
PCT/US 02/27266

Patent document cited in search report		Publication date	Patent family member(s)	Publication date
US 5291668	A	08-03-1994	NONE	
US 6085440	A	11-07-2000	DE 69603288 D1 DE 69603288 T2 WO 9719307 A1 EP 0862718 A1 DK 862718 T3	19-08-1999 09-12-1999 29-05-1997 09-09-1998 29-11-1999
US 4313785	A	02-02-1982	NONE	
US 2001039887	A1	15-11-2001	US 6279471 B1	28-08-2001