

(19) **DANMARK**

(10) **DK/EP 3299633 T3**



Patent- og
Varemærkestyrelsen

(12) **Oversættelse af
europæisk patentskrift**

-
- (51) Int.Cl.: **F 04 D 29/42 (2006.01)** **F 04 D 29/60 (2006.01)** **F 04 D 29/62 (2006.01)**
F 04 D 13/06 (2006.01)
- (45) Oversættelsen bekendtgjort den: **2023-03-13**
- (80) Dato for Den Europæiske Patentmyndigheds bekendtgørelse om meddelelse af patentet: **2022-12-28**
- (86) Europæisk ansøgning nr.: **16190681.3**
- (86) Europæisk indleveringsdag: **2016-09-26**
- (87) Den europæiske ansøgnings publiceringsdag: **2018-03-28**
- (84) Designerede stater: **AL AT BE BG CH CY CZ DE DK EE ES FI FR GB GR HR HU IE IS IT LI LT LU LV MC MK MT NL NO PL PT RO RS SE SI SK SM TR**
- (73) Patenthaver: **Robert Bosch GmbH, Postfach 30 02 20, 70442 Stuttgart, Tyskland**
- (72) Opfinder: **Bedin, Dario, Via Capo di Sopra, 7, 36063 Marostica, Italien**
Mondin, Roberto, Via S. Luca, 13, 31038 Paese, Italien
Melison, Marco, Strada del Tormeno, 22, 36100 Vicenza, Italien
Daglioz, Ozkan, 25/2 street no:7, door:25, 45410 Gaziemir/Izmir, Tyrkiet
Pekguzelsu, Mustafa, Manavkuyu Mh. 275/6 Sok , No:6 D8, 35030 Bayakri/ Izmir, Tyrkiet
Onal, Yasar, 6753/8 sok. No:15/C, D:18, K:8 , Varyant Sitesi Karsiyaka, 35570 Izmir, Tyrkiet
Erdogan, Hasan Cosan, Kazim Dirik Mahallesi , 162. Sokak Park Apt No: 36/3, 35100 Bornova/Izmir, Tyrkiet
Konuk, Gokhan, Evka-3 Mah. 126/10, Sokak Oezkanlar Sitesi No:8 Daire 11, 35030 Bornova/ Izmir, Tyrkiet
Kirgiz, Saim, Erzene Mahallesi, 113/6 sokak, No.9 D.14, 35030 Bornova/Izmir, Tyrkiet
- (74) Fuldmægtig i Danmark: **Budde Schou A/S, Dronningens Tværgade 30, 1302 København K, Danmark**
- (54) Benævnelse: **Cirkulationspumpesystem**
- (56) Fremdragne publikationer:
WO-A1-2011/035985
WO-A1-2014/195001
US-A1- 2009 267 344
US-A1- 2015 063 987

DESCRIPTION

Field of the invention

[0001] The present invention relates to a hydraulic connector.

[0002] The present invention further relates to a circulator pump and a pump system, which comprises a circulator pump and a hydraulic connector.

[0003] In particular, the present invention is directed to a circulator pump system which may be employed in hydronic systems, including both heating and cooling piping systems. The present invention is particularly suitable for application in the field of OEM high efficiency circulator pumps.

Background of the invention

[0004] A circulator pump is a specific type of pump used to circulate gases, liquids, or slurries in a closed circuit. Circulator pumps are commonly employed for circulating water or other fluids in a heating or cooling system, especially of buildings or the like. Circulator pumps are typically designed to provide a limited pressure head to the fluid, as they circulate the fluid only within a closed circuit, and they need to overcome only the friction of the fluid in the piping system.

[0005] Circulator pumps are usually electrically powered centrifugal pumps, having limited size and power. In certain applications, circulator pumps comprise a sealed main body having a motor rotor, a pump impeller, and support bearings combined and sealed within the water circuit. By providing sealed pump units, or "main pump bodies", it becomes easier to maintain a water-tight seal at the point where the pump drive shaft enters the volute.

[0006] Small-sized to medium-sized circulator pumps are usually supported entirely by the pipe flanges that join them to the rest of the piping.

[0007] Circulator pumps may be fitted with, or associated to, a plurality of further devices and sensors, which complement their functioning. For example, circulator pumps may be associated or provided with pressure sensors, temperature sensors, flow meters, expansion vases, purge valves, safety valves, air separators and the like.

[0008] When a circulator pump, which is installed in a piping system, needs to be disconnected for maintenance, difficulties can arise.

[0009] In fact, a circulator pump is effectively a component of the piping system which is kept

in a closed loop, under water-tight conditions. When circulator pumps with sealed bodies need to be actually removed from the piping system, in order to provide servicing, the sealing may be damaged.

[0010] In particular, removal of a circulator pump from the piping system may cause inconveniences, for example it may damage the pipe flanges which join the circulator pump to the rest of the piping.

[0011] Furthermore, removal of a circulator pump from the piping system may be troubled by interference of the additional devices attached to the pump, such as sensors associated to the circulator pump, which hinder easy access to the pipe flanges. Since pipe flanges for connection of the circulator pump are often extremely close to the wall, installation and removal of a circulator pump according to the prior art may become cumbersome.

[0012] Additionally, after maintenance, servicing and/or inspection of the circulator pump are completed, if the connection to the pipe flanges is not accurately restored, the water-tight seal of the piping system may be comprised, leading to leakage of fluid.

[0013] A known hydraulic connector and circulator pump are described in WO2014/195001 A1.

[0014] It is an objective of the present invention to solve drawbacks of the prior art. In particular, it is an object of the present invention to provide a circulator pump which is improved with respect to the prior art.

[0015] It is a further object of the present invention to simplify the disconnection of a circulator pump from its piping system, to simplify maintenance thereof.

[0016] It is a further object of the present invention to prevent damaging seals of circulator pump systems, whenever these are disconnected and removed from the piping system, so as to assure water-tight conditions in the circuit.

[0017] It is a further object of the present invention to provide circulator pump systems which are connected to a piping system in a more convenient and effective manner.

[0018] It is a further object of the present invention to simplify mounting of a circulator pump on a piping system, and removal thereof, even when additional devices are meant to be attached to the circulator pump.

[0019] It is a further object of the present invention to prevent leakage of fluid in a piping system comprising a circulator pump system.

Summary of the Invention

[0020] These and other objects of the present invention are achieved by a hydraulic connector and a pump system which incorporate the features set out in the appended claims, which are an integral part of the present description.

[0021] The present invention can be used with a circulator pump, having a circulator pump main body to be mounted on a piping system and which comprises: an impeller; an electric motor for rotating the impeller; a volute defining a volute chamber for housing the impeller; the volute has a central inlet hole for coupling the circulator pump in a releasable manner to a hydraulic connector of the piping system; the volute is further structured with a lateral discharge flange portion for coupling to an outlet portion of the piping system.

[0022] According to a preferred embodiment, the circulator pump has a circulator pump main body which comprises: an impeller; an electric motor for rotating the impeller; a volute defining a volute chamber for housing the impeller and providing fluid-tightness in the circulator pump, for a flow of fluid passing through the impeller; a discharge flange portion provided downstream of the impeller and structured for connecting to a piping system in fluid-tight manner. The circulator pump further comprises: a volute flange portion comprising an inlet hole for the flow of fluid entering the volute; such volute flange portion is structured for connecting in a fluid-tight manner to an outlet section of a hydraulic connector, the outlet section comprising an outlet hole for the flow of a fluid; the circulator pump further comprises a mating element provided on the circulator pump main body, wherein the mating element is structured for providing a releasable coupling between the volute flange portion and the outlet section. Advantageously, such circulator pump can be releasably coupled with its volute flange portion to an outlet section of a hydraulic connector, thus simplifying the removal of the pump circulator from the piping system, for maintenance or inspection.

[0023] Advantageously the mating element is structured for providing a releasable coupling, between the volute flange portion and the outlet section, so that water-tight conditions in the circuit can be effectively restored.

[0024] Advantageously, the mating element is provided on the circulator pump main body so that mounting and removal of the circulator pump on the piping system is simplified, even if additional devices are attached to the hydraulic connector.

[0025] The present invention is particularly suitable for application in the field of OEM high efficiency circulation pumps.

[0026] The present invention provides for a hydraulic connector for a circulator pump comprising: a hollow pipe body for the flow of a fluid, the hollow pipe body comprising a suction flange portion provided at a first end of the hollow pipe body and structured for connecting to a piping system in a fluid-tight manner, the hollow pipe body further comprising an outlet section provided at a second end of the hollow pipe, the outlet section being structured for connecting to a volute flange portion of a circulator pump in a fluid-tight manner, the outlet section comprising an outlet hole for the flow of said fluid; the hydraulic connector further comprises a

connection element provided at the second end and structured for providing a releasable coupling between the outlet section and the volute flange portion; the connection element further comprising a coupling flange portion having a coupling surface structured for mating with a respective mating element of a circulator pump main body; the coupling surface being structured for engaging with at least one releasable retaining element, for coupling of the outlet section with the volute flange portion; the connection element comprises a circular shaped coupling body on said outlet section, the circular shaped coupling body being structured for engaging with a volute flange portion of a circulator pump main body; the circular shaped coupling body comprising a plurality of, preferably four, peripheral slots for receiving a releasable retaining element, the releasable retaining element being a resilient fixing clip structured for acting on the periphery of said volute flange portion.

[0027] Advantageously, additional devices or sensors may be associated directly to the hydraulic connector, without limiting access to the circulator pump, so that its removal from the piping system is not hindered.

[0028] Advantageously, the hydraulic connector comprises a connection element provided at its end which is free from the piping system, thus simplifying the removal of the circulator pump, for maintenance or inspection.

[0029] Advantageously the connection element is structured for providing a releasable coupling, between the volute flange portion and the outlet section, so that water-tight conditions in the circuit can be effectively restored.

[0030] Yet another aspect of the present invention provides for a pump system comprising: a circulator pump main body which comprises: an impeller; an electric motor for rotating the impeller; a volute defining a volute chamber for housing the impeller and providing fluid-tightness in the circulator pump for a flow of fluid passing through the impeller. The pump system further comprises: a hollow pipe body for the flow of a fluid to the impeller; a suction flange portion provided at a first end of the hollow pipe and structured for connecting to a piping system in a fluid-tight manner; an outlet section provided at a second end of the hollow pipe, the outlet section comprising an outlet hole for the flow of the fluid; a discharge flange portion provided downstream of the impeller and structured for connecting to a piping system in fluid-tight manner; a volute flange portion for the flow of the fluid entering the volute, the volute flange portion comprising an inlet hole. The outlet section and the volute flange portion are connected in a fluid-tight manner; a mating element is provided on the circulator pump main body; a connection element is provided at the second end; the mating element and the connection element are structured for respectively coupling with each other and for providing a releasable coupling between the volute flange portion and the outlet section.

[0031] According to the invention, the pump system comprises a circulator pump and a hydraulic connector, which have been already briefly illustrated above and which are releasably connectable by coupling a connection element with a mating element.

[0032] In general, an advantage of the present invention is to effectively provide a leak-free connection between a circulator pump and a hydraulic connector of a piping system.

[0033] Other features and advantages of the invention will be apparent from the following description of preferred embodiments, and from the claims.

Brief description of the Drawings

[0034] The invention will be now described with reference to the annexed drawings. Figures 6 to 8 are provided as non-limiting examples of preferred embodiments. The embodiments shown in figures 1 to 5 do not form part of the invention but represent background art that is useful for understanding the invention:

- Figure 1 is a first perspective view of a pump system, including a circulator pump and a hydraulic connector.
- Figure 2 is a section view of the pump system of Figure 1.
- Figure 3 is yet a perspective view of the pump system of Figure 1, seen from a different angle.
- Figure 4 is a partly disassembled view of the pump system of Figure 1.
- Figure 5 is a section view of the pump system of Figure 4.
- Figure 6 is a perspective view of a pump system, including a circulator pump and a hydraulic connector, according to a preferred embodiment of the present invention.
- Figure 7 is a partly disassembled view of the pump system of Figure 6.
- Figure 8 is yet another view of the pump system of Figure 7.

[0035] In the drawings referred to in the description, the same reference numerals designate the same or equivalent elements or actions.

Detailed Description of the Invention

[0036] Figure 1 shows a first perspective view of a pump system 99, including a circulator pump 100 and a hydraulic connector 101.

[0037] The circulator pump 100 comprises a pump main body 1 housing the components of the pump, which will be further described in more detail. Such pump main body 1 defines a sealed pump unit, which is typically sold as a single part.

[0038] The circulator pump 100 comprises a volute 2 of containment, which is part of the pump main body 1, and is coupled thereon. The purpose of the volute 2 is housing the impeller of the pump, as it will be further described.

[0039] The pump main body 1 further comprises, on its external surface, a plurality of connectors 3a and 3b of electrical and electronic type. These connectors 3a and 3b are configured for powering the electric motor of the circulator pump 100 and/or for controlling the operation of the same.

[0040] The circulator pump 100 is connected to a piping system by means of a hydraulic connector 101. Through the hydraulic connector 101, the working fluid reaches the circulator pump 100 for increase of the pressure head.

[0041] Figure 2 shows, in a sectional view, the main internal components of the circulator pump 100.

[0042] As mentioned, the pump main body 1 accommodates an internal electric motor 5, 6, which preferably includes a permanent magnet rotor 5 and a stator 6 with the relevant electrical windings. The stator 6 is preferably of the type with four stator arms forming a two-phase electric motor configuration.

[0043] In this preferred embodiment, the electric motor 5, 6 is of the synchronous type. The skilled in the art will understand that other configurations are also adoptable, for example by employing an asynchronous electric motor.

[0044] The pump main body 1 further comprises a shaft 7 of the electric motor which is coupled to the rotor 5. The shaft 7 is thus configured for being set into rotation by the electric motor 5, 6. In general, the circulator pump 100 includes suitable support bearings for the rotation of the shaft 7, such as for example rolling elements and thrust bearings adapted to support the forces that occur during circulation of fluid in the pump.

[0045] As mentioned, the pump main body 1 comprises an impeller 8 which is coupled on the shaft 7 and therefore is adapted to be set in rotation by the electric motor 5, 6, 7.

[0046] The impeller 8 is housed within a volute chamber 9, which is defined in the inside portion of the volute 2, which is part of the main pump body 1.

[0047] The volute chamber 9 is structured to provide fluid-tightness for the flow of fluid arriving through the hydraulic connector 101 to the impeller 8 of the circulator pump 100. To this extent, the shaft 7 passes through a wall that separates the volute chamber 9 from the housing of the motor 5, 6, 7 in the main pump body 1, preferably passing through a hole sealed by a suitable gasket.

[0048] The impeller 8 is configured for imparting a thrust to the fluid which comes into contact with it, so as to provide a prevalence or pressure head increase to the fluid. The impeller 8 is preferably a centrifugal type impeller.

[0049] The pump main body 1 further comprises a secondary box 10 which houses electrical and electronic elements, such as an electronic control board 11, meant to supply power and to control the electric motor by cooperation with the electric/electronic connectors 3a and 3b.

[0050] Figure 3 shows a perspective view of the pump system 99, seen from a different angle, wherein some elements are more clearly visible.

[0051] In particular, it can be appreciated the structure of the hydraulic connector 101, which comprises a hollow pipe body 30 having a suction flange portion 31 at a first end, and an outlet section 15 at a second end which connects to the volute 2 of the pump main body 1, as it will be further described.

[0052] The suction flange portion 31 is structured for connecting to a piping system (not shown) in a fluid-tight manner, so as to supply the fluid to the pump system 99.

[0053] Figure 4 shows a partly disassembled isometric view of the pump system 99, while Figure 5 shows a sectioned view of the pump system 99, still partly disassembled.

[0054] As already mentioned, the volute 2 defines an inside volute chamber which houses the impeller, so that it is possible for a flow of fluid to reach the impeller 8.

[0055] The impeller discharges the fluid with increased pressure head into a discharge flange portion 12, which is provided downstream of the impeller 8. The discharge flange portion 12 is structured for connecting to a further piping system (not shown) in a fluid-tight manner.

[0056] The circulator pump 100 further comprises a volute flange portion 13 on a terminal side of the volute 2, which is directed towards the hydraulic connector 100, in operating conditions.

[0057] The volute flange portion 13 comprises an inlet hole 14, for the intake of a flow of fluid which enters the volute 2. In particular, the inlet hole 14 provides direct access to the volute chamber 9, so that in particular the impeller 8 is directly visible from the outside of the circulator pump main body 1 (although this is scarcely appreciable in Fig. 4, due to the selected angle of vision which privileges the overall structure of the pump system 99).

[0058] The volute 2 has an inlet hole 14 which is central, and is structured for coupling the circulator pump 100 in a releasable manner to the hydraulic connector 101 of the piping system.

[0059] The central inlet hole, in particular, is aligned with the axis of the impeller 8, and also with the axis of the electric motor 5, 6, 7.

[0060] The volute 2 is further structured with the lateral discharge flange portion 12 for coupling to an outlet portion of the piping system.

[0061] The volute flange portion 13 is structured for connecting in a fluid-tight manner to an outlet section 15 (not visible, it will be further described) of the hydraulic connector 101. The outlet section 15 comprises an outlet hole 16 (not visible, it will be further described) for the outflow of a fluid from the hydraulic connector 101 which connects to the piping system.

[0062] The circulator pump 100 further comprises a mating element 17 provided on the pump main body 1. In particular, in the preferred embodiment shown, the mating element 17 is provided on a surface of the volute 9, surrounding the whole pump main body 1 in a plane perpendicular to the shaft 7 of the electric motor.

[0063] The mating element 17 is structured for providing a releasable coupling between the volute flange portion 13 and the outlet section 15.

[0064] Preferably, the mating element 17 is structured for mating with a coupling flange portion 18 of the hydraulic connector 101. In particular, the coupling flange portion 18 is configured for mating with the mating element 17, having a matching shape.

[0065] The mating element 17, by engaging with at least one releasable retaining element 20, is thus structured to releasably couple the volute flange portion 13 of the circulator pump 100, with the outlet section 15 of the hydraulic connector 101.

[0066] In this preferred embodiment, three releasable retaining elements or screw 20 are provided to connect the mating element 17 with the coupling flange portion 18, as it will be further described.

[0067] Preferably, the mating element 17 comprises a plurality of engaging elements 21, structured for coupling with the coupling flange portion 18 of the hydraulic connector 101. These engaging elements 21, preferably three engaging elements 21, comprise respective holed portions, each structured for receiving the respective retaining element or screw 20.

[0068] Preferably, the mating element 17 is further associated with at least one seal element 22, preferably an O-ring 22, which is interposed between the volute flange portion 13 and the outlet hole 16, so as to improve the fluid-tight connection therein.

[0069] Preferably, the discharge flange portion 12 is located, in operating conditions, at a higher level than the level of the volute flange portion 13.

[0070] More preferably, discharge flange portion 12 is located above a top surface of the circulator pump main body 1.

[0071] Focusing now on the hydraulic connector 101, it comprises a hollow pipe body 30 for providing a flow of a fluid to the circulator pump 100.

[0072] The hollow pipe body 30 comprises a suction flange portion 31 provided at a first one of

its ends. The suction flange portion 31 is structured for connecting to a piping system (not shown) in a fluid-tight manner, for the intake of fluid to be passed to the circulator pump 100.

[0073] The hollow pipe body 30 further comprises an outlet section 15 provided at a second one of its ends. As already said, the outlet section 15 is structured for connecting to the volute flange portion 13 of the circulator pump 100 in a fluid-tight manner. The outlet section 15 comprises an outlet hole 16 for the flow of the fluid. The flow of said fluid, after passing the outlet hole 16, enters the inlet hole 14 of the volute flange portion 13 of the volute 2.

[0074] The hydraulic connector 101 further comprises a connection element 32 provided at its second end. The connection element 32 is structured for providing a releasable coupling between the outlet section 15 and the volute flange portion 13.

[0075] Preferably, the connection element 32 comprises the coupling flange portion 18, which is structured for mating with a respective surface of the mating element 17 of the circulator pump 100 main body, as already described.

[0076] In particular, the coupling flange portion 18 comprises a coupling surface 19 for mating with at the mating element 17; the coupling surface 19 is structured for engaging with at least one releasable retaining element 20, preferably with three screws 20, for coupling of the outlet section 15 with the volute flange portion 13.

[0077] In particular, the connection element 32 comprises a semi-shell-like shaped coupling body, which defines the coupling flange portion 18.

[0078] The coupling surface on the semi-shell-like shaped body is structured for engaging with engaging elements 21 provided on a surface of the mating element 17 of the circulator pump 100.

[0079] In particular, the coupling surface 19 comprises at least one, preferably three, threaded portions 19, structured for receiving a respective releasable retaining element 20, said releasable retaining element being each screw 20.

[0080] Preferably, the hydraulic connector 101 further comprises at least one seal element 22, preferably an O-ring 22, which is interposed between the outlet hole 16 and the volute flange portion 13, so as to improve the fluid-tight connection therein.

[0081] Preferably, the hollow pipe body 30 further comprises at least a first auxiliary opening 33 structured for connecting to an expansion vase (not shown), by providing fluid connection thereto. The expansion vase is an effective component in the piping system, which is advantageously located close to the pump system 99. Preferably the first auxiliary opening 33 is located, in operating conditions, at a higher level than the level of the outlet hole 16. More preferably, the first auxiliary opening 33 is connected to a first auxiliary channel 34 located at the second end of the hollow pipe body 30.

[0082] Preferably, the hollow pipe body 30 further comprises at least a second auxiliary opening 35 structured for connecting to a valve (not shown), in particular to a safety valve, by providing fluid connection therein. The safety valve is an effective component in the piping system, which is advantageously located close to the pump system 99. The second auxiliary opening 35 is located, in operating conditions, at a lower level than the level of the suction flange portion 31. The second auxiliary opening 35 is preferably connected to a second auxiliary channel 36 located at a first end of the hollow pipe body 30.

[0083] The overall pump system 99 will be now briefly described.

[0084] It is apparent that such pump system 99 corresponds to the combination of the circulator pump 100 and of the hydraulic connector 101, to be assembled together.

[0085] The pump system 99 comprises the impeller 8, the electric motor 5, 6, 7 for rotating the impeller 8, a volute 2 defining a volute chamber 9 for housing the impeller 8 and for providing fluid-tightness in the circulator pump main body 1, for a flow of fluid passing through the impeller 8.

[0086] A hollow pipe body 30 brings a fluid flow to the impeller 8. A suction flange portion 31 is provided at a first end of the hollow pipe 30 and is structured for connecting to a piping system (not shown) in a fluid-tight manner.

[0087] An outlet section 15 is provided at a second end of the hollow pipe 30, and comprises an outlet hole 16 for the flow of the fluid.

[0088] A discharge flange portion 12 is provided downstream of the impeller 8 and is structured for connecting to a piping system (not shown) in a fluid-tight manner.

[0089] A volute flange portion 13 allows the fluid, coming from the outlet section 15, to enter the volute 2 by means of an inlet hole 14.

[0090] The outlet section 15 and the volute flange portion 13 are connected in a fluid-tight manner.

[0091] A connection element 32 is provided at the second end of the hollow pipe body 30. A mating element 17 is provided on the circulator pump main body 1.

[0092] The connection element 32 and the mating element 17 are structured for respectively coupling with each other, and for providing a releasable coupling between the volute flange portion 13 and the outlet section 15.

[0093] Figure 6 shows a perspective view of a pump system, 99' according to an embodiment of the present invention.

[0094] The pump system 99' comprises a circulator pump 100, as already described. The pump system 99' also comprises a hydraulic connector 201 according to the invention.

[0095] The hydraulic connector 201 provides for a different connection element, which provides a releasable coupling between its outlet section and the volute flange portion 13 of the already described circulator pump 100.

[0096] Figure 7 shows a partly disassembled view of the pump system 99', comprising the hydraulic connector 201. Figure 8 shows yet a different view of the pump system 99', so as to visualize all its elements.

[0097] The mating element 17 comprises a circular shaped coupling body on the volute flange portion 13. In this embodiment, it is the circular shaped coupling body which is structured to engage with the outlet section 51 of the hydraulic connector 201.

[0098] The circular shaped periphery of the volute flange portion 13 is structured for interacting with a retaining element 52 being a resilient fixing clip.

[0099] The resilient fixing clip 52 cooperates with respective slots 53. There are preferably four peripheral slots 53 for receiving the releasable retaining element 52.

[0100] The releasable retaining element 52 acts on the circular shaped periphery of the volute flange portion 13, so as to retain the elements and provide a coupling with the outlet section 51.

[0101] On the side of the hydraulic connector 201, in particular, the connection element 32' comprises a circular shaped coupling body on the outlet section 51, which is configured for mating with the respective mating element 17, which also comprises a circular shaped coupling body on the volute flange portion 13.

[0102] The circular shaped coupling body of the connection element 32' is structured for engaging with the volute flange portion 13 and comprises preferably four peripheral slots 53 for receiving the releasable retaining element 52. The releasable retaining element 52 is a fixing clip structured for acting on the periphery of the circular shaped volute flange portion 13.

[0103] Although the present invention has been described in considerable detail with reference to certain preferred embodiments thereof, other variants may become apparent to those skilled in the art who consider the present description.

[0104] The scope of the invention is defined by the appended claims.

REFERENCES CITED IN THE DESCRIPTION

Cited references

This list of references cited by the applicant is for the reader's convenience only. It does not form part of the European patent document. Even though great care has been taken in compiling the references, errors or omissions cannot be excluded and the EPO disclaims all liability in this regard.

Patent documents cited in the description

- WO2014195001A1 [0013]

PATENTKRAV

1. Hydraulisk forbindelse (201) til en cirkulationspumpe (100), omfattende:

5 et hult rørlegeme (30) til strømning af et fluid, hvilket hult rørlegeme (30) omfatter en sugeflangedel (31) tilvejebragt ved en første ende af det hule rørlegeme (30) og struktureret til forbindelse med et rørledningssystem på en fluidtæt måde, hvilket hult rørlegeme (30) yderligere omfatter et udløbsafsnit (51) tilvejebragt ved en

10 anden ende af det hule rørlegeme (30), hvilket udløbsafsnit (51) er struktureret til forbindelse med en volutflangedel (13) på en cirkulationspumpe (100) på en fluidtæt måde, hvilket udløbsafsnit (51) omfatter et udløbshul (16) til strømningen af fluidet,

hvilken hydraulisk forbindelse (201) yderligere omfatter et forbindelseselement (32'), hvilket forbindelseselement (32') er tilvejebragt ved den anden ende og er

15 struktureret til at tilvejebringe en udløselig forbindelse imellem udløbsafsnittet (51) og volutflangedelen (13),

hvilket forbindelseselement (32') yderligere omfatter en forbindelsesflangedel (18) med en koblingsflade (19) struktureret til at passe sammen med et respektivt samspasningselement (17) på et cirkulationspumpehovedlegeme (1), hvilken kob-

20 lingsflade (19) er struktureret til at indgribe med i det mindste ét udløseligt fastholdelseselement (52) til at forbinde udløbsafsnittet (51) med volutflangedelen (13),

kendetegnet ved, at forbindelseselementet (32) omfatter et cirkulært formet koblingslegeme på udløbsafsnittet (51), hvilket cirkulært formet koblingslegeme er struktureret til at indgribe med en volutflangedel (13) på et cirkulationspumpe-

25 hovedlegeme (1),

hvilket cirkulært formet koblingslegeme omfatter adskillige, fortrinsvis fire, perifere slidser (53) til at modtage det udløselige fastholdelseselement (52), hvilket udløseligt fastholdelseselement (52) er en elastisk fikseringsclips (52), som er struktureret til at virke på periferien af volutflangedelen (13).

30

2. Hydraulisk forbindelse (201) ifølge krav 1, som yderligere omfatter i det mindste ét tætningsselement (22), fortrinsvis en O-ring (22), som er anbragt imellem udløbshullet (16) på udløbsafsnittet (51) og volutflangedelen (13), hvilket tætningsselement (22) er struktureret til at forbedre den fluidtætte forbindelse derpå.

35

3. Hydraulisk forbindelse (201) ifølge ethvert af kravene 1 eller 2, hvor det hule rørlegeme (30) yderligere omfatter i det mindste en første hjælpeåbning (33) struktureret til forbindelse med en ekspansionsbeholder, ved tilvejebringelse af fluidforbindelse dertil, hvilken første hjælpeåbning (33) er placeret, i driftstilstanden, ved et højere niveau end niveauet for udløbshullet (16), hvilken første hjælpeåbning (33) fortrinsvis er forbundet med en første hjælpekanal (34) placeret ved den anden ende af det hule rørlegeme (30).

4. Hydraulisk forbindelse (201) ifølge ethvert af kravene 1 til 3, hvor det hule rørlegeme (30) yderligere omfatter i det mindste én anden hjælpeåbning (35) struktureret til forbindelse med en ventil, især en sikkerhedsventil, ved tilvejebringelse af fluidforbindelse dertil, hvilken anden hjælpeåbning (35) er placeret, i driftstilstanden, ved et lavere niveau end niveauet for sugeflangeafsnittet (31), hvilken anden hjælpeåbning (35) fortrinsvis er forbundet med en anden hjælpekanal (36) placeret ved den første ende af det hule rørlegeme (30).

5. Pumpesystem (99'), omfattende:

en cirkulationspumpe (100) med et cirkulationspumpehovedlegeme (1) til montering på et rørledningssystem og omfattende en impeller (8); en elektrisk motor (5, 6, 7) til at rotere impelleren; en volut (2), som definerer et volutkammer (9) til at indeholde impelleren (8); og

en hydraulisk forbindelse (201) ifølge ethvert af kravene 1 til 4, hvor volutten (2) har et centralt indløbshul (14) til at forbinde cirkulationspumpen (100) på en udløselig måde med hydraulikforbindelsen (201), hvilken volut (2) yderligere er struktureret med en sideværts udløbsflangedel (12) til forbindelse med en udløbsdelen af rørledningssystemet,

hvor volutten (2) definerer et volutkammer (9) for tilvejebringelse af fluidtæthed i cirkulationspumpehovedlegemet (1) for en strømning af fluid, som passerer via impelleren (8);

hvor udløbsflangedelen (12) er tilvejebragt nedstrøms for impelleren (8) og er struktureret til forbindelse med rørledningssystemet på en fluidtæt måde;

hvor cirkulationspumpen (100) yderligere omfatter:

en volutflangedel (13) omfattende indløbshullet (14) for strømningen af fluidet ind i volutten (2),

volutflangedelen (13) er struktureret til forbindelse på en fluidtæt måde med udløbsafsnittet (51) i hydraulikforbindelsen (201);
 hvor cirkulationspumpen (100) yderligere omfatter et sampasningselement (17) tilvejebragt på cirkulationspumpehovedlegemet (1),
 5 hvilket sampasningselement er struktureret til at tilvejebringe en udløselig forbindelse imellem volutflangedelen (13) og udløbsafsnittet (51),
 hvor sampasningselementet (17) er struktureret til sampasning med en koblingsflangedel (18) på hydraulikforbindelsen (201), ved at indgribe med det i det mindste ene udløselige fastholdelseselement (52), til udløseligt at forbinde
 10 volutflangedelen (13) med udløbsafsnittet (51),
kendetegnet ved, at sampasningselementet (17) omfatter et cirkulært formet koblingslegeme på volutflangedelen (13), som er struktureret til at indgribe med udløbsafsnittet (51) på hydraulikforbindelsen (201), hvor den cirkulært formede periferi af volutflangedelen (13) er struktureret til at samvirke med det udløselige fastholdelseselement (52), som omfatter en elastisk fikseringsclips (52),
 15 som er struktureret til at samvirke med respektive slidser (53).

6. Pumpesystem (99') ifølge krav 5, hvor indløbshullet (14) til volutflangedelen (13) tilvejebringer direkte adgang til volutkammeret (9), hvorved impelleren (8) fortrinsvis er
 20 synlig fra ydersiden af cirkulationspumpehovedlegemet (1).

7. Pumpesystem (99') ifølge ethvert af kravene 5 eller 6, hvor sampasningselementet (17) er tilvejebragt på i det mindste én overflade af volutten (2) på cirkulationspumpehovedlegemet (1).
 25

8. Pumpesystem (99') ifølge ethvert af kravene 5 til 7, hvor sampasningselementet (17) yderligere er knyttet til i det mindste ét tætningselement (22), fortrinsvis en O-ring (22), som er anbragt imellem volutflangedelen (13) og udløbshullet (16), hvilket i det mindste ene tætningselement (22) er struktureret til at forbedre den fluidtætte forbindelse.
 30

9. Pumpesystem (99') ifølge ethvert af kravene 5 til 8, hvor udløbsflangedelen (12) er placeret, i driftstilstanden, ved et højere niveau end niveauet for volutflangedelen (13), fortrinsvis over en øvre overflade for cirkulationspumpehovedlegemet (1).
 35

10. Pumpesystem (99') ifølge ethvert af kravene 5 til 9, hvor impelleren (8) er af centrifugaltypen.

11. Pumpesystem (99') ifølge ethvert af kravene 5 til 10, hvor den elektriske motor (5, 5 6, 7) er af synkrontypen.

12. Rørledningssystem, fortrinsvis et varme- og/eller kølesystem, omfattende et pumpe­system (99') ifølge ethvert af kravene 5 til 11.

10

DRAWINGS

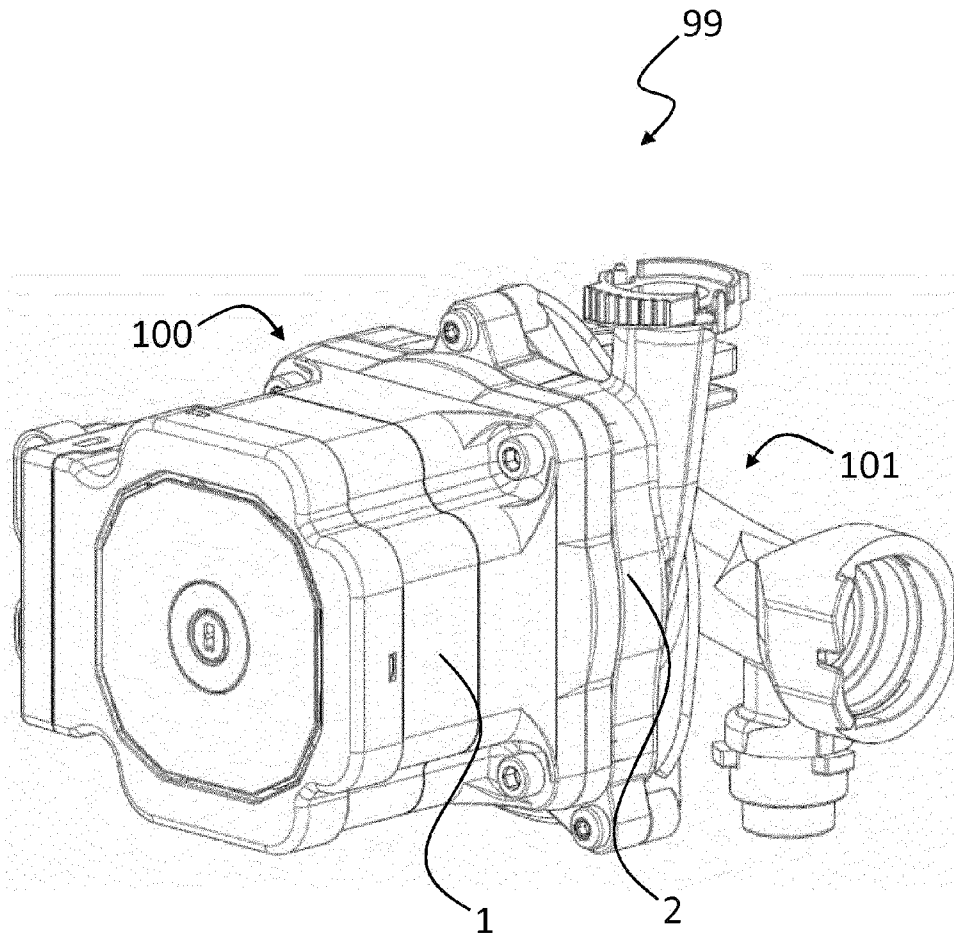

FIG. 1

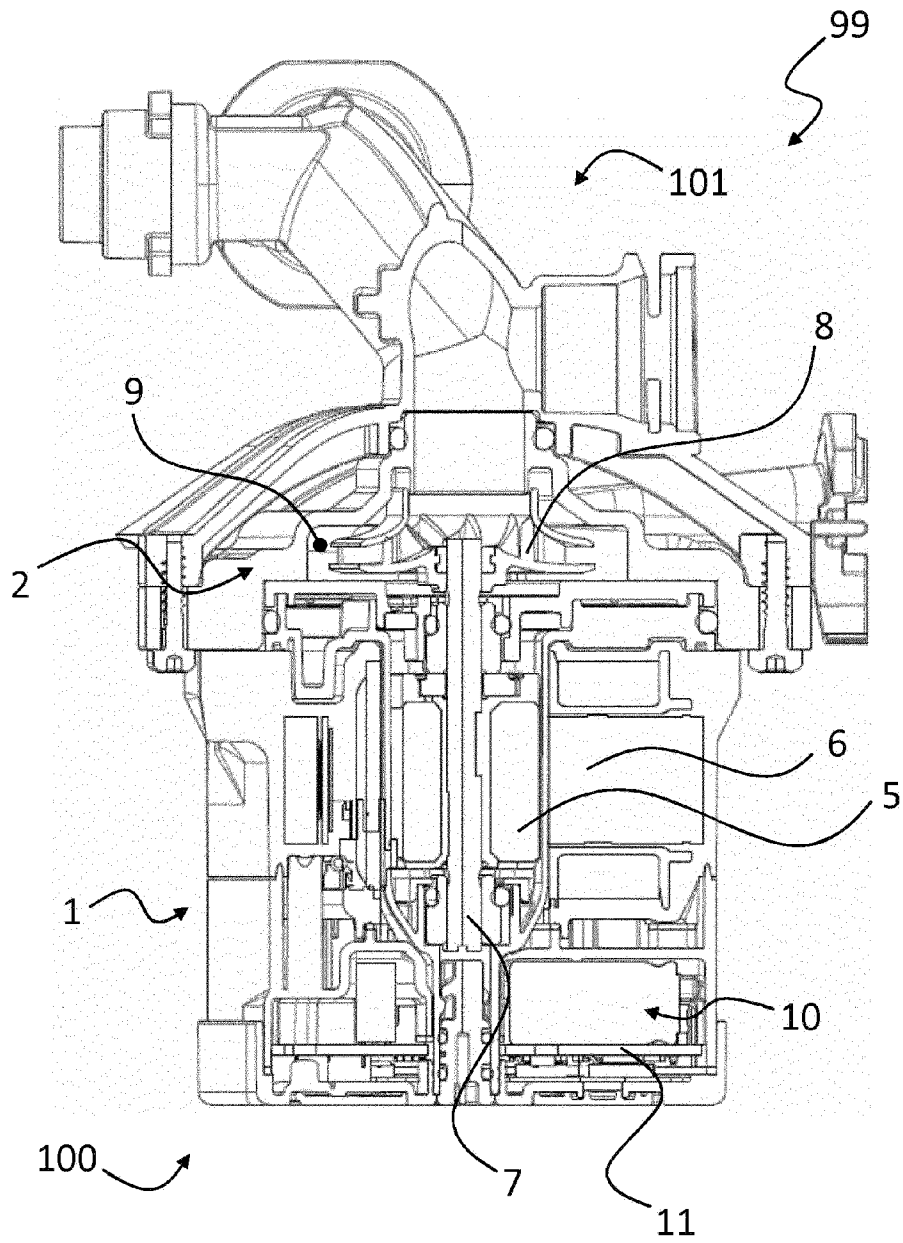

FIG. 2

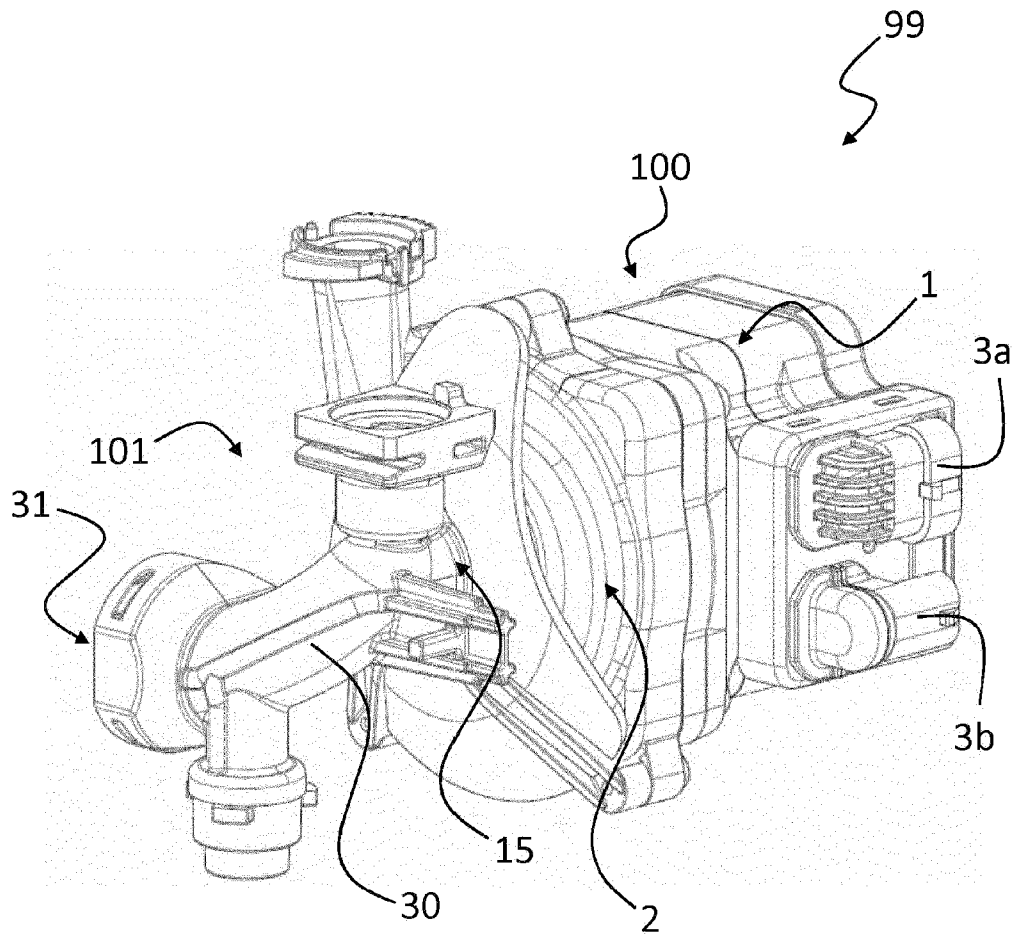

FIG. 3

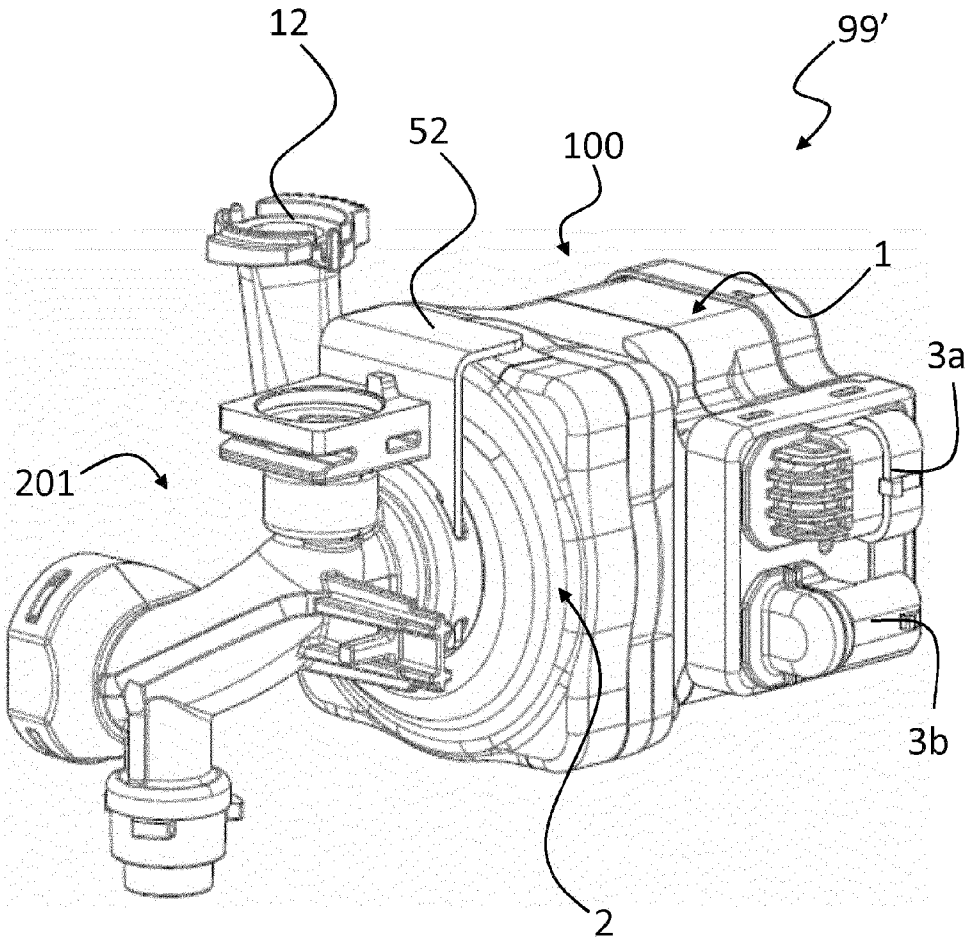

FIG. 6

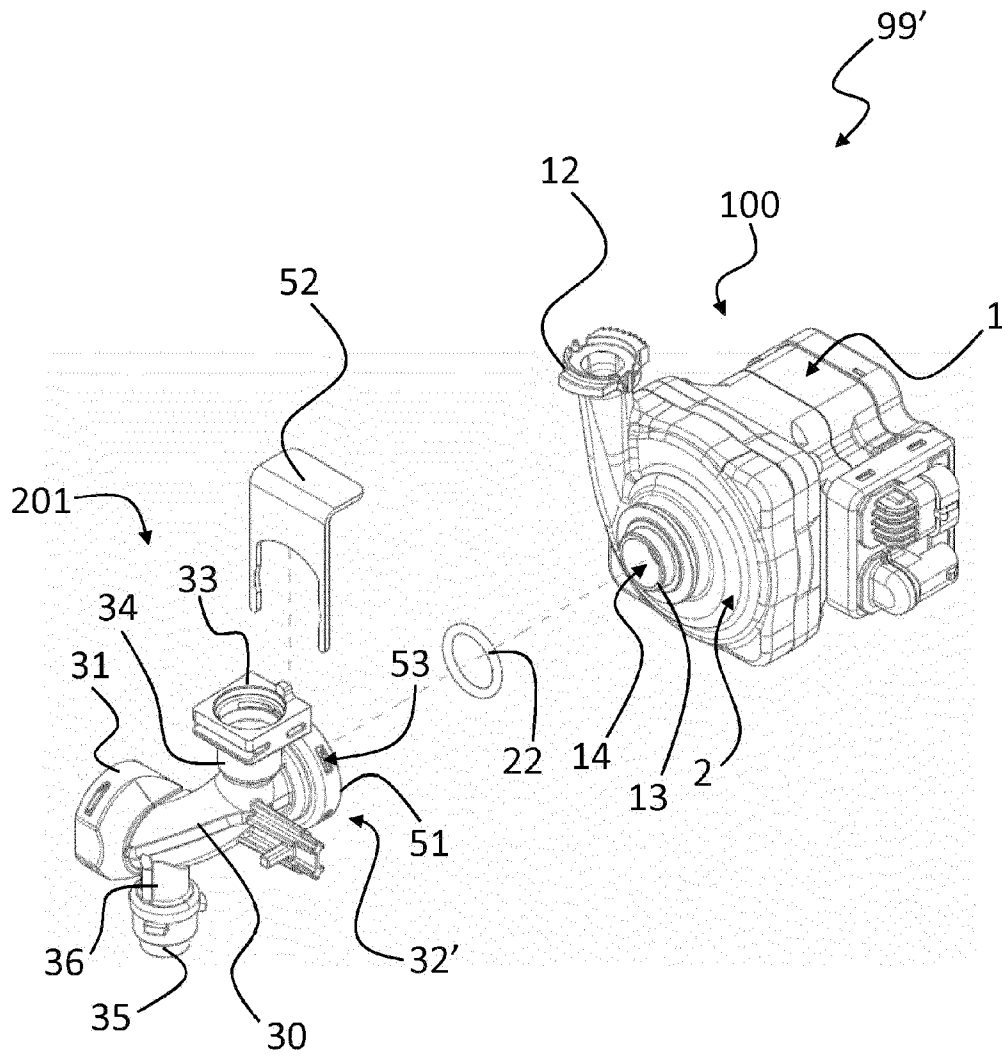

FIG. 7

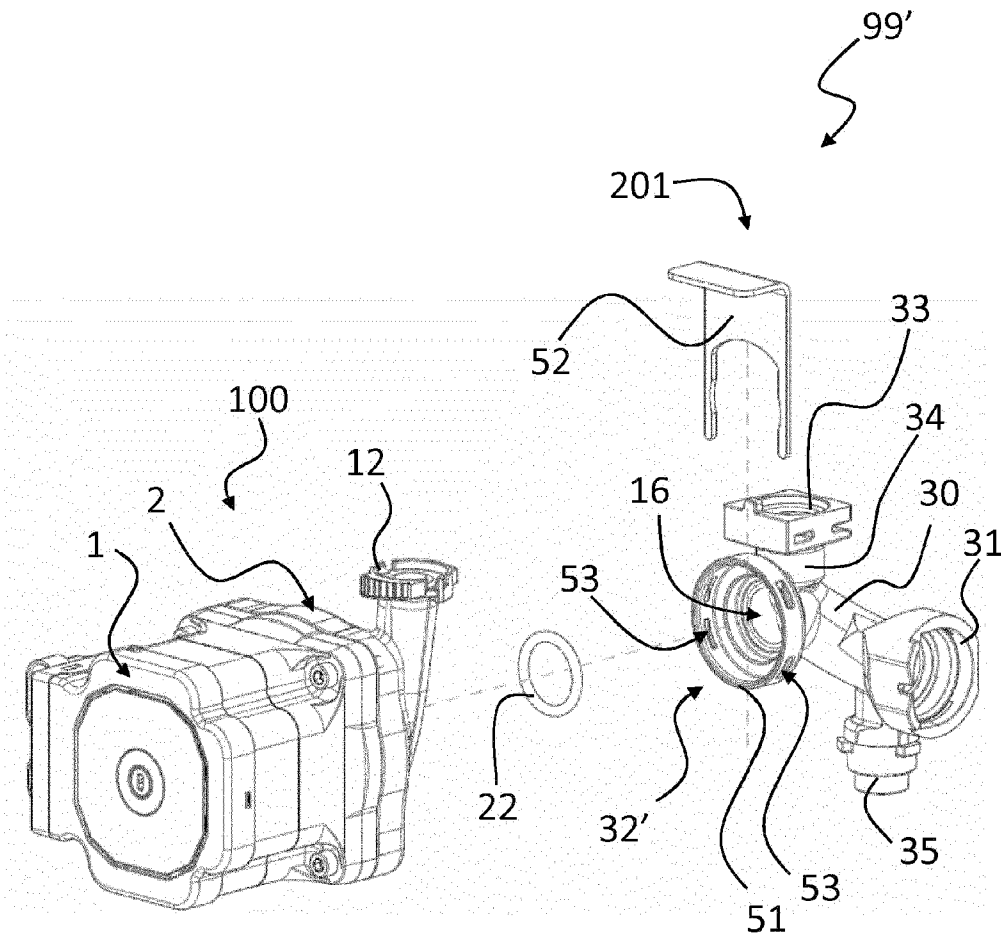

FIG. 8