



- (51) **International Patent Classification:**
A61B 5/00 (2006.01) *A41D 1/00* (2006.01)
A61B 5/0205 (2006.01)
- (21) **International Application Number:** PCT/IB2016/001146
- (22) **International Filing Date:** 20 July 2016 (20.07.2016)
- (25) **Filing Language:** English
- (26) **Publication Language:** English
- (30) **Priority Data:**
62/194,731 20 July 2015 (20.07.2015) US
- (71) **Applicant:** L.I.F.E. CORPORATION S.A. [LU/LU]; 20, rue Jean-Pierre Beicht, L-1226 Luxembourg (LU).
- (72) **Inventors:** LONGINOTTI-BUITONI, Gianluigi; 20, Rue Jean-Pierre Beicht, L-1226 Luxembourg (LU). ALIVERTI, Andrea; 20, rue Jean-Pierre Beicht, L-1226 Luxembourg (LU). PALLAI, Fabrizio; 20, rue Jean-Pierre Beicht, L-1226 Luxembourg (LU).
- (74) **Agent:** PRICE, Nigel John King; J.A. Kemp & CO., 14 South Square, Gray's Inn, London WC1R 5JJ (GB).
- (81) **Designated States** (*unless otherwise indicated, for every kind of national protection available*): AE, AG, AL, AM,

AO, AT, AU, AZ, BA, BB, BG, BH, BN, BR, BW, BY, BZ, CA, CH, CL, CN, CO, CR, CU, CZ, DE, DK, DM, DO, DZ, EC, EE, EG, ES, FI, GB, GD, GE, GH, GM, GT, HN, HR, HU, ID, IL, IN, IR, IS, JP, KE, KG, KN, KP, KR, KZ, LA, LC, LK, LR, LS, LU, LY, MA, MD, ME, MG, MK, MN, MW, MX, MY, MZ, NA, NG, NI, NO, NZ, OM, PA, PE, PG, PH, PL, PT, QA, RO, RS, RU, RW, SA, SC, SD, SE, SG, SK, SL, SM, ST, SV, SY, TH, TJ, TM, TN, TR, TT, TZ, UA, UG, US, UZ, VC, VN, ZA, ZM, ZW.

- (84) **Designated States** (*unless otherwise indicated, for every kind of regional protection available*): ARIPO (BW, GH, GM, KE, LR, LS, MW, MZ, NA, RW, SD, SL, ST, SZ, TZ, UG, ZM, ZW), Eurasian (AM, AZ, BY, KG, KZ, RU, TJ, TM), European (AL, AT, BE, BG, CH, CY, CZ, DE, DK, EE, ES, FI, FR, GB, GR, HR, HU, IE, IS, IT, LT, LU, LV, MC, MK, MT, NL, NO, PL, PT, RO, RS, SE, SI, SK, SM, TR), OAPI (BF, BJ, CF, CG, CI, CM, GA, GN, GQ, GW, KM, ML, MR, NE, SN, TD, TG).

Published:

- *with international search report (Art. 21(3))*
- *before the expiration of the time limit for amending the claims and to be republished in the event of receipt of amendments (Rule 48.2(h))*



WO 2017/013493 A1

(54) **Title:** FLEXIBLE FABRIC RIBBON CONNECTORS FOR GARMENTS WITH SENSORS AND ELECTRONICS

(57) **Abstract:** Elastic electrical connectors that may be incorporated into a garment to connect multiple electrical components in the garment. These electrical connectors are typically long strips of fabric substrate to which wires are attached along a length of one side in a sinusoidal or zig-zag pattern. The connector may also include an adhesive coating on one side to secure it to a fabric. The wires are electrically insulated, which may be a thermoremovable insulation (e.g., a polyurethane having a melting point of <400°C). The wires may be attached to the surface of the fabric strip by a stitch at each peak and trough of the sinusoidal or zig-zag pattern with a length between peak and trough stitches between about 1 mm and 15 mm.

**FLEXIBLE FABRIC RIBBON CONNECTORS FOR GARMENTS WITH SENSORS AND
ELECTRONICS**

CROSS REFERENCE TO RELATED APPLICATIONS

5 [0001] This application claims priority to U.S. provisional patent application no. 62/194,731, titled “FLEXIBLE FABRIC RIBBON CONNECTORS FOR GARMENTS WITH SENSORS AND ELECTRONICS”, and filed on 7/20/2015.

[0002] This application may be related to US. Application no. 14/612,060, filed on February 2, 2015 (“GARMENTS HAVING STRETCHABLE AND CONDUCTIVE INK”), which is a continuation of
10 U.S. application no. 14/331,142 filed July 14, 2014 (“COMPRESSION GARMETS HAVING STRETCHABLE AND CONDUCTIVE INK”). This application may also be related to U.S. application no. 14/644,180, filed March 10, 2015 (“PHYSIOLOGICAL MONITORING GARMENTS”), which claimed priority to U.S. provisional patent application no. 62/097,560, filed on December 29, 2015 (“STRETCHABLE, CONDUCTIVE TRACES AND METHODS OF MAKING AND USING SAME”).

15

INCORPORATION BY REFERENCE

[0003] All publications and patent applications mentioned in this specification are herein incorporated by reference in their entirety to the same extent as if each individual publication or patent application was specifically and individually indicated to be incorporated by reference.

20

FIELD

[0004] The disclosure herein relates to electrical connectors for garments having multiple integrated electrical components (including sensors). In particular, this disclosure relates to strips of elastic electrical connectors that may be used to connect multiple electrical devices on a garment having
25 integrated electrical devices.

BACKGROUND

[0005] In recent years the development of wearable electronics has dramatically expanded. Computers with ever-faster computer processors enabled faster communication with increased processing
30 speed and improved analysis of vast quantities of data. In addition, sensor technology has also rapidly expanded how patients have been monitored, even by non-professionals. The development of various sensors enabled a variety of measurements to be taken and analyzed by a computer to generate useful information. The use of medical sensing technology in combination with various communications platforms may provide new and interesting ways for people, including patients, to be monitored or to
35 monitor themselves and communicate the results of the monitoring with their physician or caregiver.

[0006] Cardiovascular and other health-related problems, including respiratory problems may be detected by monitoring a patient. Monitoring may allow early and effective intervention, and medical assistance may be obtained based on monitored physiological characteristics before a particular health issue becomes fatal. Unfortunately, most currently available cardiovascular and other types of health monitoring systems are cumbersome and inconvenient (e.g., impractical for everyday use) and in particular, are difficult or impractical to use for long-term monitoring, particularly in an unobtrusive manner.

[0007] Clothing that includes sensors have been previously suggested. See, e.g., US2007/0178716 to Glaser et al., which describes a “modular microelectronic-system” designed for use with wearable electronics. US2012/0071039 to Debock et al. describes interconnect and termination methodology for textiles that include a “conductive layer that includes conductors includes a terminal and a base separately provided from the terminal. The terminal has a mating end and a mounting end.” US2005/0029680 to Jung et al. describes a method and apparatus for the integration of electronics in textiles. These wearable electronic garments are limited however, in their ability to comfortably and accurately link electronics (including sensors) on the garment.

[0008] It has been proposed that patient health parameters, including vital signs (such as ECG, respiration, blood oxygenation, heart rate, etc.) could be actively monitoring using one or more wearable monitors, however, to date such monitors have proven difficult to use and relatively inaccurate. Ideally such monitors could be unobtrusively worn by the subject (e.g., as part of a garment, jewelry, or the like). To date, the wearable electronics garments proposed all suffer from a number of deficits, including being uncomfortable, difficult to use and manufacture, and providing inaccurate results. For example, in applications such as US 2012/0136231, a number of individual electrodes are positioned on the garment and connected to a processor by woven conductive fibers or the like; although such garments “require... consistent and firm conductive contact with the subject’s skin,” in order to provide accurate readings, such designs require that the garment be restrictive in order to prevent movement of the garment (and thus sensors) contacting these skin regions. Such a configuration rapidly becomes uncomfortable, particularly in a garment that would ideally be worn for many hours or even days. In addition, even such tightly worn garments often move relative to the wearer (e.g., slip or ride up). Further, devices/garments such as those described in the prior art are difficult and expensive to manufacture, and are often rather “fragile”, preventing robust usage and washing. Finally, such devices/garments typically do not allow processing of manual user input directly on the garment, but either relay entirely on passive monitoring, or require an interface of some sort (including off-garment interfaces).

[0009] The use of garments including one or more sensors that may sense biometric data have not found widespread use. In part, this may be because such garments may be limited in the kinds and versatility of the inputs that they accept, as well as limits in the comfort, and form factor of the garment. For example, sensors, and the leads providing power to and receiving signals from the sensors have not been fully integrated with the garment in a way that allows the garment to be flexible, attractive, practical, and above all, comfortable. For example, most such proposed garments have not been sufficiently

stretchable. Finally, such proposed garments are also limited in the kind of data that they can receive, and how they process the received information.

[00010] What is needed are apparatuses (including garments) having multiple sensors that may be comfortably worn, yet provide relatively accurate and movement-insensitive measurements over a sustained period of time. It would also be beneficial to provide garments that can be easily and inexpensively manufactured.

[00011] In particular, what is needed are stretchable and conductive connectors that can be attached or applied onto a garment. These stretchable, conductive connectors may be used even with the most stretchable of fabrics, and/or with compression fabrics/compression garments, and moved through numerous stretch/relaxation cycles with the underlying fabric without breaking and while maintaining a stable electrical connection over time and use. The apparatuses, including devices and systems including them described herein may address some or all of the problems identified above.

SUMMARY OF THE DISCLOSURE

[00012] Described herein are strips of elastic electrical connectors that may be used to connect multiple electrical devices on a garment having integrated electrical devices (including sensors). These strips of elastic electrical connectors may be adhesively applied to a garment (or a fabric to form a garment) and may be comfortably worn while providing robust electrical connection.

[00013] For example, described herein are elastic electrical connector devices for incorporating into a garment to connect multiple electrical components in the garment. Such devices may include: an elongate strip of fabric substrate having a first side and a second side; a plurality of wires extending along a length of the first side of the elongate strip of fabric substrate in a sinusoidal or zig-zag pattern, wherein each of the wires is electrically insulated, and wherein the plurality of wires are attached to the first surface by a stitch at a peak and a trough of the sinusoidal or zig-zag pattern; and an adhesive coating the first side.

[00014] As used herein, a sinusoidal pattern is a curve that describes a repeating (or oscillating) pattern, and may broadly include zig-zag, saw-tooth, (e.g., triangular), smooth, or other repeating waves having a peak and a trough, where the peak and trough are connected by non-vertical paths (e.g., excluding purely square waveforms). Thus, in general the oscillating pattern of the wires in any of the apparatuses (e.g., devices, garments, etc.) described herein may be referred to as an oscillating pattern having a series of longitudinally repeating peaks and troughs, wherein each peak is followed by an adjacent trough and separated by a longitudinal distance (e.g., greater than 0.1 mm, 0.5 mm, 1 mm, etc.) and separated by a vertical distance (e.g., amplitude).

[00015] Any of these elastic electrical connector device for incorporating into a garment to connect multiple electrical components in the garment may include: an elongate strip of fabric substrate having a first side with a length; a bundle of wires that are twisted together extending along the length of the first side of the elongate strip of fabric substrate in a sinusoidal or zig-zag pattern, wherein each of the wires is electrically insulated with a thermoremovable insulator, and wherein the bundle of wires are attached to

the first surface by a stitch at each peak and trough of the sinusoidal or zig-zag pattern wherein the length between peak and trough stitches is between about 1 mm and 15 mm; and an adhesive coating the first side.

5 [00016] The elastic electrical connector may be a generally thin strip (e.g., ribbon, band, etc.) that may be relatively thin and narrow. For example, the strip may have a maximum thickness of less than about 2 mm (e.g., less than about 1.9 mm, less than about 1.8 mm, less than about 1.7 mm, less than about 1.6 mm, less than about 1.5 mm, less than about 1.4 mm, less than about 1.3 mm, less than about 1.2 mm, less than about 1.1 mm, less than about 1.0 mm, etc.).

10 [00017] The elastic electrical connector may be any appropriate length and thickness. For example, the elastic electrical connector (the elongate strip of fabric substrate of the elastic electrical connector) may be between about 0.6 mm and about 3 cm wide, and greater than about 10 cm long. The length may extend for meters, including greater than 1 m, greater than 2 m, greater than 3 m, etc. the elastic electrical connector may be spooled up so that it may be cut to fit and conveniently used in a variety of fabrications.

15 [00018] The plurality of wires comprises a bundle of wires twisted together. In some variations, the plurality may be wires arranged in parallel. The plurality of wires generally includes between 2 and 20 (e.g., between 2 and 18, 2 and 17, 2 and 16, 2 and 15, 2 and 14, 2 and 13, 2 and 12, 2 and 11, 2 and 10, 2 and 9, 2 and 8, 2, etc.). In general, each of the wires is individually coded along its outer length, so that it may be distinguished from the other wires. For example, each wire may be a distinct color and/or pattern (e.g., printed on the outer visible surface of the wire. When the plurality is a bundle of wires, the wires
20 are typically individually electrically insulated. Thus, the bundle is not encased or enclosed as a group, so that they can be individually separated out from the bundle, though pulled out of the stitch or attachment holding them to the substrate fabric.

[00019] As mentioned, each wire is typically individually electrically insulated, and this electrical insulation may be configured as a thermoremovable insulator that can be removed by application of a
25 relatively low heat, as applied during soldering. Thus, the wires may not need to be separately stripped or removed of the insulation. For example, the wires may be made of a copper wire that is electrically insulated with a polyurethane.

30 [00020] The wires are typically attached on one side of the substrate (fabric) in a sinusoidal pattern, or more specifically a zig-zag pattern. For example, the sinusoid or zig-zag pattern may have an amplitude (from peak to trough, measured in a direction normal to the zig-zag pattern) that is from about 0.2 mm to 20 mm (e.g., from 0.5 mm to about 15 mm, etc.). The distance between the peak and trough measured along the sinusoidal (e.g., zig-zag) pattern, e.g., a length between peak and trough stitches, may be between about 0.5 mm and about 20 mm (e.g., between about 1 mm and 15 mm, etc.).

35 [00021] The elastic electrical connector typically has a relaxed configuration (e.g., unstretched) and a stretched configuration. The garment may be stretched up to about 100% (2x) or more (e.g., 200%, 300%, etc.) of its relaxed configuration without breaking one of the connecting wires.

[00022] In some variations, it is helpful that the wires (e.g., bundle of wires) are held to the garment by one or more stitches at the peak and trough of the sinusoidal pattern, as through stitches around the

wires that pass through the substrate. This configuration may allow the stitches to act as eyelets that the wires may slide, while still maintaining the shape of the sinusoid.

[00023] In any of the elastic electrical connectors described herein the adhesive coating may be a relatively thin adhesive coating. For example, the adhesive coating may comprise a hot melt film having a low melting point. The adhesive coating may have a thickness of between 10 and 200 micrometers thick (e.g., 20 and 190, 30 and 180, 40 and 170, 50 and 160, 60 and 150, etc., or any thickness between 10 and 200 micrometers. The actual thickness may depend on the material, though thinner coatings are preferred. The adhesive is configured to secure the elastic electrical connector to the garment that it will form a part of. Thus, any appropriate garment-compatible (and somewhat elastic and/or flexible) adhesive may be used. For example, the adhesive coating comprises a hot melt film having a melting point of between about 130 °C and 200°C.

[00024] In any of these variations, the substrate fabric may be formed of the same fabric as the garment to which the elongate strip of fabric substrate is to be attached, including a stretchable fabric substrate. For example, the elongate strip of fabric substrate may comprise a polyamide/elastane blend fabric (e.g., 74% polyamide, 26% elastane).

[00025] Any of these devices (elastic electrical connectors) may include a removable backing on the first side covering the adhesive. The back may be paper (e.g., waxed paper), plastic, or the like, and may be peeled off to expose the adhesive.

[00026] Also described herein are elastic electrical connector device for incorporating into a garment to connect multiple electrical components in the garment, the device comprising: an elongate strip of fabric substrate having a first side and a second side; a plurality of wires extending along a length of the first side of the elongate strip of fabric substrate in a sinusoidal or zig-zag pattern, wherein each of the wires is electrically insulated, and wherein the plurality of wires are attached to the first surface; and an adhesive coating the first side.

[00027] Method of making these elastic electrical connectors are also described herein. A method of forming an elastic electrical connector that may be applied to a garment to connect multiple electrical components of the garment may include: attaching an elongate bundle of wires to a first surface of an elongate strip of fabric in a sinusoidal or zig-zag pattern comprising alternating peaks and troughs, wherein the wires are each electrically insulated, and wherein the bundle is attached to the first surface by at least one stitch at each peak and trough of the sinusoidal or zig-zag pattern, wherein the length between peak and trough stitches is between about 1 mm and 15 mm; applying an adhesive coating the first side; and covering the adhesive coating with a removable backing.

[00028] Also described herein are garments made using the elastic electrical connectors described herein. For example, a garment may include: a first fabric; a plurality of electrical components on the first fabric; and at least one elastic electrical connector comprising: an elongate strip of a second fabric substrate having a first side; a plurality of wires extending along a length of the first side of the elongate strip of fabric substrate in a sinusoidal or zig-zag pattern, wherein each of the wires is electrically insulated, and wherein the plurality of wires are attached to the first surface by a stitch at a peak and a

trough of the sinusoidal or zig-zag pattern, and an adhesive coating the first side; wherein the each electrical component is connected to one or more wire in the at least one electrical connector. In general, the electrical components described herein that may be connected by the elastic electrical connectors may include any appropriate electrical component, and in particular (but not limited to) a sensor.

- 5 [00029] A method of forming a garment may include: adhesively attaching one or more elastic electrical connector to a first fabric, each elastic electrical connector comprising: an elongate strip of a second fabric substrate having a first side; a plurality of wires extending along a length of the first side of the elongate strip of fabric substrate in a sinusoidal or zig-zag pattern, wherein each of the wires is electrically insulated, and wherein the plurality of wires are attached to the first surface by a stitch at a
10 peak and a trough of the sinusoidal or zig-zag pattern, and an adhesive coating the first side; and attaching a plurality of electrical components to the first fabric, wherein each electrical component is connected to at least one wire of the one or more elastic electrical connector.

BRIEF DESCRIPTION OF THE DRAWINGS

- 15 [00030] FIG. 1A is a schematic illustration of an elastic electrical connector device for incorporating into a garment to connect multiple electrical components in the garment, shown in a top view. FIG. 1B is a side view of the electrical connector shown in FIG. 1A.

[00031] FIG. 2 illustrates a roll of elastic electrical connector such as the connector shown in FIG. 1A.

- 20 [00032] FIG. 3 is a schematic illustration of another example of an elastic electrical connector for use in connecting multiple electrical components to a garment.

[00033] FIG. 4 shows one example of a bundle of insulated (enameled) wires of an elastic electrical connector connected on one side of a fabric material forming an elastic electrical connector.

- 25 [00034] FIG. 5 is another example of a bundle of insulated (enameled) wires of an elastic electrical connector connected on one side of a fabric material forming an elastic electrical connector.

[00035] FIG. 6 illustrates the use an elastic electrical connector such as those described herein to electrically connect with an electrical component (e.g., a printed circuit board, or PCB, of a UART BUS).

[00036] FIG. 7 illustrates the use an elastic electrical connector such as those described herein to electrically connect with another electrical component (e.g., an external connector).

- 30 [00037] FIG. 8 illustrates the use an elastic electrical connector such as those described herein to electrically connect with an electrical component (e.g., a strain gauge).

[00038] FIG. 9 illustrates the use an elastic electrical connector such as those described herein to electrically connect with an electrical component (e.g., electrodes).

- 35 [00039] FIGS. 10A-10C illustrate data characterizing the electrical properties and behavior of one example of an elastic electrical connector as described herein. FIG. 10A is a graph showing test results illustrating the voltage through wires of a flexible (fabric) connector having four wires, over repeated cycles of stretching (up to 3000 cycles). FIG. 10B graphically illustrates an example of a connector having six wires. FIG. 10C illustrates an example of a connector having 8 connectors.

[00040] FIG. 11 is a schematic section through a bundle of six insulated (enameled) wires that may be used to form an elastic electrical connector.

[00041] FIG. 12 is a schematic section through a bundle of four insulated (enameled) wires that may be used to form an elastic electrical connector.

5 [00042] FIG. 13 illustrates an elongate strip of fabric configured as an elastic electrical connector.

[00043] FIG. 14 shows an enlarged view of the proximal end of the elastic electrical connector device of FIG. 13, showing the ends of six insulated wires forming the wire bundle arranged in a zig-zag pattern along the length of the elastic electrical connector.

10 [00044] FIG. 15A is an enlarged view of a stretch sensor such as the one shown in FIG. 8, electrically connected to two of the wires of an elastic electrical connector.

[00045] FIG. 15B shows another view (enlarged) of a region of a stretch sensor similar to the one shown in FIG. 15A with the inside exposed; FIG. 15C shows the sensor of FIG. 15B with a cover attached.

15 [00046] FIG. 16 is an example of an elastic electrical connector shown connected to multiple electrical components, including a body ground pad, ECG electrode, and breath sensor. Additional electrical components may also be added.

20 [00047] FIGS. 17A-17F illustrate assembly of an electrode sensor. These figures are showing the new electrode assembly (in this case is the EMG electrode). Take note that this new structure is common to all of our electrodes and basically it is made applying, by thermal process, the ink sensor on a fabric base (not elastic) with glue film (the same of the ribbon) on the other side. This "multilayer" gets holed, then the rivet is inserted in the hole.

[00048] FIG. 18 illustrates machining of an electrode sensor by riveting a connector in contact with a conductive ink forming the sensor.

25 [00049] FIG. 19A and 19B show an EMG electrode. FIG. 19A shows the front (wearer-facing) surface, while FIG. 19B shows the back surface that will be attached to the garment. The sensor may be connected to a connector (e.g., a SPIDON as described herein) and then applied to the garment.

[00050] FIG. 20 illustrates soldering of an EMG electrode such as the ones shown in FIGS. 19A and 19B to an electrical connector device by connecting (soldering) at the cap of the attached rivet.

30 [00051] FIG. 21 shows one example of a sensor management system (SMS), including a housing, connected to a fabric (e.g., garment), to which an elastic electrical connector may also be connected.

[00052] FIG. 22 illustrates an assembled SMS connector and housing attached to a fabric (garment).

[00053] FIG. 23 shows a top of an SMS housing.

[00054] FIG. 24 shows a bottom of an SMS housing.

35 [00055] FIG. 25 shows another view of a top of an SMS housing including an epoxy resin for waterproofing.

[00056] FIG. 26 illustrates different housing configurations (e.g., left 20 poles, middle 24 poles, and right 28 poles) for an SMS housing.

[00057] FIG. 27A illustrates a multimedia module device (MMM device) mating with an SMS connector, shown in partial cross-section. FIG. 27B shows the MMM device and SMS connector fully mated.

[00058] FIG. 28 shows a solder layer of an SMS microcontroller.

5 [00059] FIG. 29 shows a component layer of an SMS microcontroller.

[00060] FIG. 30A shows the SMS microcontroller of FIGS. 28 and 29 housed within an SMS housing.

[00061] FIG. 30B shows another example of a housing for an SMS microcontroller.

10 [00062] FIG. 31 is another illustration, similar to that shown in FIG. 6, of an SMS connected to an elastic electrical connector as described herein.

[00063] FIG. 32 illustrates another example of electrodes connected to an elastic electrical connector, similar to that shown in FIG. 9.

[00064] FIG. 33 illustrates an elastic electrical connector connected to a six-pole female connector and a splitter PCB.

15 [00065] FIG. 34 shows four elastic electrical connectors, each electrically connected to the SMS connector.

[00066] FIG. 35A illustrates a system or subsystem (referred to herein as a 'spydon system' or spydon subsystem) including multiple (e.g., 5) elastic electrical connectors that each contain a plurality of conductive wires connected or connectable distally to multiple different electrical components (e.g., sensors) and connected at a proximal end to an SMS connector; this entire network may be adhesively and/or otherwise transferred and connected to a fabric to form a wearable garment.

20 [00067] FIG. 35B is another example of a system (or subsystem) having multiple elastic electrical connectors each containing a plurality of conductive wires connected or connectable to multiple different electrical components (e.g., sensors) and connected at a proximal end to an SMS connector, similar to that shown in FIG. 35A.

[00068] FIGS. 36-39 illustrate an alternative variation of an SMS (FIG. 38) and housing (FIGS. 36, 37 and 39) for the SMS circuitry.

30 [00069] FIGS. 40A-40C illustrate examples of conductive thread sewn into a substrate (e.g., fabric); FIG. 40A shows different patterns of stitches, having different pitches and widths (angles); FIG. 40B shows an example of five parallel conductive threads that may connect to five different sensors. FIG. 40C shows an example of a single conductive thread (wire).

[00070] FIG. 41 illustrates one example of a wired ribbon (an elastic electrical connector) that may be used to connect a stretchable fabric.

35 [00071] FIG. 42 illustrates the attachment of a conductive elastic ribbon formed as shown in above, to a stretch sensor using two wires from the elastic electrical connector.

[00072] FIGS. 43, 44 and 45 illustrate one method of making a sealed conductive ribbon (elastic electrical connector) including a stretch sensor coupled to an elastic electrical connector.

[00073] FIGS. 46-48 show examples of elastic electrical connector that may be adhesively attached to a garment to connect multiple electrical components.

[00074] FIG. 49 illustrates one example of a sensor (e.g., inertial measurement unit or IMU) that may be attached to an elastic connector for a wearable apparatus (garment). In this example, the IMU is
5 attached by multiple wires (eight attachments, four per side, are shown).

[00075] FIG. 50 shows an exemplary connection of a PCB (printed circuit board) and a jack (e.g., female jack connector) to an elastic connector.

[00076] FIG. 51 illustrates an IMU and jack such as those shown in FIGS. 49 and 50 connected to an elastic connector as described herein.

10

DETAILED DESCRIPTION

[00077] Described herein are elastic electrical connector devices for incorporating into a garment to connect multiple electrical components in the garment, methods of making these elastic electrical connectors, garments including elastic electrical connectors and methods of making such garments.

15 [00078] An elastic electrical connector may be referred to herein as an elastic strip connector, a fabric strip connector, or the like. Generally, the elastic electrical connectors described herein may include a fabric substrate (e.g., cut or formed into an elongate strip of fabric substrate). This substrate may be elastic (e.g., it may be made of a stretchable fabric). A plurality of wires may be attached to one side of the fabric, and the plurality of wires may be attached in a sinusoidal (e.g., zig-zag) pattern along the
20 length of the elastic electrical connector. For example, the elastic electrical connector may include a plurality of wires extending along a length of the first side of the elongate strip of fabric substrate in a sinusoidal or zig-zag pattern. The wires may be attached to the substrate by sewing or stitching. In some variations, the wires are attached by adhesive (instead of or in addition to stitching). For example, the plurality of wires may be attached to the first surface by one or more stitches at the peaks and troughs of
25 the sinusoidal or zig-zag pattern.

[00079] In general, there may be spacing between the attachment points at the peak and troughs (e.g., between the stitches) holding the bundle of wires to the substrate in the sinusoidal or zig-zag pattern. This spacing may be greater than 1 mm, 2 mm, 3 mm, 4 mm, 5 mm, 6 mm, 7 mm, 8 mm, 9 mm, 10 mm, 11 mm, 12 mm, 13 mm, 14 mm, 15 mm, 20 mm, etc. (e.g., between about 1 mm and 15 mm); this spacing
30 may be distance between durable attachment sites (e.g., stitches). The spacing between attachment points may along the length of the substrate may vary, or it may be constant. Leaving the bundle of wires (which may be twisted together) may make the wires easier to separate out for attachment to an electrical component as will be described below. Note that even in variations in which the wires are not referred to herein as attached, the wires of the elastic electrical connector may be considered as unattached, as the
35 adhesive may not securely hold the wire(s) to the substrate between the peaks and troughs. In general, any of the variations described herein (unless otherwise specified) may include an adhesive on one or both sides of the elastic electrical connector, including the side to which the zig-zag/sinusoidal wires (wire bundle) is attached.

[00080] In some variations the adhesive may hold (or help hold) the plurality of wires or bundle of wires in the sinusoidal pattern as described. For example, the plurality of wires may be embedded within adhesive that holds (or helps hold) the wires in the sinusoidal (e.g., zig-zag, sawtooth, etc.) oscillating pattern yet allow individual wires to be removed from the adhesive and the substrate individually, e.g., by pulling, for cutting and attaching to an electrical device such as a sensor. In any of the variations including adhesive, the adhesive may help hold the plurality (e.g., bundle) of wires in the oscillating pattern along the substrate while still permitting individual wires to be removed from the side (e.g., back) of the substrate for attachment, leaving the other wires in the oscillating pattern. Thus, the adhesive strength (e.g., tensile or pull-off adhesive strength) of a wire held to the substrate (or within the substrate) may be relatively low, allowing it to be manually removed without damaging the individual wire or disrupting the oscillatory pattern of the other wires on the substrate.

[00081] Each of the wires of the elastic electrical connector may be electrically insulated. In particular, the insulation layer on the wire may be thermo-removable, so that just heating (e.g., by soldering, e.g., greater than 200 degrees C, greater than 250 degrees C, greater than 300 degrees C, greater than 350 degrees C, greater than 400 degrees C, etc.) may remove the insulation from the wire at the heated portion, leaving the rest of the wire(s) insulated.

[00082] For example, FIG. 1 illustrates, schematically, one variation of an elastic electrical connector. In this example, the elastic electrical connector device includes a strip of elastic fabric 109, an adhesive 107, and a bundle of wires 102. Any number of wires (e.g., between 2 and 20, 2 and 19, 2 and 18, 2 and 17, 2 and 16, 2 and 15, 2 and 14, etc.) may be included in the connector device. In this example, the zig-zag/sinusoidal bundle of wires may have an amplitude 105 (from trough to peak) of between about 0.5 to 15 mm (or more, e.g., 17, 18, 19, 20, 21, 22, 23, 24, 25, etc., mm). The stitch length 103, or distance between trough and peak along the wire(s) may be between about 1mm to 15mm.

[00083] The electrical connectors described herein may allow deformation (elongation, twisting, curling, etc.) of the electrical connections. Shortly, this is achieved by embedding a bundle of electrical wire in a fabric sandwich held together by the thermo-adhesive. The thickness of the finished spidon may be important for wearable comfort. For example, the thickness applied may be between about 0.5 and 2 mm. (typically <2 mm).

[00084] Because of the arrangement of the zig-zag (sigmoidal) assembly may have material property advantages. For example, maximum elongation (which is dictated by the mechanical properties of the chosen substrate fabric) may increase. The geometry of the ZIG.ZAG pattern is optimized to ensure maximum elongation of the fabric in the long direction (Zig-zag direction) (i.e., the ZIG-ZAG is not the weak-link).

[00085] The amplitude and stitch-lengths of the patterns used to form the elastic electrical connector. For example, the device (e.g., elastic electrical connector) may be optimized to meet the above constraint and to support 3000 stress cycles, e.g., having a guaranteed elongation: of between about 80% to 400. The values for range of angles between the lines of wire extending between peak and trough of usually between 30 and 110 degrees.

[00086] The substrate used may be any appropriate substrate. For example the material used may be, e.g., Lycra, and other synthetic fibers. For example in some variations the fabric comprises a mixture of fabrics, such as a mixture of a synthetic (e.g., polyester) and another material (e.g. Lycra or elastin), e.g., around 25-40% of elastin or Lycra with the remainder being polyester. The fabric in some ways acts as a
5 limiter, limiting the maximum stretch of connector to the maximum stretch of the fabric used, or less.

[00087] As mentioned, any appropriate glue (adhesive) may be applied to the back of the elastic electrical connector. For example, the adhesive may be applied to a thickness of between about 20 and 300 microns (e.g., between about 80-100 microns, between about 50-200 microns, between about 100-200 microns, etc.)

10 [00088] As will be described in more detail below, to connect a wire to an electrical component, the wire maybe cut and removed from the bundle at the cut end so that it can be electrically connected. The wires may be coded (e.g., color/pattern coded), and the proper wire may be cut (e.g., with a scalpel or scissor) and then when soldered directly; the application of the solder (heat) may remove e.g., by
15 evaporation, the insulation. In general, the wires in the bundle are not fused or enclosed together, but may be secured as a bungle only at the apexes (peaks and troughs) of the sinusoidal pattern, e.g., by a stitch. This may allow the wires to be individually separated and pulled out of the bundle (and out of the stitches holding the pattern, e.g., by pulling the cut end from the bundle, allowing them to be easily identified and attached to an electrical component, such as a sensor or PCB.

[00089] Overall, the strip of fabric forming the device may be cut into fabric strips of any length and
20 width. E.g., strips may generally be between 3-4 cm widths (e.g., as thin as possible). Likewise, the length may be varied. In some examples (e.g., FIG. 2), a roll of elastic electrical connector may be made and cut to order during fabrication of the garments described herein.

[00090] This elastic electrical connectors may also be referred to as fabric ribbons or fabric ribbon
25 connectors, and may include the conductive zig-zag (e.g., sinusoidal) enameled, twisted wires. The purpose of the elastic electrical connector is to deliver signals and electricity in every needed part of a garment. There are numerous advantages to this type of elastic electrical connector: every single wire/conductor can be easily connected to a sensor, an electrode or an electronic board without having to strip the wire's jacket, or remove the fabric protection or others. This is possible because the strand on enameled, twisted wires (composed from 2 to up to more than 8 wires) is sewed on the glued side of the
30 ribbon and can be easily worked on (cut, stripped of protection, welded, attached,...) before being thermally applied to the garment. Therefore only a single simple operation is needed in the production process: removing the cut wire's insulation so that it can be welded to electrodes, sensors or any electronic or electrical parts.

[00091] Moreover, this allows us to prepare the "harnesses" with all the required connections in
35 advance, to test it and to then 'attach' it (the 'harness' or SPIDON assembly) to the garment in one single/efficient/low-cost operation much like is done in the car manufacturing for the electrical distribution. In contrast to other devices and methods for connecting electrical components on a wearable garment, the elastic electrical connectors described herein are relatively thin (e.g., less than 2 mm, less

than 1.9 mm, less than 1.8 mm, less than 1.7 mm, less than 1.6 mm, less than 1.5 mm, etc.). In contrast, other connectors are too thick which may prevent the comfort needed in compression or tight clothes.

Other connectors are also described as woven inside the ribbon, thus the connections can only be done at the beginning or at the end of the ribbons so many different ribbons are needed. Further, it may be very difficult and time consuming to cut the ribbon at the desired dimensions and strip out the wires without damaging them. In some cases the wires may not have insulation, thus they have to be sewed separately limiting the ribbon width to the number of wires, moreover the ribbon risks to generate short-circuit effects when in contact with sweat or rain.

[00092] The fabrication of the conductive ribbon as described herein may start with the coupling of a thermo adhesive film with the fabric: the two coupled materials pass then between two hot metal rollers that melt the glue onto the fabric side. A fabric reel normally has a dimension of 140 cm width and a length of about 70 m: after the glue coupling process, the reel can be cut in smaller reels sized to the desired width (Fig. 1). The ribbon reels come out with fabric on the external side and glue (protected with silicone-paper film) on the internal side.

[00093] Using a special custom designed sewing machine, the conductors strand is sewn over the glue side of the ribbon (FIG. 3) after the protection film is removed. The sewn ribbon has a standard length from 5 up to 8 meters depending on the size of the spool and the capacity of the sewing machine as well as on the number of wires inside the strand being used. Depending on the application, the strand can be sewn in the center of the ribbon (FIG. 4) or on one side (FIG. 5). The center sewing is normally used for UART BUS distribution where a local uP on board of a PCB (FIG. 6) or an external connection (FIG. 7) are needed.

[00094] The side sewing may be used for sensors (FIG. 8, showing a strain gauge) and electrodes (FIG. 9) connections in the copper adhesive pads in order to use the free space of the ribbon for cover and seal the contact area.

[00095] The use of an elastic electrical connector as a garment electrification method has been tested by an external certified laboratory with a cycling test bench machine doing a tensile strength with 20% of elongation to verify the electrical continuity of the conductors. Note that other (e.g., 30%, 40%, 50%, 60%, 70%, 80%, 90%, 100%, etc.) elongations have been successfully tested with similar results as well. FIGS. 10A-10C illustrate these results, which verify that these devices have a surprisingly high reliability and effectiveness.

[00096] Each single screen test has been applied by thermal transfer onto a piece of elastic fabric (same fabric material of the ribbon) with dimensions of 45 x 20 cm. One end of the sample was bound to the frame of the test device, while the other end was fixed to the pneumatic piston. The electric wires of the samples, connected in series each other's, have been connected to the source of direct current power supply through a current-limiting resistor. Potential voltage leak at the ends of the wire was monitored by means of a data logger. The tests have been conducted on three different screen test samples: one with 4 conductors, one with 6 conductors and one with 8 conductors.

[00097] Table 1: TEST PARAMETERS

Distance between jaws	270 mm
Elongation	20 %
Cycle frequency	1 Hz
Number of cycles	3000*
Voltage acquisition frequency	1 Hz

*Note: the number of cycles have been calculated considering one ‘dressing’ and one ‘undressing’ per day, for a product life duration exceeding 4 years (as a comparison standard washing cycles are between 40 and 50 times).

[00098] FIGS. 11 and 12 schematically illustrate cross-sections through six and four strand wire bundles. The wires in this example are all enameled copper wires that are 0.05 mm/8 strands thickness. These wires may each be individually color and/or patterned coded, as indicated by the numeric keys to the right of each figure.

[00099] FIG. 13 illustrates an example of a length of elastic electrical connector, shown as long, relatively thin (e.g., between about 2 and 5 cm) and relatively flat (e.g., less than 2 mm). FIG. 14 shows an enlarged view of just the distal end, with the wires (six are shown) exposed. FIG. 15A is an enlarged view of a portion of an elastic electrical connector shown connected to a sensor, specifically a stretch sensor. In practice multiple electrical components (including sensors, PCBs, microphones, electrodes, speakers, etc.) may be connected by the elastic electrical connectors described herein. For example, FIG. 16 illustrates an elastic electrical connector showing multiple electrical components electrically connected to the wires of the elastic electrical connector.

[000100] FIG. 15B illustrates one example of a method of assembling a strain gauge sensor as described herein, that operates based on stretch of an elastic impregnated with conductive particles. In FIG. 15B, the sensor is configured as a breath strain gauge sensor that is fixed directly to the ribbon band 1509 by two rivets 1511, 1511’.

[000101] In this example, the breath sensor (elastic) is placed, centered and attached to the middle of a fabric strip 1509 as shown. The sensor may be attached by keeping the sensor stable, marking two (or more) holes on the band (e.g., by an awl), punching through the band to form holes of approximately 2 mm diameter and fixing the sensor to the strip with two rivets 1511, 1511’. The rivets may be inserted from the back side of the strip, as shown. Once attached, the sensor may be covered with another layer, as shown in FIG. 15C. In this example, a fabric strip 1519 is attached by applying an adhesive around a perimeter region at one or more locations 1521 (or completely around the edge). This sensor configuration may increase the stability of the sensor, allowing it to work concurrently with the ribbon band forming the sub-assembly (spidon). The lower and upper strips of fabric (e.g., the lower strip forming the ribbon band and the covering strip) may form a pocket in which the elastic sensor may stretch and contract without interference.

[000102] FIGS. 17A-17F illustrate one method of making a sensor that may be connected to the elastic electrical connectors described herein.

[000103] As mentioned above, the connectors described herein may be part of a system including one or more flexible connectors (which may be referred to as a “spidon”), that may connect multiple electrical components, including connecting such components to a Sensor Management System (SMS), having male and/or female connectors with their components. The spidon may be configured as a harness with multiple intelligent strands (e.g., made of twisted enameled multi (2 to 20, 2 to 18, 2 to 16, 2 to 14, 2 to 12, etc.) wires sewed against one side of a fabric strip in a sinusoidal (e.g., zig-zag) pattern, and may include isolating glue. The spidon may connect and therefore include electrodes, sensors, haptic actuators, touch-points and ICs such as microcontrollers and IMUs. A spidon may be designed for garment application where signals coming from multiple sensors, electrodes, touch points and haptic actuators placed in different parts of the garment/body have to be connected to microprocessors placed in different parts of the garment/body and to (an) external devices such as a Multi Media Module device (MMM). The SMS connector is part of the Spidon and may be positioned in the upper center of each shirt, which corresponds to the center between the wearer’s shoulder blades, the place in the human body less sensitive to weight and to touch.

[000104] The SMS may be placed in each shirt rather than in the MMM. This solution increases the cost of the system: rather than buying an MMM with a SMS and use it with many shirts with no SMS, the user now has to buy a MMM without an SMS and use it with many shirts each one having an SMS.

However this solution allows to increase the number of sensors, electrodes, touch points and haptic actuators in the garment without having to increase the size of the male and female connectors on the MMM. Potential users may not wear an SMS with more than 36 pins because its size would become too intrusive and uncomfortable.

[000105] By placing the SMS in the connector glued to the shirt, each sensor, electrode, touch point or haptic actuator may be directly connected to the SMS microprocessor through the already mentioned strands. The SMS microprocessor is then responsible for acquiring and processing each sensor, electrode, touch point or haptic actuator data and signals, and for sending those calculations to the MMM through a digital serial port that requires just two pins on the SMS connector.

[000106] It should be noted that in case the SMS would have been placed in the MMM rather than in shirt connector, all the sensors, electrodes, touch points or haptic actuators would have been connected to the MMM, thus dramatically increasing the number of pins on the connector and, as a result, increasing its overall size. In this case, a high number of sensors, electrodes, touch points or haptic actuators could be achieved only at the cost of a bigger connector size. On the contrary, the chosen solution ensures small connector dimensions and a high number of sensors, electrodes, touch points or haptic actuators (up to forty-four connections or more) at the same time.

[000107] In addition to the already described architecture, additional technology allows the system to increase the number of sensors, electrodes, touch points or haptic actuators without increasing the number of strands that need to be embedded into the garment and connected to the SMS connector. This may be

achieved by using the intelligent dedicated strands that were already mentioned above. These intelligent strands which connect embed sensors, electrodes, touch points, haptic actuators and microprocessors that communicate with the SMS microprocessor in a similar way as the MMM and SMS are. Each bundle may include multiple strands or wires. For example, four twisted enameled wires may be used: two wires to carry signal (e.g., acting as a digital serial communication bus), and two for the power supply and ground.

[000108] Following a similar principle as the one described for the SMS, it is possible to consider additional 'modules', each containing one or more, each additional microcontroller, embedded into intelligent strands can be then connected to a high number of different sensors, electrodes, touch points and haptic actuators placed on the garment. These modules are connected to the SMS by the strands. The microcontroller, in fact, manages not only sensor conditioning, but also digital communication.

[000109] In addition to this first advantage, there are two other important features that should be noted. First, by using this overall system architecture, the number of wires that go around the garment is considerably reduced, because the sensors, electrodes, touch points or haptic actuators are not connected to the SMS but to the microcontrollers, and also because all the microcontrollers can share the same digital serial bus for communicating with the SMS microcontroller. This is possible because each microprocessor is identified by an address, thus it can be uniquely identified while communicating with the SMS. The fact that the number of wires is reduced by this solution, surely improves garment wearability and comfort for the final users. Wearability and comfort is important for wearable computers like ours that operate when in direct contact with a large portion of our skin (entire upper body/shirts, entire lower body/tights, hands/gloves, feet/socks, head/balaclava and more) contrary to computers, smart phones that are used while on desks, in hands or in pockets or intelligent watches or wrist bands that are worn on our wrists.

[000110] It should be also noted that the number of different microprocessors that can share the same digital serial bus is theoretically infinite or very high and limited primarily by the space on the garment and by the computational power of the SMS microcontroller that needs to manage all the microcontrollers placed around the garment (including the interrogation frequency, bandwidth, etc.).

[000111] Lastly, the combination of microcontrollers, sensors, electrodes, touch points or haptic actuators connected to it, allows to create a sort of "smart sensorized node" that can be managed independently from the SMS and can help to distribute the data processing and to relieve the SMS microcontroller processing load.

[000112] Referring to FIG. 21, the connector body (a1) is made off polycarbonate plastic material with an overall thickness of 2mm in order to guarantee shock protection. At the base there is a flat flange (a2) which allows a good stability on the soft plastic layer support (b1) which is hot-melted to the garment fabric (b2). One additional purpose of this flange is to fix the connector to the first plastic layer through an additional layer (b3) which is hot-melted to the flange in order to 'sandwich' the connector to further stabilize it. The final assembling is shown in Fig. 22.

[000113] In FIG. 23, the SMS connector has four magnets (a3) placed at the four corners cylindrical seat (a4) that allows to lock easily and to stabilize the external device to be connected. This connector has a 68 IP grade to be completely waterproof to endure regular washing (it is an 'intelligent' garment thus needs to be regularly cleaned after use), thus the magnets are positioned at the back side of the surface in order to avoid possible oxidation and rust deposit.

[000114] In FIG. 24, despite the matching position between the external device and the SMS connector is constrained, on both sides right and left, is present a semi-cylindrical slot (a5), designed to avoid unwanted reversed connections.

[000115] The connector may also be made waterproof, e.g., or at least water/moisture resistant, as shown in FIG. 25. The female contacts receptacle has been designed to avoid any water access to the inner parts. After the female contacts (a6) insertion in the corresponding pinhole, the back side of the connector is filled with epoxy resin (b4) in order to seal completely any interstice.

[000116] One basic pins configuration is shown in Fig. 24 with 12 poles, but it could also be configured with 16, 20, 24 and 28 poles as shown in the variations of Fig. 26 (showing, 20, 24 and 28, respectively).

[000117] FIG. 27 illustrates the electrical connections between the SMS (Sensor Manager System) connector and the external Multimedia Module device (MMM) are through female contacts (a6) and pogo pins (b5) that thanks to the internal spring ensure stable and reliable electrical contacts even under extreme shocks and vibrations.

[000118] FIGS. 28-31 illustrate an SMS. The SMS shell shown contains a printed circuit board assembly (PCBA) (FIG. 28), directly soldered to the female contacts and acting as a central unit able to acquire and process data and signals from sensors, electrodes, touch points or haptic actuators embedded into the garment and transmit them to the MMM.

[000119] The SMS main component is a microcontroller. As already mentioned, the main purpose of this microcontroller is to manage the acquisition of data and signals coming from sensors (e.g. ECG electrodes, EMGs, string gauges, skin conductance, IMUs, etc.), electrodes, touch points or haptic actuators. The same component is also involved into a first phase of data processing (e.g. digital filters) and into the communication of these calculations to the Multimedia Module through a serial digital line.

[000120] In one example, shown in FIG. 29, twelve pins (female contacts) ensure the electrical connection. These pins are used for having the digital communication, the power supply coming from the Multimedia Module battery (regulated +3.3V and protected VBAT) and other hardware features (e.g. sensing of the connection between Multimedia Module and SMS). In FIG. 30A, the SMS PCBA solder layer has been designed to allow several connections to various types of sensors, electrodes, touch points or haptic actuators distributed throughout the garments to cover the body specific parts (arms, hands, legs, feet, shoulders, head, thorax, back, abdomen, etc.) through a special harness made with elastic ribbon to which is sewed a strand of 2 to 12 (or more) enameled conductors/wires. The strand (bundle of wires) is sewn at the peak and trough of the zig-zag pattern, with each side in this example measuring from a minimum of 2 mm to a maximum of 4 cm and with angles between 1° and 179° in order to allow the

ribbon to stretch from 10% to 500% of its length. The ribbon band is made with the same fabric utilized to make the part of the garment (sleeve, shoulder, etc.) where it is applied. Since stretchable fabrics stretch in various directions (from 1 to 6 or more) the ribbon is applied following the exact stretching direction of the part where it is applied. This process ensures that the ribbon has the same elongation and the same return as the fabric where it is applied to improve functionality (conductivity and data collection) and comfort in wearing the garment. It also improves the looks of the garment (seamless stretching and return of the garment when body is in motion). The elastic ribbon is glued to the stretchable fabric through an adhesive film especially formulated for fabric applications, this adhesive is on the same wiring layer and it is used for hot fixing to the garment's elastic tissue in order to block and keep the zig-zag strand shape after hot application. The zig-zag shape has been optimized to assure the wires elongation during donning and usage avoiding the mechanical stress of the copper conductive material.

[000121] FIG. 30 B is another example of an SMS housing that may be used to secure a controller (SMS controller) that is configured to allow it to securely housing the controller and allow it to interface with a plurality of inputs, e.g., from flexible ribbon connectors, without pulling the wires out of the controller. In FIG. 30B, the SMS connector housing (shell 3009) allows the SMS circuitry (controller, not visible in FIG. 30B) to rest snugly within the housing so that a seal may be provided over the connectors between the wires 3907 and the circuitry. In FIG., 30B, the cover is not shown over the SMS housing; before the back cover is attached, the SMS may be coated with a region of epoxy resin. A sealant 3005 such as a ring of Dow Corning silicone may be placed all around the wires strands collected in the center of the PCB. This silicone 3005 crown may allow the wires exit gently from the SMS connector shell, retained in position, and may also provide some degree of water resistance to the connections.

[000122] In any of the connectors described herein in which the insulated wires are sewn onto the substrate, a separate thread material (e.g., cotton, polyester, blend, etc.) may be used to sew the bundle of wires against the substrate (fabric) at the appropriate regions. A single loop of thread, or multiple loops of thread may be used to hold the wires in place. The thread may pass around the bundle of wires one or more times, and through the substrate one or more times. The stitches securing the wires to the substrate may be separated by a spacing distance (e.g., see FIG. 1, element 103).

[000123] The wired elastic ribbons connect different sensors types as: IMUs, EMGs, electrodes, touch points, ink sensors by conductive washers connections (e.g., FIG. 31), haptic actuators, PCBA (Fig. 10) and any kind of electrical connections.

[000124] In case of PCBA incorporation, this must be previously covered by epoxy resin to prevent any water, sweat or any kind of liquid penetration inside the electronic circuit. The coverage has a smooth and rounded shape in order to have a good touch feeling and an attractive appearance from the external side of the garment.

[000125] The conductive washers may be used for connect the copper wire, soldered on it, to the ink sensors and are made by silver-chloride thin steel film in order to have a strong bending resistance and

good protection against rust and oxidation, maintaining optimal conductivity values. The coupling between the washer and the ink surface is made thanks a special conductive adhesive named z-axis (manufactured by 3M) that allows transmission of electrical signals between the two different material surfaces.

5 [000126] With this system, it is possible have also input/output electrical connections, like connectors or external modules in every parts of the garments thanks to the “splitter PCB” (SPP) that allows the connection of the thin enameled conductor to standard harnesses. As per the PCBA, the SPP must be protected by epoxy resin coverage after cabling. FIG. 32 illustrates a connector electrically connected to a pair of electrodes.

10 [000127] All the wired ribbons terminations are soldered to the SMS PCBA pads on the Solder layer and, after test, are incorporated by epoxy resin inside the SMS connector shell (Fig. 33) in order to completely prevent water penetration. A Spidon subsystem (e.g., FIG. 34, FIG. 35) may then be ready to be coupled with the garment. First of all the SMS connector may be inserted through a slot present on the high back side of the shirt and mechanical fixed to the garment as described above (e.g., FIG. 21), then
15 following the draw projected by a laser projector, the various wired strips may be positioned to the right place of the internal garment surface and using a hydraulic press for thermo printing, fixed to the tissue.

[000128] FIG. 35B illustrates another example of a subsystem including a plurality of elastic electrical connectors that each include a plurality of wires arranged and attached as described herein (e.g., including a plurality of wires extending along a length of a first side of an elongate strip of fabric substrate in a sinusoidal or zig-zag pattern, wherein each of the wires is electrically insulated, and wherein the plurality of wires are attached to the first surface by a stitch at a peak and a trough of the sinusoidal or zig-zag pattern). In this example the subsystem includes seven branches (strips) that all connect at one end (a proximal end) to an SMS controller 3505 (held in an SMS housing). Each branch may include one or more sensors 3517 and/or IMUs 3515 (which may, e.g., process data from the one or more sensors and
20 prepare it for transmission to and by the SMU 3505). The strips forming the subsystem may then be attached or otherwise integrated into a garment (sewn, glued, embedded, layered, attached, etc.), such as a shirt, e.g., a t-shirt having long or short sleeves, including but not limited to compression garments. In FIG 35B, the subsystem includes connectors for a left 3507 touch sensor, a right touch sensor 3507', a left arm 3509, a right arm 3509', a left back 3511, a right back 3511' and a center back region 3513. The
25 different connectors may have different lengths and may connect to different components, as illustrated.

[000129] Other examples of SMS and SMS connectors are shown in FIGS. 36-39.

[000130] FIGS. 40A-40C illustrate other examples of flexible connectors having a wires attached in a sinusoidal or zig-zag pattern. In these example, one or a bundle of fibers is attached (including sewn into the fabric, rather than using an additional thread to sew the wires onto the substrate as described above in
30 FIGS. 1-39). Thus, these embodiments may not have all of the advantages, including ease of removing and connecting a wire, as described above.

[000131] In some variations it may be useful to use conductive threads or other high-conductivity connectors, such as those shown in FIG. 40A-40C. In this example, the conductive thread is stitched onto

the garment in a wavy (e.g., zig-zag, sigmoidal, etc.) pattern that allows some stretching in the net direction of the stitching. As described above, respiration (sensors) traces may be formed of stretchable conductive ink patterns to take advantage of the change in conductivity with the change in resistivity with stretching of the conductive ink pattern. In this example, the sewn pattern of threads includes an

5 approximately 35-40 degree zig-zag pattern allowed the stitch to elongate slightly with the fabric. In some example, the conductive thread is a metallic conductive thread. The angle formed at each turning point (in the wavy pattern) and the width of the pattern may depend upon the textile used. In general, the higher the stretchability of the textile, the smaller the angle. The number of threads may vary; in general, any number of threads may be used depending, for example, on the number of sensors and their pins that

10 need to be connected. The threads are typically sewn directly on the garment. The electrical insulation of the thread may be obtained by an external coating on the thread (e.g. silicone, polyester, cotton, etc.) and/or by a layer of insulating adhesive, as described above. The thread connectors may also be used as part of a transfer as described above. For example, a conductive thread may be sewn on a band made on the same fabric of the garment and then transferred by a thermal process to the garment, e.g., using a layer

15 of adhesive.

[000132] One or more conductive threads may be applied directly to a fabric (such as a compression garment) or to a transfer (e.g., patch of fabric or other material that is then attached to the garment). Conductive threads may be insulated (e.g., enameled) before being sewn. In some variations the conductive thread may be grouped prior to sewing onto a fabric or other substrate. For example, a

20 plurality (e.g., 2, 3, 4, 5, etc.) of threads may be insulated and wound together, then stitched into a substrate, such as the compression fabric. For example, in one variation, an apparatus includes a garment having an IMU and two EMGs with inputs fed into circuitry (e.g., microchip) on the apparatus, including on a sensor module/manager. The components may be operated on the same electronic 'line', where the line is a plurality of electrical conductive threads that are combined together for stitching through the

25 substrate. In one example, two microchips can be operated by the same 'line' made of 4 wires, where each wire is electrically isolated from each other. In stitching a material, the stitch may be formed of two sets of wires; one on top of the substrate and one beneath the substrate, as is understood from mechanical sewing devices; in some variations a stitch formed of conductive thread may include an upper conductive thread (or group of conductive threads) and a lower conductive thread (or group of conductive threads),

30 where the upper conductive thread(s) is primarily on the upper surface and the lower conductive thread(s) are primarily on the lower surface (but one or either may pass through the substrate to engage with the other).

[000133] For example, a conductive thread may include a very fine (e.g., 0.7 millimeters gauge/thickness) 'wire' made of 4 twisted and enameled (thus electrically isolated from each other) wires

35 covered with a binding solution (that is silicon or water based) or protected by a jacket, having a total diameter of about 0.9 millimeters. A conductive wire may be sewn in a wavy (e.g., zig-zag) pattern, such as a pattern having 45 to 90 degrees angles between the legs of the zig-zag, directly on a fabric or substrate. In some example, the pattern is formed on a substrate of material (e.g., fabric) and attached to

the garment. For example, the substrate may be a 1 cm to 3 cm self-adhesive strip of fabric.

[000134] FIGS. 41-48 illustrate the connection and formation of one type of sensor to an elastic electrical connector as described above. In this example, a stretch sensor may be formed by impregnating an elastic material with conductive particles, allowing it to dry and then coupling contacts at the ends, to form terminals. Once the terminals are attached, the elastic material may be coupled to a wire connector, such as the pre-prepared wire ribbon material shown in FIG. 41. In FIG. 41, a wire ribbon material is sewn into a strip of fabric with a pair of twisted wires 1010 (though more than two wires may be used), shown as twisted, enameled (insulated) wires. The wires are sewn into the strip of fabric (e.g., compression fabric) in a zig-zag pattern and the fabric strip may include a fabric adhesive or may be configured for thermally applying to another fabric (e.g., garment), so that the conductive connectors can be applied directly to the fabric without having to sew directly onto the fabric, and providing a covering for the wires. The fabric onto which the wires are sewn is typically the same material to which they are to be applied (e.g., a compression garment fabric). In some variations one side of the fabric onto which the zig-zag pattern of insulated wires is sewn, which may be referred to as an applicator fabric, include or is treated for use with a fabric adhesive (including thermally active adhesive). In practice, long lengths of wire may be prepared ahead of time and cut to need for application to a garment. Note that in general, a wire ribbon material may be used as an electrical connector connecting one or more sensors to other portions of the garments described herein, including a data module, and/or an SMS component. This wire ribbon material may be referred to herein as a wire ribbon material or as a stitched zig-zag connector. This material may be advantageously prepared in long lengths and cut to the desired length for securing (e.g., adhesively securing) the garment and/or sensor.

[000135] For example, in FIG. 42, the conductive elastic ribbon is placed on a thermo adhesive glued surface of the wired ribbon in a region that does not include wire, and connected to the conductive wire ends. For example, as shown in FIG. 43, the conductors (wires) are soldered to the copper terminals.

[000136] Once applied to the conductive wires, the elastic ribbon may be enclosed within a fabric (e.g., an insulating fabric, which may be the same as the fabric to which it's being applied). In some variations the elastic ribbon may be enclosed in an insulator material and/or coated with an insulator. In FIG. 44 and 45 the external side of the conductive elastic ribbon (including the contacts) is sealed with an adhesive tissue ribbon to a width of approximately 33 mm). The tissue (covering) ribbon may be fixed over the elastic ribbon by, e.g., thermo press (when using a thermally activated adhesive) as shown in FIG. 45.

[000137] Thereafter, the resulting ribbon including the conductive elastic material and zig-zag wires may be attached to a garment, such as a compression garment.

[000138] FIG. 49 is an example of a sensor that may be integrated into an elastic connector as described herein. In this example, the sensor is an IMU, although any sensor may be used. Multiple IMUs may be attached to the subsystem (as shown in FIG. 35A and 35B), which may provide body movement and/or positional information when the garment is worn. For example a sensor may be on or part of a printed circuitry board such as the IMU shown in FIG. 49 (or an EMG sensor or conditioning

circuitry). Attachment between a flexible, stretchable fabric and a somewhat more rigid PCB may typically result in a poor connection which may vary in resistance as the wire(s) is/are bent during normal movement/wear of the garment. In FIG., 49, the PADS 4901 onto which the insulated wires of the connector are attached are arranged in a fanned, semi-circular arrangement, so that the wires may remain bundled 4911 until they reach the center of the semi-round seating region (e.g., remain gathered together), as shown, then individual wires spread out and are attached to the contacts (PADS 4911). Similar connections may be made on both ends of the circuitry. In some variations wires that are not connected to the circuit (e.g., sensor) may be separated before reaching the fan-out region at the vertex 4915 of the semi-circular PAD arrangement, and may pass on the strip, around the sensor/circuitry (not shown).

5
10 [000139] FIG. 50 is another example of a circuitry (PCB) that may be connected in a similar fashion to the flexible/stretchable fabric connector strip. In FIG. 50, a female plug 5019 may be connected to the strip. The female jack connector in this example includes two added wings that may improve the Jack connector stability and the fixing to the ribbon. In this example, the insulated wires from the connector strip remain bundled 5011 until they reach a central vertex region 5015, where they then fan out to
15 contact the PAD contacts arranged in a semi-circle that fans out around a common vertex 5015. By connecting the wires of the flexible fabric strip to the more rigid substrate and contacts of a sensor or other PCB (e.g., the connector 5019 shown in FIG. 50) in this manner, stress may be distributed in a way that prevents resistance changes and disconnection of the wires.

[000140] It may also be beneficial to coat the contact region (including the vertex 4915, 5015 and PAD
20 contacts 4909, 5009) with a polymer, such as a silicone. For example, in both FIGS. 49 and 50, a Dow Corning silicone has been placed in the circular seat wire connector regions, keeping the wires in suspension so that they may exit gently from the PCB as a cable boot. The silicone may be accurately and easily applied because of the semi-circular arrangement, and may help insulate and protect from water as well.

25 [000141] In FIG. 51, the sensor (e.g., IMU 5103) and circuitry (processor 5105 with connector 5107) such as those shown in FIGS. 49 and 50 are shown connected to a flexible fabric connector, as illustrated above. In this example, the fabric (e.g., compression or stretchable fabric) 5101 is formed as a strip and has an adhesive on one or both sides (e.g., on the visible side shown in FIG. 51). As just described, both the sensor and the connector, via the circuitry 5105, are attached to some of the wires coupled to the
30 fabric in a zig-zag pattern, as shown.

[000142] When a feature or element is herein referred to as being "on" another feature or element, it can be directly on the other feature or element or intervening features and/or elements may also be present. In contrast, when a feature or element is referred to as being "directly on" another feature or element, there are no intervening features or elements present. It will also be understood that, when a
35 feature or element is referred to as being "connected", "attached" or "coupled" to another feature or element, it can be directly connected, attached or coupled to the other feature or element or intervening features or elements may be present. In contrast, when a feature or element is referred to as being "directly connected", "directly attached" or "directly coupled" to another feature or element, there are no

intervening features or elements present. Although described or shown with respect to one embodiment, the features and elements so described or shown can apply to other embodiments. It will also be appreciated by those of skill in the art that references to a structure or feature that is disposed "adjacent" another feature may have portions that overlap or underlie the adjacent feature.

5 [000143] Terminology used herein is for the purpose of describing particular embodiments only and is not intended to be limiting of the invention. For example, as used herein, the singular forms "a", "an" and "the" are intended to include the plural forms as well, unless the context clearly indicates otherwise. It will be further understood that the terms "comprises" and/or "comprising," when used in this specification, specify the presence of stated features, steps, operations, elements, and/or components,
10 but do not preclude the presence or addition of one or more other features, steps, operations, elements, components, and/or groups thereof. As used herein, the term "and/or" includes any and all combinations of one or more of the associated listed items and may be abbreviated as "/".

[000144] Spatially relative terms, such as "under", "below", "lower", "over", "upper" and the like, may be used herein for ease of description to describe one element or feature's relationship to another
15 element(s) or feature(s) as illustrated in the figures. It will be understood that the spatially relative terms are intended to encompass different orientations of the device in use or operation in addition to the orientation depicted in the figures. For example, if a device in the figures is inverted, elements described as "under" or "beneath" other elements or features would then be oriented "over" the other elements or features. Thus, the exemplary term "under" can encompass both an orientation of over and under. The
20 device may be otherwise oriented (rotated 90 degrees or at other orientations) and the spatially relative descriptors used herein interpreted accordingly. Similarly, the terms "upwardly", "downwardly", "vertical", "horizontal" and the like are used herein for the purpose of explanation only unless specifically indicated otherwise.

[000145] Although the terms "first" and "second" may be used herein to describe various
25 features/elements (including steps), these features/elements should not be limited by these terms, unless the context indicates otherwise. These terms may be used to distinguish one feature/element from another feature/element. Thus, a first feature/element discussed below could be termed a second feature/element, and similarly, a second feature/element discussed below could be termed a first feature/element without departing from the teachings of the present invention.

30 [000146] Throughout this specification and the claims which follow, unless the context requires otherwise, the word "comprise", and variations such as "comprises" and "comprising" means various components can be co-jointly employed in the methods and articles (e.g., compositions and apparatuses including device and methods). For example, the term "comprising" will be understood to imply the inclusion of any stated elements or steps but not the exclusion of any other elements or steps.

35 [000147] As used herein in the specification and claims, including as used in the examples and unless otherwise expressly specified, all numbers may be read as if prefaced by the word "about" or "approximately," even if the term does not expressly appear. The phrase "about" or "approximately" may be used when describing magnitude and/or position to indicate that the value and/or position described is

within a reasonable expected range of values and/or positions. For example, a numeric value may have a value that is +/- 0.1% of the stated value (or range of values), +/- 1% of the stated value (or range of values), +/- 2% of the stated value (or range of values), +/- 5% of the stated value (or range of values), +/- 10% of the stated value (or range of values), etc. Any numerical range recited herein is intended to include all sub-ranges subsumed therein.

[000148] Although various illustrative embodiments are described above, any of a number of changes may be made to various embodiments without departing from the scope of the invention as described by the claims. For example, the order in which various described method steps are performed may often be changed in alternative embodiments, and in other alternative embodiments one or more method steps may be skipped altogether. Optional features of various device and system embodiments may be included in some embodiments and not in others. Therefore, the foregoing description is provided primarily for exemplary purposes and should not be interpreted to limit the scope of the invention as it is set forth in the claims.

[000149] The examples and illustrations included herein show, by way of illustration and not of limitation, specific embodiments in which the subject matter may be practiced. As mentioned, other embodiments may be utilized and derived there from, such that structural and logical substitutions and changes may be made without departing from the scope of this disclosure. Such embodiments of the inventive subject matter may be referred to herein individually or collectively by the term "invention" merely for convenience and without intending to voluntarily limit the scope of this application to any single invention or inventive concept, if more than one is, in fact, disclosed. Thus, although specific embodiments have been illustrated and described herein, any arrangement calculated to achieve the same purpose may be substituted for the specific embodiments shown. This disclosure is intended to cover any and all adaptations or variations of various embodiments. Combinations of the above embodiments, and other embodiments not specifically described herein, will be apparent to those of skill in the art upon reviewing the above description.

CLAIMS

What is claimed is:

1. An elastic electrical connector device for incorporating into a garment to connect multiple electrical components in the garment, the device comprising:
5 an elongate strip of fabric substrate having a first side and a second side;
a plurality of wires extending along a length of the first side of the elongate strip of fabric substrate in a sinusoidal or zig-zag pattern, wherein each of the wires is electrically insulated, and wherein the plurality of wires are attached to the first surface by a stitch at a peak and a trough of the sinusoidal or zig-zag pattern; and
10 an adhesive coating the first side.
2. An elastic electrical connector device for incorporating into a garment to connect multiple electrical components in the garment, the device comprising:
an elongate strip of fabric substrate having a first side with a length;
15 a bundle of wires that are twisted together extending along the length of the first side of the elongate strip of fabric substrate in a sinusoidal or zig-zag pattern, wherein each of the wires is electrically insulated with a thermoremovable insulator, and wherein the bundle of wires are attached to the first surface by a stitch at each peak and trough of the sinusoidal or zig-zag pattern wherein the length between peak and trough stitches is between about 1 mm and 15 mm; and
20 an adhesive coating the first side.
3. The device of claim 1 or 2, wherein the elastic electrical connector device has a maximum thickness of less than about 2 mm.
4. The device of claim 1, wherein the plurality of wires comprises a bundle of wires twisted together.
- 25 5. The device of claim 1 or 2, wherein each of the wires is individually coded along its outer length.
6. The device of claim 1, wherein each of the plurality of wires is electrically insulated with a thermoremovable insulator.
7. The device of claim 1 or 2, wherein each of the wires comprises a copper wire electrically
30 insulated with a polyurethane material.
8. The device of claim 1 or 2, wherein the sinusoid or zig-zag pattern has an amplitude from about 0.5 mm to 15 mm.

9. The device of claim 1, wherein a length between peak and trough stitches is between about 1 mm and 15 mm.
10. The device of claim 1 or 2, wherein the adhesive coating comprises a hot melt film having a low melting point.
- 5 11. The device of claim 1 or 2, wherein the adhesive coating has a thickness of between 10 and 200 micrometers thick.
12. The device of claim 1 or 2, wherein the adhesive coating comprises a hot melt film having a melting point of between about 130 °C and 200°C.
13. The device of claim 1 or 2, wherein the plurality of wires comprises between 2 and 10 wires.
- 10 14. The device of claim 1 or 2, wherein the elongate strip of fabric substrate comprises a stretchable fabric substrate.
15. The device of claim 1 or 2, wherein the elongate strip of fabric substrate comprises a polyamide/elastane blend fabric.
- 15 16. The device of claim 1 or 2, wherein the elongate strip of fabric substrate is between about 0.6 mm and about 3 cm wide and greater than about 10 cm long.
17. The device of claim 1 or 2, further comprises a removable backing on the first side covering the adhesive.
18. The device of claim 1 or 2, further comprises a removable paper backing on the first side covering the adhesive.
- 20 19. An elastic electrical connector device for incorporating into a garment to connect multiple electrical components in the garment, the device comprising:
an elongate strip of fabric substrate having a first side and a second side;
a plurality of wires extending along a length of the first side of the elongate strip of fabric substrate in a sinusoidal or zig-zag pattern, wherein each of the wires is electrically
25 insulated, and wherein the plurality of wires are attached to the first surface; and
an adhesive coating the first side.
20. The device of claim 19, wherein the plurality of wires are adhesively secured to the first side of the fabric substrate by the adhesive in the sinusoidal or zig-zag pattern.
- 30 21. A method of forming an elastic electrical connector that may be applied to a garment to connect multiple electrical components of the garment, the method comprising:

attaching an elongate bundle of wires to a first surface of an elongate strip of fabric in a sinusoidal or zig-zag pattern comprising alternating peaks and troughs, wherein the wires are each electrically insulated, and wherein the bundle is attached to the first surface by at least one stitch at each peak and trough of the sinusoidal or zig-zag pattern, wherein the length between peak and trough stitches is between about 1 mm and 15 mm;

applying an adhesive coating the first side; and
covering the adhesive coating with a removable backing.

22. A garment, the garment comprising:

a first fabric;

a plurality of electrical components on the first fabric; and

at least one elastic electrical connector comprising:

an elongate strip of a second fabric substrate having a first side;

a plurality of wires extending along a length of the first side of the elongate strip of

fabric substrate in a sinusoidal or zig-zag pattern, wherein each of the wires is electrically insulated, and wherein the plurality of wires are attached to the first surface by a stitch at a peak and a trough of the sinusoidal or zig-zag pattern, and an adhesive coating the first side;

wherein the each electrical component is connected to one or more wire in the at least one electrical connector.

23. The garment of claim 21, wherein the electrical component comprises a sensor.

24. A method of forming a garment, the method comprising:

adhesively attaching one or more elastic electrical connector to a first fabric, each elastic electrical connector comprising:

an elongate strip of a second fabric substrate having a first side;

a plurality of wires extending along a length of the first side of the elongate strip of

fabric substrate in a sinusoidal or zig-zag pattern, wherein each of the wires is electrically insulated, and wherein the plurality of wires are attached to the first surface by a stitch at a peak and a trough of the sinusoidal or zig-zag pattern, and an adhesive coating the first side; and

attaching a plurality of electrical components to the first fabric, wherein each electrical component is connected to at least one wire of the one or more elastic electrical connector.

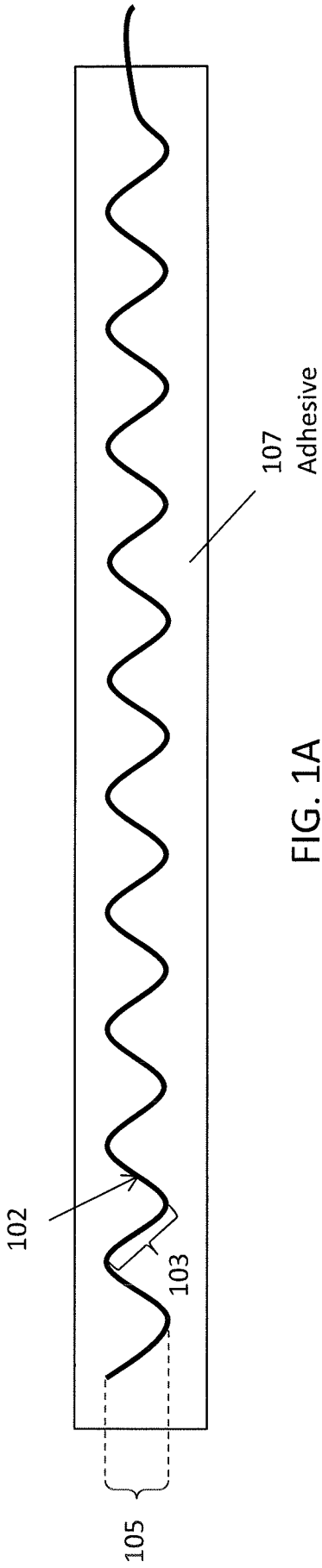

FIG. 1A

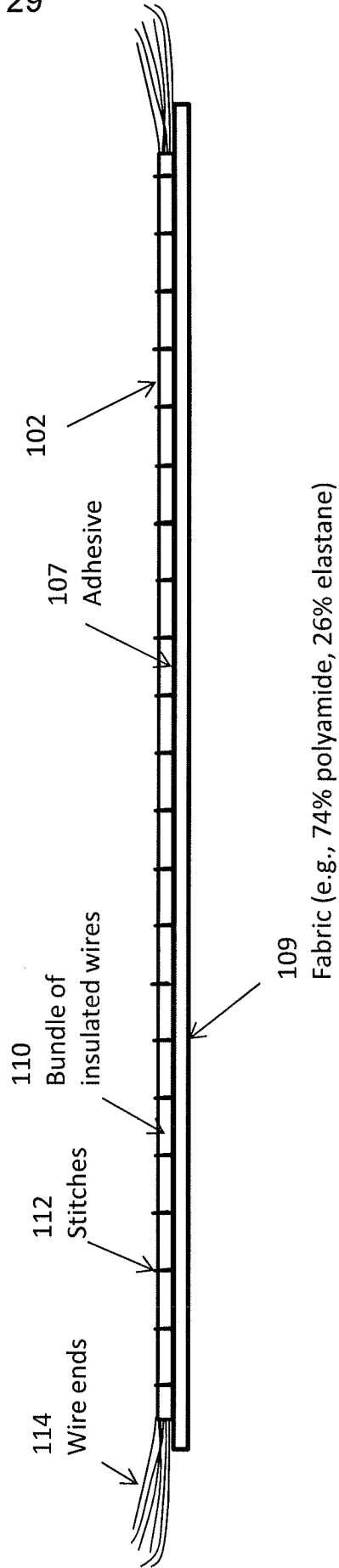

FIG. 1B

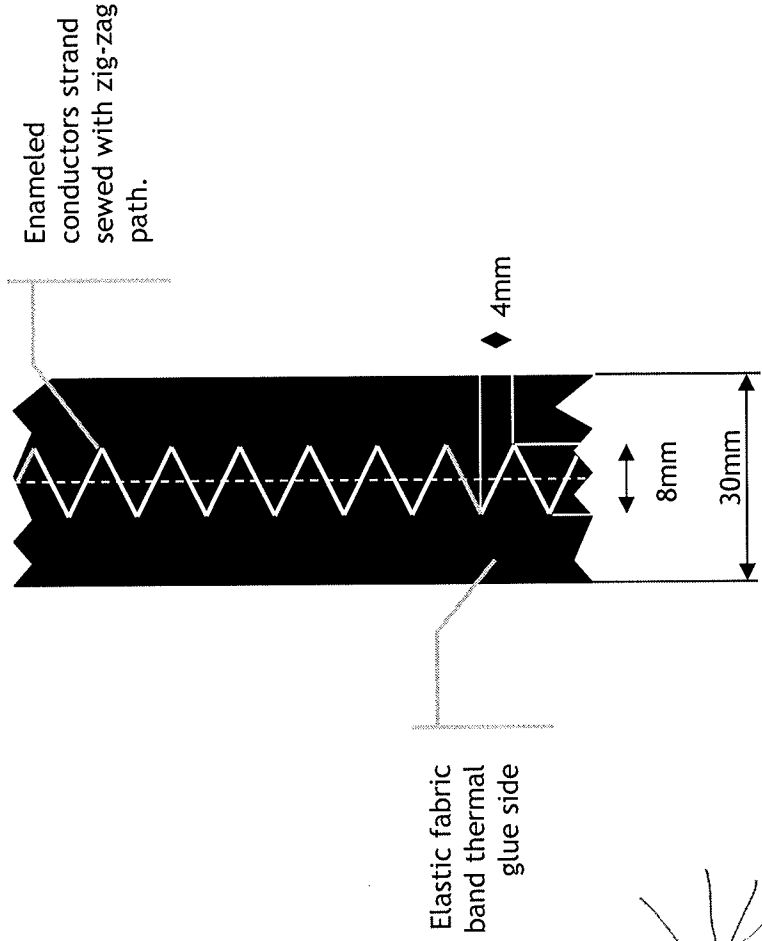

FIG. 3

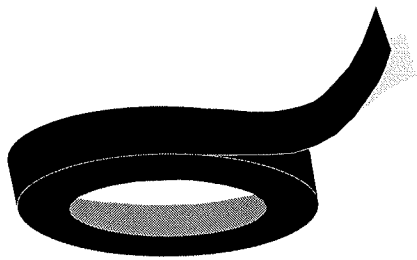

FIG. 2

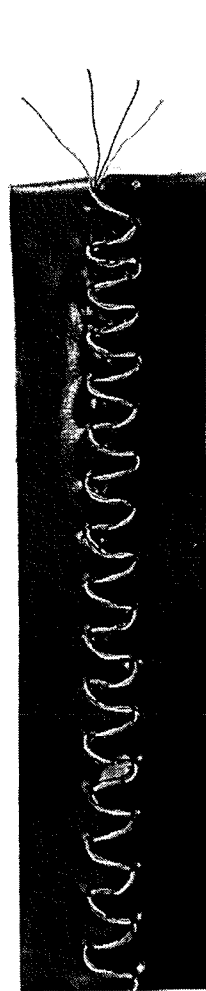

FIG. 4

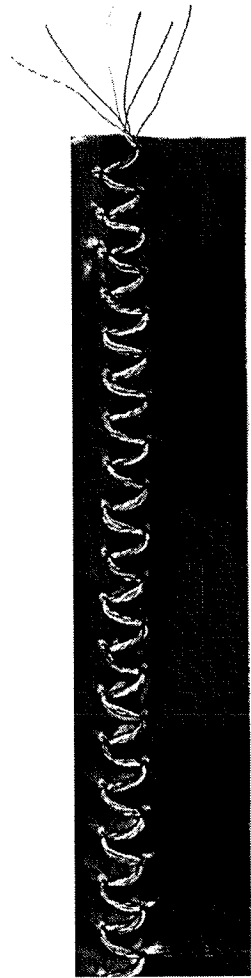

FIG. 5

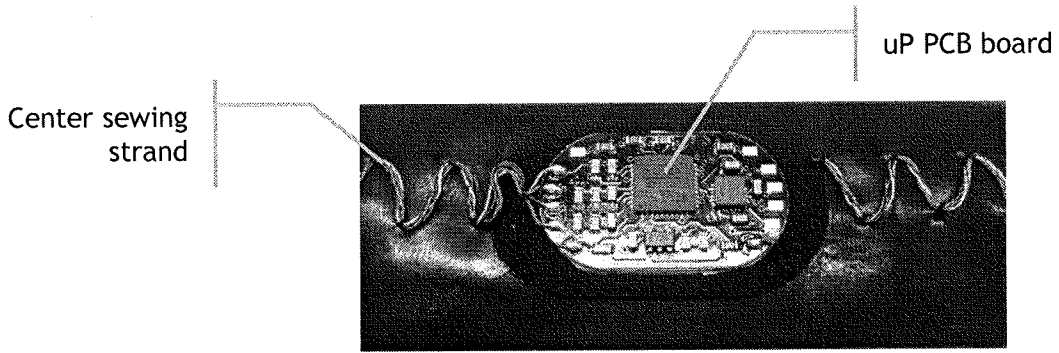

FIG. 6

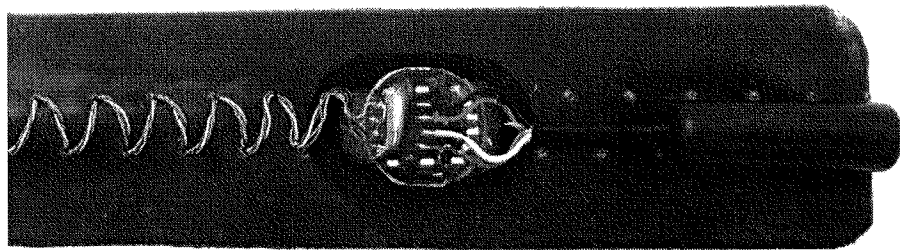

FIG. 7

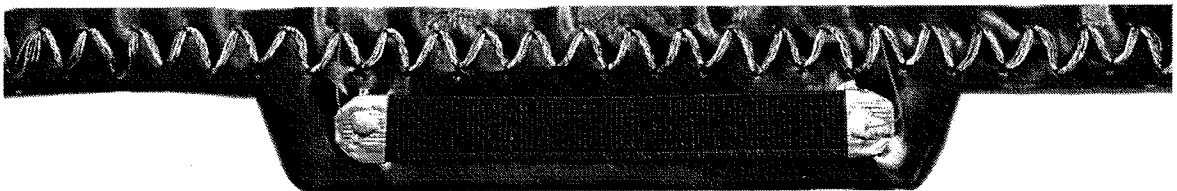

FIG. 8

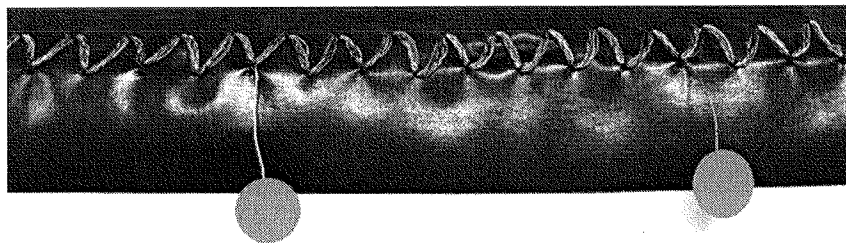

FIG. 9

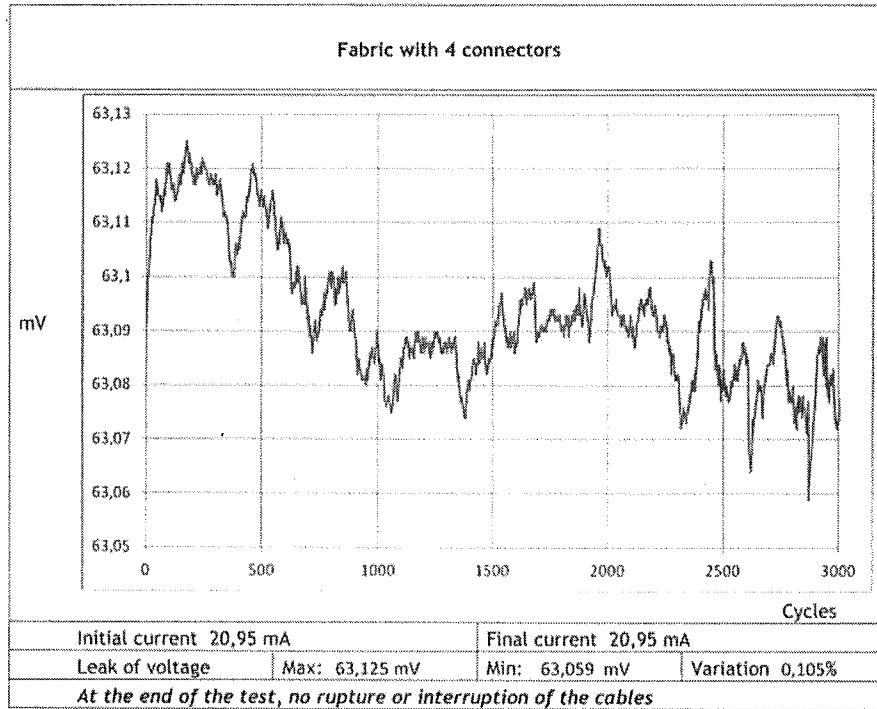

FIG. 10A

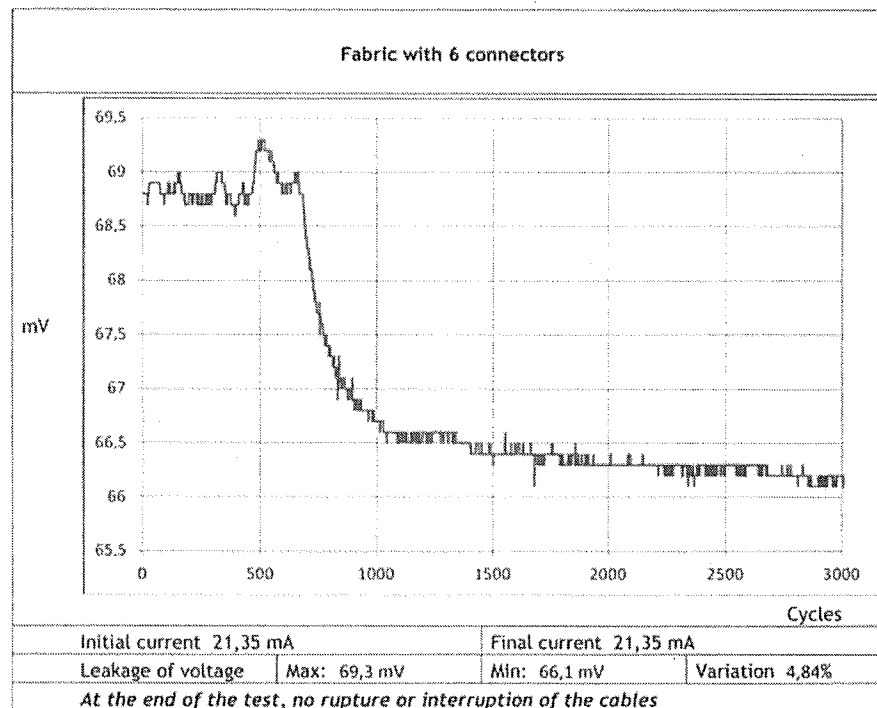

FIG. 10B

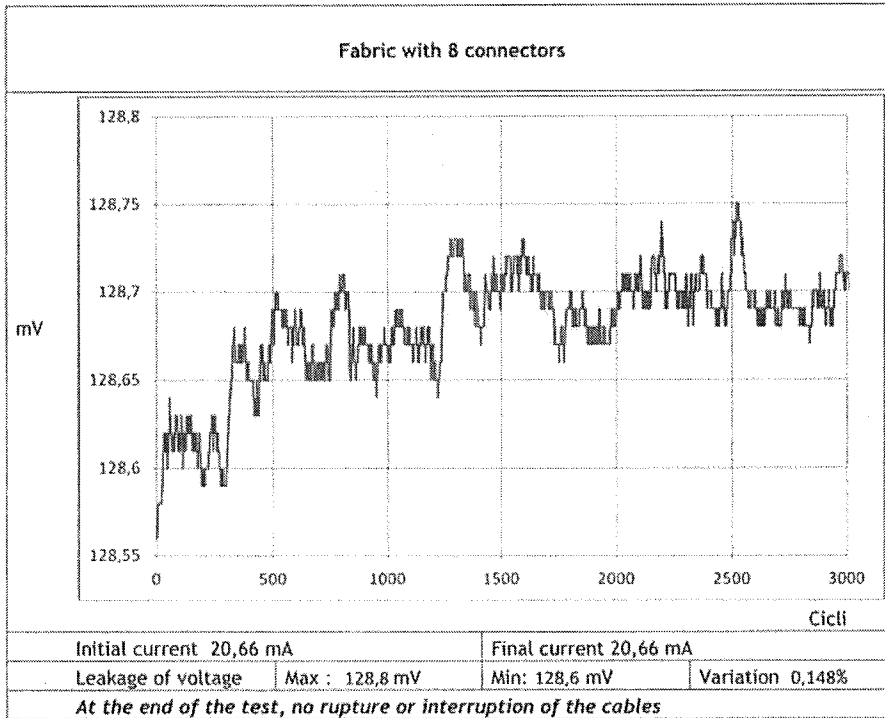

FIG. 10C

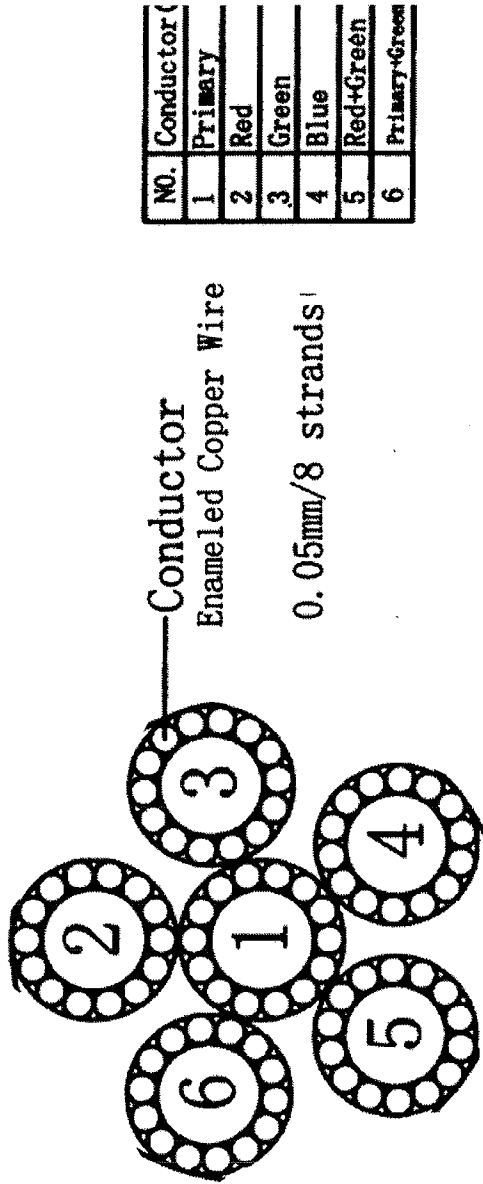

FIG. 11

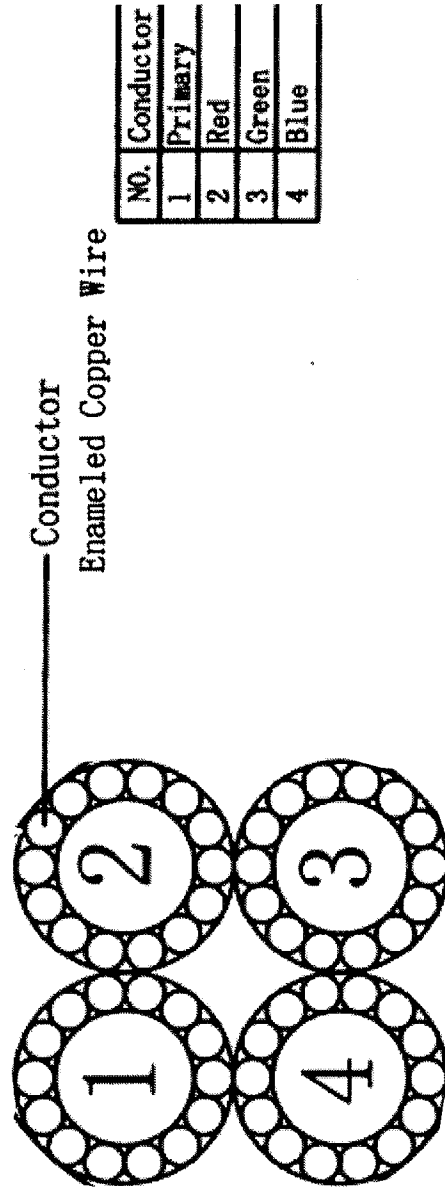

FIG. 12

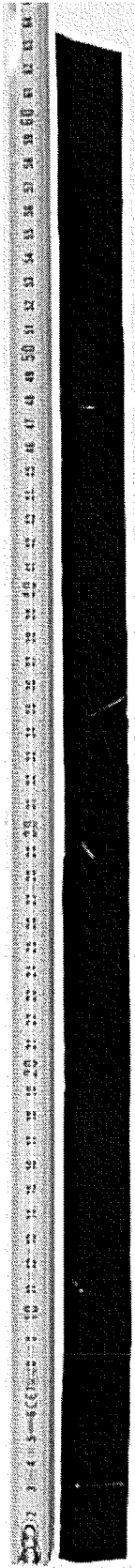

FIG. 13

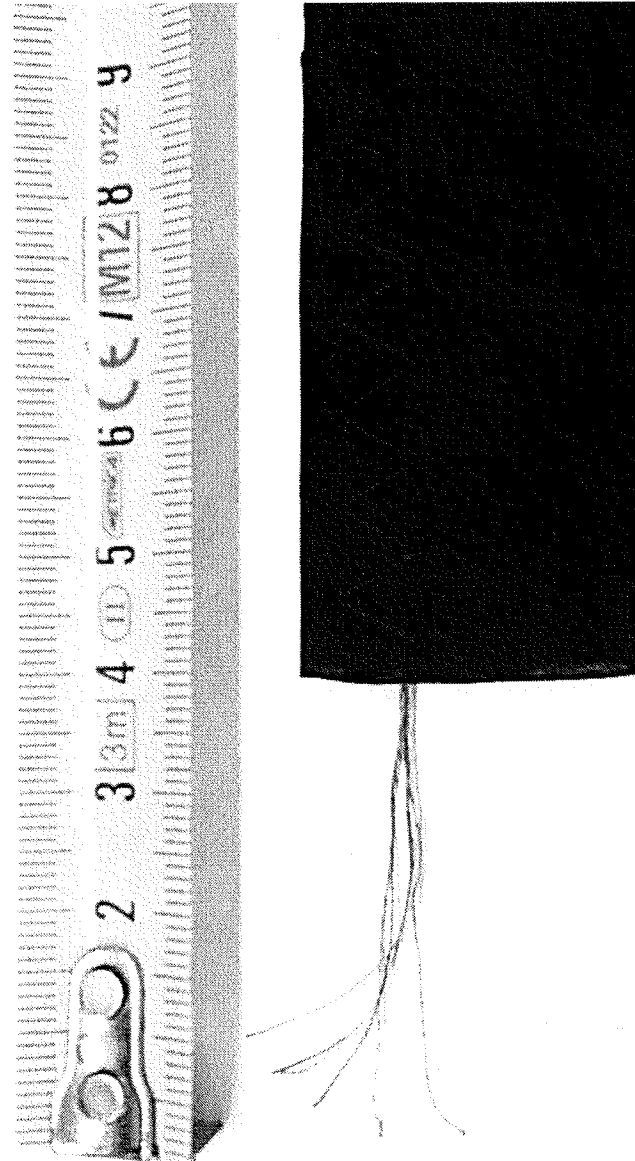

FIG. 14

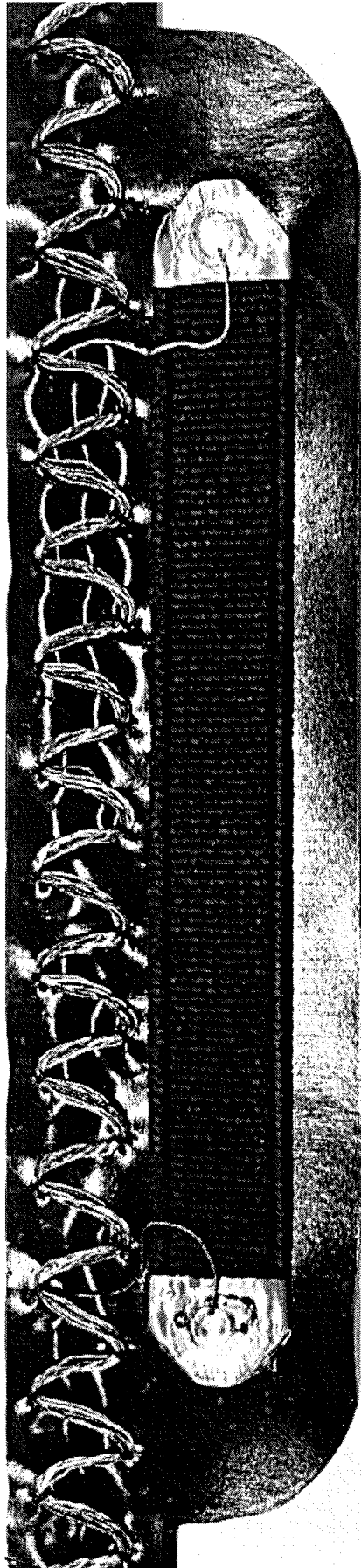

FIG. 15A

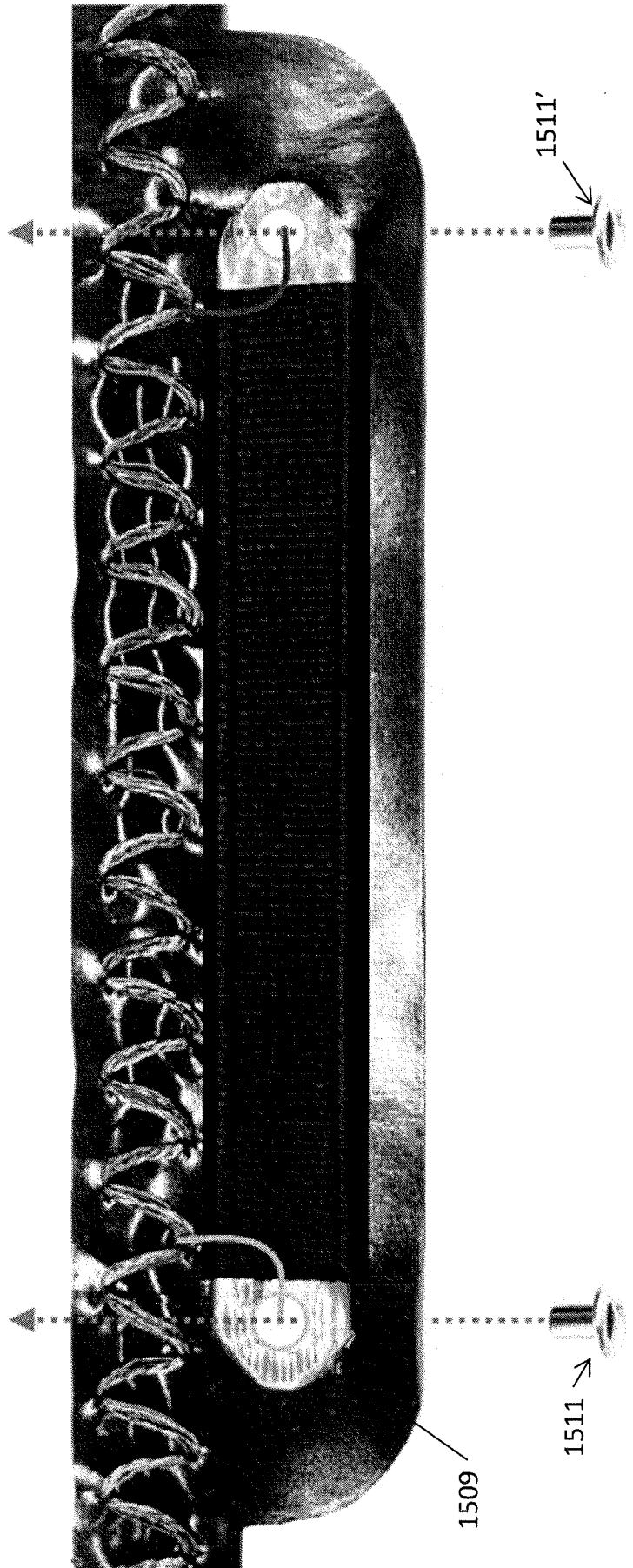

FIG. 15B

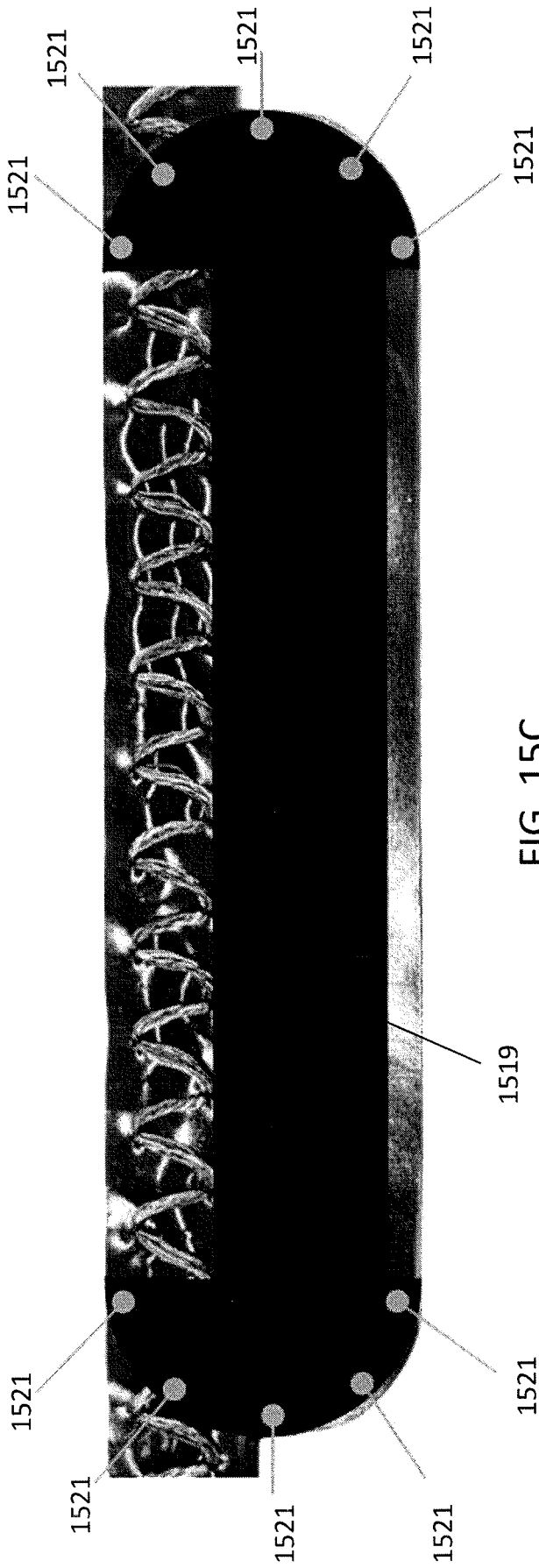

FIG. 15C

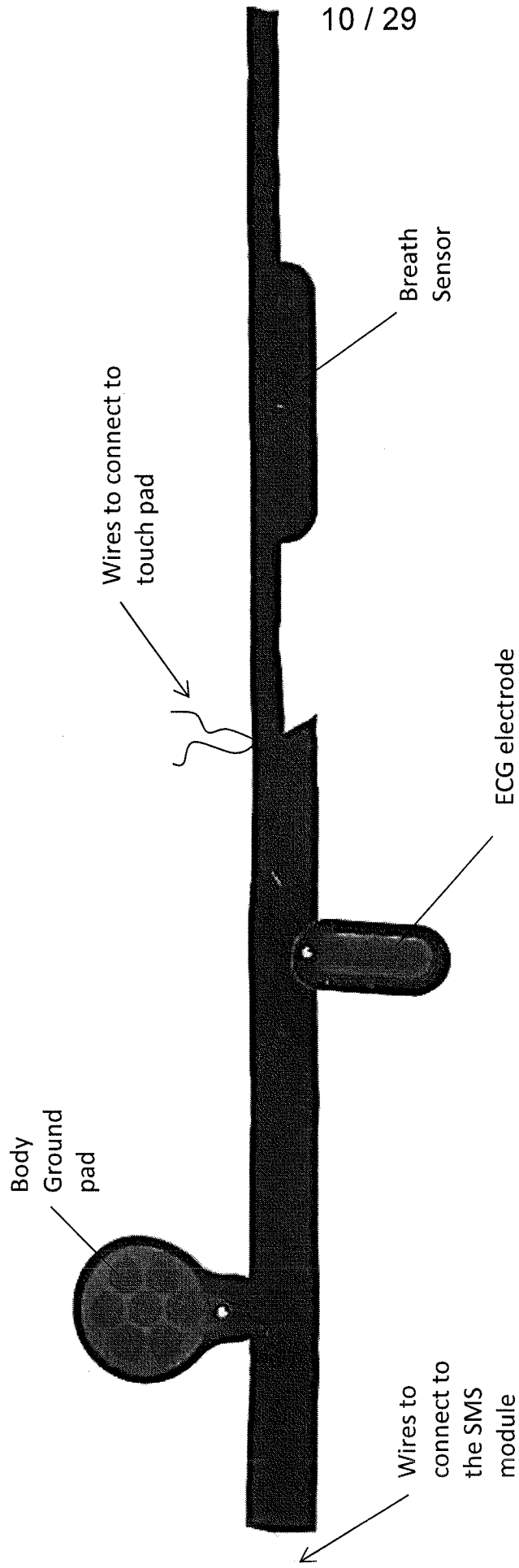

FIG. 16

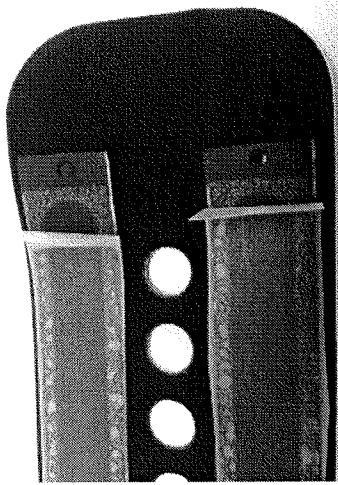

FIG. 17C

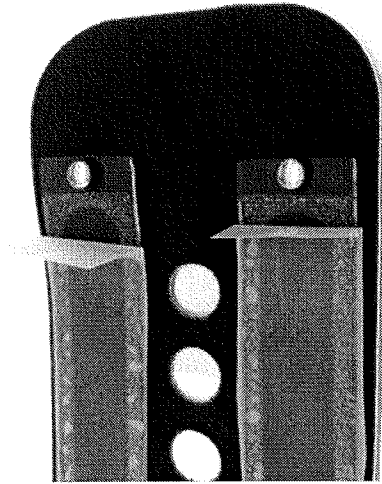

FIG. 17F

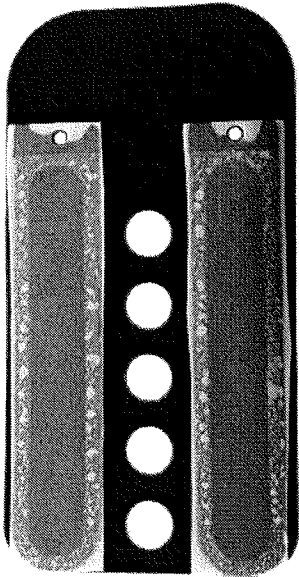

FIG. 17B

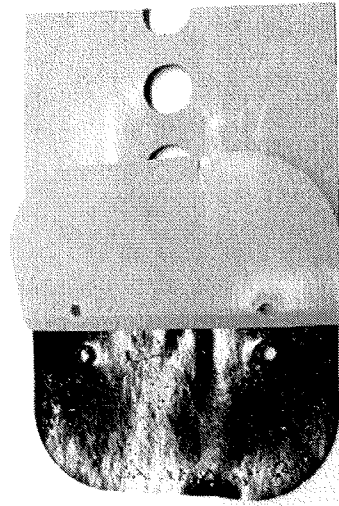

FIG. 17E

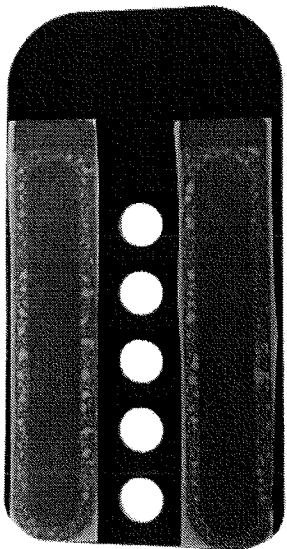

FIG. 17A

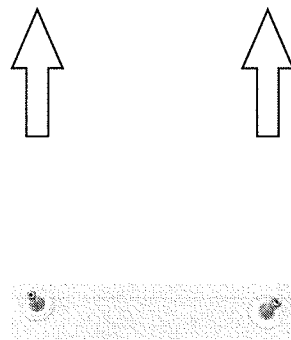

FIG. 17D

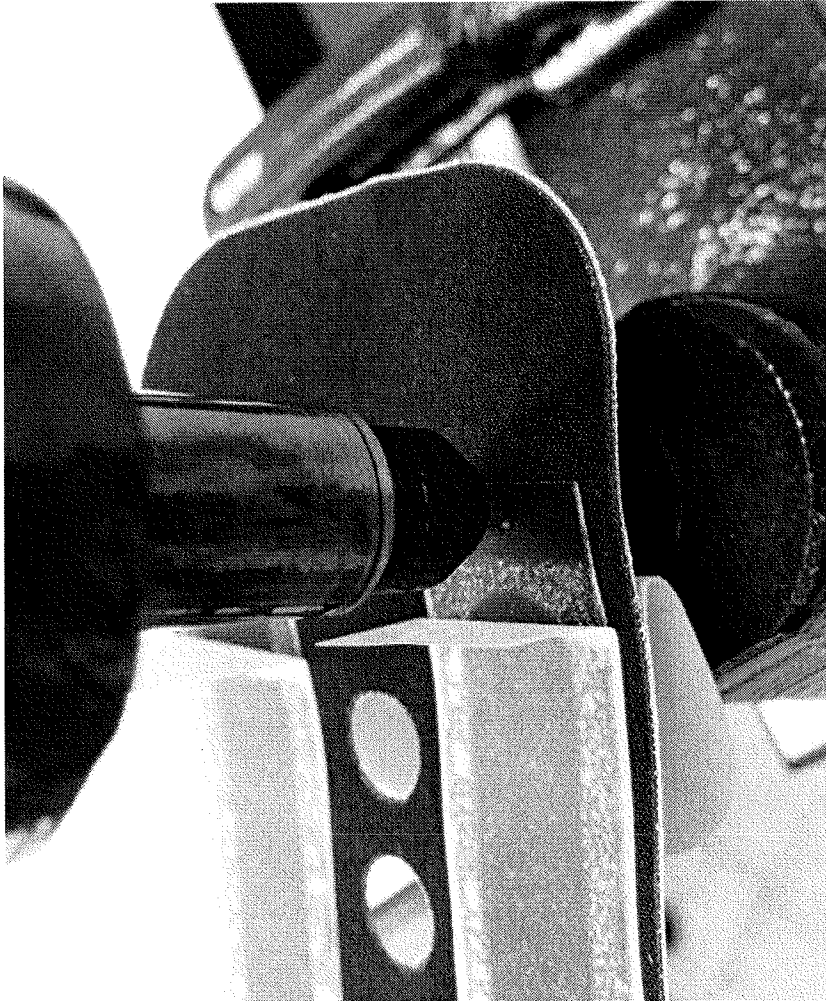

FIG. 18

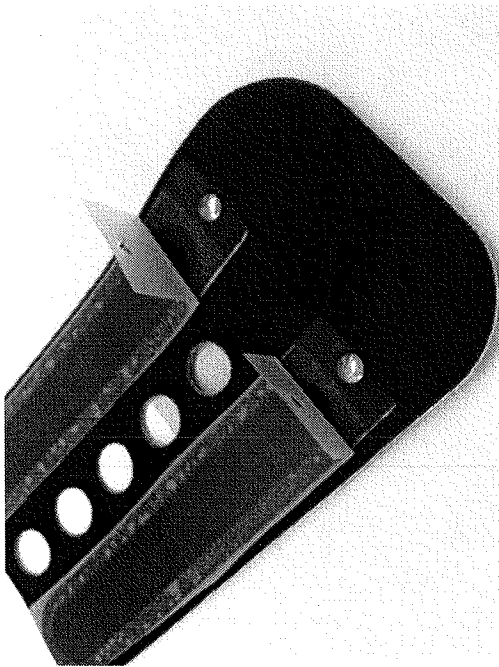

FIG. 19A

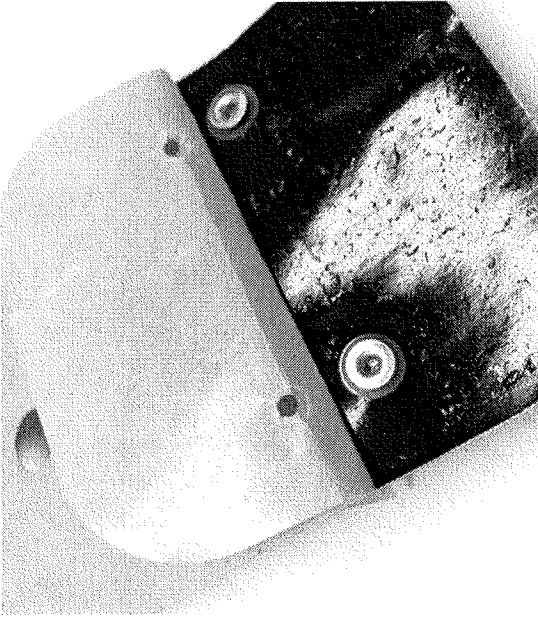

FIG. 19B

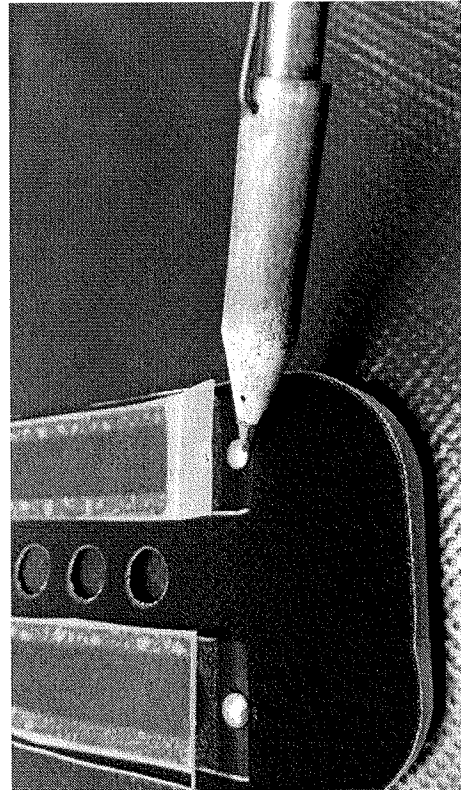

FIG. 20

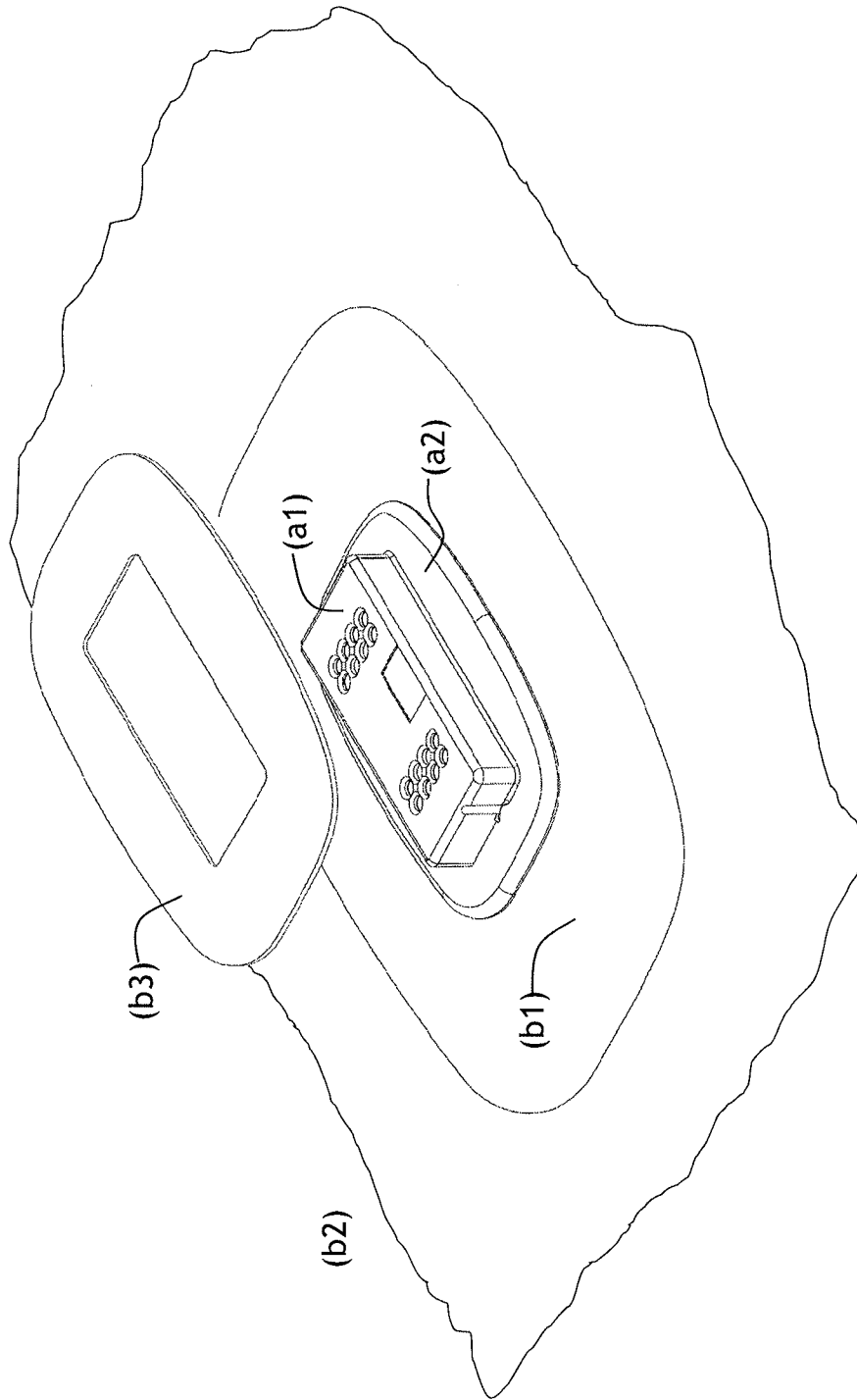

FIG. 21

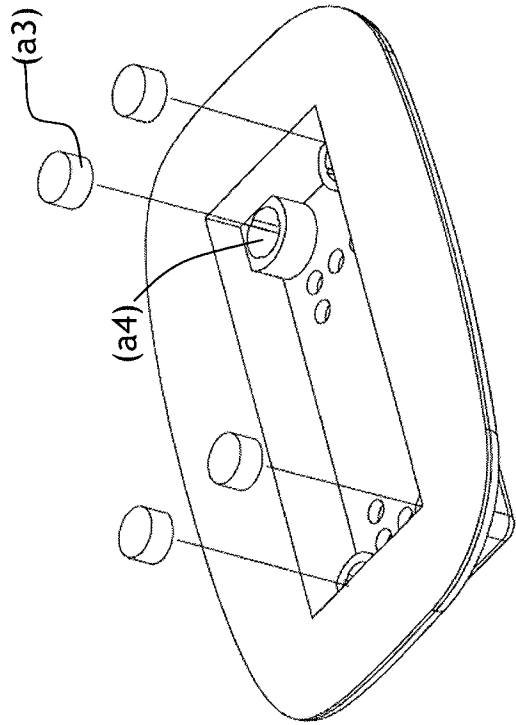

FIG. 23

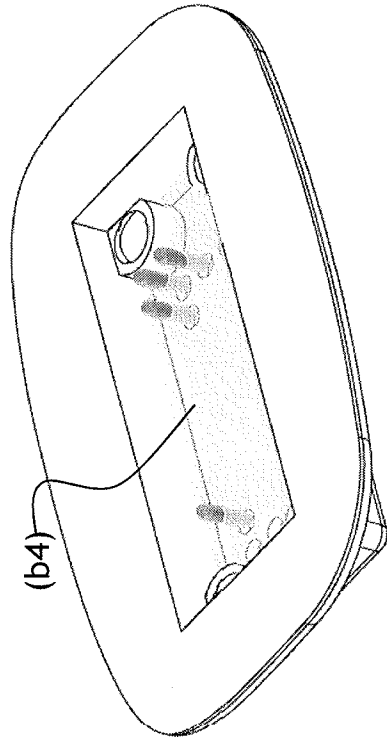

FIG. 25

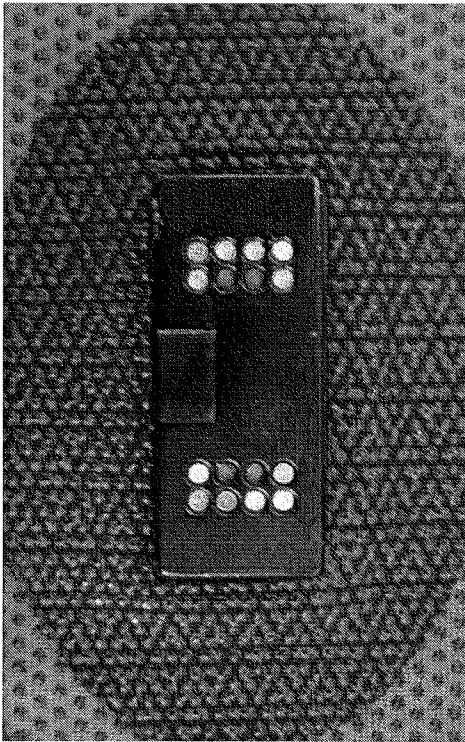

FIG. 22

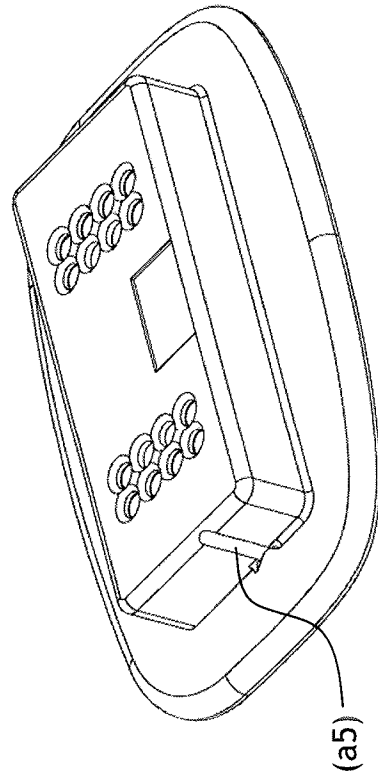
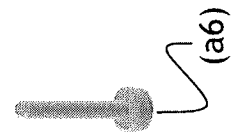

FIG. 24



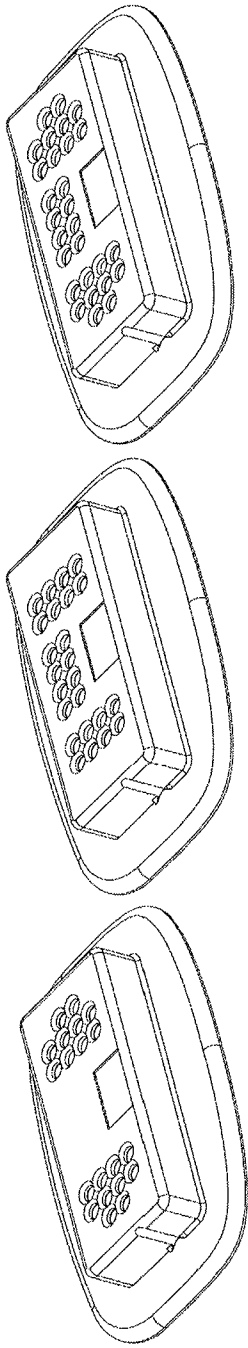

FIG. 26

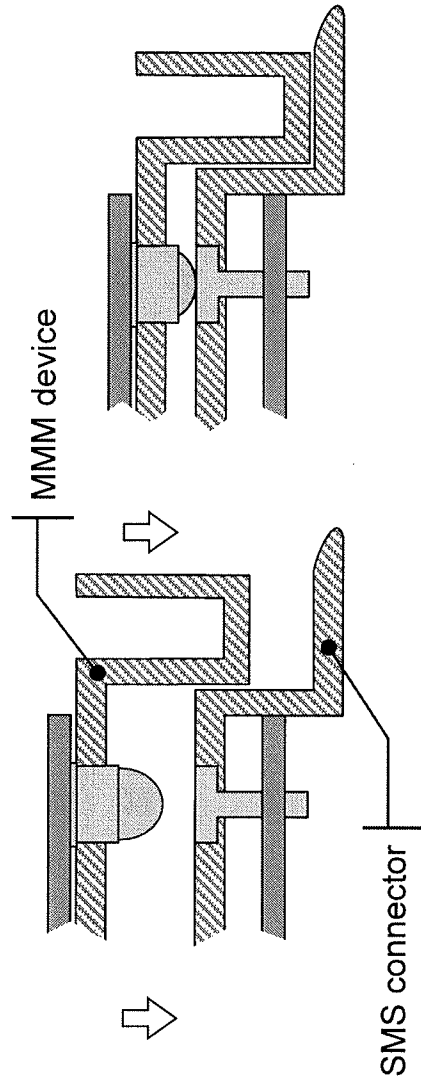

FIG. 27A

FIG. 27B

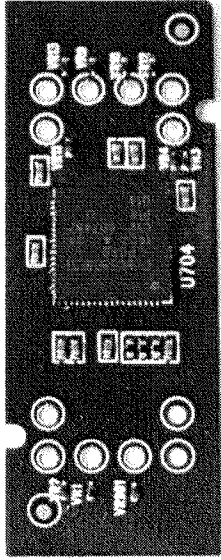

FIG. 29

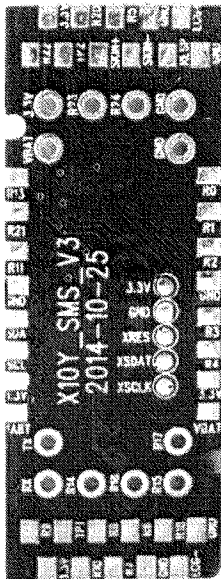

FIG. 28

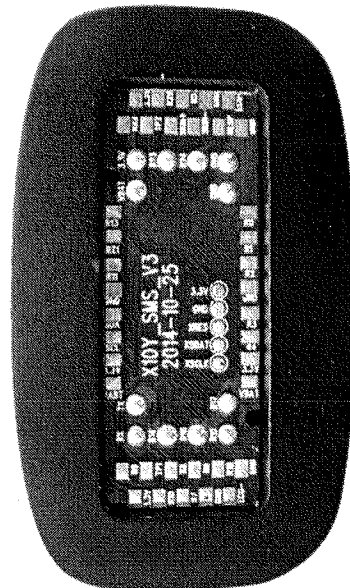

FIG. 30A

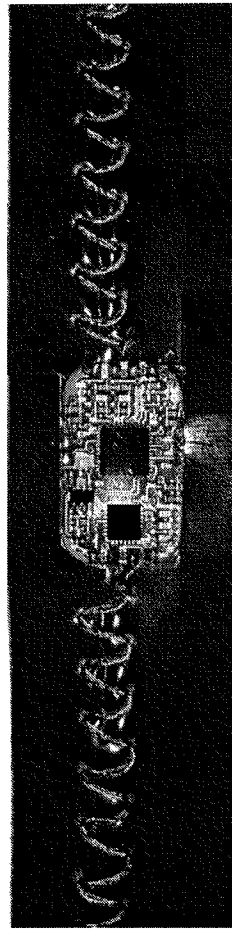

FIG. 31

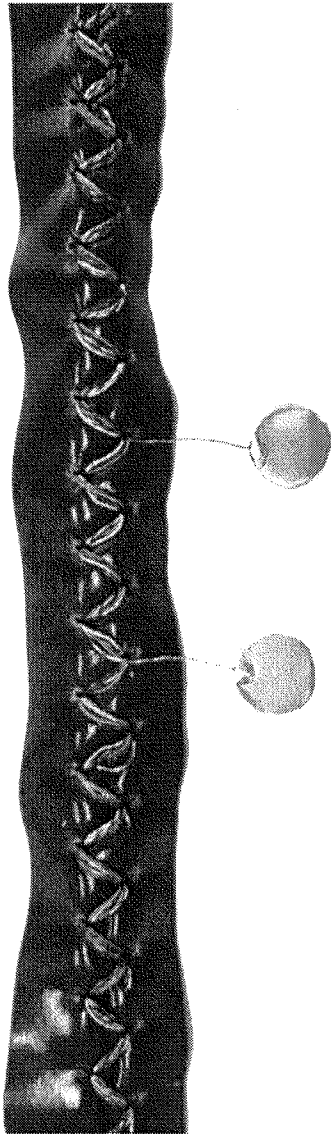

FIG. 32

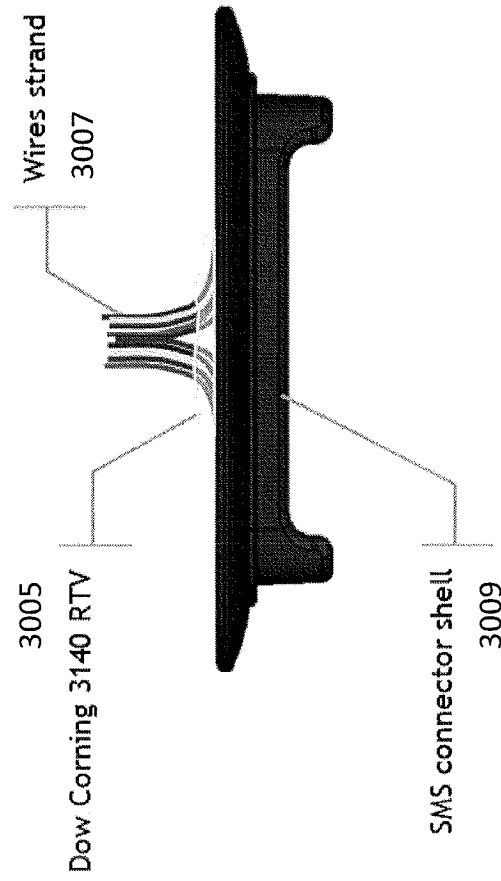

FIG. 30B

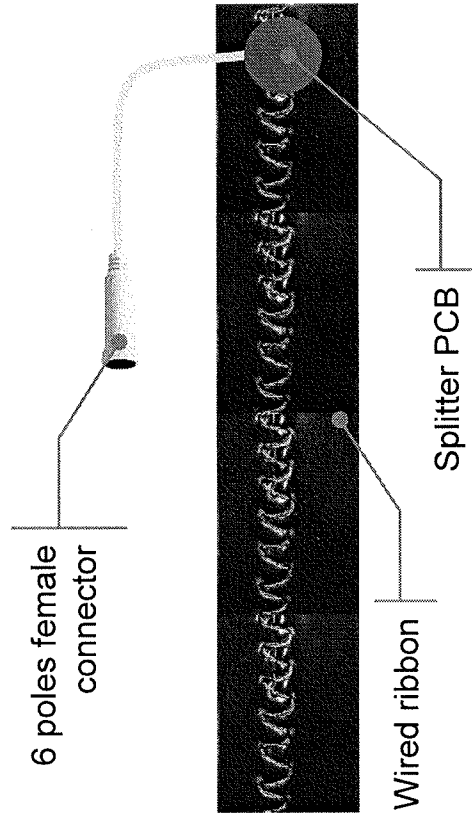

FIG. 33

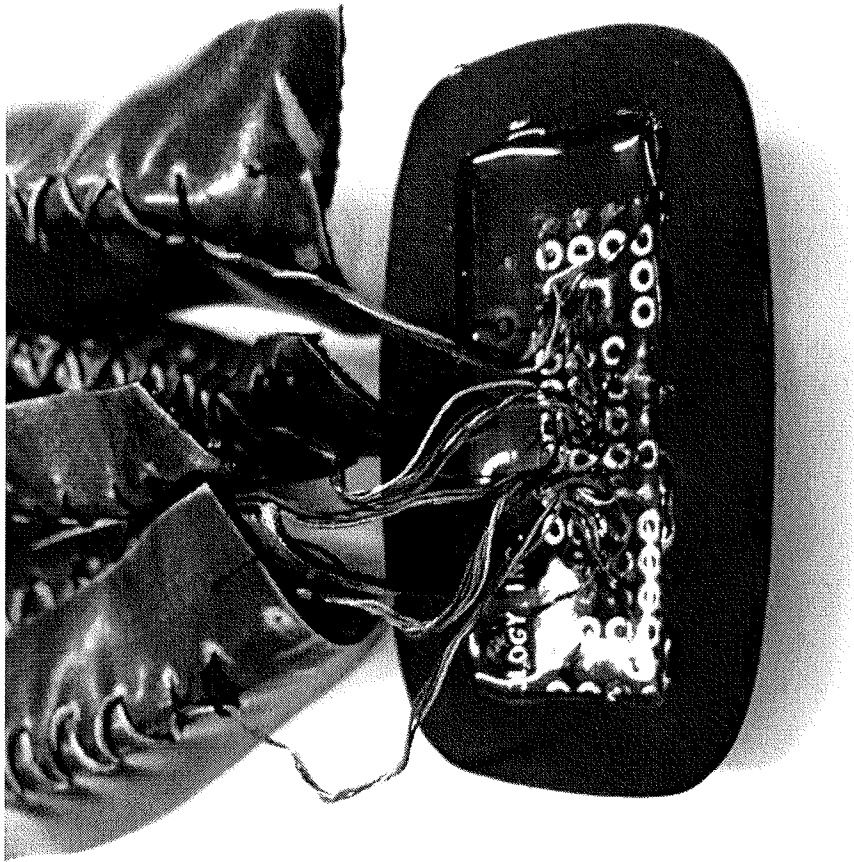

FIG. 34

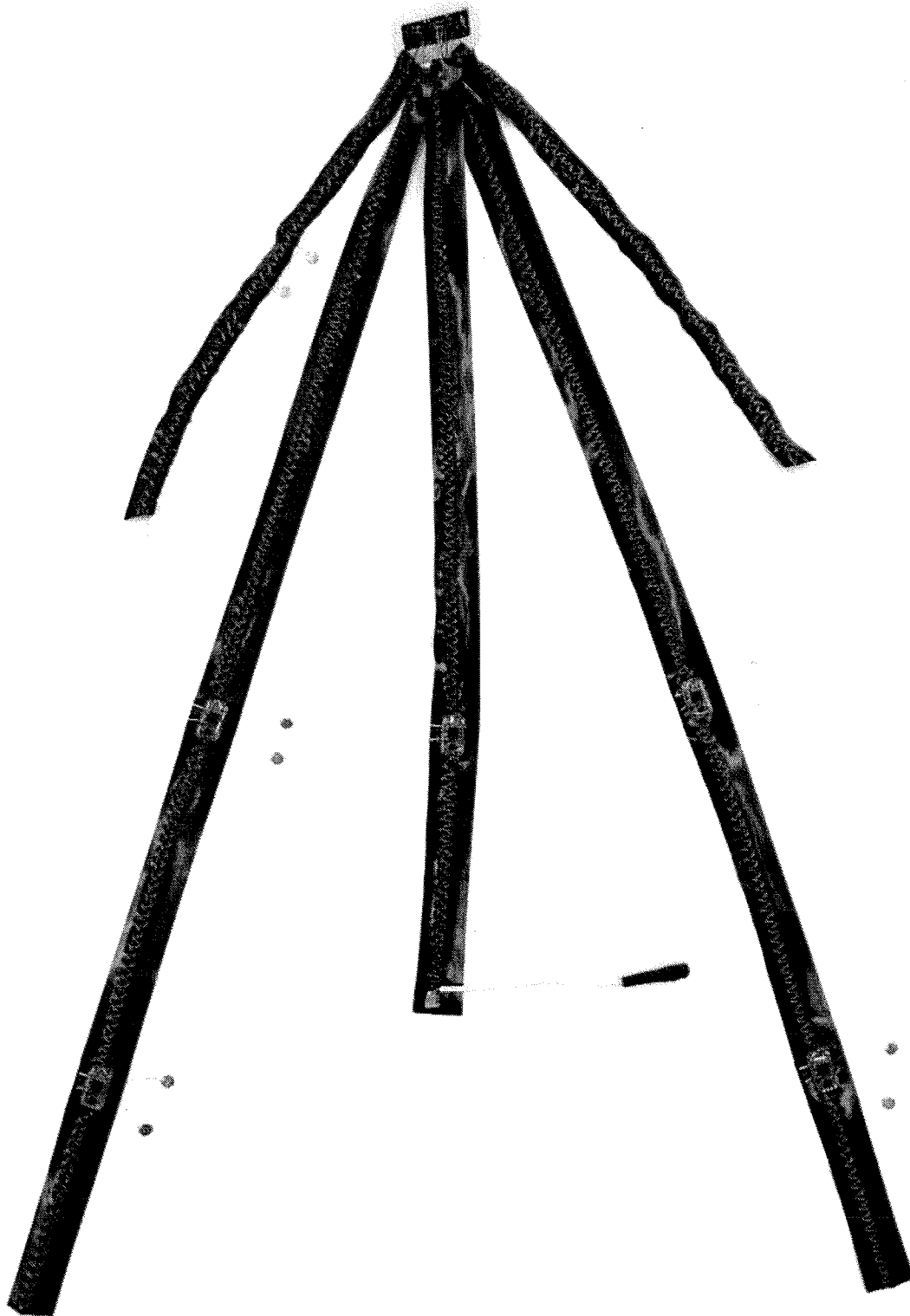

FIG. 35A

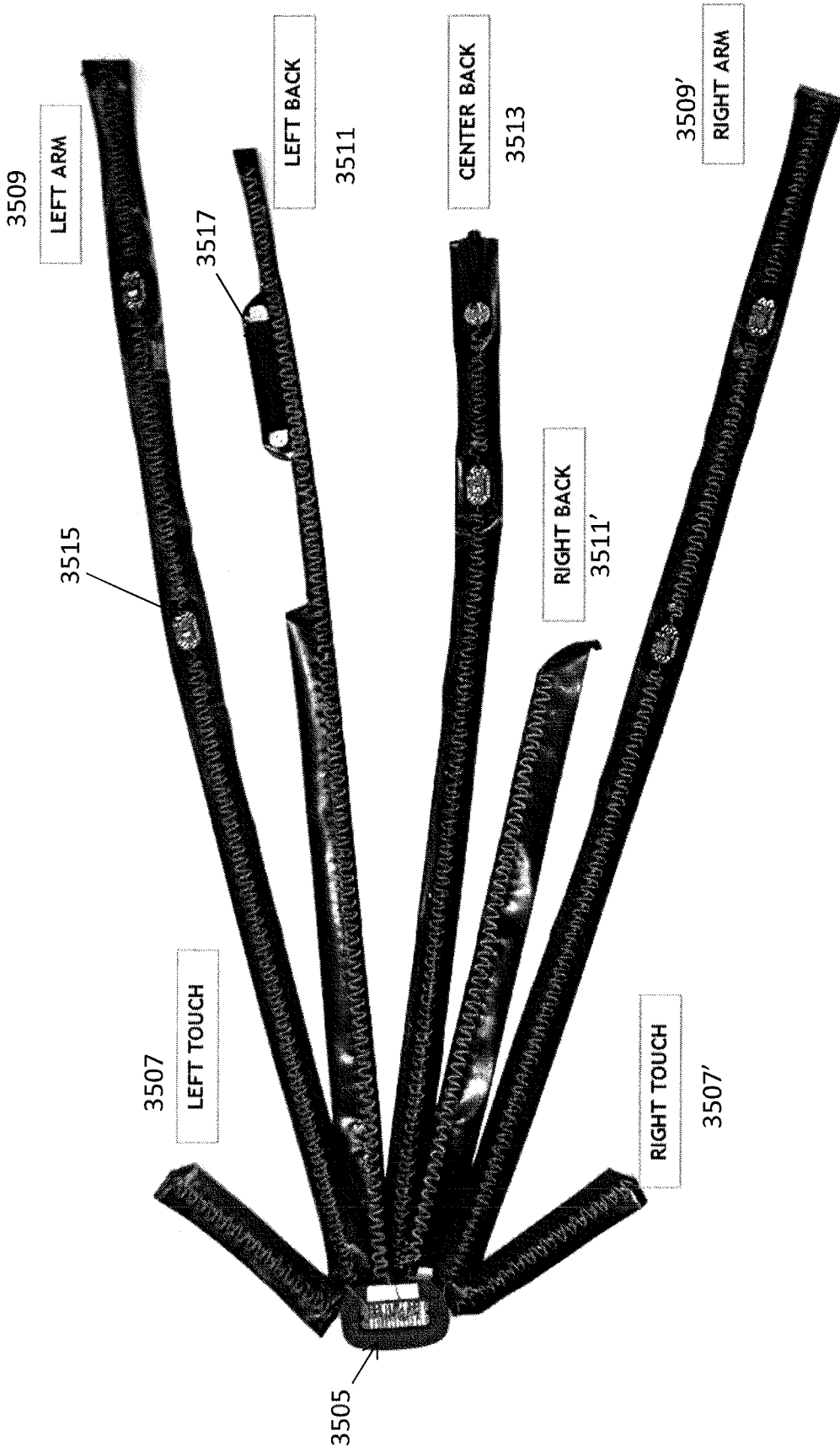

FIG. 35B

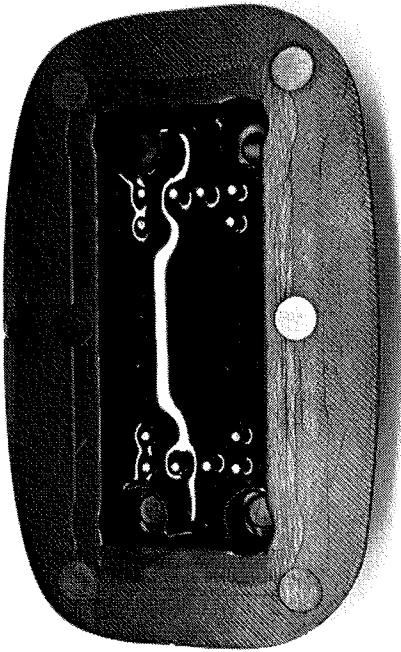

FIG. 37

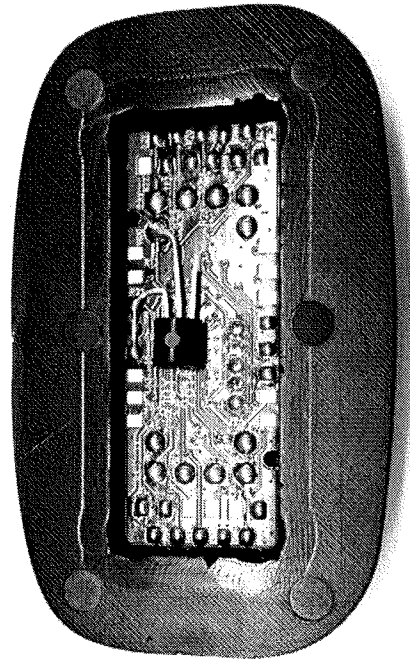

FIG. 39

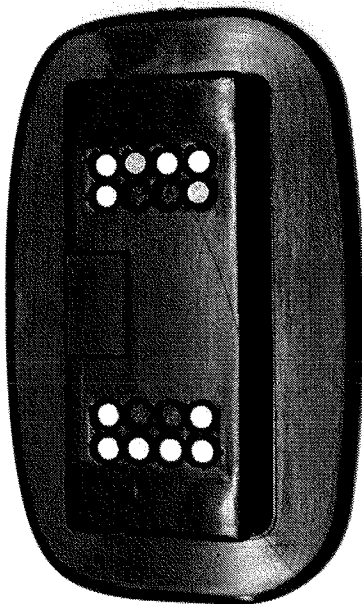

FIG. 36

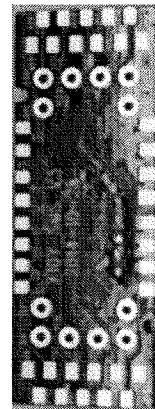

FIG. 38

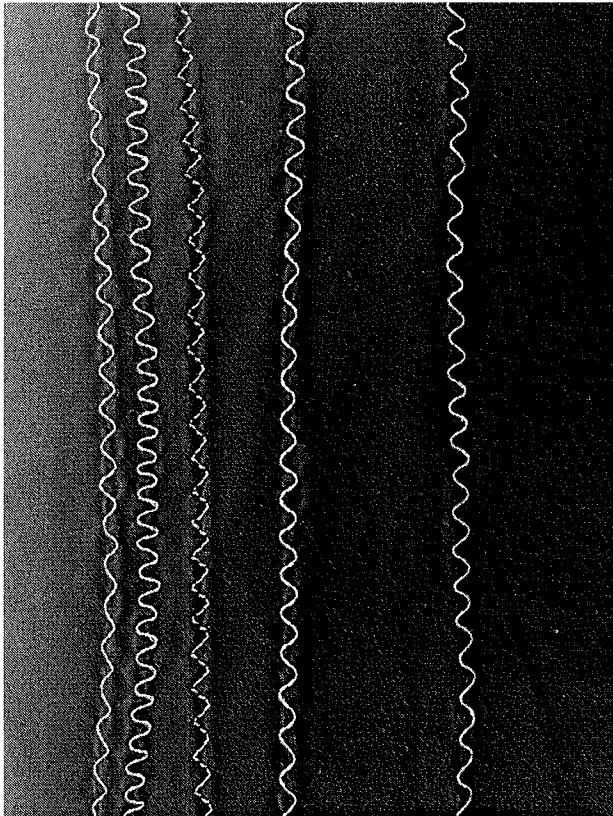

FIG. 40A

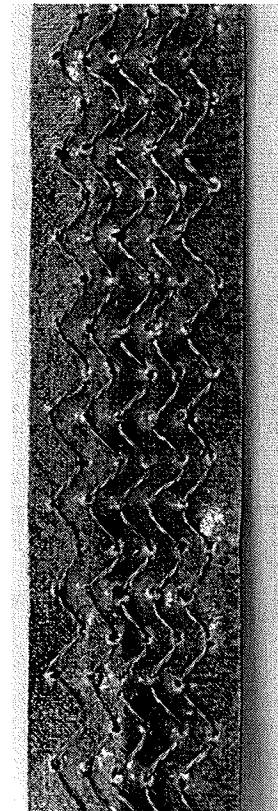

FIG. 40B

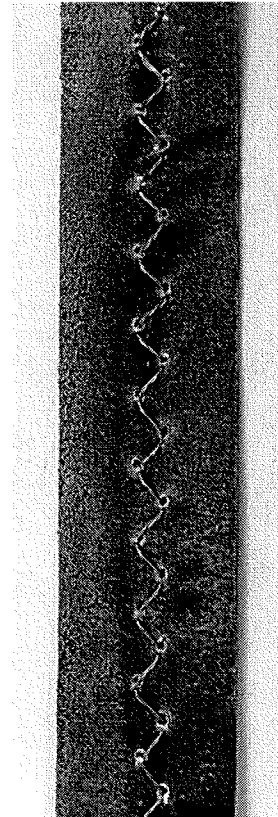

FIG. 40C

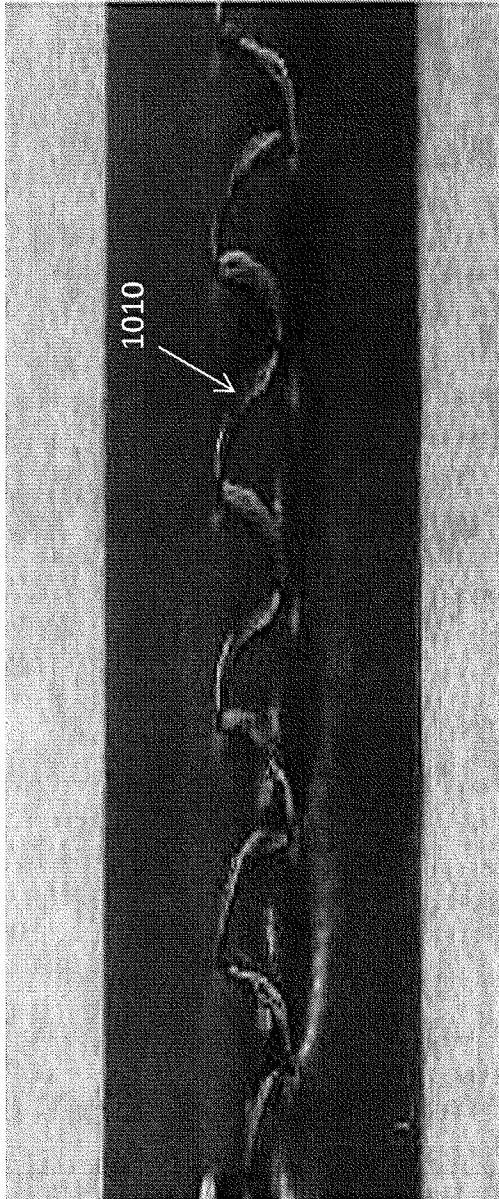

FIG. 41

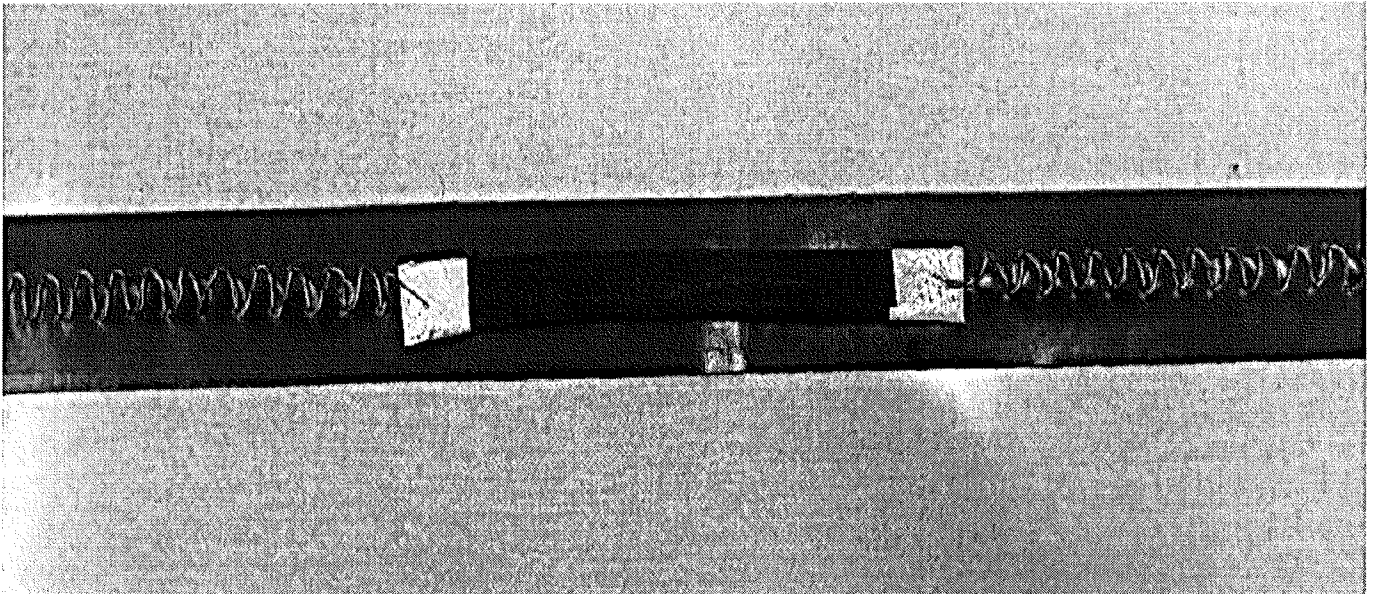

FIG. 42

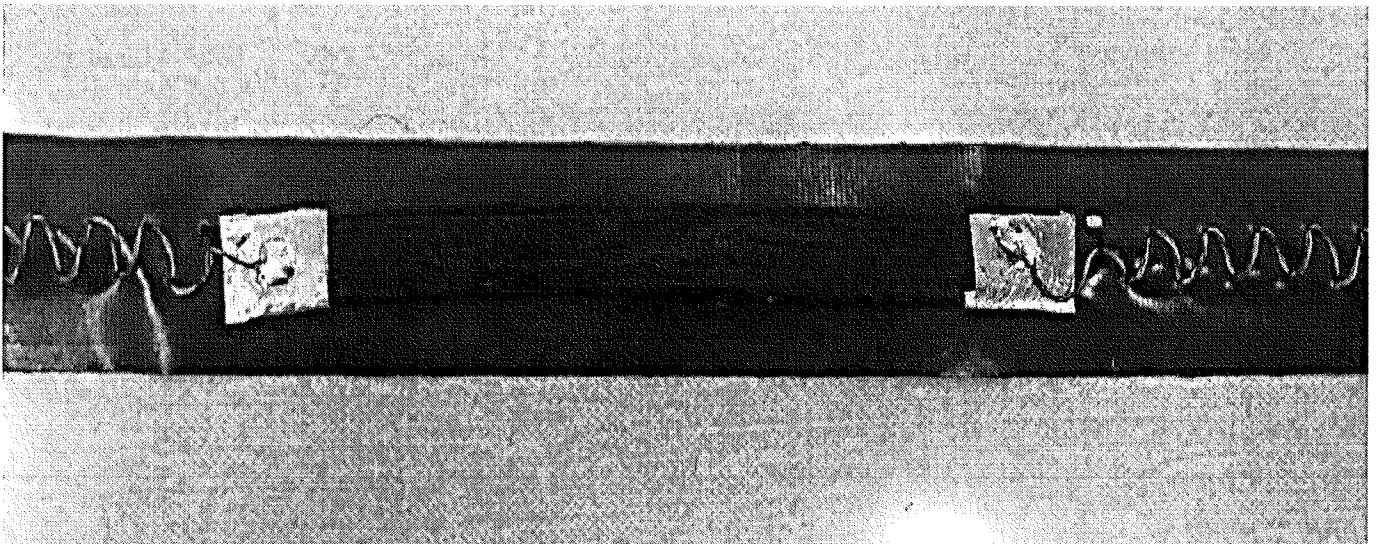

FIG. 43

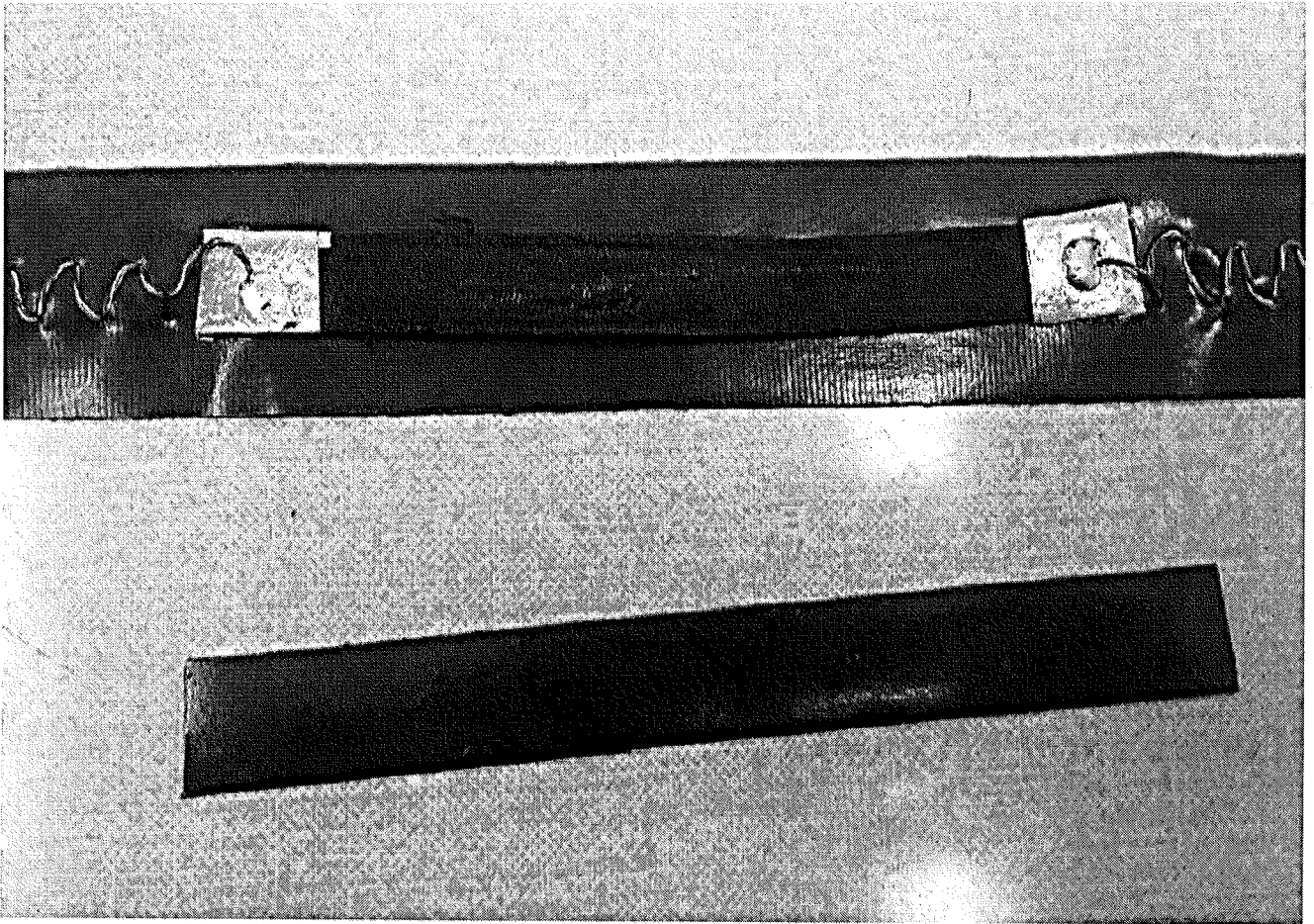

FIG. 44

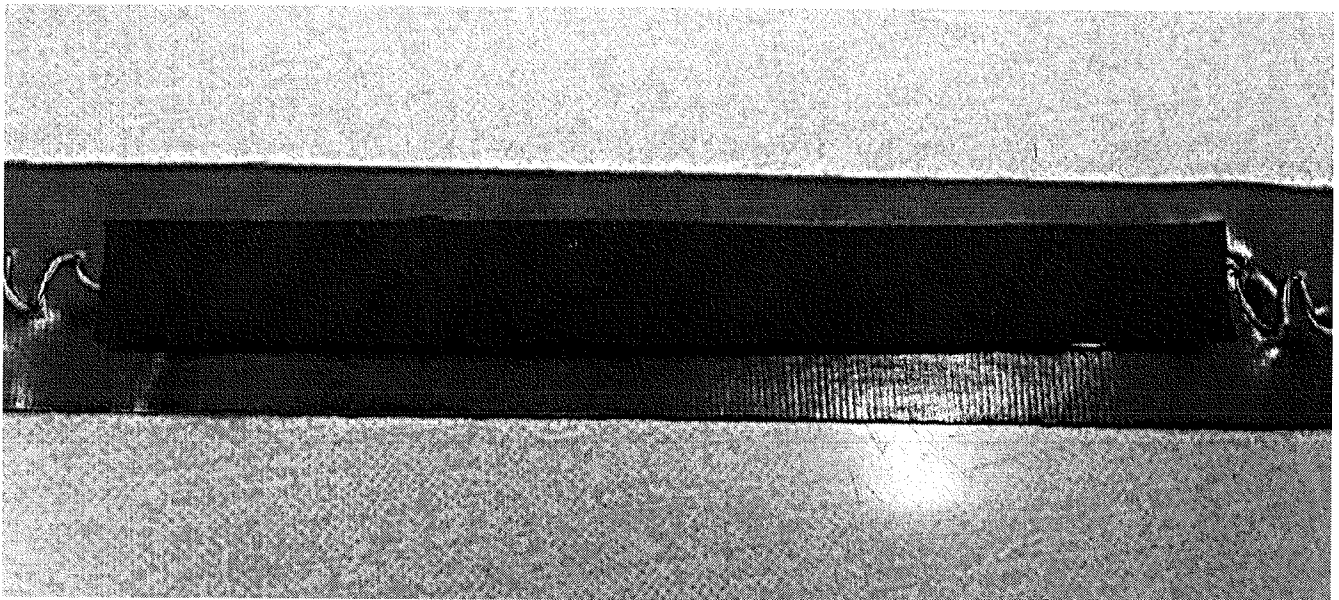

FIG. 45

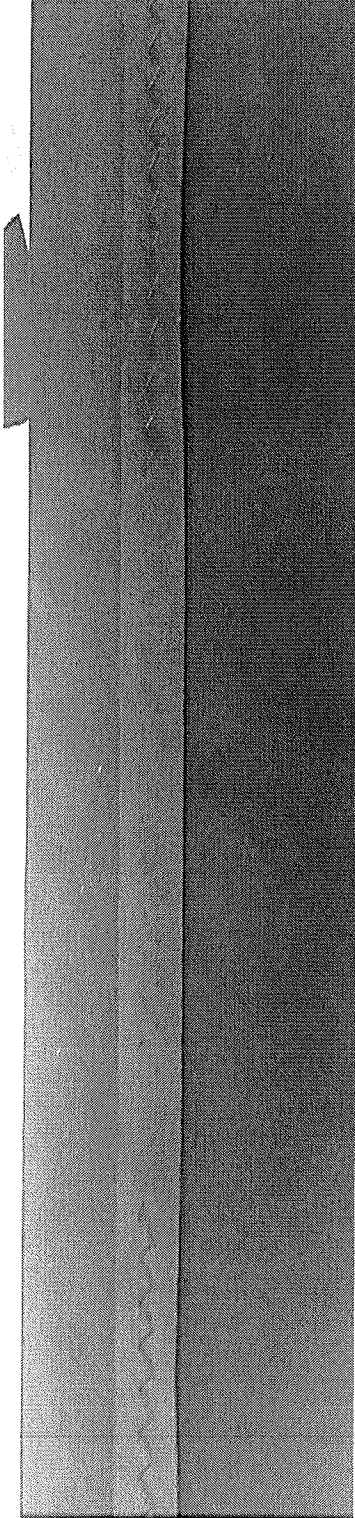

FIG. 46

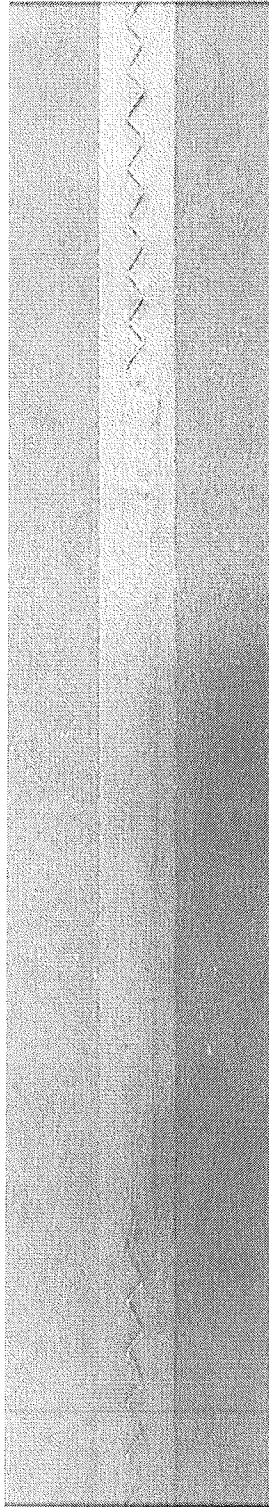

FIG. 47

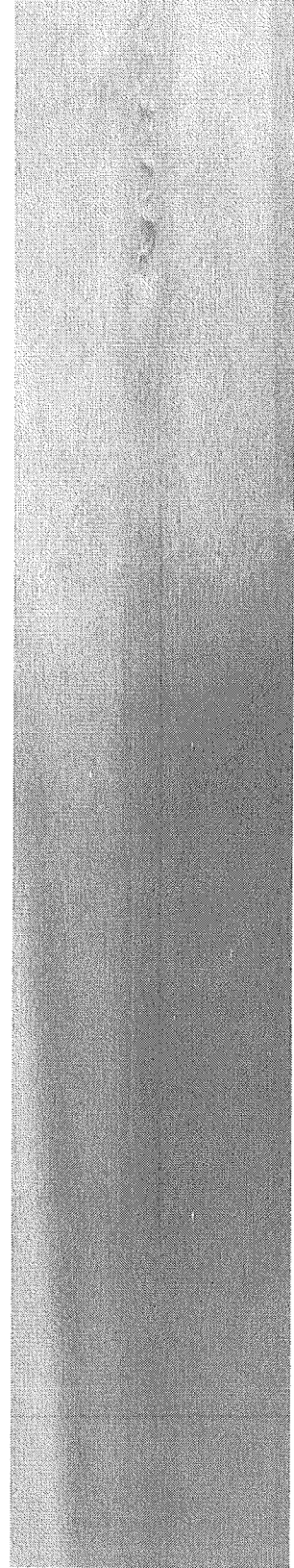

FIG. 48

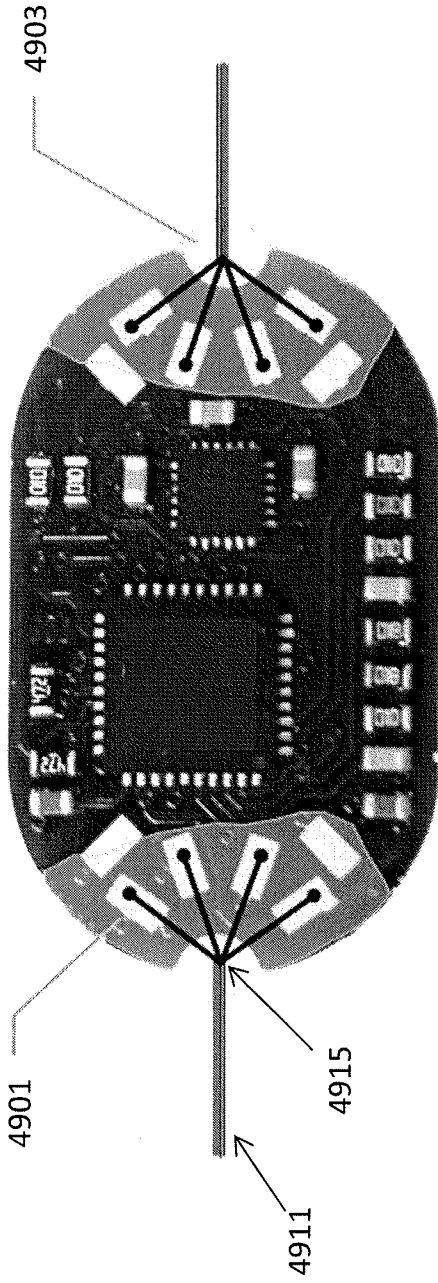

FIG. 49

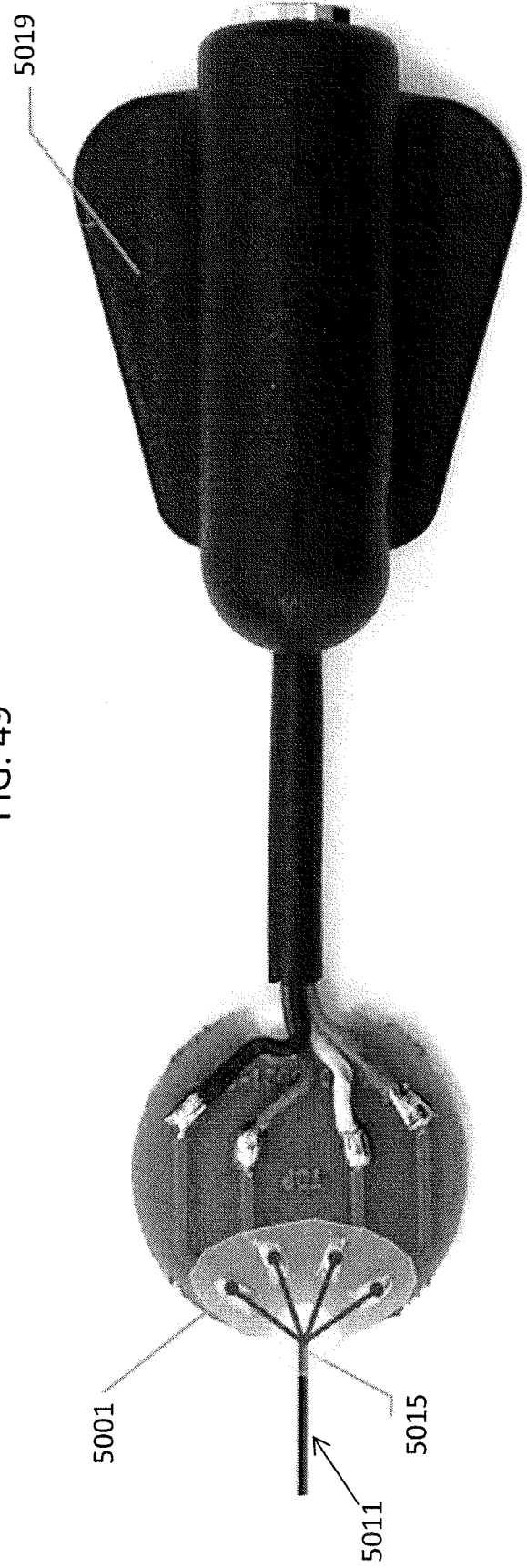

FIG. 50

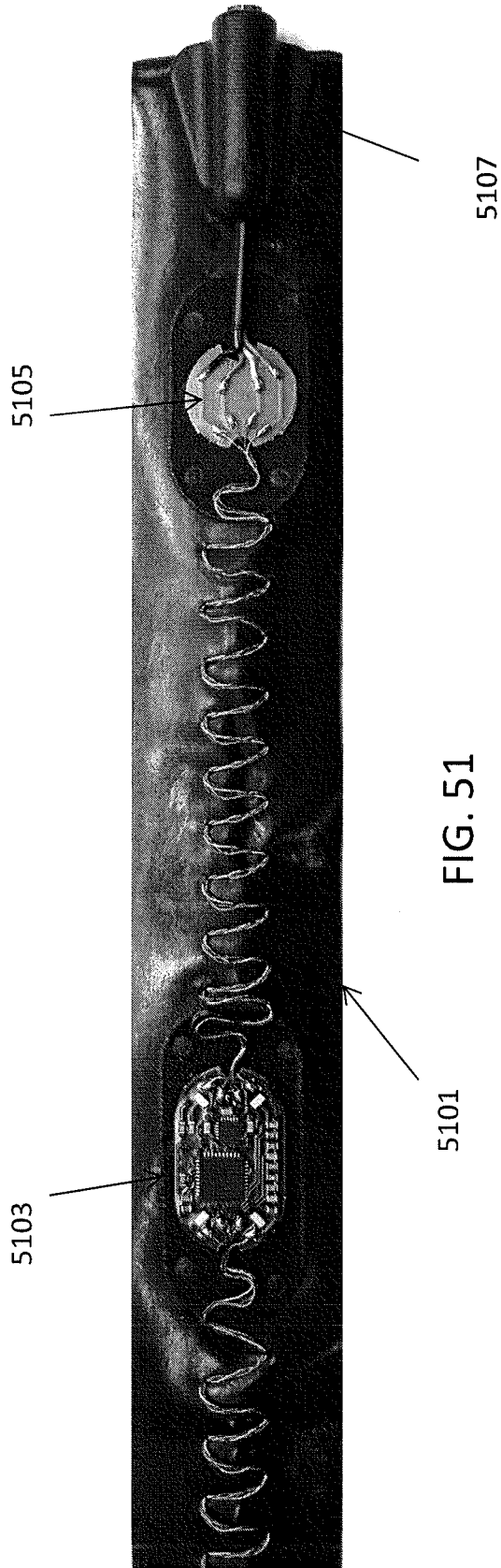

FIG. 51

INTERNATIONAL SEARCH REPORT

International application No
PCT/IB2016/001146

A. CLASSIFICATION OF SUBJECT MATTER

INV. A61B5/00 A61B5/0205 A41D1/00
ADD.

According to International Patent Classification (IPC) or to both national classification and IPC

B. FIELDS SEARCHED

Minimum documentation searched (classification system followed by classification symbols)
A61B A41D

Documentation searched other than minimum documentation to the extent that such documents are included in the fields searched

Electronic data base consulted during the international search (name of data base and, where practicable, search terms used)

EPO-Internal, WPI Data

C. DOCUMENTS CONSIDERED TO BE RELEVANT

Category*	Citation of document, with indication, where appropriate, of the relevant passages	Relevant to claim No.
X	US 2015/040282 A1 (LONGINOTTI-BUITONI GIANLUIGI [US] ET AL) 12 February 2015 (2015-02-12) paragraphs [0085], [0377], [0470] - [0472] -----	1-24
X	EP 2 314 744 A2 (SILVERAY CO LTD [KR]) 27 April 2011 (2011-04-27) paragraphs [0034], [0037], [0088], [0092], [0105], [0162] -----	1-24
A	US 2003/139692 A1 (BARREY ERIC [FR] ET AL) 24 July 2003 (2003-07-24) paragraph [0109] -----	1-24
X	WO 2008/153786 A1 (FOSTER MILLER INC [US]; FARRELL BRIAN [US]; STREETER RICHARD [US]; BOW) 18 December 2008 (2008-12-18) page 16, lines 7-23 -----	1-24

Further documents are listed in the continuation of Box C.

See patent family annex.

* Special categories of cited documents :

- "A" document defining the general state of the art which is not considered to be of particular relevance
- "E" earlier application or patent but published on or after the international filing date
- "L" document which may throw doubts on priority claim(s) or which is cited to establish the publication date of another citation or other special reason (as specified)
- "O" document referring to an oral disclosure, use, exhibition or other means
- "P" document published prior to the international filing date but later than the priority date claimed

"T" later document published after the international filing date or priority date and not in conflict with the application but cited to understand the principle or theory underlying the invention

"X" document of particular relevance; the claimed invention cannot be considered novel or cannot be considered to involve an inventive step when the document is taken alone

"Y" document of particular relevance; the claimed invention cannot be considered to involve an inventive step when the document is combined with one or more other such documents, such combination being obvious to a person skilled in the art

"&" document member of the same patent family

Date of the actual completion of the international search

30 November 2016

Date of mailing of the international search report

08/12/2016

Name and mailing address of the ISA/

European Patent Office, P.B. 5818 Patentlaan 2
NL - 2280 HV Rijswijk
Tel. (+31-70) 340-2040,
Fax: (+31-70) 340-3016

Authorized officer

Pohjamo, Terhi

INTERNATIONAL SEARCH REPORT

Information on patent family members

International application No

PCT/IB2016/001146

Patent document cited in search report	Publication date	Patent family member(s)	Publication date
US 2015040282	A1	12-02-2015	NONE

EP 2314744	A2	27-04-2011	CN 102046864 A 04-05-2011
			CN 102912509 A 06-02-2013
			CN 102912510 A 06-02-2013
			CN 102912511 A 06-02-2013
			CN 102912515 A 06-02-2013
			CN 102912520 A 06-02-2013
			CN 102912521 A 06-02-2013
			EP 2314744 A2 27-04-2011
			JP 5347022 B2 20-11-2013
			JP 5367144 B2 11-12-2013
			JP 5470444 B2 16-04-2014
			JP 5679587 B2 04-03-2015
			JP 5679588 B2 04-03-2015
			JP 2011521122 A 21-07-2011
			JP 2013057161 A 28-03-2013
			JP 2013079483 A 02-05-2013
			JP 2013079484 A 02-05-2013
			JP 2013079485 A 02-05-2013
			US 2011074380 A1 31-03-2011
			WO 2009145536 A2 03-12-2009

US 2003139692	A1	24-07-2003	AT 372089 T 15-09-2007
			AU 3560901 A 14-08-2001
			CA 2399182 A1 09-08-2001
			DE 60130325 T2 29-05-2008
			DK 1261279 T3 02-01-2008
			EP 1261279 A1 04-12-2002
			ES 2292560 T3 16-03-2008
			FR 2804596 A1 10-08-2001
			PT 1261279 E 06-12-2007
			US 2003139692 A1 24-07-2003
			WO 0156470 A1 09-08-2001

WO 2008153786	A1	18-12-2008	CA 2689267 A1 18-12-2008
			EP 2150171 A1 10-02-2010
			US 2007299325 A1 27-12-2007
			WO 2008153786 A1 18-12-2008
