

Oct. 15, 1935.

R. C. LANG

2,017,100

NEEDLE OR TUFTING DEVICE

Filed June 6, 1931

3 Sheets-Sheet 1

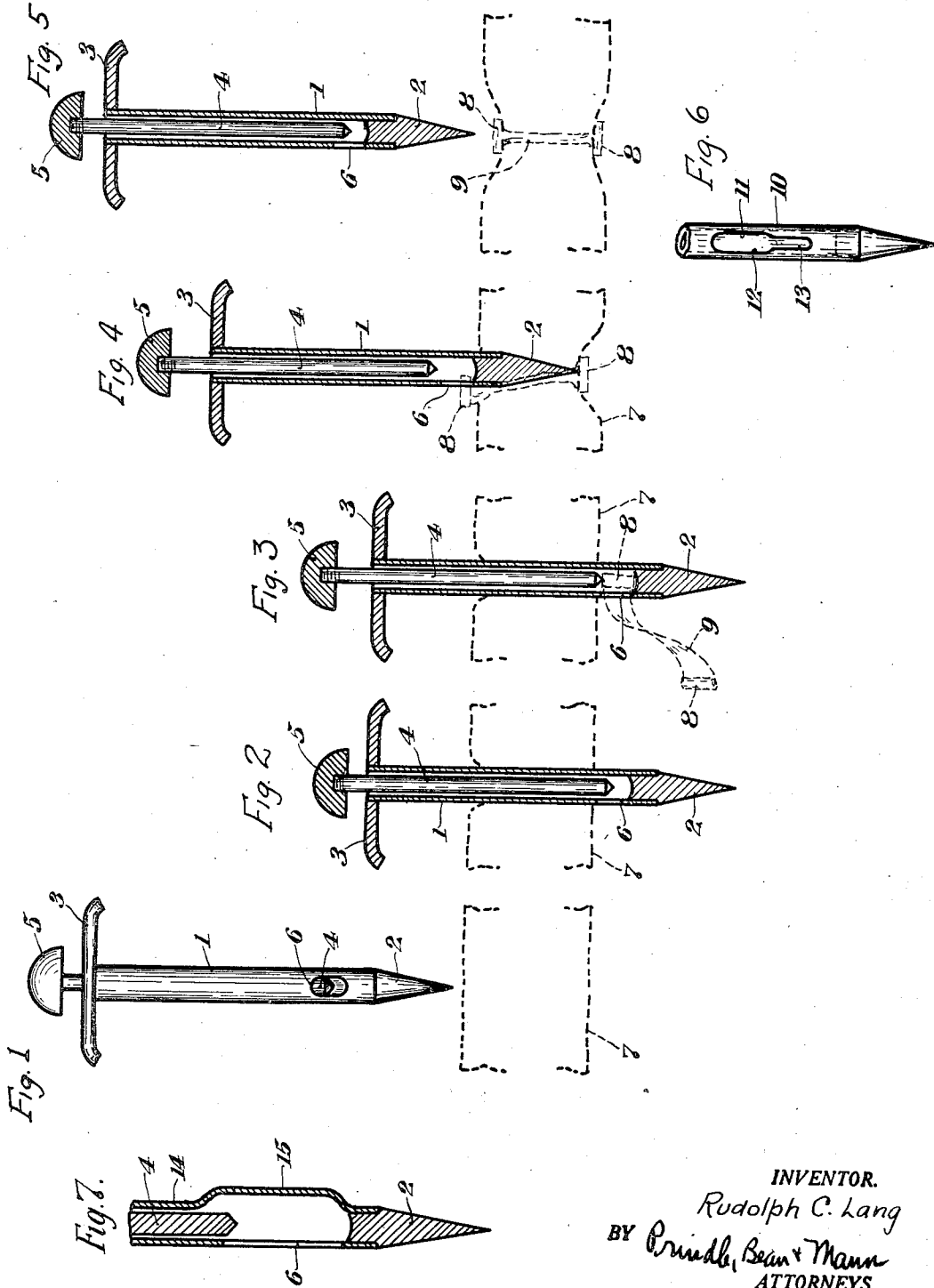

INVENTOR.  
Rudolph C. Lang  
BY *Ernie, Bean & Mann*  
ATTORNEYS.

Oct. 15, 1935.

R. C. LANG

2,017,100

NEEDLE OR TUFTING DEVICE

Filed June 6, 1931

3 Sheets-Sheet 2

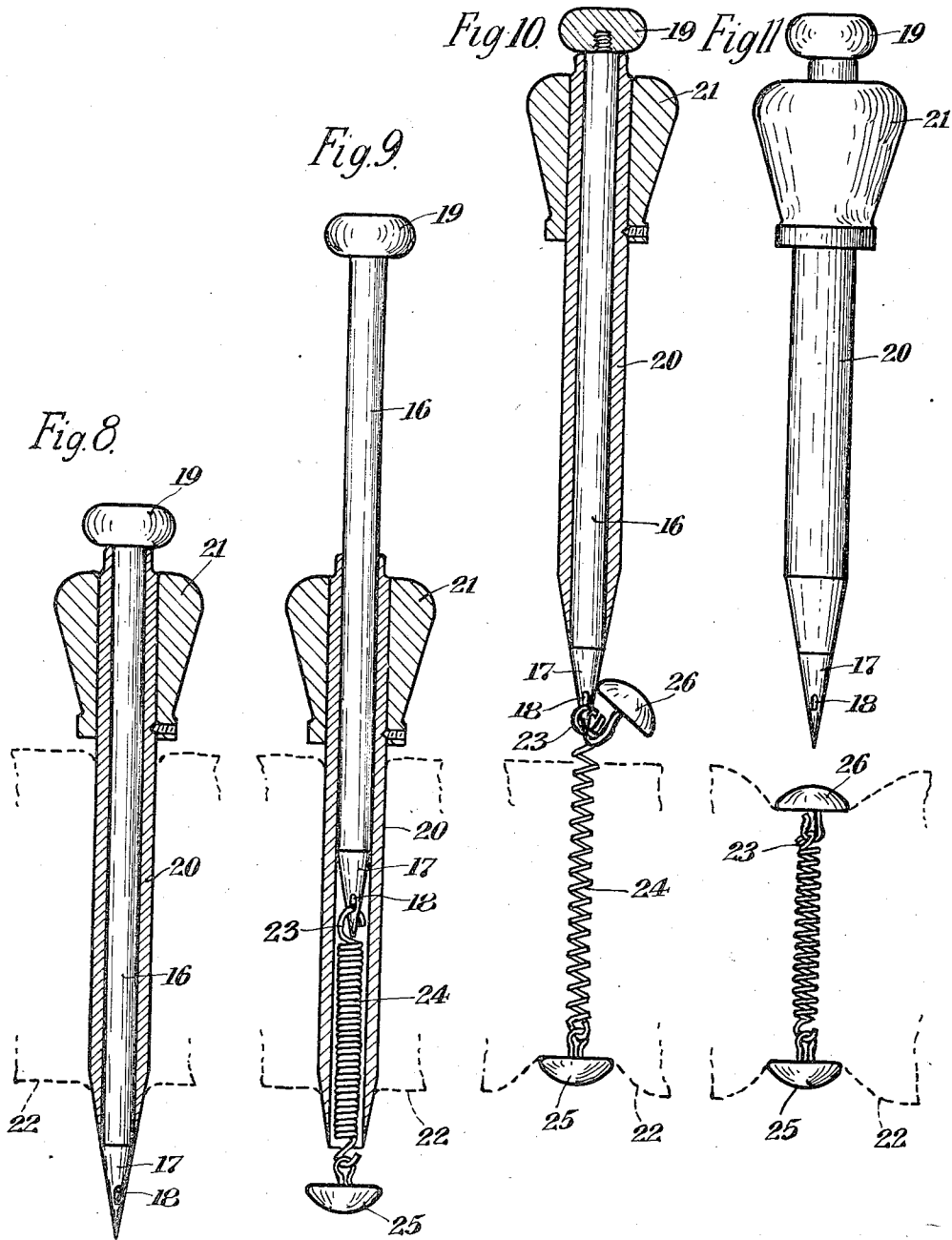

Rudolph C. Lang  
INVENTOR.

BY *Prindle, Bean & Mann*  
ATTORNEYS.

Oct. 15, 1935.

R. C. LANG

2,017,100

NEEDLE OR TUFTING DEVICE

Filed June 6, 1931

3 Sheets-Sheet 3

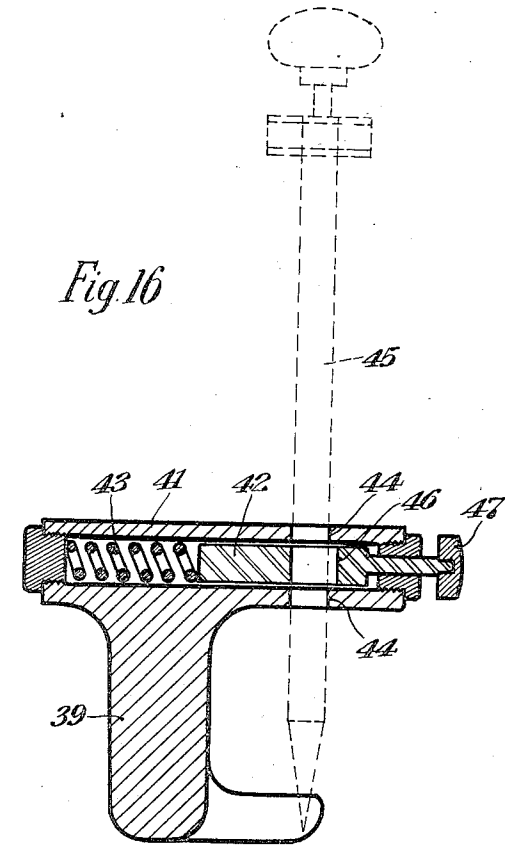

Fig. 16

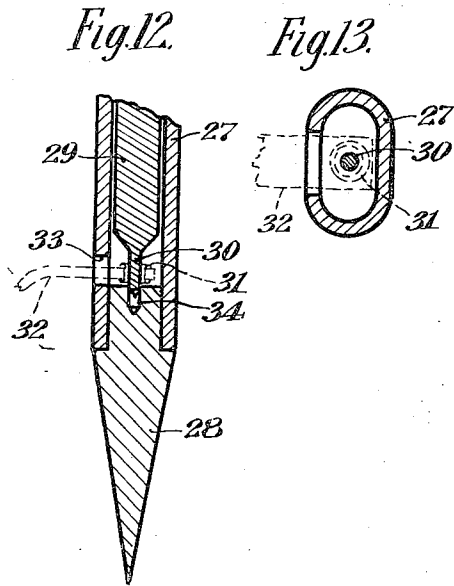

Fig. 12

Fig. 13

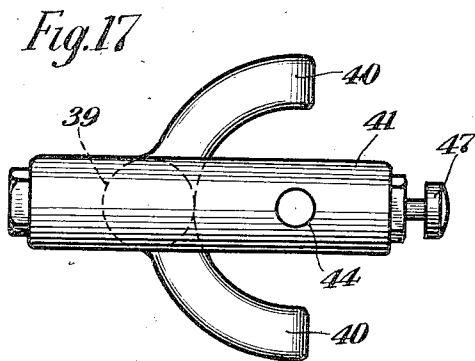

Fig. 17

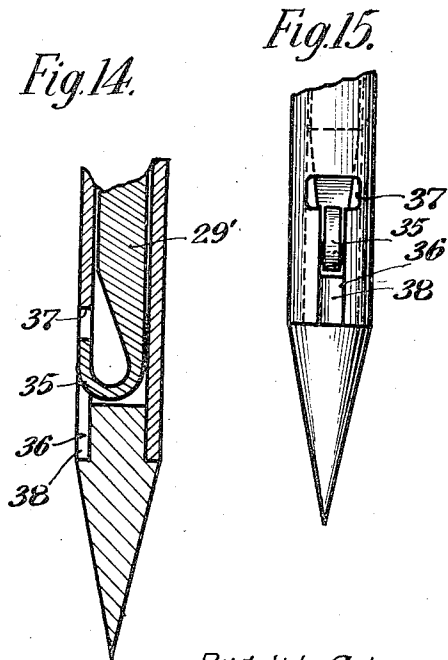

Fig. 14

Fig. 15

Rudolph C. Lang.  
INVENTOR.

BY *Prindle, Bean & Mann*  
ATTORNEYS.

# UNITED STATES PATENT OFFICE

2,017,100

## NEEDLE OR TUFTING DEVICE

Rudolph C. Lang, New York, N. Y., assignor to  
to A. B. A. Specialties Company, Inc., New York,  
N. Y., a corporation of New York

Application June 6, 1931, Serial No. 542,541

3 Claims. (Cl. 223—102)

This invention relates to improvements in tufting devices and is of the general type of devices which are termed "needles". This particular device is primarily adapted for the practice of the method and the use of the tufting elements disclosed in a copending application for patent filed by Miss Annette Fridolph Serial Number 542,799, filed June 8, 1931.

An important characteristic of said method and said tufting elements is the use of a complete preformed tufting element which is placed in its final tufting position by one operation on the part of the tufting operator. The tufting element is provided with means which the needle receives, whereby the tufting element as a whole is drawn through the body being tufted and is then released to complete the tufting operation.

To the accomplishment of the foregoing and such other objects as may hereinafter appear, this invention consists in the construction, combination and arrangement of parts hereinafter described and then sought to be defined in the appended claims, reference being had to the accompanying drawings forming a part hereof and which show, merely for the purpose of illustrative disclosure, several embodiments of my invention, it being expressly understood, however, that various changes may be made in practice within the scope of the claims without digressing from my inventive idea.

In the drawings—

Figure 1 represents a side elevation of one form of device of needle constructed to embody my invention in position to be inserted or passed through a mattress or other body to be tufted.

Figure 2 is a vertical cross section showing the device of Figure 1 after it has been inserted and passed through the body.

Figure 3 is a view similar to Figure 2 showing the tufting element in position in dotted lines.

Figure 4 is a vertical sectional view showing the needle or device drawn or pulled back through the body with the tufting element released, but before it assumes its final position.

Figure 5 is a similar view with the needle or device completely withdrawn and the tufting element in its final position.

Figure 6 is a front elevational view of a portion of the needle showing a modified detail of construction.

Figure 7 is a similar view showing a slight modification.

Figure 8 is a vertical cross section of a modified form of tufting device or needle inserted through the body to be tufted.

Figure 9 is a similar view with the movable part of the tufting device or needle at an intermediate stage of its movement.

Figure 10 is a similar view showing the tufting device or needle just after it has been pulled back through the body being tufted and before the tufting element is released.

Figure 11 is a side elevation showing the tufting element released and the ornamental button attached, all parts assuming their final position.

Figure 12 is a vertical cross section of the lower end portion of another modified construction of tufting device or needle.

Figure 13 is a horizontal transverse cross section taken through the opening in the lower end of the needle shown in Figure 12.

Figures 14 and 15 are a vertical cross section and a front elevation respectively, of another modified form.

Figure 16 is a vertical cross section of a vise or holding element for the needle, the needle being shown in dotted lines.

Figure 17 is a top plan view of the vise shown in Figure 16.

Referring now to the drawings, the numeral 1 designates the body of the tufting device or needle which is preferably tubular in construction and provided with the solid tapered sharpened end or point member 2. At its upper end the body 1 is provided with the laterally extending flange members 3 constituting holding means. An elongated plunger 4 is slidably positioned within the tubular body 1 and may be provided with the head 5. The tubular body 1 is provided with a suitable opening or slot 6 near the point member 2.

The operation of this form of device is clearly illustrated in Figures 1 to 5 inclusive. The point is passed entirely through the body 7 which is to be tufted, into the position shown in Figure 2. The plunger 4 is lifted to permit the insertion of the stiffened tufting head 8 on one end of the tufting element 9. This is held in position due to its engagement by the end of the plunger 4 and slight pressure by the finger or fingers of the operator upon the head 5 of said plunger. The tufting element 9 is, of course, of sufficient length to pass entirely through the body 7 and extend from the bottom to the top surface thereof. The tufting device or needle is then withdrawn to the position shown in Figure 4 where the stiffened tufting head 8 has been pulled entirely through the body 7. It is released by the removal of the pressure against the head 5 of the plunger 4 and due to the pull of the tufting element 9, it be-

ing understood, of course, that the other tufting head 8 has engaged the lower surface of the body as clearly shown in Figure 4, so that the upward movement of the tufting element and the upper tufting head 8 is limited. Further withdrawal of the tufting device or needle as illustrated in Figure 5, permits the tufting element to assume the normal position as shown in Figure 5.

In some instances, it is not necessary to use the plunger 4, in which event the body 10 of the tufting device or needle is provided with a slot or recess 11 of the bayonet slot type, having the larger inserting opening 12 and the narrower holding opening or slot 13. In this form the tufting head is merely inserted into the slot when the needle is in the position shown in Figure 3 and is held locked therein during the withdrawal or backward movement of the tufting device or needle. When this movement is complete, the stiffened head 8 is released by the fingers of the operator or in any other suitable manner.

In some cases it is desirable to use a tufting head 8 which is of substantial width or thickness and in that event, it may be necessary to slightly bow or enlarge the tubular body 14 of the tufting device or needle as indicated at 15 in Figure 7. This provides sufficient room for the use of a stiffened tufting head of considerable greater width and thickness. Such type may be referred to as the flat type, and such construction may be used with my tufting device or needle with equal facility to the other types.

In the form of device shown in Figures 8 to 11 inclusive, I provide a needle proper 16 having a sharp point end 17 provided with an eye or opening 18 and having an operating head or knob 19 at the other end. This needle proper 16 is slidably mounted in the tubular case or body 20 which is provided with the head member 21 at its upper end. The head 19 of the needle engages the end of the tubular body 20 to limit its downward movement. In the use of this form of device it is inserted as a whole through the body 22 to be tufted to the position shown in Figure 8. There the hook member 23 of a suitable tufting element 24, preferably having a button 25 at the other end, is passed through the eye or opening 18, see Figure 9. Then the needle proper 16 is drawn upwardly until the upper hook 23 extends beyond the upper surface of the body being tufted when the tubular body 20 is drawn or pulled upwardly to expose the upper hook member 23 so as to permit the attachment of the upper button 25 thereto, see Figure 10. Then the hook member 23 is released from the needle and the tufting element assumes the position shown in Figure 11 of the drawings.

In the form of construction shown in Figures 12 to 15 inclusive, the tufting device or needle includes the tubular body or case 27 having the sharpened point or end 28 and also having a plunger 29 slidably mounted therein. In the form shown in Figures 12 and 13 the plunger 29 has the reduced end 30 adapted to pass through the eyelet 31 provided in the end of the tufting element 32, an opening 33 being provided in the tubular body 29 to permit the insertion of the end of the tufting element therein. If necessary, the point member 28 is provided with a recess 34 to receive and hold the reduced end 30 of the plunger 29 when in its lowered position.

In the form shown in Figures 14 and 15, the plunger 29 is provided with the hooked end 35

which is exposed through a slot 36 having a wide top opening portion 37 and the elongated narrower portion 38. This hook construction is adapted to be used in connection with an eyelet or a hooked end construction of the tufting device as disclosed in said Fridolph application Serial No. 542,799.

It may be desirable to use a holding element or vise in connection with said tufting devices or needles, and one form of such device is shown in Figures 16 and 17. It comprises a base or support 39 formed with spreading feet 40 and having a horizontally extending barrel portion 41 in which is slidably mounted a plunger 42 normally held in a forward position by means of coil spring, 43. Alined openings 44 are provided in said barrel 41 to permit the passage of the tufting device or needle 45 therethrough. The plunger is likewise formed with an opening 46 which is in alignment with said openings 44 and the end of the plunger is extended beyond the barrel and provided with the operating head or button 47. When the operator presses against the button with sufficient force, the opening 46 which should be preferably wider than the openings 44, will permit the free passage of the needle therethrough, but when the operator releases his pressure against the head or button 47, spring 43 forces the plunger against the needle 45 and holds it securely in position in said vise or holding means so that the operator has one hand free to manipulate the end of the tufting element so as to release that end or apply a button thereto or for some other purpose.

What I claim is:

1. A hand needle for tufting mattresses, upholstery and the like, including an elongated tubular body having a handle at one end and provided with a point at the other end, said body having an opening leading thereinto near its pointed end, an elongated plunger having a handle at one end movably mounted within said hollow body and having a hook at its lower end which in one position is located near the opening into said hollow body so as to receive an end member of a tufting element and to hold the same in said hollow body while the latter is in position within the article being tufted, said hollow body being then adapted to be withdrawn through the article being tufted.

2. A hand needle for tufting mattresses, upholstery and the like, including an elongated hollow body having a sharp pointed end, said hollow body having an opening formed into the lower portion thereof with a restricted slot communicating with said opening, the opening being adapted to receive the end member of a complete tufting element and to permit the passage of the material forming the body of the tufting element into the restricted slot so that the end member of the tufting element will be held within the needle during its passage through the article being tufted to draw the tufting element through said article being tufted.

3. A device of the character described, including a tubular body and an elongated plunger slidably mounted therein and adapted to engage and hold part of a tufting element and to pull the latter entirely through a body being tufted, said tubular body having an opening to receive said part of said tufting element, said body being formed with an offset portion at said opening so as to receive an element of greater width than the normal diameter of said tubular body.