



- (51) International Patent Classification:
B23B 51/00 (2006.01) B23B 51/02 (2006.01)
- (21) International Application Number:
PCT/US2012/036730
- (22) International Filing Date:
7 May 2012 (07.05.2012)
- (25) Filing Language: English
- (26) Publication Language: English
- (30) Priority Data:
20 2011 100 380.2 6 May 2011 (06.05.2011) DE
- (71) Applicant (for all designated States except US):
ILLINOIS TOOL WORKS INC. [US/US]; 3600 West Lake Avenue, Glenview, Illinois 60026 (US).
- (72) Inventors; and
- (75) Inventors/Applicants (for US only): LAMPE, Rainer [DE/DE]; Dechant-Ribbers-Straße 17, 22117 Hamburg (DE). KERSTEN, Heinrich [DE/DE]; Auf dem Esch 5, 27283 Verden (DE).
- (74) Agent: HAUPTMAN, Benjamin J.; 1700 Diagonal Road, Suite 300, Alexandria, Virginia 22314 (US).

- (81) Designated States (unless otherwise indicated, for every kind of national protection available): AE, AG, AL, AM, AO, AT, AU, AZ, BA, BB, BG, BH, BR, BW, BY, BZ, CA, CH, CL, CN, CO, CR, CU, CZ, DE, DK, DM, DO, DZ, EC, EE, EG, ES, FI, GB, GD, GE, GH, GM, GT, HN, HR, HU, ID, IL, IN, IS, JP, KE, KG, KM, KN, KP, KR, KZ, LA, LC, LK, LR, LS, LT, LU, LY, MA, MD, ME, MG, MK, MN, MW, MX, MY, MZ, NA, NG, NI, NO, NZ, OM, PE, PG, PH, PL, PT, QA, RO, RS, RU, RW, SC, SD, SE, SG, SK, SL, SM, ST, SV, SY, TH, TJ, TM, TN, TR, TT, TZ, UA, UG, US, UZ, VC, VN, ZA, ZM, ZW.
- (84) Designated States (unless otherwise indicated, for every kind of regional protection available): ARIPO (BW, GH, GM, KE, LR, LS, MW, MZ, NA, RW, SD, SL, SZ, TZ, UG, ZM, ZW), Eurasian (AM, AZ, BY, KG, KZ, RU, TJ, TM), European (AL, AT, BE, BG, CH, CY, CZ, DE, DK, EE, ES, FI, FR, GB, GR, HR, HU, IE, IS, IT, LT, LU, LV, MC, MK, MT, NL, NO, PL, PT, RO, RS, SE, SI, SK, SM, TR), OAPI (BF, BJ, CF, CG, CI, CM, GA, GN, GQ, GW, ML, MR, NE, SN, TD, TG).

Published: — with international search report (Art. 21(3))

(54) Title: MASONRY DRILL BIT

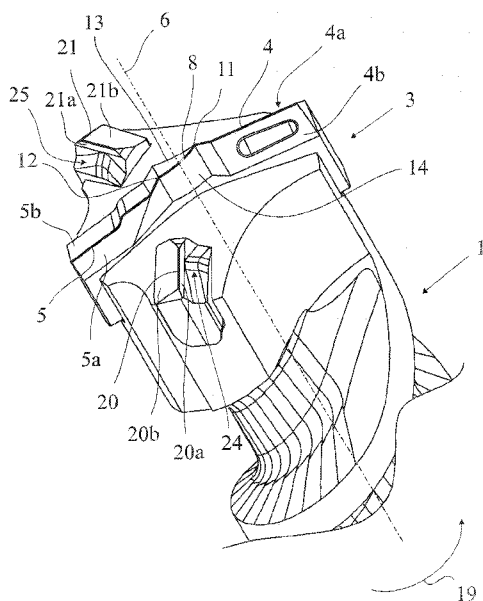

Fig. 2

(57) Abstract: The invention is directed to a masonry drill bit having a shank (1) having an insertion end (2) and a drill head (3), wherein the main cutting edges (4, 5) each converge toward a transverse cutting edge (8) arranged in the central region of the drill head (3), wherein the transverse cutting edge (8) is formed in a substantially concave manner with two transverse cutting tips (11, 12) at its ends. It is essential that the transverse cutting edge (8) is formed by two adjacent channels (13, 14) and in that each transverse cutting tip (11, 12) is adjoined by two webs (15-18) which provide the lateral boundaries of the channels (13, 14) by forming additional edges, such that each channel (13, 14) has a leading web (16, 17) and a trailing web (15, 18).



- 1 -

Masonry drill bit

The invention relates to a masonry drill bit as per the preamble of claim 1, to a masonry drill bit as per the preamble of claim 22 and to a cutting insert as per the preamble of claim 29.

The masonry drill bit in question is suitable for drilling into concrete or reinforced concrete, but also into other masonry, rock or the like. The masonry drill bit in question is usually equipped with an insertion portion, a helix adjoining the insertion portion and a head portion adjoining the helix.

Essential criteria for the design of masonry drill bits of the kind in question are easy centering, the achievable drilling progress per time unit, the high period of use and not least the low degree of wear.

The known masonry drill bit (DE 199 44 406 C2), on which the present invention is based, is equipped with a cutting insert having a substantially roof-shaped configuration. On both sides of the longitudinal axis of the drill bit there extend two main cutting edges which are each formed by a leading rake face and by a trailing flank adjoining the rake face. The main cutting edges merge into a transverse cutting edge in the central region of the drill head. What is interesting in this case is the fact that the transverse cutting edge is formed in a concave manner as seen from the side. This type of chisel edge is also known as a "point-thinned chisel edge".

Surprisingly, the centering action of the above known masonry drill bit having a point-thinned chisel edge is extraordinarily good. On account of the fact that there is virtually no obstructing lip in the center of the drill bit, the known masonry drill bit also has

- 2 -

advantages with regard to the achievable drilling progress per time unit. The fact that the transverse cutting edge has, on account of its concave form, two axially protruding transverse cutting tips which lead to a corresponding concentration of force during drilling operation, also plays a particularly important role for the achievable drilling progress.

The invention is based on the problem of configuring and developing the known masonry drill bit such that the achievable drilling progress is further improved, in particular when reinforced material is drilled.

In the case of a masonry drill bit as per the preamble of claim 1, the above problem is solved by the features in the characterizing part of claim 1.

What is essential is the knowledge that the applicability of the principle of "point-thinned chisel edges" does not have to be limited to the main cutting edges. Rather, this principle can also be applied to regions of the masonry drill bit which are located to the side of the transverse cutting edge and/or of the main cutting edges.

Specifically, it is proposed that the transverse cutting edge is formed by two adjacent channels and that each transverse cutting tip is adjoined by two webs which provide the lateral boundaries of the channels by forming additional edges. Thus, each channel has two lateral webs, specifically a leading web and a trailing web, in each case with regard to the direction of rotation of the masonry drill bit.

The expression "additional edges" should be understood here as meaning that the webs are not a constituent part of the main cutting edge or of the transverse

- 3 -

cutting edge, but rather are expressly formed in addition to the above edges.

According to the proposal, it is provided that the
5 transverse cutting tips effectively continue in the
abovementioned webs, while the transverse cutting edge
continues in the two channels. A longitudinal section
in the region of the two channels thus always results
substantially in the form of a point-thinned chisel
10 edge. As a result, the above-discussed concentration of
force on account of the point-thinned chisel edge can
be extended to the regions to the sides of the chisel
edge. The principle of the point-thinned chisel edge
has effectively been extended to an additional
15 dimension.

In the particularly preferred refinement according to
claim 11, it is provided that at least in each case the
leading web of a channel is formed as a secondary
20 cutting edge. Here, it has been recognized that the
additional webs can also be used as cutting edges.

In the particularly preferred refinements according to
claims 13 and 14, it is provided that the trailing web
25 has less of a cutting action than the leading web,
since the trailing web is set back with regard to
possible cutting engagement. The idea here is to
improve the centering action of the masonry drill bit
by way of the above setting back of the trailing web.
30 Thus, a reduction in the cutting action of the trailing
web is effectively accepted.

In the further preferred refinements according to
claims 15 to 21, it is provided that there are provided
35 at least two auxiliary cutting edges, which each extend
along an auxiliary cutting axis and which are each
arranged at an angle to a main cutting axis.

- 4 -

A masonry drill bit having at least two auxiliary cutting edges of this kind is the subject matter of a further teaching according to claim 22, to which independent importance is attached.

5

This further teaching relates to a masonry drill bit having a shank having an insertion end and a drill head, wherein the drill head has two main cutting edges which extend on both sides of the longitudinal axis of the drill bit, preferably substantially along a main cutting axis, wherein there are provided at least two auxiliary cutting edges which each extend along an auxiliary cutting axis and which are arranged at an angle to a main cutting axis.

15

What is essential is that the auxiliary cutting edge is formed by a leading rake face and by a trailing flank adjoining the rake face, and that a leading ramp with respect to the rake face is provided, said ramp rising axially toward the rake face with regard to the longitudinal axis of the drill bit. The interpretation of the expression "rising axially" proceeds quite generally from the fact that the insertion end is located at the lowest point and the drill head at the highest point.

25

With the above, leading ramp, catching of the auxiliary cutting edge with material to be drilled, in particular with reinforcement present in the material to be drilled, can be reliably ruled out. During drilling, the material to be drilled slides along the ramp, such that the material to be drilled is effectively guided over the cutting edge. Strictly speaking, it is of course the other way round here, with the masonry drill bit sliding on the material to be drilled.

30

35

In the particularly preferred refinement according to claim 25, it is provided that the point at which the

- 5 -

ramp ends in the region of the rake face, preferably in the rake face, of the auxiliary cutting edge is set back axially from the auxiliary cutting edge. With this axial setting back, the desired cutting engagement
5 between the auxiliary cutting edge and the material to be drilled can be set precisely. In this way, an optimal compromise between cutting engagement, on the one hand, and tendency to catch, in particular with respect to reinforcement to be severed, on the other
10 hand, is achievable.

In the preferred refinement according to claim 28, the main cutting edges, the transverse cutting edge or the auxiliary cutting edges are arranged selectively on an
15 in particular single-piece cutting insert. Correspondingly, a plurality of single-piece cutting inserts can also be used here.

An above cutting insert for a masonry drill bit is the subject matter of a further teaching according to claim
20 29, to which independent importance is likewise attached.

The further teaching relates to a cutting insert for a masonry drill bit, wherein a cutting edge is provided
25 and wherein the cutting edge is formed in the usual manner by a leading rake face and by a trailing flank adjoining the rake face.

30 What is essential according to this further teaching is that an above-discussed leading ramp with respect to the rake face is provided, said ramp rising axially toward the rake face with regard to the longitudinal axis of the drill bit. Reference may be made to all
35 embodiments regarding the auxiliary cutting edges having a leading ramp.

- 6 -

In this context, it may be noted that the cutting insert according to the proposal is very particularly suitable for realizing the above-discussed auxiliary cutting edges of a masonry drill bit.

5

The invention is explained in more detail in the following text on the basis of a drawing which illustrates only one exemplary embodiment and in which:

10 figure 1 shows a side view of an exemplary embodiment of a masonry drill bit according to the proposal,

figure 2 shows a perspective view of the drill head of the masonry drill bit according to figure 1,

15 figure 3 shows a plan view of the drill head of the masonry drill bit according to figure 1,

figure 4 shows a perspective view of the cutting insert, having the main cutting edges, of the masonry drill bit according to figure 1 in the detached state, and

20

figure 5 shows a perspective view of the cutting insert, having the auxiliary cutting edge, of the masonry drill bit according to figure 1 in the detached state.

25

The masonry drill bit according to the proposal and illustrated in the drawing has a shank 1 having an insertion end 2 and a drill head 3 at the end of the shank 1 remote from the insertion end 2.

30

Figures 2 to 4 show that the drill head 3 has two main cutting edges 4, 5, which extend on both sides of the longitudinal axis 6 of the drill bit, here and preferably substantially along a main cutting axis 7.

35

The main cutting edges 4, 5 can also be oriented in an inclined manner with respect to one another as seen from above. Here, the expression "as seen from above"

- 7 -

always means the viewing direction toward the drill head 3 in the direction of the insertion end 2.

The specific realization of the main cutting edges 4, 5 plays only a subordinate role for the solution according to the proposal. This also applies for a step (figures 2 and 4) realized in the main cutting edge 5, said step not being discussed further here. In principle, it is also possible to provide more than two main cutting edges 4, 5 here.

The main cutting edges 4, 5 are each formed by a leading rake face 4a, 5a and by a trailing flank 4b, 5b adjoining the rake face 4a, 5a. In this case, the main cutting edges 4, 5 each converge toward a transverse cutting edge 8 arranged in the central region of the drill head 3.

The transverse cutting edge 8 is formed in a substantially concave manner as seen from the side (figure 4, view A). The expression "substantially concave" means that it does not necessarily have to be a curved, concave form here. Rather, it is conceivable for a concave form to be merely approximated, for example by a succession of linear sections.

The transverse cutting edge 8 is bounded by two transverse cutting ends 9, 10, which have two axially protruding transverse cutting tips 11, 12.

In the exemplary embodiment illustrated and to this extent preferred, the transverse cutting tips 11, 12 have an identical axial height. However, it is also conceivable in principle for the axial height of the two transverse cutting tips 11, 12 to be different.

What is essential now is that the transverse cutting edge 8 is formed by two adjacent channels 13, 14 and

- 8 -

that each transverse cutting tip 11, 12 is adjoined by two webs 15-18. In the exemplary embodiment illustrated, the webs 15, 16 adjoin the transverse cutting tip 11 and the webs 17, 18 adjoin the transverse cutting tip 12.

It can be seen most clearly from the illustration according to figure 4 that the webs 15-18 form edges which are provided in the above sense in addition to the main cutting edges 4, 5 and the transverse cutting edge 8. Figure 4 also shows that the webs 15-18 provide the lateral boundaries of the channels 13, 14 by the formation of these additional edges. As a result, each channel 13, 14 has a leading web 16, 17 and a trailing web 15, 18 with respect to the direction of rotation of the masonry drill bit. The direction of rotation of the illustrated masonry drill bit has been provided with the reference sign 19 in figures 2-4.

In the exemplary embodiment illustrated and to this extent preferred, the channels 13, 14 extend in a substantially straight manner. This is in any case preferred for the region close to the tips. However, it is also conceivable for the channels 13, 14 to have a curved course or the like.

The same applies to the webs 15-18. Here and preferably, the webs 15-18 are configured in a substantially straight manner at least in the region close to the tips. Here, too, a curved course or the like is conceivable.

Figure 3 shows that the main cutting edges 4, 5 in the exemplary embodiment illustrated extend substantially along the main cutting axis 7, with the channels 13, 14 extending substantially transversely to the main cutting axis 7. This is interesting especially with

- 9 -

regard to the cutting action of the webs 15-18, which is still to be explained.

As can be seen from looking at figures 2-4 together, not only the webs 15-18 but also the main cutting edges 4, 5 adjoin the transverse cutting tips 11, 12, such that a continuous cutting edge profile is produced between the two main cutting edges 4, 5 via the transverse cutting edge 8. However, it is also conceivable for the main cutting edges 4, 5 to be separated from the transverse cutting edge 8.

In the transverse cutting tips 11, 12, the angles between the main cutting edge 4, 5 and the web 15-18 are each preferably in a range between 60° and 120°.

In a particularly preferred refinement, as seen from above, the two webs 15, 16 and 17, 18 respectively adjoining a transverse cutting tip 11, 12 extend substantially in opposite directions. Here and preferably, the webs 15, 16 and 17, 18 in question even lie on a line, as seen from above. Alternatively or in addition, it is provided that, as seen from above, the two webs 15, 17 and 16, 18 of a channel 13, 14 are oriented substantially parallel to one another.

In order to be able to ensure the above-discussed concentration of force along the webs 15-18, it is advantageously provided that the channels 13, 14 are formed in a substantially concave manner in cross section (figure 4, view A). The term "concave" should be interpreted broadly, as discussed above.

In certain areas of application, it may suffice for the transverse cutting tips 11, 12 to be configured in a mound-like manner. However, here and preferably, the transverse cutting tips 11, 12 are each configured in a pointed manner in order to achieve a maximum

- 10 -

concentration of force. In this case, the rounding radius in the transverse cutting tips 11, 12 is less than about 0.9 mm and is more preferably between about 0.1 mm and about 0.9 mm.

5

In a corresponding manner, it is further preferably provided that the webs 15-18 are configured in a substantially tapering manner as seen in cross section. Specifically, in cross section, the rounding radius in the webs 15-28 is preferably under about 0.9 mm, further preferably between about 0.1 mm and about 0.9 mm.

The webs 15-18 having the resulting additional edges allow a particularly good disintegration action during hammer drilling on account of the high concentration of force along the webs 15-18. However, in addition, it can also be provided that at least one of the two webs 15-18 of a channel 13, 14 is formed as a secondary cutting edge. In the present case, the leading web 16, 17 of the channels 13, 14 is formed as a secondary cutting edge. This means firstly that in any case these webs 16, 17 are formed in a correspondingly tapering manner in cross section.

25

In order to support the action of the leading webs 16, 17 as secondary cutting edges, it is further preferably provided that the two webs 15-18 of a channel 13, 14 are set in relation to one another.

30

Preferably, the setting angle α is in the range between about 10° and about 30° . Here and preferably, the setting angle is about 20° . In a particularly preferred refinement, the two webs 15, 17 and 16, 18 of a channel 13, 14 are set in relation to one another such that the trailing web 15, 18 is located at least in part closer to the longitudinal axis 6 of the drill bit than the respectively leading web 16, 17. Further preferably,

35

- 11 -

the two webs 15, 17 and 16, 18 are set substantially only in one pivoting dimension in relation to one another, specifically about a pivot axis which is preferably oriented substantially parallel to the main cutting axis 7 or to the transverse cutting edge 8.

Advantageously, the trailing web 15, 18 is arranged with respect to the leading web 16, 17 of a channel 13, 14 such that the envelope of the movement of the trailing web 15, 18 is located at least in part, preferably substantially, within the envelope of the movement of the leading web 16, 17.

The solution according to the proposal can be applied to any conceivable masonry drill bits. In the exemplary embodiment illustrated and to this extent preferred, the masonry drill bit is equipped with two auxiliary cutting edges 20, 21, which each extend along an auxiliary cutting axis 22, 23. In principle, more than two auxiliary cutting edges 20, 21 can also be provided here. In a particularly preferred refinement, the auxiliary cutting axes 22, 23 each extend through the longitudinal axis 6 of the drill bit. However, it may also be advantageous for the auxiliary cutting edges 20, 21 to run past the longitudinal axis 6 of the drill bit.

Figure 3 shows that the auxiliary cutting edges 20, 21 are oriented substantially symmetrically with respect to the main cutting axis 7. In this case, the angle β between the respective auxiliary cutting axis 22, 23 and the main cutting axis 7 is between about 50° and about 70° . In principle, it is also possible to deviate from the symmetrical arrangement of the auxiliary cutting edges 20, 21.

What is particularly interesting in the exemplary embodiment illustrated and to this extent preferred is

- 12 -

the fact that each auxiliary cutting edge 20, 21 is formed by a leading rake face 20a, 21a and by a trailing flank 20b, 21b adjoining the rake face 20a, 21a. Figure 5 shows an insert element as such, which is
5 inserted here in duplicate in an identical form into the drill head 3 to realize the auxiliary cutting edges 20, 21.

A leading ramp 24, 25 with respect to the rake face
10 20a, 21a is provided, said ramp 24, 25 rising axially toward the rake face 20a, 21a with regard to the longitudinal axis 6 of the drill bit. The resulting ramp angle γ is shown in figure 5. The ramp angle γ is preferably in a range between about 20° and about 60° .
15 In this case, the movement vector v for the auxiliary cutting edge 20, 21 provides the reference direction for the respective ramp angle γ .

In the exemplary embodiment illustrated and to this
20 extent preferred, the ramp 24, 25 has different ramp angles γ_1 and γ_2 . Specifically, the ramp angle γ decreases toward the rake face 20a, 21a. For this purpose, the ramp 24, 25 has at least two, preferably exactly two, ramp regions 24a, 24b, 25a, 25b arranged
25 in succession, wherein the ramp angle γ_2 in the leading ramp region 24b, 25b is greater than the ramp angle γ_1 in the trailing ramp region 24a, 25a. By way of the flattened portion, provided here in two steps, of the ramp angle γ , it is possible for the trailing ramp
30 region 24a, 25a to be as wide as possible in the movement direction v , such that an optimal support for the cutting edge 20, 21 is produced. By way of the steeper, leading ramp region 24b, 25b, the remaining height difference dependent on the respective
35 constructive boundary conditions can be bridged. It may be noted that more than two above ramp regions 24a, 24b, 25a, 25b can also be provided. It may also be noted that the decrease in the ramp angle γ toward the

- 13 -

rake face 20a, 21a can proceed continuously, that is to say in a stepless manner.

Figure 5 shows that the ramp 24, 25 ends in the region
5 of the rake face 20a, 21a, here in the rake face 20a, 21a, of the auxiliary cutting edge 20, 21, wherein here and preferably, the end point 26 is set back axially from the auxiliary cutting edge 20, 21 by the height difference Δh . By way of a change in this offset Δh ,
10 the cutting engagement, on the one hand, and the tendency to catch, on the other hand, can, as explained above, be set precisely to the drilling environment to be expected. The expression "in the region of the rake face 20a, 21a" means here that the end point 26 does
15 not have to be located exactly in the rake face 20a, 21a, but can, for example, also be located beneath or also to the side of the rake face 20a, 21a.

The shape of the ramp 24, 25 can be selected in a wide
20 range. As can be seen from the illustration according to figure 5, the ramp 24, 25 is formed at least in part in a web-like manner here. With the web-like form, the sliding properties of the ramp 24, 25 can be varied. In this case, it is preferably provided that at least that
25 part of the ramp 24, 25 that is close to the rake face is formed in a web-like manner in the above sense.

In order to reduce as far as possible the friction on account of the ramp 24, 25 and the energy losses
30 associated therewith, it is provided in a further preferred refinement that, as seen from above, the web-like part of the ramp 24, 25 is configured in a curved, here and preferably circularly curved, manner. In this case, the web-like, circularly curved part is at best
35 aligned with the longitudinal axis 6 of the drill bit. This, too, can be gathered from the illustration according to figure 3.

- 14 -

With regard to the friction that occurs, on the one hand, and the resulting concentration of force on the auxiliary cutting edge 20, 21, it should be emphasized as advantageous here that the cutting edge 20, 21 is
5 slightly beveled at its two ends, this having been constructively implemented by the two bevels 29, 30.

In principle, all of the above-discussed cutting edges 4, 5, 8, 20, 21 can be realized on a single-piece drill
10 head which is then configured as a solid carbide head.

Figure 4 shows that in the exemplary embodiment illustrated the main cutting edges 4, 5 and the transverse cutting edge 8 are arranged on a here and
15 preferably single-piece cutting insert 3a, which is preferably configured as a carbide insert. The carbide insert 3a has two flat sides 27, 28, with the webs 15-18 extending as far as the flat sides 27, 28. In addition, it is provided according to figure 5 that the
20 auxiliary cutting edges 20, 21, too, are each arranged on a single-piece cutting insert 3b, 3c, which is in turn configured as a carbide insert.

The cutting inserts 3a, 3b, 3c shown in figures 4 and 5
25 are each configured in a single-piece manner. In principle, a multi-piece configuration is also conceivable here.

According to a further teaching, to which independent
30 importance is attached, the above masonry drill bit having an auxiliary cutting edge 20, 21 is claimed as such, without the realization of the first-mentioned teaching, specifically the realization of a transverse cutting edge 8 having webs 15-18, coming into question.
35 In this respect, reference may be made to all the above embodiments.

- 15 -

According to a further teaching, to which likewise independent importance is attached, a cutting insert 3b, 3c, illustrated in figure 5, having a ramp 24, 25 is claimed as such. Again, in order to explain this
5 further teaching, reference may be made to all the above embodiments.

With regard to the independently claimed cutting insert 3b, 3c, it may also be noted that this cutting insert
10 3b, 3c can be used for all conceivable types of masonry drill bits. These include in particular core drills having a cylindrical support in which a plurality of cutting inserts, which each correspond to the cutting insert 3b, 3c according to the proposal, are inserted.

- 16 -

Patent claims:

1. A masonry drill bit having a shank (1) having an insertion end (2) and a drill head (3), wherein the drill head (3) has two main cutting edges (4, 5) which extend on both sides of the longitudinal axis (6) of the drill bit, preferably substantially along a main cutting axis (7), and are each formed by a leading rake face (4a, 5a) and by a trailing flank (4b, 5b) adjoining the rake face (4a, 5a), wherein the main cutting edges (4, 5) each converge toward a transverse cutting edge (8) arranged in the central region of the drill head (3), wherein the transverse cutting edge (8) is formed in a substantially concave manner as seen from the side, is bounded by two transverse cutting ends (9, 10) and has at the two transverse cutting ends (9, 10) two transverse cutting tips (11, 12) that protrude axially with regard to the longitudinal axis (6) of the drill bit,

20 characterized

in that the transverse cutting edge (8) is formed by two adjacent channels (13, 14) and in that each transverse cutting tip (11, 12) is adjoined by two webs (15-18) which provide the lateral boundaries of the channels (13, 14) by forming additional edges, such that each channel (13, 14) has a leading web (16, 17) and a trailing web (15, 18).

2. The masonry drill bit as claimed in claim 1, characterized in that the channels (13, 14) extend in a substantially straight manner at least in a region close to the tips.

3. The masonry drill bit as claimed in claim 1 or 2, characterized in that the webs (15-18) extend in a substantially straight manner at least in a region close to the tips.

- 17 -

4. The masonry drill bit as claimed in one of the preceding claims, characterized in that the main cutting edges (4, 5) extend substantially along a main cutting axis (7), and in that the channels (13, 14)
5 extend substantially transversely to the main cutting axis (7).

5. The masonry drill bit as claimed in one of the preceding claims, characterized in that the transverse cutting tips (11, 12) are adjoined in each case by a
10 main cutting edge (4, 5), such that a continuous cutting edge profile is produced between the two main cutting edges (4, 5) via the transverse cutting edge (8).

15 6. The masonry drill bit as claimed in one of the preceding claims, characterized in that, as seen from above, the two webs (15-18) respectively adjoining a transverse cutting tip (11, 12) extend substantially in
20 opposite directions.

7. The masonry drill bit as claimed in one of the preceding claims, characterized in that, as seen from above, the two webs (15-18) of a channel (13, 14) are
25 oriented substantially parallel to one another.

8. The masonry drill bit as claimed in one of the preceding claims, characterized in that the channels (13, 14) are formed in a substantially concave manner
30 in cross section.

9. The masonry drill bit as claimed in one of the preceding claims, characterized in that the transverse cutting tips (11, 12) are each configured in a pointed
35 manner, preferably in that the rounding radius in the transverse cutting tips (11, 12) is under about 0.9 mm, more preferably between about 0.1 mm and about 0.9 mm.

- 18 -

10. The masonry drill bit as claimed in one of the preceding claims, characterized in that the webs (15-18) are configured in a substantially tapering manner in cross section, preferably in that, in cross section,
5 the rounding radius in the webs (15-18) is under about 0.9 mm, more preferably between about 0.1 mm and about 0.9 mm.

11. The masonry drill bit as claimed in one of the preceding claims, characterized in that at least in
10 each case the leading web (16, 17) of a channel (13, 14) is formed as a secondary cutting edge.

12. The masonry drill bit as claimed in one of the preceding claims, characterized in that the two webs
15 (15-18) of a channel (13, 14) are set in relation to one another, preferably in that the setting angle (α) is between about 10° and about 30° , more preferably is about 20° .

20 13. The masonry drill bit as claimed in one of the preceding claims, characterized in that the two webs (15-18) of a channel (13, 14) are set in relation to one another such that the trailing web (15, 18) is
25 located at least in part closer to the longitudinal axis (6) of the drill bit than the respectively leading web (16, 17).

30 14. The masonry drill bit as claimed in one of the preceding claims, characterized in that the trailing web (15, 18) is arranged with respect to the leading web (16, 17) of a channel (13, 14) such that the envelope of the movement of the trailing web (15, 18) is located at least in part, preferably substantially,
35 within the envelope of the movement of the leading web (16, 17).

- 19 -

15. The masonry drill bit as claimed in one of the preceding claims, characterized in that there are provided at least two auxiliary cutting edges (20, 21), which each extend along an auxiliary cutting axis (22, 23) and which are arranged, preferably in a substantially symmetrical manner, at an angle (β) to a main cutting axis (7), preferably in that the angle (β) is between about 50° and about 70° .
- 10 16. The masonry drill bit as claimed in claim 15, characterized in that each auxiliary cutting edge (20, 21) is formed by a leading rake face (20a, 21a) and by a trailing flank (20b, 21b) adjoining the rake face (20a, 21a), and in that a leading ramp (24, 25) with respect to the rake face (20a, 21a) is provided, said ramp (24, 25) rising axially toward the rake face (20a, 21a) with regard to the longitudinal axis (6) of the drill bit.
- 15 17. The masonry drill bit as claimed in claim 16, characterized in that the ramp angle (γ) is between about 20° and about 60° .
18. The masonry drill bit as claimed in claim 16 or 17, characterized in that the ramp angle (γ) decreases toward the rake face (20a, 21a), preferably in that the ramp (24, 25) has two ramp regions (24a, 24b, 25a, 25b) arranged in succession, and in that the ramp angle (γ_2) in the leading ramp region (24b, 25b) is greater than the ramp angle (γ_1) in the trailing ramp region (24a, 25a).
19. The masonry drill bit as claimed in one of claims 16 to 18, characterized in that the ramp (24, 25) ends in the region of the rake face (20a, 21a), preferably in the rake face (20a, 21a), of the auxiliary cutting edge (20, 21), preferably in that the end point (26) is set back axially from the auxiliary cutting edge (20,
- 20
25
30
35

- 20 -

21) with regard to the longitudinal axis (6) of the drill bit.

20. The masonry drill bit as claimed in one of claims 5 16 to 19, characterized in that the ramp (24, 25) is formed at least in part in a web-like manner, preferably in that at least that part of the ramp (24, 25) that is close to the rake face is formed in a web-like manner.

10

21. The masonry drill bit as claimed in claim 20, characterized in that, as seen from above, the web-like part of the ramp (24, 25) is configured in a curved, in particular circularly curved, manner, preferably in 15 that the web-like, circularly curved part is aligned with the longitudinal axis (6) of the drill bit.

22. A masonry drill bit having a shank (1) having an insertion end (2) and a drill head (3), wherein the 20 drill head (3) has two main cutting edges (4, 5) which extend on both sides of the longitudinal axis (6) of the drill bit, preferably substantially along a main cutting axis (7), wherein there are provided at least two auxiliary cutting edges (20, 21) which each extend 25 along an auxiliary cutting axis (22, 23) and which are arranged, preferably in a substantially symmetrical manner, at an angle to a main cutting axis (7),

characterized

in that each auxiliary cutting edge (20, 21) is formed 30 by a leading rake face (20a, 21a) and by a trailing flank (20b, 21b) adjoining the rake face (20a, 21a), and in that a leading ramp (24, 25) with respect to the rake face (20a, 21a) is provided, said ramp (24, 25) rising axially toward the rake face (20a, 21a) with 35 regard to the longitudinal axis (6) of the drill bit.

- 21 -

23. The masonry drill bit as claimed in claim 22, characterized in that the ramp angle (γ) is between about 20° and about 60°.

5 24. The masonry drill bit as claimed in claim 22 or 23, characterized in that the ramp angle (γ) decreases toward the rake face (20a, 21a), preferably in that the ramp (24, 25) has two ramp regions (24a, 24b, 25a, 25b) arranged in succession, and in that the ramp angle (γ_2)
10 in the leading ramp region (24b, 25b) is greater than the ramp angle (γ_1) in the trailing ramp region (24a, 25a).

25. The masonry drill bit as claimed in one of claims
15 22 to 24, characterized in that the ramp (24, 25) ends in the region of the rake face (20a, 21a), preferably in the rake face (20a, 21a), of the auxiliary cutting edge (20, 21), preferably in that the end point (26) is set back axially from the auxiliary cutting edge (20,
20 21) with regard to the longitudinal axis (6) of the drill bit.

26. The masonry drill bit as claimed in one of claims
22 to 25, characterized in that the ramp (24, 25) is
25 formed at least in part in the web-like manner, preferably in that at least that part of the ramp (24, 25) that is close to the rake face is formed in a web-like manner.

30 27. The masonry drill bit as claimed in one of claims 22 to 26, characterized in that the web-like part of the ramp (24, 25) is configured in a curved, in particular circularly curved, manner, preferably in that the web-like, circularly curved part is aligned
35 with the longitudinal axis (6) of the drill bit.

28. The masonry drill bit as claimed in one of the preceding claims, characterized in that the main

- 22 -

cutting edges (4, 5) and the transverse cutting edge (8) are arranged on an in particular single-piece cutting insert (3a), and/or in that the auxiliary cutting edges (20, 21) are each arranged on an in particular single-piece cutting insert (3b, 3c).

29. A cutting insert for a masonry drill bit, in particular for a masonry drill bit as claimed in one of claims 23 to 27, wherein a cutting edge (20, 21) is provided, wherein the cutting edge (20, 21) is formed by a leading rake face (20a, 21a) and by a trailing flank (20b, 21b) adjoining the rake face (20a, 21a),

characterized

in that a leading ramp (24, 25) with respect to the rake face (20a, 21a) is provided, said ramp (24, 25) rising axially toward the rake face (20a, 21a) with regard to the longitudinal axis (6) of the drill bit.

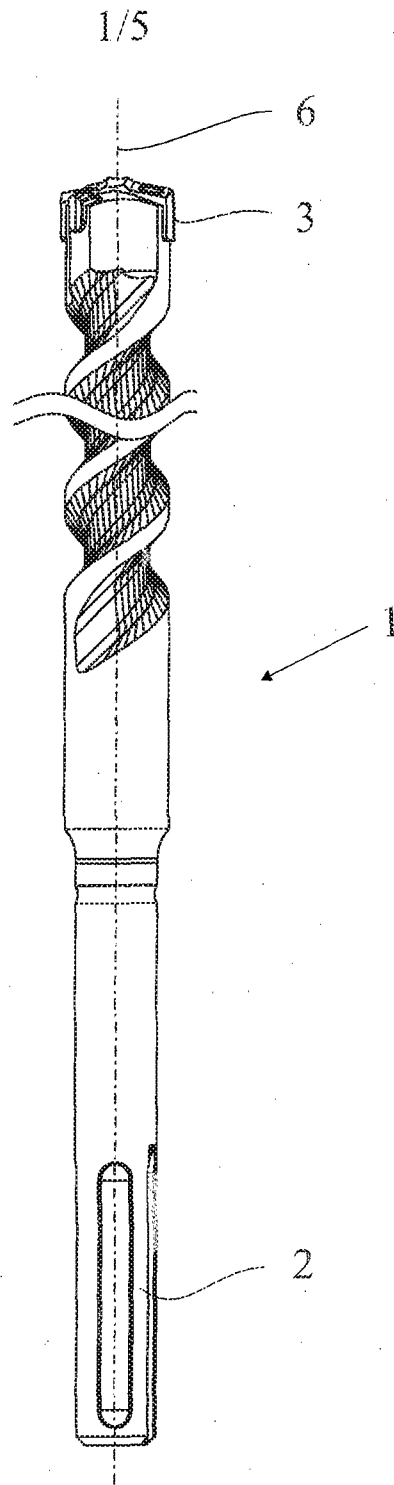

Fig. 1

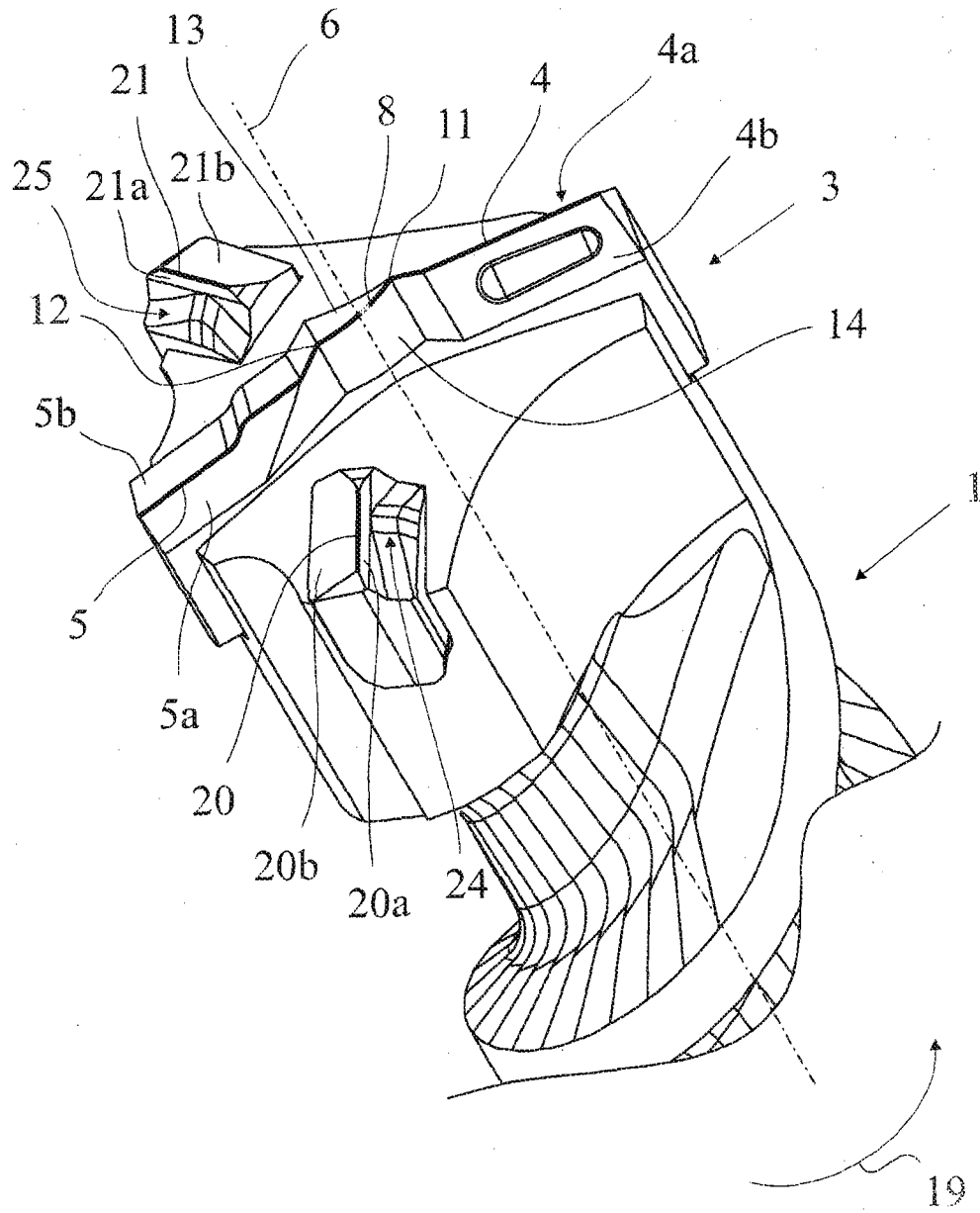

Fig. 2

3/5

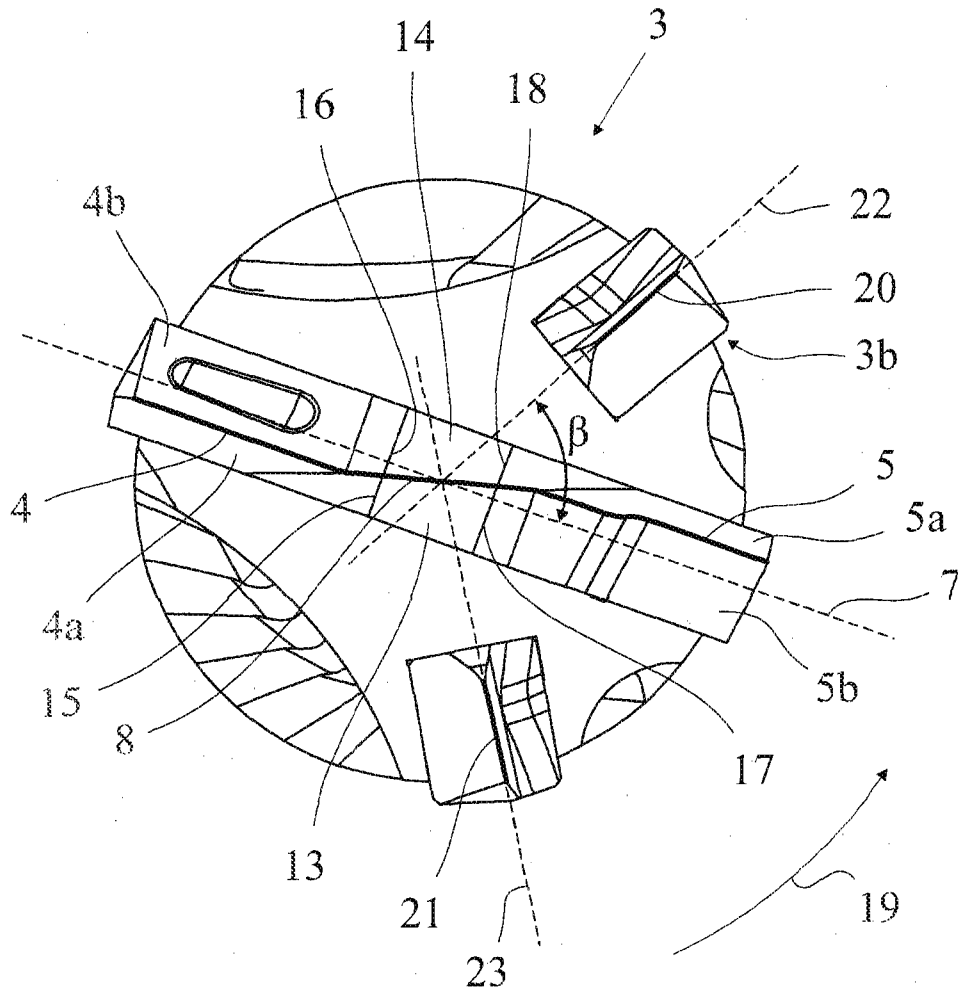

Fig. 3

4/5

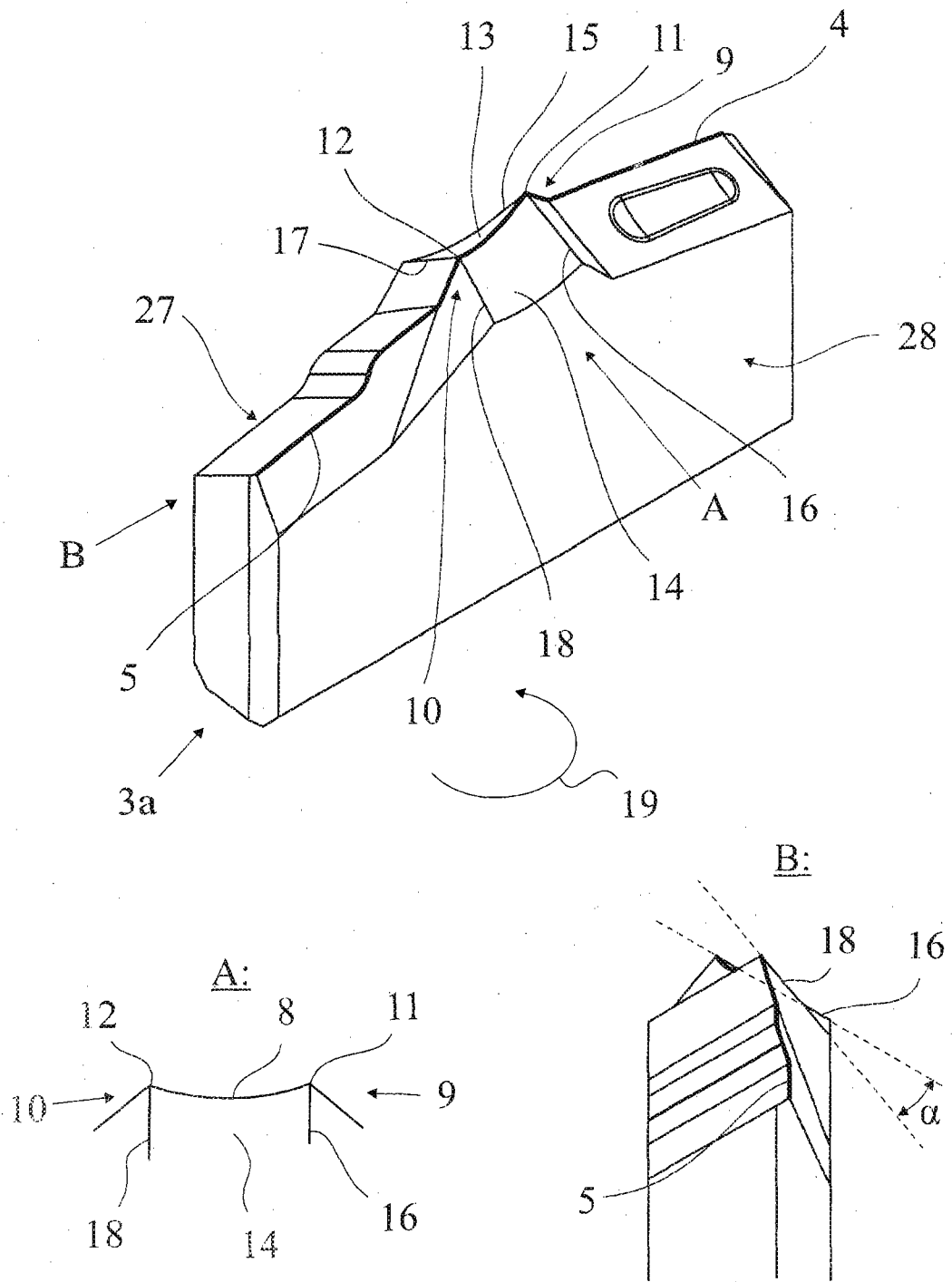

Fig. 4

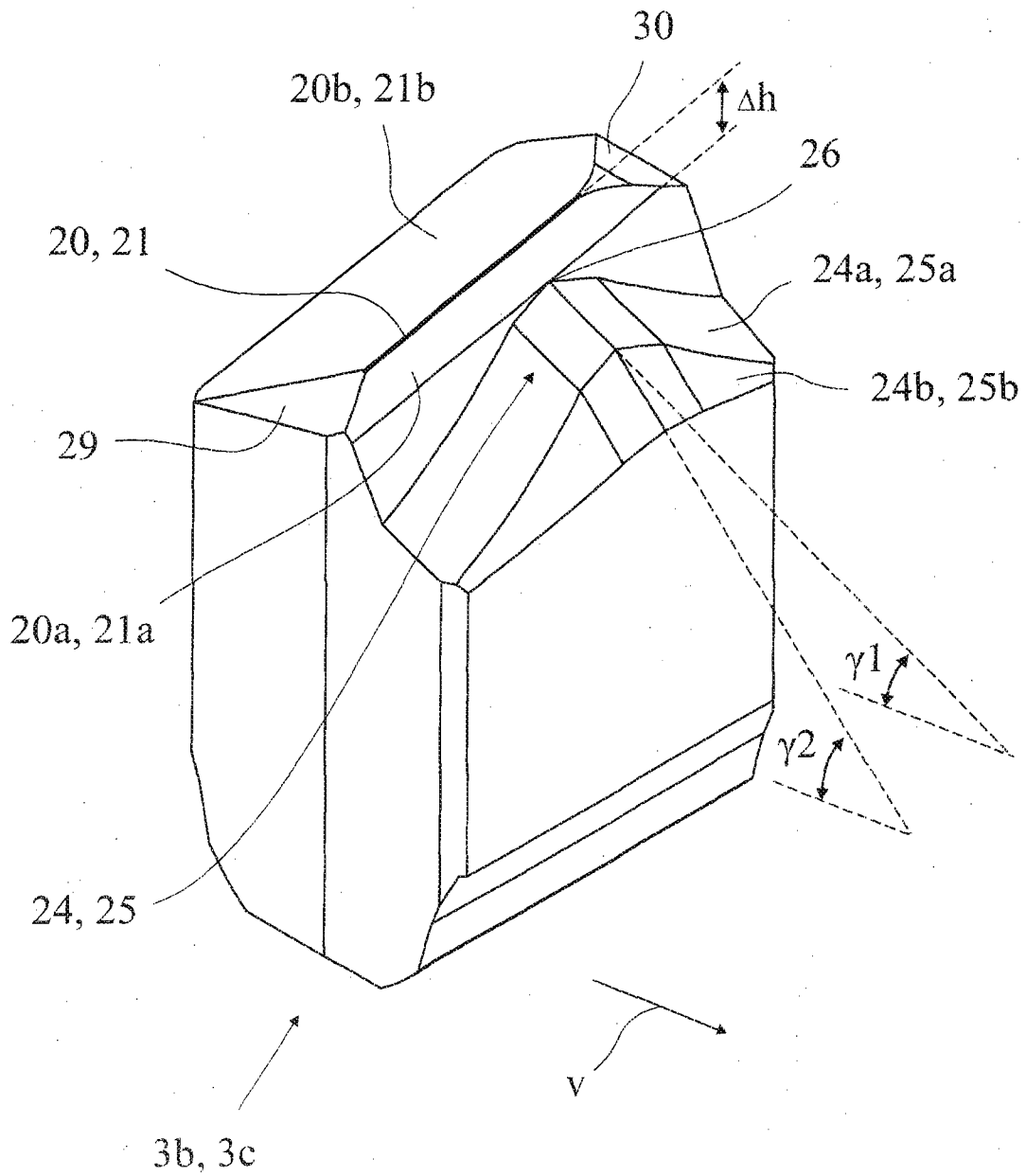

Fig. 5

INTERNATIONAL SEARCH REPORT

International application No
PCT/US2012/036730

A. CLASSIFICATION OF SUBJECT MATTER
INV. B23B51/00 B23B51/02
ADD.
According to International Patent Classification (IPC) or to both national classification and IPC

B. FIELDS SEARCHED
Minimum documentation searched (classification system followed by classification symbols)
B23B E21B

Documentation searched other than minimum documentation to the extent that such documents are included in the fields searched

Electronic data base consulted during the international search (name of data base and, where practicable, search terms used)
EPO-Internal, WPI Data

C. DOCUMENTS CONSIDERED TO BE RELEVANT

Category*	Citation of document, with indication, where appropriate, of the relevant passages	Relevant to claim No.
X	WO 99/50014 A1 (ISCAR LTD [IL]; HECHT GIL [IL]; SATRAN AMIR [IL]) 7 October 1999 (1999-10-07)	1-3,5-14
Y	claim 1; figures 1-3	15-21
X	DE 21 52 127 A1 (MEISSNER JOACHIM; SEEFLUTH UWE C) 26 April 1973 (1973-04-26) page 7, last paragraph - page 9, paragraph first; figures	1,4-6, 8-14
X	US 6 283 232 B1 (BATLINER RAINER [LT] ET AL) 4 September 2001 (2001-09-04)	22-29
Y	column 1, line 65 - column 2, line 17 column 3, line 31 - line 47; figures	15-21
A	US 6 446 741 B1 (KERSTEN HEINRICH [DE] ET AL) 10 September 2002 (2002-09-10) claim 1; figures 3a-3d	1
	----- -/--	

Further documents are listed in the continuation of Box C.

See patent family annex.

* Special categories of cited documents :

- "A" document defining the general state of the art which is not considered to be of particular relevance
- "E" earlier application or patent but published on or after the international filing date
- "L" document which may throw doubts on priority claim(s) or which is cited to establish the publication date of another citation or other special reason (as specified)
- "O" document referring to an oral disclosure, use, exhibition or other means
- "P" document published prior to the international filing date but later than the priority date claimed

- "T" later document published after the international filing date or priority date and not in conflict with the application but cited to understand the principle or theory underlying the invention
- "X" document of particular relevance; the claimed invention cannot be considered novel or cannot be considered to involve an inventive step when the document is taken alone
- "Y" document of particular relevance; the claimed invention cannot be considered to involve an inventive step when the document is combined with one or more other such documents, such combination being obvious to a person skilled in the art
- "&" document member of the same patent family

Date of the actual completion of the international search 29 June 2012	Date of mailing of the international search report 05/07/2012
---	--

Name and mailing address of the ISA/ European Patent Office, P.B. 5818 Patentlaan 2 NL - 2280 HV Rijswijk Tel. (+31-70) 340-2040, Fax: (+31-70) 340-3016	Authorized officer Barrow, Jeffrey
--	---

INTERNATIONAL SEARCH REPORT

International application No.
PCT/US2012/036730

Box No. II Observations where certain claims were found unsearchable (Continuation of item 2 of first sheet)

This international search report has not been established in respect of certain claims under Article 17(2)(a) for the following reasons:

1. Claims Nos.:
because they relate to subject matter not required to be searched by this Authority, namely:

2. Claims Nos.:
because they relate to parts of the international application that do not comply with the prescribed requirements to such an extent that no meaningful international search can be carried out, specifically:

3. Claims Nos.:
because they are dependent claims and are not drafted in accordance with the second and third sentences of Rule 6.4(a).

Box No. III Observations where unity of invention is lacking (Continuation of item 3 of first sheet)

This International Searching Authority found multiple inventions in this international application, as follows:

see additional sheet

1. As all required additional search fees were timely paid by the applicant, this international search report covers all searchable claims.
2. As all searchable claims could be searched without effort justifying an additional fees, this Authority did not invite payment of additional fees.
3. As only some of the required additional search fees were timely paid by the applicant, this international search report covers only those claims for which fees were paid, specifically claims Nos.:

4. No required additional search fees were timely paid by the applicant. Consequently, this international search report is restricted to the invention first mentioned in the claims; it is covered by claims Nos.:

Remark on Protest

- The additional search fees were accompanied by the applicant's protest and, where applicable, the payment of a protest fee.
- The additional search fees were accompanied by the applicant's protest but the applicable protest fee was not paid within the time limit specified in the invitation.
- No protest accompanied the payment of additional search fees.

INTERNATIONAL SEARCH REPORT

International application No
PCT/US2012/036730

C(Continuation). DOCUMENTS CONSIDERED TO BE RELEVANT		
Category*	Citation of document, with indication, where appropriate, of the relevant passages	Relevant to claim No.
A	EP 0 965 405 A2 (HILTI AG [LI]) 22 December 1999 (1999-12-22) figure 3 -----	15-29
A	US 2002/053473 A1 (KNOLLER ANTON [DE]) 9 May 2002 (2002-05-09) paragraph [0017] - paragraph [0018] paragraph [0025]; figures -----	15-29
A	DE 20 2008 017395 U1 (MAPAL FAB PRAEZISION [DE]) 16 July 2009 (2009-07-16) figures 1,2 -----	28

INTERNATIONAL SEARCH REPORT

Information on patent family members

International application No PCT/US2012/036730

Patent document cited in search report	Publication date	Patent family member(s)	Publication date
WO 9950014	A1	07-10-1999	
		AU 2744799 A	18-10-1999
		DE 19983068 B4	23-04-2009
		DE 19983068 T1	10-05-2001
		IL 123858 A	29-05-2003
		JP 3827062 B2	27-09-2006
		JP 2002509810 A	02-04-2002
		US 6071046 A	06-06-2000
		WO 9950014 A1	07-10-1999

DE 2152127	A1	26-04-1973	NONE

US 6283232	B1	04-09-2001	
		AT 300660 T	15-08-2005
		CN 1270882 A	25-10-2000
		DE 19916975 A1	19-10-2000
		DK 1045112 T3	31-10-2005
		EP 1045112 A1	18-10-2000
		JP 4627838 B2	09-02-2011
		JP 2000309014 A	07-11-2000
		US 6283232 B1	04-09-2001

US 6446741	B1	10-09-2002	
		DE 19964272 C2	28-05-2003
		GB 2356164 A	16-05-2001
		US 6446741 B1	10-09-2002

EP 0965405	A2	22-12-1999	
		DE 19827536 A1	23-12-1999
		EP 0965405 A2	22-12-1999

US 2002053473	A1	09-05-2002	
		CH 695212 A5	31-01-2006
		CN 1350914 A	29-05-2002
		DE 10053344 A1	08-05-2002
		JP 2002178329 A	26-06-2002
		SE 522753 C2	02-03-2004
		SE 0103459 A	28-04-2002
		US 2002053473 A1	09-05-2002

DE 202008017395	U1	16-07-2009	NONE

FURTHER INFORMATION CONTINUED FROM PCT/ISA/ 210

This International Searching Authority found multiple (groups of) inventions in this international application, as follows:

1. claims: 1-21

Cutting edge of a masonry drill bit

2. claims: 22-29

Auxiliary cutting edge for a masonry drill bit; Cutting insert for an auxiliary cutting edge for a masonry drill bit
