



(11) **EP 2 886 200 B1**

(12) **EUROPEAN PATENT SPECIFICATION**

(45) Date of publication and mention of the grant of the patent:
23.09.2020 Bulletin 2020/39

(51) Int Cl.:
B05C 5/02 ^(2006.01) **B05C 11/10** ^(2006.01)
B42C 9/00 ^(2006.01)

(21) Application number: **13198194.6**

(22) Date of filing: **18.12.2013**

(54) **Device and method for intermittently applying a liquid material, in particular foamed adhesive onto a substrate**

Vorrichtung und Verfahren zum intermittierenden Auftragen eines flüssigen Materials, insbesondere von geschäumtem Klebstoff auf ein Substrat

Dispositif et procédé pour appliquer de façon intermittente un matériau liquide, en particulier un adhésif mousse sur un substrat

(84) Designated Contracting States:
AL AT BE BG CH CY CZ DE DK EE ES FI FR GB GR HR HU IE IS IT LI LT LU LV MC MK MT NL NO PL PT RO RS SE SI SK SM TR

(74) Representative: **Eisenführ Speiser**
Patentanwälte Rechtsanwälte PartGmbB
Postfach 10 60 78
28060 Bremen (DE)

(43) Date of publication of application:
24.06.2015 Bulletin 2015/26

(56) References cited:
EP-A1- 2 319 707 EP-A2- 2 390 011
EP-A2- 2 684 702 JP-A- 2006 278 183
JP-A- 2007 253 013 US-A1- 2002 053 406
US-A1- 2004 062 866 US-A1- 2008 166 207
US-A1- 2011 259 265 US-A1- 2013 277 457

(73) Proprietor: **Nordson Corporation**
Westlake, OH 44145 (US)

(72) Inventor: **Lübbecke, Kai**
21357 Wittorf (DE)

EP 2 886 200 B1

Note: Within nine months of the publication of the mention of the grant of the European patent in the European Patent Bulletin, any person may give notice to the European Patent Office of opposition to that patent, in accordance with the Implementing Regulations. Notice of opposition shall not be deemed to have been filed until the opposition fee has been paid. (Art. 99(1) European Patent Convention).

Description

[0001] The present invention relates to a device and method for intermittently applying a liquid material, in particular foamed adhesive, onto a substrate.

[0002] Such devices and methods are used in various industrial sectors to apply adhesives, sealants or other technical flowable materials onto a variety of different substrates such as films, packaging materials, machine parts or other work pieces.

[0003] The device and the method according to the present invention especially relates to surface applications, wherein a closed layer of liquid material has to be applied onto the substrate for use in the manufacture of products. While the device and the method according to the present invention can be used in the manufacture of many different types of products one example is for use in the bookbinding industry to apply adhesive onto the spine of a book.

[0004] The requirements to liquid materials are rising together with the quality expectations of the customers of the produced products. The improvements of the material's properties are associated by rising material prices. Thus, efficient production techniques are needed to compensate the rising material price.

[0005] Therefore, various industry branches adapted their production equipment in order to use foamed materials, especially foamed adhesives. It has been found that foaming of adhesive does not lead to disadvantages in bonding quality for a variety of materials. The use of foamed adhesive leads to material savings and therefore to lower production costs.

[0006] However, the use of foamed adhesives brings along a major disadvantage. The foamed materials tend to expand in volume and therefore a precise application of the foamed material onto the substrate is hampered. Especially realizing a proper cut-off in surface application cannot always be provided by means of the known application devices.

[0007] In surface application devices foamed material is forced to flow through a slot shaped discharge channel or discharge slot in order to be discharged through a discharge opening onto a substrate. After the flow of foamed material has been interrupted by means of a closing (or valve) element, residual material remains between the closing element and the discharge opening. The expansion of the foamed material causes an improper after-flow on the application product and therefore an improper material cut-off is caused.

[0008] Such a device for bookbinding applications having a slot nozzle for dispensing the foamed adhesive onto a book's spine is disclosed in EP 1 419 900 B1.

[0009] Other coating devices are disclosed in JP 2007 253013 A, US 2013/277457, EP 2 319 707 A1 and US 2002/053406 A1, US 2008/0166207 A1 and US 2004/0062866 A1.

[0010] The object of the present invention is therefore to provide a device and a method for intermittently ap-

plying a foamed material onto a substrate allowing for an improved material application, especially allowing for a proper material cut-off in surface applications.

[0011] Thus, according to the invention, a device of the initially mentioned type is proposed, having the features of claim 1.

[0012] The invention makes use of the fact that foamed material cannot cause an improper material cut-off through material expansion while interrupting the flow of material, when the material located in the discharge slot or channel between the discharge opening and the rotatable valve member is sucked back before the rotatable valve member interrupts the flow of material. Since there is no expandable foamed material left between the discharge opening and the rotatable valve member while interrupting the flow of liquid material by means of the rotatable valve member, there is no or reduced risk that expanding material causes an undesired after-flow onto the application product.

[0013] According to the invention the rotatable valve member is a cylindrical rod and has at least one slot-shaped passageway. In the first position of the rotatable valve member the slot-shaped passageway is aligned in-line with the internal fluid chamber, such that fluid communication between the internal fluid chamber and the discharge opening is established. Through the cylindrically shaped rod a rotary valve function can be obtained while the cylindrical rod cooperates with a cylindrically shaped cavity in the housing. A lateral surface of the cylindrically shaped cavity functions as a valve seat for the rotatable valve member. By means of an elongate cylindrical rod having a slot shaped passageway a valve for a slot nozzle is provided which is capable of instantly interrupting and allowing for flow of a liquid material over the entire length of the slot or discharge channel, respectively, without displacing the fluid.

[0014] In an embodiment of the device according to the invention the rotatable valve member is disposed adjacent to the discharge opening. Adjacent in the meaning of this invention has to be understood in the way that there is no other functional component between the discharge opening and the rotatable valve member, except the discharge channel or a part of the discharge channel that allows for fluid communication between the rotatable valve member and the discharge opening.

[0015] It is further preferred that the rotatable valve member is disposed in a downstream direction relative to the first moveable member. This leads to the effect that the material located between the discharge opening and the rotatable valve member is sucked into or through the passageway of the rotatable valve member while the first moveable member moves from the first downstream position to the second upstream position.

[0016] In another preferred embodiment of the device according to the invention the discharge channel is at least partially disposed between the discharge opening and the rotatable valve member. Further it is preferred that the device is adapted such that the volume released

by the movement of the first moveable member from the first downstream position to the second upstream position equals the volume of the discharge channel between the discharge opening and the rotatable valve member. This leads to the effect, that a movement of the first moveable member from the first downstream position to the second upstream position completely empties the discharge channel between the discharge opening and the rotatable valve member. In an alternative, the device according to the invention is adapted such that the volume released by the movement of the first moveable member from the first downstream position to the second upstream position is greater than the volume of the discharge channel between the discharge opening and the rotatable valve member.

[0017] In another preferred embodiment of the device according to the invention a first pneumatically and/or electrically actuated driving device is coupled to the first moveable member to move the first moveable member back and forth. By moving the first moveable member back and forth the first downstream position as well as the second upstream position can be adjusted. The first pneumatically and/or electrically actuated driving device can comprise, for instance, a diaphragm pneumatic actuator, a pneumatic power cylinder, an electrical linear actuator, a rotationally drive having a transmission or a magnetic actuator. In an alternative embodiment the first driving device can also be hydraulically and/or mechanically actuated.

[0018] In another preferred embodiment of the device according to the invention a second driving device is coupled with the rotatable valve member. It is preferred that the second driving device is a rotating pneumatic, hydraulic or electric drive or a pneumatic, hydraulic or electric linear drive.

[0019] Another preferred embodiment of the device according to the invention comprises adjustment means adapted to adjust the effective length and/or the effective width and/or the effective shape of the discharge opening. By means of such adjustment means the device can be used to apply various sizes and/or shapes of surfaces onto substrates. In the bookbinding industry, for example, such adjustment means allow for applying foamed adhesive onto a variety of a different book sizes and/or shapes. The adjustment means are disposed adjacent to the discharge opening and can be moved such that a surface or surfaces of the adjustment means cover the discharge opening in a way preventing a flow of liquid material through the covered locations. The adjustment means may be moveably and detachably coupled with the housing. Guiding means as well as mounting means may be provided in order to precisely adjust the adjustment means and to fix the adjustment means at the desired location. The adjustment means further may have lateral recesses which are in fluid communication with a discharge opening. Such lateral recesses are used in the bookbinding process to extend the surface of discharged foamed adhesive over the edges of the book spine. This

leads to an improved stability of the bound book as well as to an extended life span and increased durability of the binding.

[0020] In another preferred embodiment of the device according to the invention a volume compensation channel and a moveable displacement element are provided, wherein the moveable displacement element is at least partially moveable within the volume compensation channel. The volume of the volume compensation channel is adaptable by the movement of the displacement element. Especially in combination with the use of adjustment means such a volume compensation is required in order to adjust for the right amount of liquid material to be dispensed.

[0021] In another preferred embodiment of the device according to the invention the housing comprises at least a first part and a second part, wherein the first part and the second part are detachably coupled to each other, leading to various advantages. The maintenance and the repair of the device are considerably simplified. Broken and/or inoperative components may be easily replaced through a replacement of an entire part of the housing in which the broken or inoperative component is mounted. Cloggings and/or deposits which may have a negative effect on the application function or the application precision can be removed by easily disassembling the housing. Furthermore, the manufacturing process and therefore also the manufacturing costs can be reduced by a two-part or multi-part design of the housing. Complex passageway-structures enabling for fluid communication within the housing can be, for instance, realized as grooves on one side of a first housing part. A second housing part can be placed against the surface of the first housing part featuring the grooves in order to realize a complex system of passageways allowing for fluid communication.

[0022] In another preferred embodiment of the device according to the invention the first moveable member is disposed in the second part of the housing and/or the rotatable valve member is disposed partially in the first part and partially in the second part of the housing and/or the internal fluid chamber is disposed partially in the first part and partially in the second part of the housing and/or the volume compensation channel is disposed partially in the first part and partially in the second part of the housing and/or the slot nozzle is disposed between the first part and the second part of the housing.

[0023] In another example of the device, the rotatable valve member is adapted to rotate just in one rotational direction such that the rotation from the first position into the second position has the same rotational direction as the rotation from the second position into the first position. Since the first position and the second position of the rotatable valve member can be obtained by rotating the rotatable valve member in just one rotational direction, the cycle time can be adapted by modifying the rotational speed of the rotational valve member.

[0024] The above cited object of the present invention

is also solved by a method according to claim 11.

[0025] Regarding the advantages of the method according to the invention it is referred to the advantages presented in reference to the device according to the invention.

[0026] A first preferred embodiment of the method according to the invention comprises the steps decreasing the volume of the internal fluid chamber by the predetermined volume, and re-establishing fluid communication between the internal fluid chamber and the discharge opening, preferably before, during or after the volume of the internal fluid chamber is decreased by the predetermined volume.

[0027] In another example of the method, the predetermined volume is equal to or greater than a volume of the discharge channel between the discharge opening and the rotatable valve member. This leads to an entirely emptied discharge channel between the discharge opening and the rotatable valve member after the volume of the internal fluid chamber is increased and the fluid material is sucked in upstream direction.

[0028] In another preferred embodiment of the method according to the invention increasing the volume of the internal fluid chamber by a predetermined volume comprises moving a first movable member being disposed at least partially within the internal fluid chamber from a first downstream position into a second upstream position and/or moving the first movable member at least partially out of the internal fluid chamber.

[0029] Another embodiment of the method according to the invention comprises the step adjusting the effective length and/or the effective width and/or the effective size of the discharge opening.

[0030] Yet another embodiment of the method according to the invention comprises the step applying adhesive onto a spine of a book. The quality of bookbindings can be improved considerably by using the method according to the invention. Furthermore, the cycle times can be increased and the required amount of adhesive per binding can be reduced.

[0031] Below, the invention is described in greater detail with reference to preferred embodiments and to the drawings in the figures. The drawings show in:

- Fig. 1 a perspective view of an embodiment of the device according to the invention;
- Fig. 2 a perspective view of another embodiment of the device according to the invention;
- Fig. 3 a perspective view of yet another embodiment of the device according to the invention;
- Fig. 4 a front view of an embodiment of the device according to the invention showing parts of the device in a cross-sectional view;
- Fig. 5 a front view of the embodiment illustrated in Fig. 4 also showing parts of the device in a cross-sectional view;
- Fig. 6 a detailed cross-sectional view of parts of the

- Fig. 7 a cross-sectional side view of an embodiment of the device according to the invention;
- Fig. 8 a detailed cross-sectional side view of the embodiment illustrated in Fig. 7;
- Fig. 9 a cross-sectional side view of an embodiment of the device according to the invention;
- Fig. 10 a detailed cross-sectional side view of the embodiment illustrated in Fig. 9;
- Fig. 11 a cross-sectional side view of an embodiment of the device according to the invention;
- Fig. 12 a detailed cross-sectional side view of the embodiment illustrated in Fig. 11, and
- Fig. 13 a schematic block diagram of an embodiment of the method according to the invention.

[0032] Fig. 1 provides a perspective view of an embodiment of the device according to the invention. The shown device 1 for intermittently applying a liquid material onto a substrate is a device used in the industrial sector of book binding for applying a surface of foamed adhesive on a book's spine. The housing 2 has an internal fluid chamber 6 (not shown), which is in fluid communication with a discharge opening 12 when a rotatable valve member 14 is in a first position. While the rotatable valve member 14 is in the first position liquid material can flow from the internal fluid chamber through a discharge channel 10 or slot 10 opening 12 in order to be applied onto the substrate.

[0033] The discharge channel 10 and the discharge opening 12 are part of a slot nozzle 8. The effective length and/or the effective width and/or the effective shape of the discharge opening 12 can be adjusted by means of adjustment means 22a, 22b. The adjustment means 22a, 22b are coupled with a hand wheel 23 through transmission means 25. By rotating the hand wheel 23 the device 1 can be configured to different book sizes and spine sizes, respectively. The rotatable valve member 14 is actuated by means of a rotating pneumatic drive 20. The rotary movement generated by the rotating pneumatic drive 20 is transferred to the rotatable valve member 14 through a gear box 21 having an adjustable transmission ratio. By rotating the rotatable valve member 14 from the first position into a second position the fluid communication between the internal fluid chamber and the discharge opening 12 is interrupted.

[0034] Fig. 2 and Fig. 3 illustrate similar embodiments of a device according to the invention. The device shown in the perspective view of Fig. 2 features a pneumatic linear drive that causes the rotatable movement of the rotatable valve member 14. Therefore, transmission elements are used in order to convert the linear movement of the pneumatic linear drive into a rotational movement of the rotatable valve member 14. The perspective view of the embodiment of the device shown in Fig. 3 differs from the embodiment illustrated in Fig. 1 in that the gear box 21 is belt-driven such that the transmission ratio between the second driving device 20 and the rotatable

valve member 14 is fixed.

[0035] The cross-sectional view in Fig. 4 shows a device without liquid material. The rotatable valve member 14 is a cylindrical rod and has a slot-shaped passageway 16. The slot-shaped passageway 16 is capable of establishing fluid communication between the discharge opening 12 and the internal fluid chamber. The fluid communication is established while the rotatable valve member 14 is in the first position. In the first position of the rotatable valve member the liquid material is forced to flow from the internal fluid chamber through the discharge channel to the discharge opening 12 in order to be applied onto the substrate. A cylindrically shaped volume compensation channel 24 is disposed in the housing 2 of the device 1.

[0036] Fig. 5 illustrates a cross-sectional view of a device that is coupled to a source of liquid material. In the illustrated configuration of the device 1, fluid communication between volume compensation channel 24, internal fluid chamber and slot nozzle is established. The rotatable valve member 14 is partially disposed within the slot nozzle 8.

[0037] The cross-sectional view of Fig. 6 illustrates the direction of flow the liquid material from the volume compensation channel 24 through the internal fluid chamber 6, the discharge channel 10b, the slot-shaped passageway 16 of the rotatable valve member 14, the discharge channel 10a to the discharge opening 12 in greater detail. The discharge opening 12 and the discharge channels 10a, 10b are part of the slot nozzle 8. In the shown configuration the rotatable valve member 14 is in the first position and therefore fluid communication between the internal fluid chamber 6 and the discharge opening 12 is established.

[0038] Fig. 7 illustrates a cross-sectional side view of an embodiment of the device according to the invention. A first moveable member 4 is at least partially disposed within the internal fluid chamber 6. The first moveable member 4 is capable of moving back and forth and thereby capable of moving between a first downstream position and a second upstream position. In the shown configuration the first moveable member 4 is in the first downstream position. The first moveable member 4 is actuated by a first driving device 18. The driving device allows for linear movement of the first moveable member 4 within the internal fluid chamber 6. It is also shown that the housing of the device 1 comprises a first part 2a and a second part 2b. The first moveable member 4 is disposed in the second part 2b of the housing. The rotatable valve member 14, the internal fluid chamber 6 and the volume compensation channel 24 are disposed partially in the first part 2a and partially in the second part 2b of the housing. The slot nozzle 8 is disposed between the first part 2a and the second part 2b of the housing. In the shown configuration the rotatable valve member 14 is in the first position, such that the discharge opening 12 is in fluid communication with the internal fluid chamber 6.

[0039] The detailed cross-sectional view of Fig. 8 illus-

trates that the slot-shaped passageway 16 of the rotatable valve member 14 is coupled with the discharge opening 12 by the discharge channel 10a. The slot-shaped passageway 16 of rotatable valve member 14 is connected to the internal fluid chamber 6 by the discharge channel 10b.

[0040] Fig. 9 shows the first moveable member in the second upstream position. Through the movement of the first moveable member 4 from the first downstream position to the second upstream position fluid material within the internal fluid chamber 6 is at least partially moved into an upstream direction. The movement of the fluid material in the upstream direction is caused by an enlargement of the volume of the internal fluid chamber through the movement of the first moveable member 4 from the first downstream position into the second upstream position.

[0041] Fig. 10 shows that the liquid material that has been in the discharge channel 10a between a discharge opening 12 and the rotatable valve member 14 (see Fig. 8) is entirely sucked into the slot-shaped passageway 16 of the rotatable valve member 14.

[0042] Fig. 11 and Fig. 12 show the device 1 after the rotatable valve member is been rotated from the first position to the second position. Since the slot-shaped passageway of the rotatable valve member 14 is not aligned in-line with the discharge channel 10a, 10b, the fluid communication between the internal fluid chamber 6 and the discharge opening 12 is interrupted.

[0043] Fig. 13 shows a schematic block diagram of an embodiment of the method according to the invention. Preferably, the method makes use of the devices described above and/or in the claims.

[0044] The first step of the illustrated step is forcing the liquid material flow from the internal fluid chamber through the discharge channel and the discharge opening 102. This step is followed by increasing the volume of the internal fluid chamber by a predetermined volume 104. Increasing the volume of the internal fluid chamber by a predetermined volume 104 can comprise the step moving a first moveable member, which is disposed at least partially within the internal fluid chamber from a first downstream position into a second upstream position 105a and/or the step moving the first moveable member at least partially out of the internal fluid chamber 105b. Subsequently the step interrupting fluid communication between the internal fluid chamber and the discharge opening 106 is performed, wherein interrupting fluid communication between the internal fluid chamber and the discharge opening 106 can comprise rotating a rotatable valve member from a first position into a second position 107. This step is followed by the steps decreasing the volume of the internal fluid chamber by the predetermined volume 108, re-establishing fluid communication between the internal fluid chamber and the discharge opening 110 and adjusting the effective length and/or the effective width and/or the effective size of the discharge opening 112.

Reference numeral list:

[0045]

1	device	5
2	housing	
2a, 2b	first and second part of the housing	
4	first movable member	
6	internal fluid chamber	
8	slot nozzle	10
10, 10a, 10b	discharge channel or discharge slot	
12	discharge opening	
14	rotatable valve member	
16	slot-shaped passageway	
18	first driving device	15
20	second driving device	
21	gear box	
22a, 22b	adjustment means	
23	hand wheel	
24	volume compensation channel	20
25	transmission means	

Claims

1. Device (1) for intermittently applying a liquid material, in particular foamed adhesive, onto a substrate, comprising:

a housing (2) having an internal fluid chamber (6);
 a first movable member (4) being at least partially moveable within said internal fluid chamber (6) between a first downstream position and a second upstream position, such that fluid within said internal fluid chamber is at least partially moved into an upstream direction when said movable member moves upstream;
 a nozzle (8) having a discharge channel (10, 10a, 10b) and a discharge opening (12) communicating with said discharge channel (10, 10a, 10b); and
 a rotatable valve member (14) being rotatable between a first position, in which said internal fluid chamber (6) being in fluid communication with said discharge opening (12), wherein the liquid material flows from said internal fluid chamber (6) through said discharge channel (10, 10a, 10b) and said discharge opening (12), and a second position, in which said internal fluid chamber (6) not being in fluid communication with said discharge opening (12)
 wherein the nozzle (8) is a slot nozzle, and said rotatable valve member (14) is a cylindrical rod and has at least one slot-shaped passageway (16), and
characterized in that through movement of the first moveable member (4) from the first down-

stream position to the second upstream position fluid material within the internal fluid chamber (6) is at least partially moved into an upstream direction and liquid material that has been in the discharge channel (10, 10a, 10b) between the discharge opening (12) and the rotatable valve member (14) is entirely sucked into the slot-shaped passageway (16) of the rotatable valve member (14).

2. Device (1) according to claim 1, **characterized in that** said rotatable valve member (14) is disposed adjacent to said discharge opening (12) and/or disposed in a downstream direction relative to said first movable member (4).
3. Device (1) according to one of the preceding claims, **characterized in that** said discharge channel (10, 10a) is at least partially disposed between said discharge opening (12) and said rotatable valve member (14).
4. Device according to claim 1, **characterized in that** said first movable member (4) is movable within a side channel communicating with said internal fluid chamber (6), preferably with a distribution channel for distributing fluid into said discharge slot (10, 10a, 10b).
5. Device (1) according to one of the preceding claims, **characterized in that** a first pneumatically and/or electrically and/or hydraulically actuated driving device (18) is coupled to said first movable member (4) to move said first movable member (4) back and forth.
6. Device (1) according to one of the preceding claims, **characterized in that** a second driving device (20) is coupled to said rotatable valve member (14), said second driving device (20) preferably being a rotating pneumatic, hydraulic and/or electric drive or a pneumatic, hydraulic and/or electric linear drive.
7. Device (1) according to one of the preceding claims, **characterized by** adjustment means (22a, 22b) adapted to adjust the effective length and/or the effective width and/or the effective shape of said discharge opening (12).
8. Device (1) according to one of the preceding claims, **characterized by** a volume compensation channel (24) and a movable displacement element at least partially moveable within said volume compensation channel (24), wherein the volume of said volume compensation channel (24) being adaptable by the movement of said displacement element.
9. Device (1) according to one of the preceding claims,

characterized in that said housing (2) comprises at least a first part (2a) and a second part (2b), wherein said first part (2a) and said second part (2b) being detachably coupled to each other or to an adapter element.

10. Device (1) according to claim 9,
characterized in that said first movable member (4) is disposed in said second part (2b) and/or said rotatable valve member (14) is disposed partially in said first part (2a) and partially in said second part (2b)
 and/or said internal fluid chamber (6) is disposed partially in said first part (2a) and partially in said second part (2b)
 and/or said volume compensation channel (24) is disposed partially in said first part (2a) and partially in said second part (2b)
 and/or said slot nozzle (8) is disposed between said first part (2a) and said second part (2b).

11. Method (100) for intermittently applying a liquid material, in particular foamed adhesive, onto a substrate, using the dispensing device (1) according to at least one of the claims 1-10, comprising the steps:

forcing (102) the liquid material to flow from said internal fluid chamber (6) through said discharge channel (10, 10a, 10b) and said discharge opening (12);
 increasing the volume (104) of said internal fluid chamber (6) by a predetermined volume; and
 interrupting (106) fluid communication between said internal fluid chamber (6) and said discharge opening (12) after the volume of said internal fluid chamber (6) being increased by the predetermined volume (104) by rotating the rotatable valve member (14) comprising a cylindrical rod with at least one slot-shaped passage-way (16) from a first position into a second position (107).

12. Method (100) according to claim 11, comprising the steps:

decreasing the volume (108) of said internal fluid chamber (6) by said predetermined volume; and
 re-establishing fluid communication (110) between said internal fluid chamber (6) and said discharge opening (12).

13. Method (100) according to claim 11 or 12,
characterized in that said predetermined volume is equal to a volume of said discharge channel (10, 10a, 10b) between said discharge opening (12) and said rotatable valve member (14).

14. Method (100) according to one of the claims 11 to 13,

characterized in that increasing the volume (104) of said internal fluid chamber (6) by a predetermined volume comprises:

moving the first movable member (4) that is disposed at least partially within said internal fluid chamber (6) from a first downstream position into a second upstream position (105a) and/or moving said first movable member (4) at least partially out of said internal fluid chamber (105b).

15. Method (100) according to one of the claims 11 to 14, comprising the step:
 adjusting (112) the effective length and/or the effective width and/or the effective size of said discharge opening (12).

16. Method (100) according to one of the claims 11 to 15, comprising the step:
 applying adhesive onto a spine of a book.

Patentansprüche

1. Gerät (1) zum intermittierenden Auftragen eines flüssigen Materials, insbesondere eines geschäumten Klebstoffs, auf ein Substrat, umfassend:

ein Gehäuse (2) mit einer inneren Fluidkammer (6);
 ein erstes bewegbares Element (4), das zumindest teilweise innerhalb der inneren Fluidkammer (6) zwischen einer ersten stromabwärtigen Position und einer zweiten stromaufwärtigen Position bewegbar ist, so dass das Fluid innerhalb der inneren Fluidkammer zumindest teilweise in eine stromaufwärtige Richtung bewegt wird, wenn sich das bewegbare Element stromaufwärts bewegt;
 eine Düse (8) mit einem Auslasskanal (10, 10a, 10b) und einer Auslassöffnung (12), die mit dem Auslasskanal (10, 10a, 10b) kommuniziert; und

ein drehbares Ventilelement (14), das zwischen einer ersten Position, in der die innere Fluidkammer (6) in Fluidkommunikation mit der Auslassöffnung (12) steht, wobei das flüssige Material von der inneren Fluidkammer (6) durch den Auslasskanal (10, 10a, 10b) und die Auslassöffnung (12) fließt, und einer zweiten Position drehbar ist, in der die innere Fluidkammer (6) nicht in Fluidkommunikation mit der Auslassöffnung (12) steht,
 wobei die Düse (8) eine Schlitzdüse ist, und das drehbare Ventilelement (14) ein zylindrischer Stab ist und mindestens einen schlitzförmigen Durchgang (16) aufweist, und
dadurch gekennzeichnet, dass fluides Material durch Bewegung des ersten bewegbaren Elements (4) von der ersten stromabwärtigen Position in die

- zweite stromaufwärtige Position innerhalb der inneren Fluidkammer (6) zumindest teilweise in eine stromaufwärtige Richtung bewegt wird und flüssiges Material, das sich in dem Auslasskanal (10, 10a, 10b) zwischen der Auslassöffnung (12) und dem drehbaren Ventilelement (14) befunden hat, vollständig in den schlitzförmigen Durchgang (16) des drehbaren Ventilelements (14) gesaugt wird.
2. Gerät (1) nach Anspruch 1, 5
dadurch gekennzeichnet, dass das drehbare Ventilelement (14) benachbart zu der Auslassöffnung (12) und/oder in einer stromabwärtigen Richtung relativ zu dem ersten bewegbaren Element (4) angeordnet ist. 10
 3. Gerät (1) nach einem der vorstehenden Ansprüche, 5
dadurch gekennzeichnet, dass der Auslasskanal (10, 10a) zumindest teilweise zwischen der Auslassöffnung (12) und dem drehbaren Ventilelement (14) angeordnet ist. 10
 4. Gerät (1) nach Anspruch 1, 10
dadurch gekennzeichnet, dass das erste bewegbare Element (4) innerhalb eines Seitenkanals bewegbar ist, der mit der inneren Fluidkammer (6) in Verbindung steht, vorzugsweise mit einem Verteilungskanal zum Verteilen von Fluid in den Auslassschlitz (10, 10a, 10b). 15
 5. Gerät (1) nach einem der vorstehenden Ansprüche, 20
dadurch gekennzeichnet, dass ein erstes pneumatisch und/oder elektrisch und/oder hydraulisch betätigtes Antriebsgerät (18) mit dem ersten bewegbaren Element (4) gekoppelt ist, um das erste bewegbare Element (4) vor und zurück zu bewegen. 25
 6. Gerät (1) nach einem der vorstehenden Ansprüche, 30
dadurch gekennzeichnet, dass ein zweites Antriebsgerät (20) mit dem drehbaren Ventilelement (14) gekoppelt ist, wobei das zweite Antriebsgerät (20) vorzugsweise ein rotierender pneumatischer, hydraulischer und/oder elektrischer Antrieb oder ein pneumatischer, hydraulischer und/oder elektrischer Linearantrieb ist. 35
 7. Gerät (1) nach einem der vorstehenden Ansprüche, 40
gekennzeichnet durch Einstellmittel (22a, 22b), die geeignet sind, die wirksame Länge und/oder die wirksame Breite und/oder die wirksame Form der Auslassöffnung (12) einzustellen. 45
 8. Gerät (1) nach einem der vorstehenden Ansprüche, 50
gekennzeichnet durch einen Volumenkompensationskanal (24) und ein bewegbares Verdrängungselement, das zumindest teilweise innerhalb des Volumenkompensationskanals (24) bewegbar ist, wobei das Volumen des Volumenkompensationskanals (24) durch die Bewegung des Verdrängungselements anpassbar ist. 55
 9. Gerät (1) nach einem der vorstehenden Ansprüche, 5
dadurch gekennzeichnet, dass das Gehäuse (2) mindestens einen ersten Teil (2a) und einen zweiten Teil (2b) umfasst, wobei der erste Teil (2a) und der zweite Teil (2b) lösbar miteinander oder mit einem Adapterelement gekoppelt sind. 10
 10. Gerät (1) nach Anspruch 9, 10
dadurch gekennzeichnet, dass das erste bewegbare Element (4) in dem zweiten Teil (2b) angeordnet ist und/oder 15
das drehbare Ventilelement (14) teilweise in dem ersten Teil (2a) und teilweise in dem zweiten Teil (2b) angeordnet ist und/oder 20
die innere Fluidkammer (6) teilweise in dem ersten Teil (2a) und teilweise in dem zweiten Teil (2b) angeordnet ist und/oder 25
der Volumenkompensationskanal (24) teilweise in dem ersten Teil (2a) und teilweise in dem zweiten Teil (2b) angeordnet ist und/oder 30
die Schlitzdüse (8) zwischen dem ersten Teil (2a) und dem zweiten Teil (2b) angeordnet ist. 35
 11. Verfahren (100) zum intermittierenden Auftragen eines flüssigen Materials, insbesondere eines geschäumten Klebstoffs, auf ein Substrat unter Verwendung des Abgabegeräts (1) nach mindestens einem der Ansprüche 1-10, umfassend die Schritte: 40

Treiben (102) des flüssigen Materials aus der inneren Fluidkammer (6) durch den Auslasskanal (10, 10a, 10b) und die Auslassöffnung (12); Erhöhen des Volumens (104) der inneren Fluidkammer (6) um ein vorbestimmtes Volumen; und 45
Unterbrechen (106) der Fluidkommunikation zwischen der inneren Fluidkammer (6) und der Auslassöffnung (12), nachdem das Volumen der inneren Fluidkammer (6) um das vorbestimmte Volumen (104) durch Drehen des drehbaren Ventilelements (14) von einer ersten Position in eine zweite Position (107) vergrößert wurde, wobei das Ventilelement (14) ein zylindrischer Stab mit mindestens einem schlitzförmigen Durchgang (16) aufweist. 50
 12. Verfahren (100) nach Anspruch 11, 50
die die Schritte umfassen: 55

Verringern des Volumens (108) der inneren Fluidkammer (6) um das vorbestimmte Volumen; und 60
Wiederherstellen der Fluidkommunikation (110) zwischen der inneren Fluidkammer (6) und der Auslassöffnung (12). 65

13. Verfahren (100) nach Anspruch 11 oder 12,
dadurch gekennzeichnet, dass das vorbestimmte Volumen einem Volumen des Auslasskanals (10, 10a, 10b) zwischen der Auslassöffnung (12) und dem drehbaren Ventilelement (14) entspricht. 5
14. Verfahren (100) nach einem der Ansprüche 11 bis 13,
dadurch gekennzeichnet, dass die Erhöhung des Volumens (104) der inneren Fluidkammer (6) um ein vorbestimmtes Volumen umfasst:
Bewegen eines ersten bewegbaren Elements (4), das zumindest teilweise innerhalb der inneren Fluidkammer (6) angeordnet ist, von einer ersten stromabwärtigen Position in eine zweite stromaufwärtige Position (105a) und/oder Bewegen des ersten bewegbaren Elements (4) zumindest teilweise aus der inneren Fluidkammer (105b) heraus. 10 15
15. Verfahren (100) nach einem der Ansprüche 11 bis 14,
die den Schritt umfassen:
Einstellen (112) der effektiven Länge und/oder der effektiven Breite und/oder der effektiven Größe der Auslassöffnung (12). 20 25
16. Verfahren (100) nach einem der Ansprüche 11 bis 15,
die den Schritt umfassen:
Auftragen von Klebstoff auf einen Buchrücken. 30

Revendications

1. Dispositif (1) pour appliquer de façon intermittente un matériau liquide, en particulier un adhésif en mousse, sur un substrat, comprenant : 35
- un boîtier (2) ayant une chambre de fluide interne (6) ; 40
- un premier organe mobile (4) au moins partiellement mobile à l'intérieur de ladite chambre de fluide interne (6) entre une première position en aval et une seconde position en amont, de telle sorte qu'un fluide à l'intérieur de ladite chambre de fluide interne soit au moins partiellement déplacé dans une direction en amont lorsque ledit organe mobile se déplace en amont ; 45
- une buse (8) ayant un canal d'évacuation (10, 10a, 10b) et une ouverture d'évacuation (12) communiquant avec ledit canal d'évacuation (10, 10a, 10b) ; et 50
- un organe vanne rotatif (14) rotatif entre une première position, dans laquelle ladite chambre de fluide interne (6) est en communication fluïdique avec ladite ouverture d'évacuation (12), dans lequel le matériau liquide s'écoule à partir de ladite chambre de fluide interne (6) à travers ledit canal 55

d'évacuation (10, 10a, 10b) et ladite ouverture d'évacuation (12), et une seconde position, dans laquelle ladite chambre de fluide interne (6) n'est pas en communication fluïdique avec ladite ouverture d'évacuation (12), dans lequel la buse (8) est une buse en fente, et ledit organe vanne rotatif (14) est une tige cylindrique et a au moins une voie de passage en forme de fente (16), et **caractérisé en ce que**, par l'intermédiaire du mouvement du premier organe mobile (4) de la première position en aval à la seconde position en amont, un matériau fluïde à l'intérieur de la chambre de fluide interne (6) est au moins partiellement déplacé dans une direction en amont et un matériau liquide, qui a été dans le canal d'évacuation (10, 10a, 10b) entre l'ouverture d'évacuation (12) et l'organe vanne rotatif (14), est entièrement aspiré dans la voie de passage en forme de fente (16) de l'organe vanne rotatif (14).

2. Dispositif (1) selon la revendication 1, **caractérisé en ce que** ledit organe vanne rotatif (14) est disposé de façon adjacente à ladite ouverture d'évacuation (12) et/ou disposé dans une direction en aval relativement audit premier organe mobile (4).
3. Dispositif (1) selon l'une des revendications précédentes, **caractérisé en ce que** ledit canal d'évacuation (10, 10a) est au moins partiellement disposé entre ladite ouverture d'évacuation (12) et ledit organe vanne rotatif (14).
4. Dispositif selon la revendication 1, **caractérisé en ce que** ledit premier organe mobile (4) est mobile à l'intérieur d'un canal latéral communiquant avec ladite chambre de fluide interne (6), de préférence avec un canal de distribution pour distribuer un fluïde dans ladite fente d'évacuation (10, 10a, 10b).
5. Dispositif (1) selon l'une des revendications précédentes, **caractérisé en ce qu'**un premier dispositif d'entraînement pneumatiquement et/ou électriquement et/ou hydrauliquement actionné (18) est couplé audit premier organe mobile (4) pour déplacer ledit premier organe mobile (4) en va-et-vient.
6. Dispositif (1) selon l'une des revendications précédentes, **caractérisé en ce qu'**un second dispositif d'entraînement (20) est couplé audit organe vanne rotatif (14), ledit second dispositif d'entraînement (20) étant de préférence un entraînement pneumatique, hydraulique et/ou électrique rotatif ou un élément li-

- néaire pneumatique, hydraulique et/ou électrique.
7. Dispositif (1) selon l'une des revendications précédentes,
caractérisé par des moyens d'ajustement (22a, 22b) adaptés pour ajuster la longueur effective et/ou la largeur effective et/ou la forme effective de ladite ouverture d'évacuation (12). 5
8. Dispositif (1) selon l'une des revendications précédentes,
caractérisé par un canal de compensation de volume (24) et un élément de déplacement mobile au moins partiellement mobile à l'intérieur dudit canal de compensation de volume (24), dans lequel le volume dudit canal de compensation de volume (24) est adaptable par le mouvement dudit élément de déplacement. 10
9. Dispositif (1) selon l'une des revendications précédentes,
caractérisé en ce que ledit boîtier (2) comprend au moins une première partie (2a) et une seconde partie (2b), dans lequel ladite première partie (2a) et ladite seconde partie (2b) sont couplées l'une à l'autre de façon détachable ou à un élément adaptateur. 15
10. Dispositif (1) selon la revendication 9,
caractérisé en ce que ledit premier organe mobile (4) est disposé dans ladite seconde partie (2b) et/ou ledit organe vanne rotatif (14) est disposé partiellement dans ladite première partie (2a) et partiellement dans ladite seconde partie (2b),
 et/ou ladite chambre de fluide interne (6) est disposée partiellement dans ladite première partie (2a) et partiellement dans ladite seconde partie (2b),
 et/ou ledit canal de compensation de volume (24) est disposé partiellement dans ladite première partie (2a) et partiellement dans ladite seconde partie (2b) et/ou ladite buse en fente (8) est disposée entre ladite première partie (2a) et ladite seconde partie (2b). 20
11. Procédé (100) pour appliquer de façon intermittente un matériau liquide, en particulier un adhésif en mousse, sur un substrat, en utilisant le dispositif de distribution (1) selon au moins une des revendications 1 à 10, comprenant les étapes suivantes : 25
- la contrainte (102) du matériau liquide de s'écouler à partir de ladite chambre de fluide interne (6) à travers ledit canal d'évacuation (10, 10a, 10b) et ladite ouverture d'évacuation (12) ; l'augmentation du volume (104) de ladite chambre de fluide interne (6) selon un volume prédéterminé ; et 50
- l'interruption (106) de la communication fluide entre ladite chambre de fluide interne (6) et ladite ouverture d'évacuation (12) après que le 55
- volume de ladite chambre de fluide interne (6) est augmenté selon le volume prédéterminé (104) en mettant en rotation l'organe vanne rotatif (14) comprenant une tige cylindrique avec au moins une voie de passage en forme de fente (16) depuis une première position dans une seconde position (107).
12. Procédé (100) selon la revendication 11, comprenant les étapes suivantes :
 la réduction du volume (108) de ladite chambre de fluide interne (6) selon ledit volume prédéterminé ; et
 le ré-établissement de la communication fluide (110) entre ladite chambre de fluide interne (6) et ladite ouverture d'évacuation (12).
13. Procédé (100) selon la revendication 11 ou 12,
caractérisé en ce que ledit volume prédéterminé est égal à un volume dudit canal d'évacuation (10, 10a, 10b) entre ladite ouverture d'évacuation (12) et ledit organe vanne rotatif (14).
14. Procédé (100) selon l'une des revendications 11 à 13,
caractérisé en ce que l'augmentation du volume (104) de ladite chambre de fluide interne (6) selon un volume prédéterminé comprend :
 le déplacement du premier organe mobile (4) qui est disposé au moins partiellement à l'intérieur de ladite chambre de fluide interne (6) depuis une première position en aval dans une seconde position en amont (105a) et/ou le déplacement dudit premier organe mobile (4) au moins partiellement hors de ladite chambre de fluide interne (105b).
15. Procédé (100) selon l'une des revendications 11 à 14, comprenant l'étape suivante :
 l'ajustement (112) de la longueur effective et/ou de la largeur effective et/ou de la taille effective de ladite ouverture d'évacuation (12).
16. Procédé (100) selon l'une des revendications 11 à 15, comprenant l'étape suivante :
 l'application d'adhésif sur un dos d'un livre.

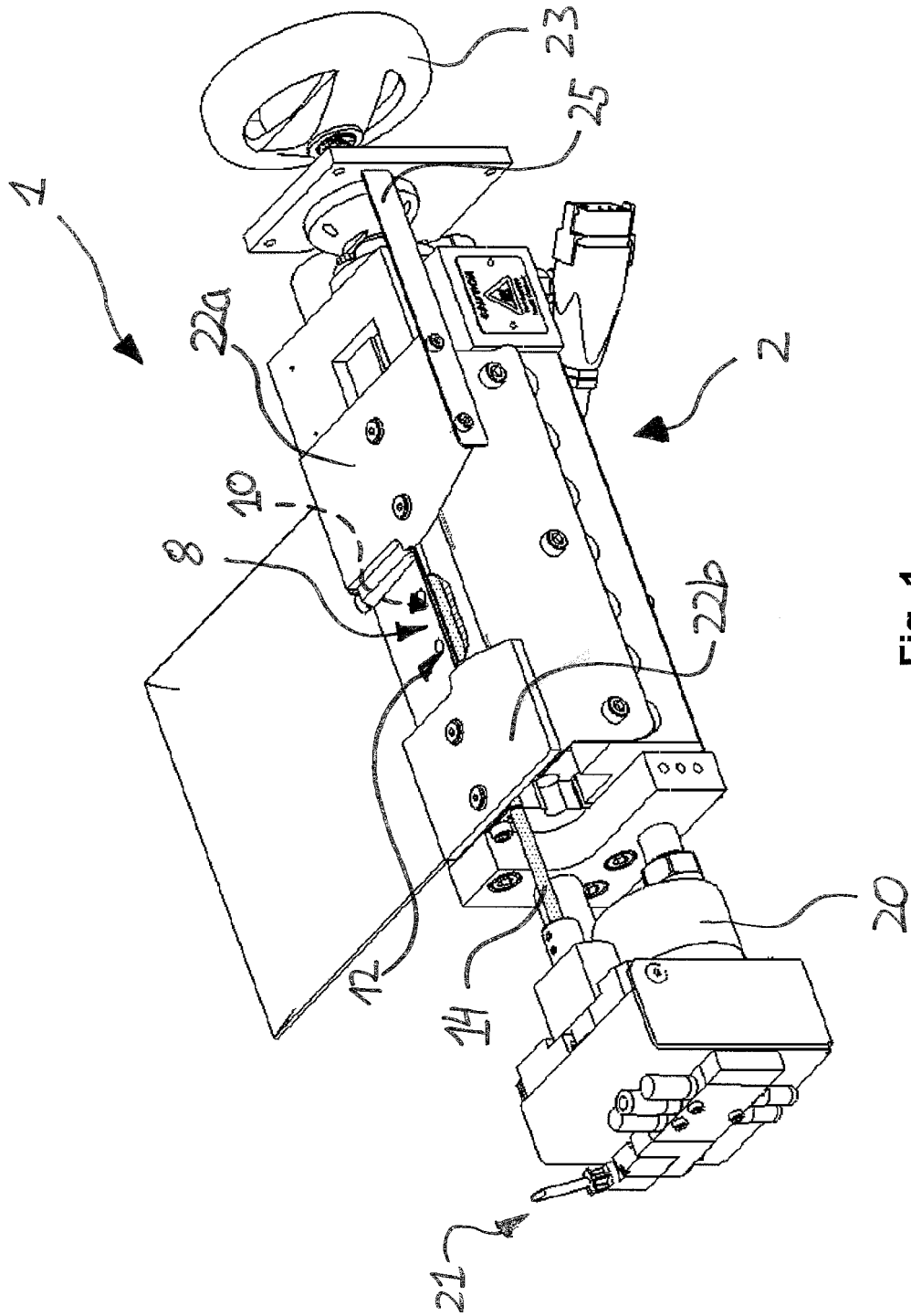

Fig. 1

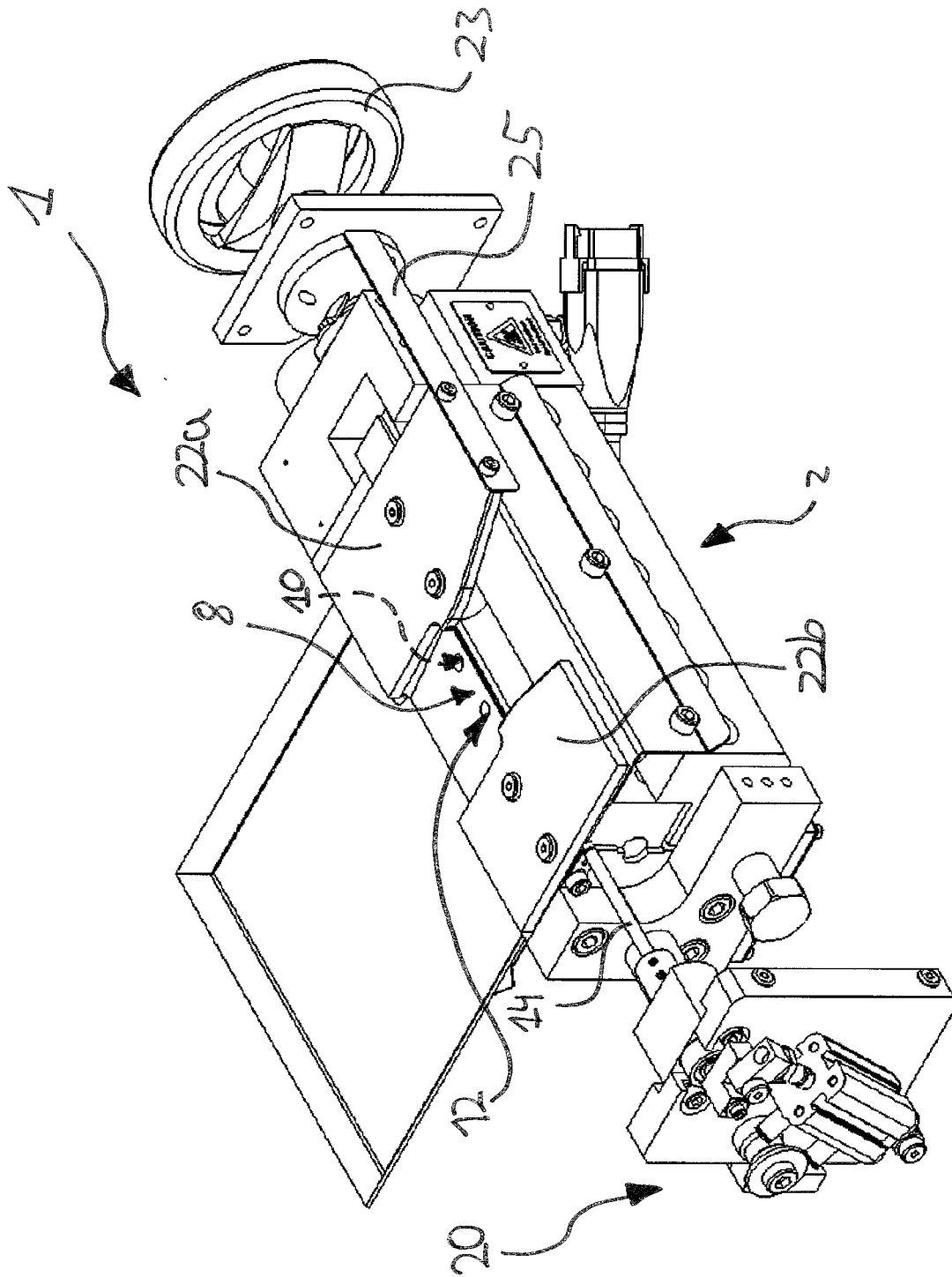

Fig. 2

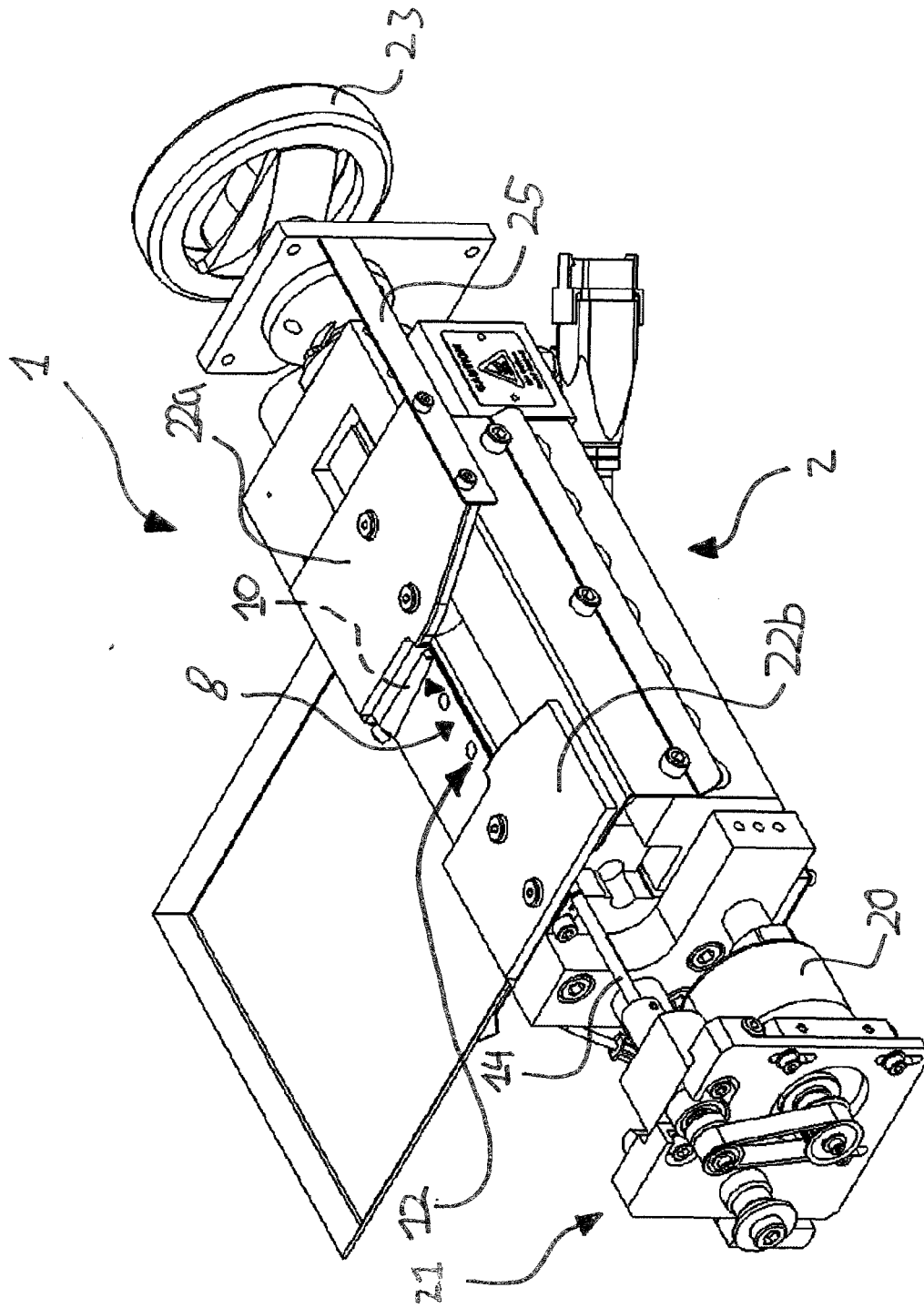

Fig. 3

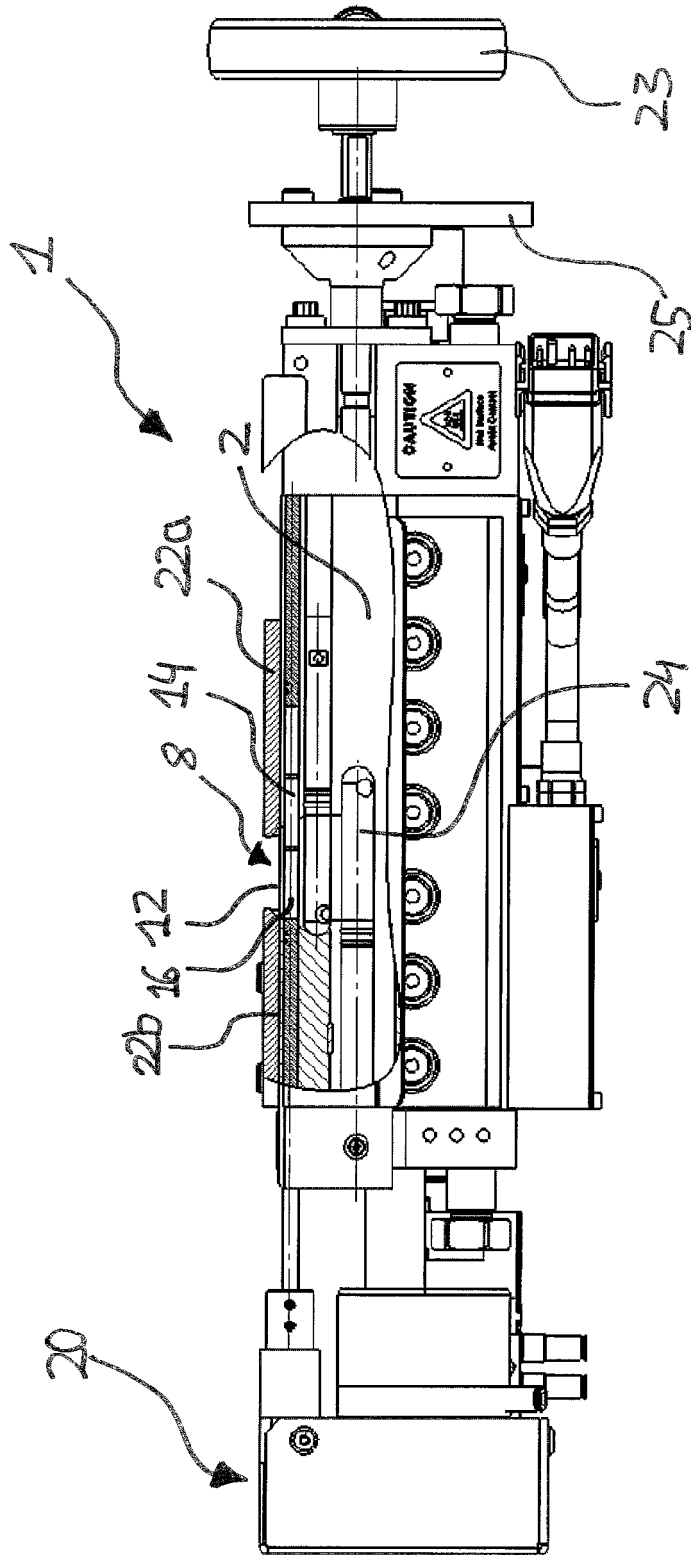

Fig. 4

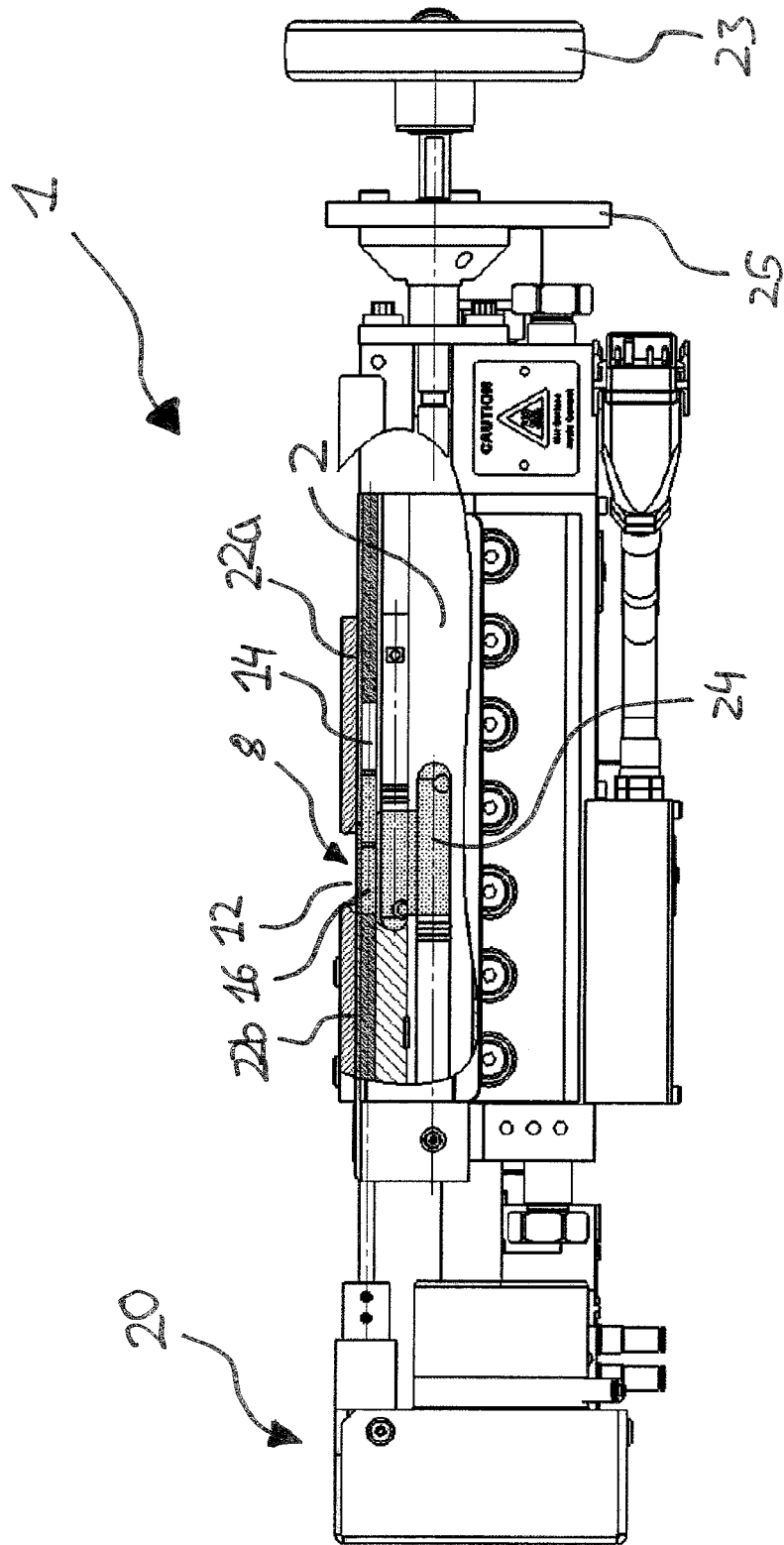

Fig. 5

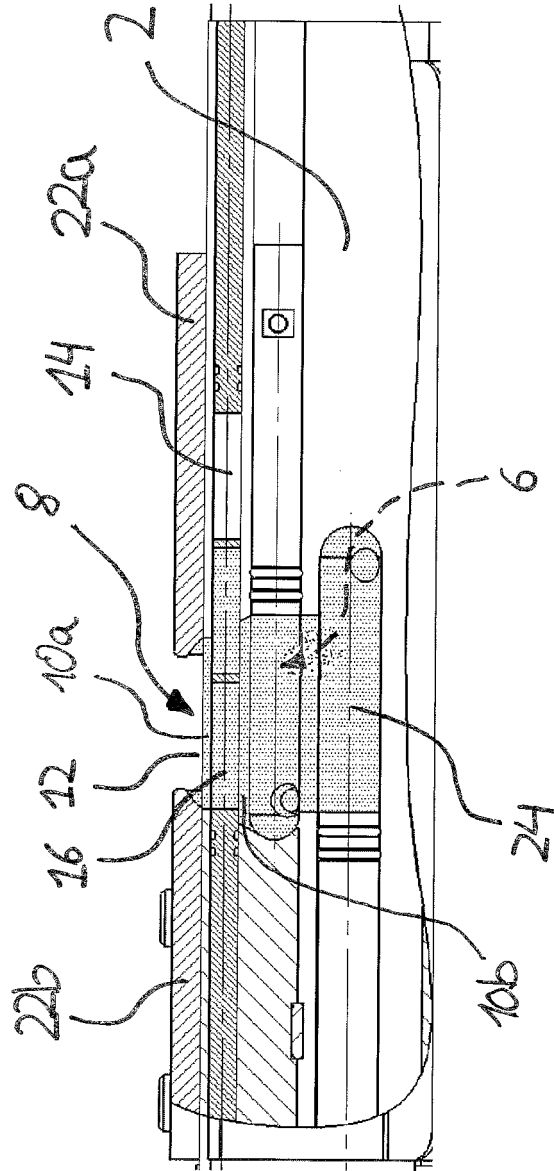

Fig. 6

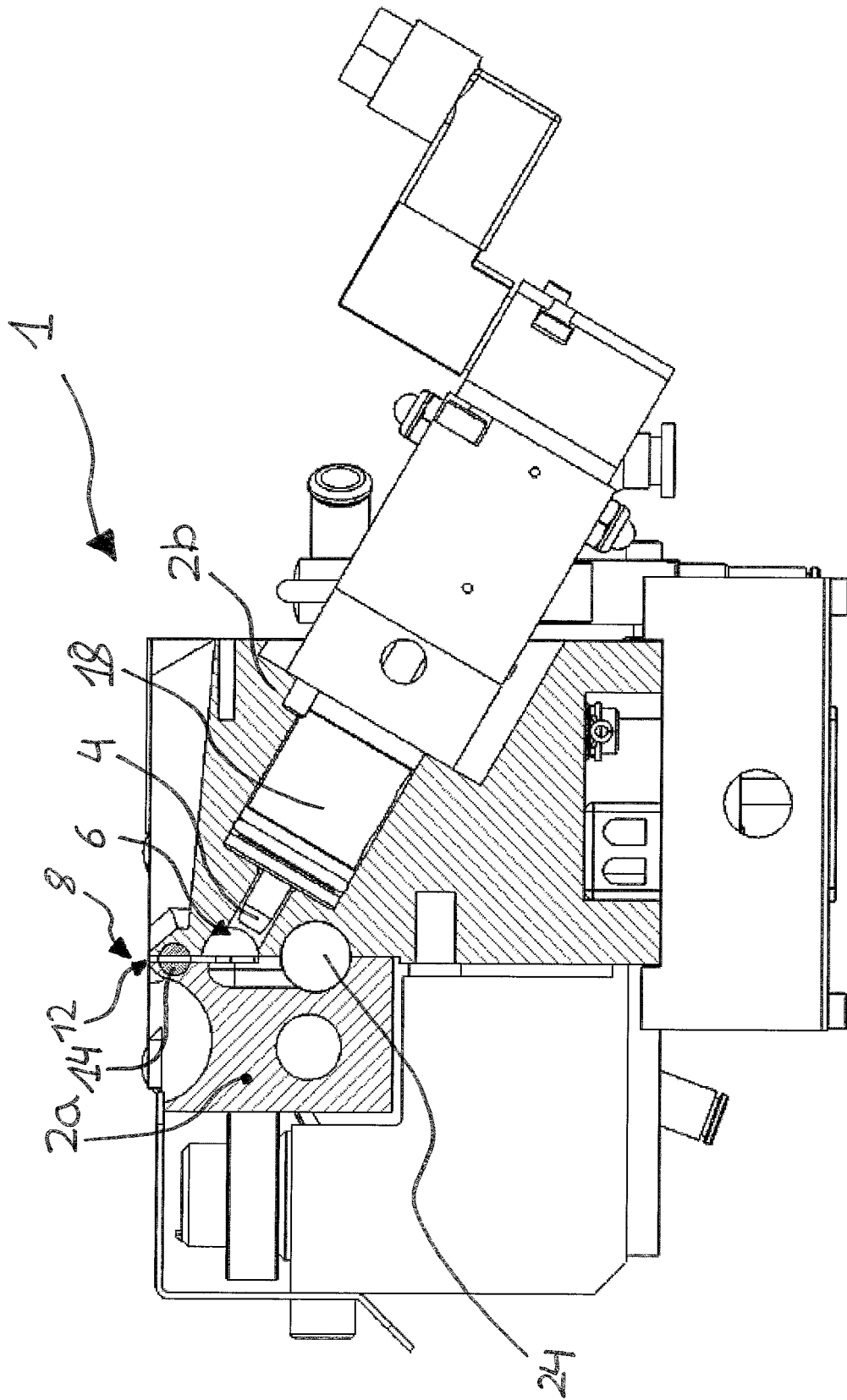

Fig. 7

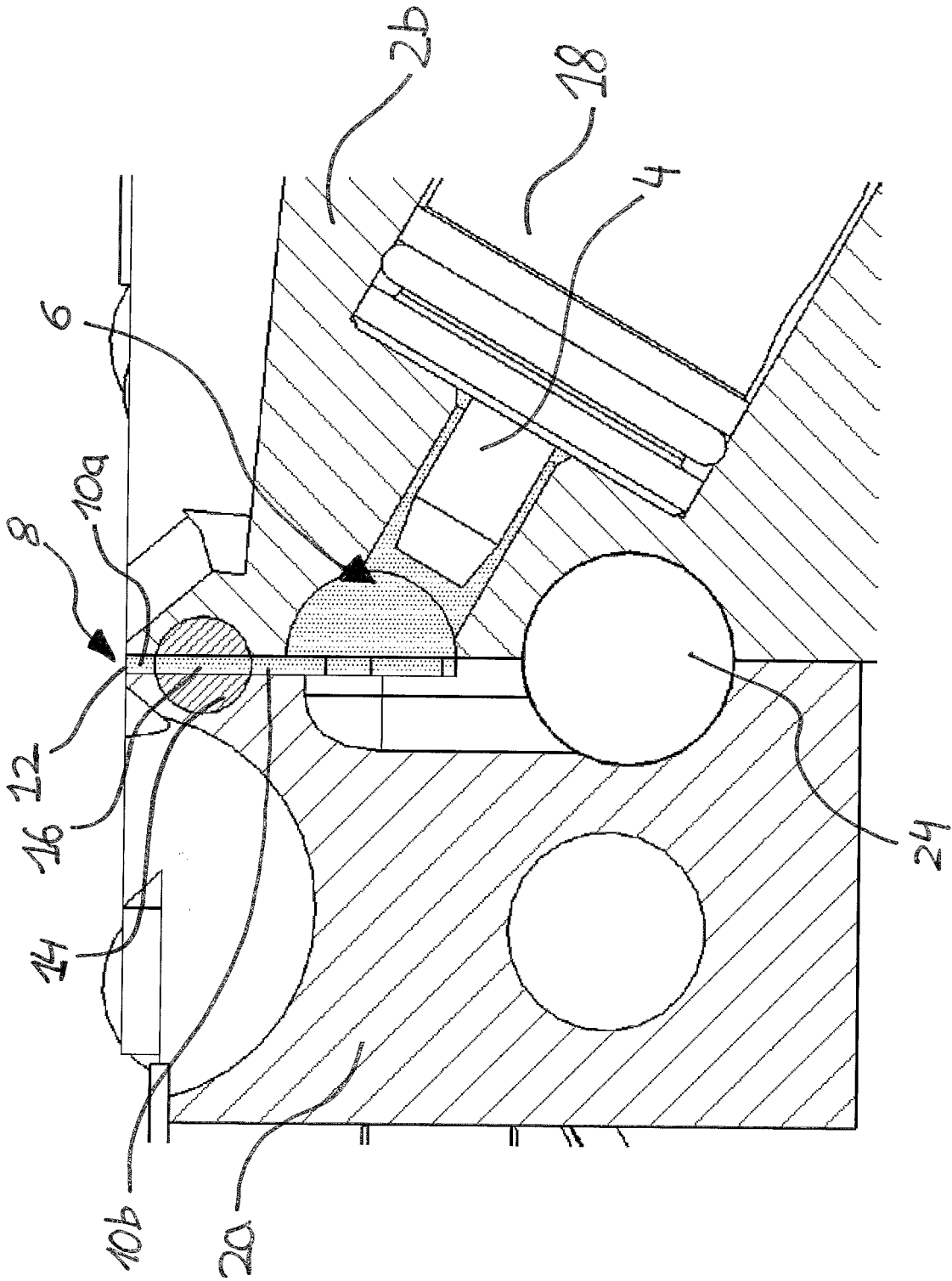

Fig. 8

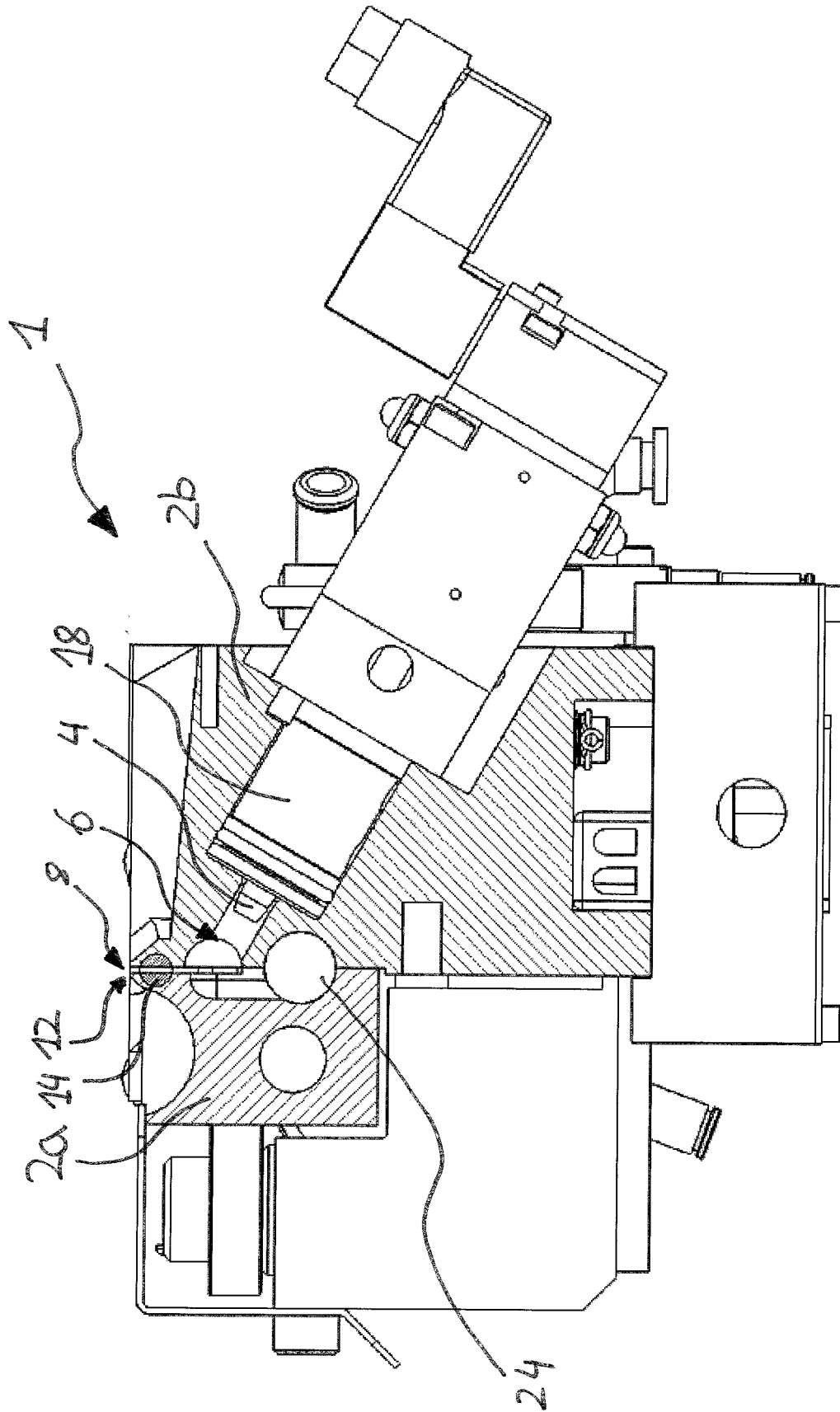

Fig. 9

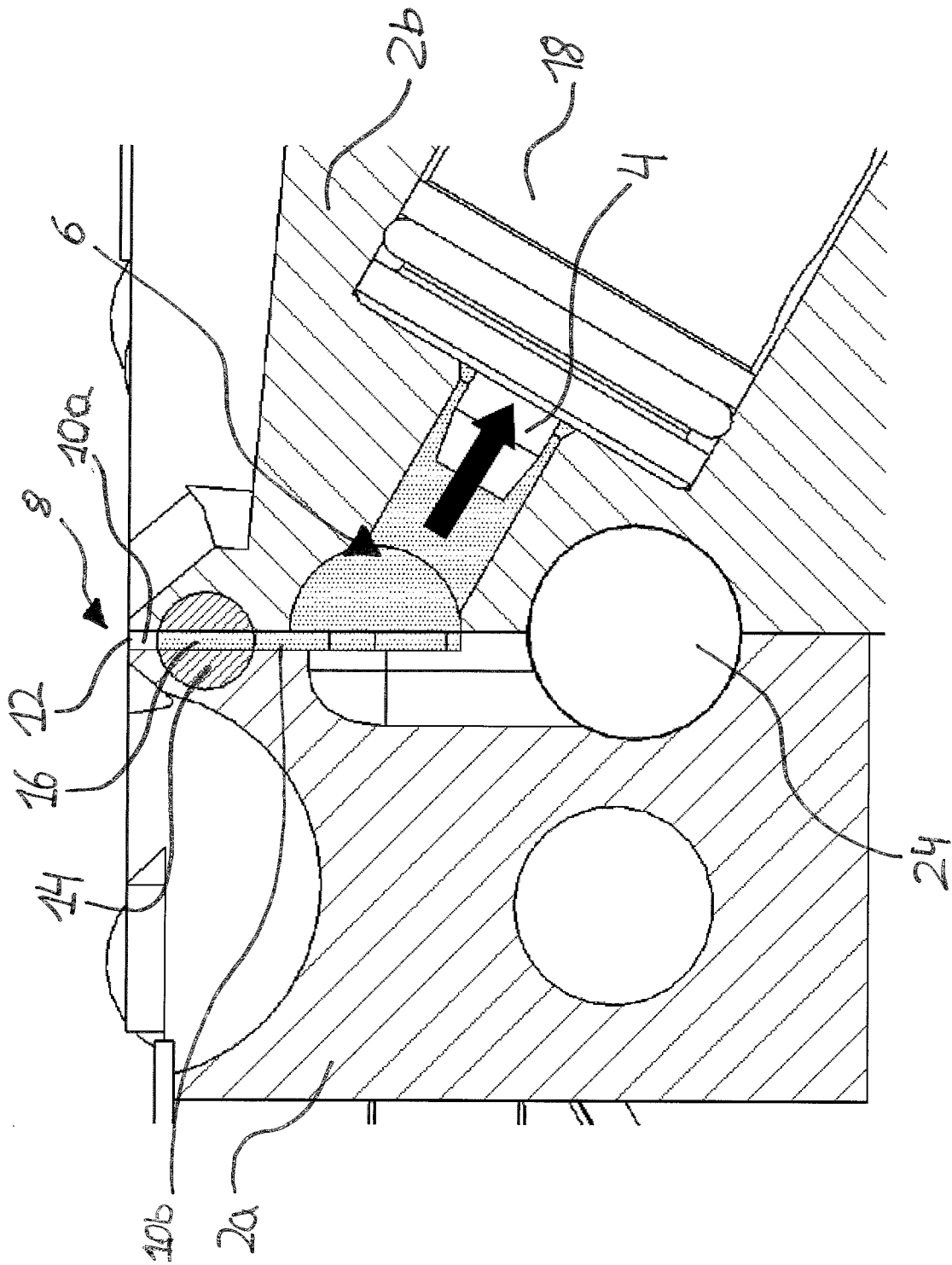

Fig. 10

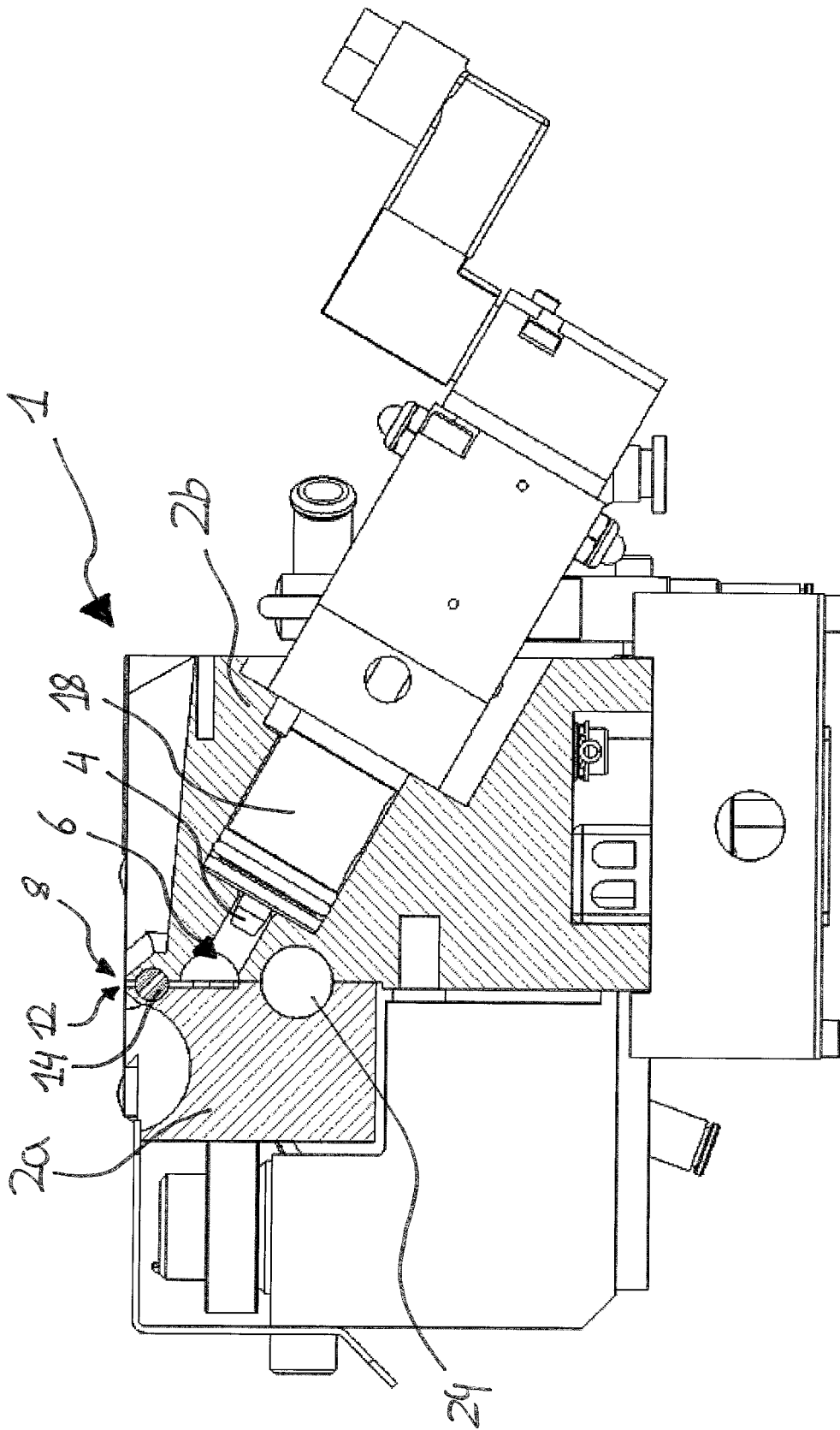

Fig. 11

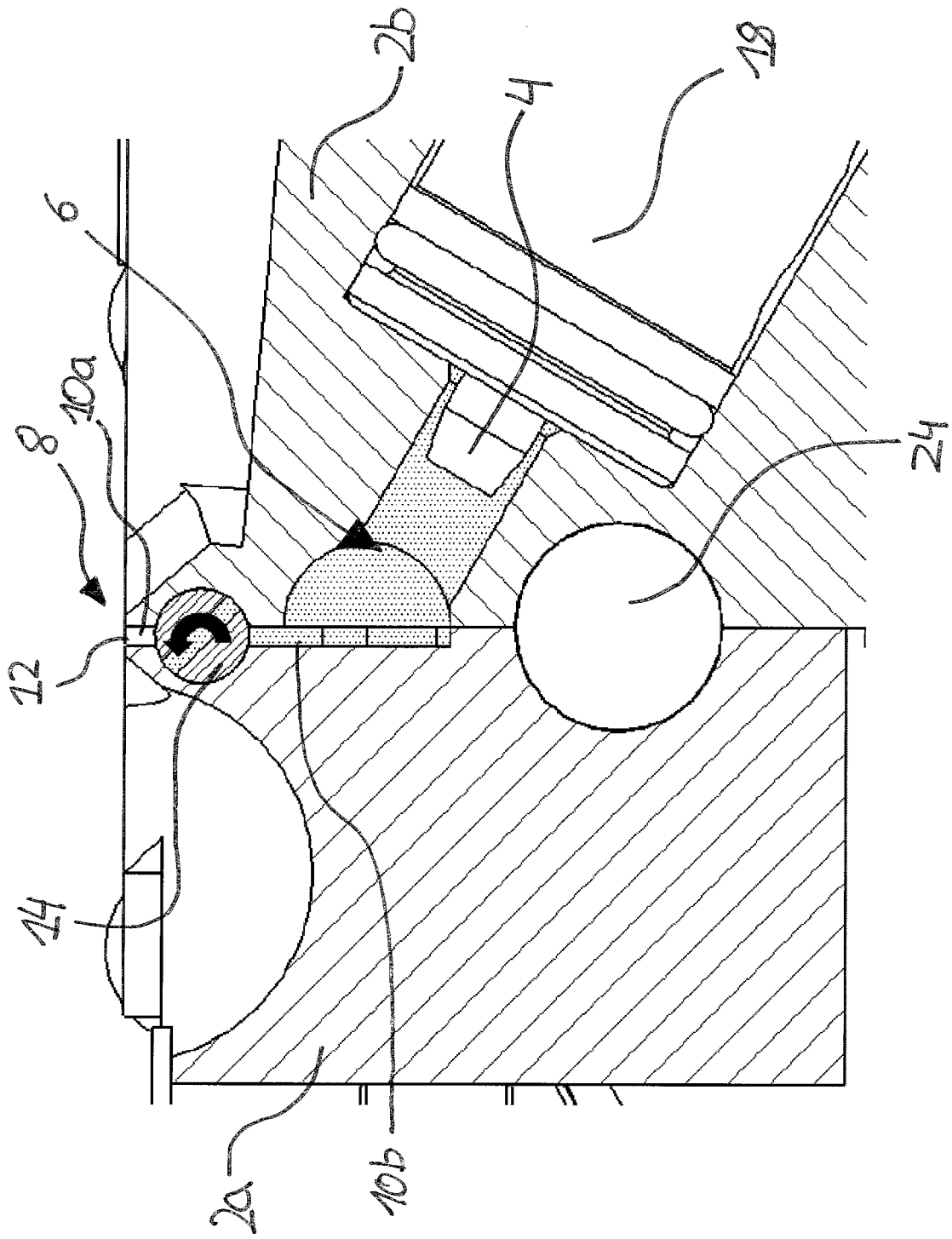

Fig. 12

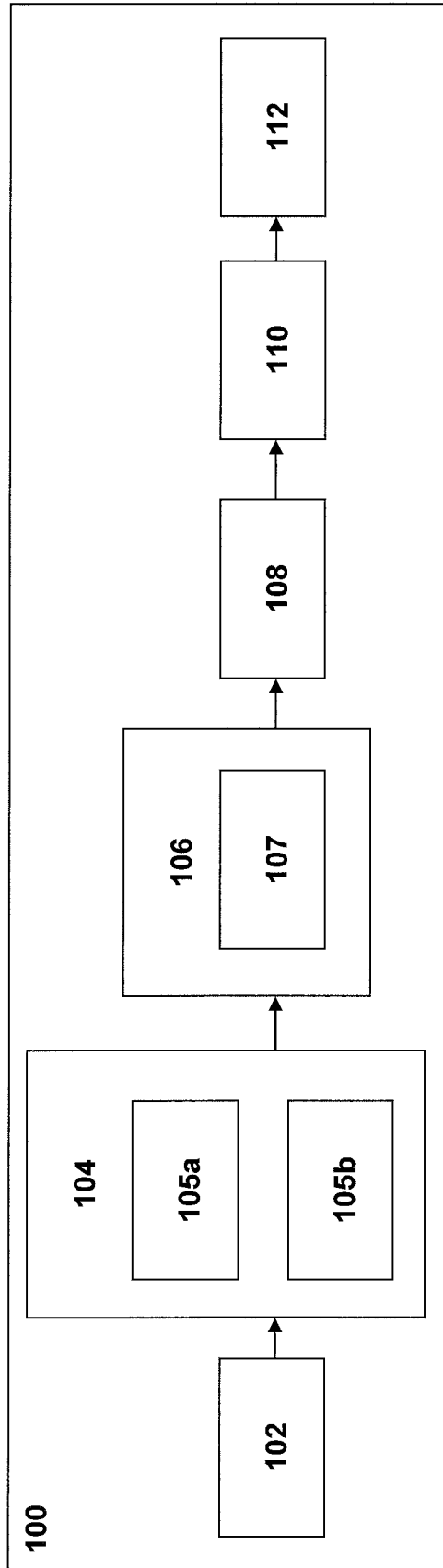

Fig. 13

REFERENCES CITED IN THE DESCRIPTION

This list of references cited by the applicant is for the reader's convenience only. It does not form part of the European patent document. Even though great care has been taken in compiling the references, errors or omissions cannot be excluded and the EPO disclaims all liability in this regard.

Patent documents cited in the description

- EP 1419900 B1 [0008]
- JP 2007253013 A [0009]
- US 2013277457 A [0009]
- EP 2319707 A1 [0009]
- US 2002053406 A1 [0009]
- US 20080166207 A1 [0009]
- US 20040062866 A1 [0009]