

(19)



(11)

**EP 3 730 716 B1**

(12)

**EUROPEAN PATENT SPECIFICATION**

(45) Date of publication and mention of the grant of the patent:  
**11.08.2021 Bulletin 2021/32**

(51) Int Cl.:  
**E04D 13/035 (2006.01)**

(21) Application number: **20180346.7**

(22) Date of filing: **29.04.2019**

**(54) ROOF WINDOW WITH IMPROVED COVERING ARRANGEMENT AND METHOD OF PROVIDING A ROOF WINDOW WITH IMPROVED COVERING ARRANGEMENT**

DACHFENSTER MIT VERBESSERTER ABDECKUNGSANORDNUNG UND VERFAHREN ZUR BEREITSTELLUNG EINES DACHFENSTERS MIT VERBESSERTER ABDECKUNGSANORDNUNG  
 FENÊTRE DE TOIT AVEC AGENCEMENT DE RECOUVREMENT AMÉLIORÉ ET PROCÉDÉ DE FOURNITURE D'UNE FENÊTRE DE TOIT AVEC AGENCEMENT DE RECOUVREMENT AMÉLIORÉ

(84) Designated Contracting States:  
**AL AT BE BG CH CY CZ DE DK EE ES FI FR GB GR HR HU IE IS IT LI LT LU LV MC MK MT NL NO PL PT RO RS SE SI SK SM TR**

(30) Priority: **30.04.2018 DK PA201870257**

(43) Date of publication of application:  
**28.10.2020 Bulletin 2020/44**

(62) Document number(s) of the earlier application(s) in accordance with Art. 76 EPC:  
**19171528.3 / 3 564 461**

(73) Proprietor: **VKR Holding A/S**  
**2970 Hørsholm (DK)**

(72) Inventor: **Grinvalds, Carsten**  
**2970 Hørsholm (DK)**

(74) Representative: **AWA Denmark A/S**  
**Strandgade 56**  
**1401 Copenhagen K (DK)**

(56) References cited:  
**EP-A1- 0 352 206 WO-A1-2018/077367**  
**DE-A1- 2 628 691 DE-U1-202014 005 241**  
**GB-A- 1 473 570 US-A1- 2016 052 202**

- **CHRISTIAN HOPMANN ET AL: "Joining of Metal-Plastics-Hybrid Structures Using Laser Radiation by Considering the Surface Structure of the Metal", JOURNAL OF POLYMERS, vol. 2016, 19 July 2016 (2016-07-19), pages 1-10, XP055436593, ISSN: 2356-7570, DOI: 10.1155/2016/4734913**

**EP 3 730 716 B1**

Note: Within nine months of the publication of the mention of the grant of the European patent in the European Patent Bulletin, any person may give notice to the European Patent Office of opposition to that patent, in accordance with the Implementing Regulations. Notice of opposition shall not be deemed to have been filed until the opposition fee has been paid. (Art. 99(1) European Patent Convention).

## Description

### Technical Field

[0001] The present invention relates to a roof window, particularly for installation in an inclined roof surface, comprising a frame, a sash configured to be moved between a closed position and an open position, in which the sash assumes an angle relative to the frame, a set of hinges, and a covering arrangement including a frame side covering element having a top portion and an end edge, and a sash side covering element having a top portion and an end edge facing the end edge of the frame side covering element to form a gap, said covering arrangement being configured to cover at least said hinge in the closed position of the sash. The invention furthermore relates to a method of providing a roof window with improved covering arrangement.

### Background Art

[0002] Basically, roof windows may be provided in a number of varieties and include more or less complicated structures in order to allow opening of the sash and to fulfil other functions, such as ventilation, while permitting cleaning of the outside of the pane from inside the building. The varieties include roof windows of the pivoting type, the hinge axis being either located at the centre or displaced from the centre of the window, and top-hung roof windows that pivot for cleaning by means of an intermediate frame. Such hinged roof windows are known for instance from GB1473570 A, DE2628691 A1 and EP0352206 A1.

[0003] These requirements are made possible by the provision of a hinge with a particular pattern of movements, which in turn makes it possible to establish an overlap between the covering element fastened to the frame and the counterpart covering element fastened to the sash in the closed position of the roof window. In such a hinge, the covering elements thus generally comprise at least two parts, one for covering the sash hinge part and one covering the frame hinge part. The covering elements are designed to protect the hinge and interior parts of the window from amongst other things weather, dirt and grime, since this may cause the hinge to rust and in worst case cause the window to leak rain water and thereby possibly cause damage. The two covering elements are designed to allow an angular motion relative to each other, while opening and closing the window. The covering elements are typically made of metal which is well-known to possess excellent strength and wearability properties. In order to improve the weather-tightness of the covering assembly, Applicant's European patent No. EP 1 070 179 B1 describes how a joggled connection member on the sash cover element is inserted under the end of the frame cover element to provide a pressure relief chamber to prevent water penetration. While this solution has proven to function well, it can be difficult to

control the exact configuration of the elements of the covering assembly in the mounted condition on the roof window, due to the unavoidable manufacturing tolerances.

### 5 Summary of Invention

[0004] It is therefore the object of the invention to provide a roof window, in which the weather-proofing of the covering arrangement is improved and made more consistent.

10 [0005] In a first aspect, this is achieved with a roof window according to claim 1.

[0006] By providing one or more separate transition elements at or near gap between the frame and sash covering elements, the invention is based on the recognition that it will be more or less impossible to eliminate the gap between the respective end edges of the frame and sash side covering elements in the closed position of the sash, due to the presence of manufacturing tolerances and provides an alternative means of preventing water and other precipitation from entering below the frame and sash side covering elements. Without wishing to be bound by theory, it is believed that influencing the flow conditions at or near the gap, in the closed position of the sash, provides for sufficient influence on the flow of wind-impacted precipitation to form an outgoing stream of air to counteract penetration of water through the gap.

20 [0007] In a presently preferred embodiment, the at least one transition element includes a first transition element connected to the sash side covering element and having a first venturi portion configured to face an interior side of the top portion of the frame side covering element in the closed position of the sash to provide a constricted section between an inner channel section and an outer channel section, nearest said cap. In such a constricted section, the venturi effect will occasion a reduction in the pressure and an ensuing increase of the velocity of the air stream. Expressed in another way, this will have the effect of drawing any precipitation in the form of rain, snow etc. in the direction towards the outdoor, i.e. the external side of the side covering elements. In a further development of this preferred embodiment, a second transition element is connected to the frame side covering element and comprising a flat portion and a second venturi portion to be located opposite the first venturi portion in the constricted section between the inner channel section and the outer channel section in the closed position of the sash. This will enhance the venturi effect even further.

30 [0008] In another presently preferred embodiment, the first transition element comprises a breaker portion configured to be located in the gap between the respective end edges of the frame side covering element and the sash side covering element in the closed position of the sash. Again, without wishing to be bound by theory, it is believed that the upstanding breaker portion will enhance the flow conditions even further to prevent in-flow of water

under the covering arrangement.

**[0009]** In a second aspect, a method of providing a roof window with improved covering arrangement according to claim 3 is devised.

**[0010]** Other presently preferred embodiments and further advantages will be apparent from the subsequent detailed description and drawings.

### Brief Description of Drawings

**[0011]** In the following description embodiments of the invention will be described with reference to the schematic drawings, in which

Fig. 1 is a perspective view of a roof window, seen from the interior side and in an open position, including a prior art covering arrangement;

Fig. 2 is a perspective view, on a larger scale, of a prior art covering arrangement;

Fig. 3 is a partial perspective view of an embodiment of the covering arrangement of a roof window according to the invention;

Figs 4 and 5 are partial perspective views, seen from different angles, of an embodiment of the covering arrangement of the roof window according to the invention;

Figs 6 and 7 are partial perspective views, seen from different angles, of a first transition element of the covering arrangement in an embodiment of the roof window according to the invention;

Fig. 8 is a partial perspective view of a second transition element of the covering arrangement in an embodiment of the roof window according to the invention;

Fig. 9 is a plan view of the second transition element of Fig. 8;

Fig. 10 is a partial perspective sectional view of the covering arrangement of Figs 6 to 9; and

Fig. 11 is a partial sectional view of the covering arrangement of Fig. 10.

### Description of Embodiments

**[0012]** In a manner known per se, the window comprises a sash 2 carrying a glazing in the form of a pane 3 and a frame 1. The window is intended to be built into a surface, which is inclined with respect to the horizontal, typically a roof, and the window will in the following be referred to as roof window. At a position between the top and centre of the window, there is a hinge connection between the frame 1 and the sash 2. The hinge connection in Fig. 1 comprises a set of hinges, of which one hinge 10' is visible. The same operation as described above and from here on is also true for the type of hinge described in the Applicant's pending Danish patent application No. PA 2015 70717 filed on 06 November 2015. Other hinges that include pivot hinges are for instance disclosed in Applicant's EP 1 038 083 B1 and EP 1 781

883 B1, which are very versatile as regards operational areas and adaptation of components. Examples of roof windows incorporating such adapted hinges are shown in Applicant's published European patent applications EP 2 770 146 A1 and EP 2 770 149 A1. From a closed position, the user operates the operating device of the window. The operating device typically comprises a handle (not shown) connected with the sash bottom member and/or an operating and locking assembly including a ventilation flap at the sash top member with a lock mechanism to interact with a striking plate on the frame top member. As will be described in further detail below, the hinge 10 exerts a moment on the sash 2, and in combination with the force, and hence moment, exerted by the user operating the operating device, the moment resulting from the weight of the sash 2 and pane 3 is overcome, along with any frictional forces present. All in all, the opening operation entails that the sash 2 is moved from a closed position to an open position as represented by Fig. 1, in which the sash plane forms an opening angle with the frame plane. Closing the window from the open position entails the opposite movement of the sash 2. It is possible to position the sash 2 in a number of arbitrary opening positions, in which the sash 2 is held stable relative to the frame 1. The sash 2 is also able to be rotated substantially through 180° to allow cleaning of the outside of the pane 3 from the inside of the building in which the roof window is installed.

**[0013]** The frame 1 and sash 2 is each formed by four members of which one frame side member 1a and one sash side member 2a are indicated. The sash 2 is openable with respect to the frame 1, as the sash 2 may be moved from a closed position, in which e.g. the sash side member 2a is substantially parallel with the frame side member 1a, to an open position, in which the sash side member 2a forms an angle with the frame side member 1a. During this movement the sash 2 rotates about a hinge axis  $\alpha$  situated at the hinge connection. As indicated in Fig. 1, the hinge axis  $\alpha$  is located between a centre axis and the top of the roof window, preferably in the interval 1/3 to 2/3 of the distance between the centre axis and the top, most preferred substantially at 1/2 of the distance between the centre axis and the top. Other positions of the hinge axis are of course conceivable, for instance at the centre of the roof window.

**[0014]** When referring to the Figures, the terms up, down, upwards, downwards, top and bottom are taken relative to how the figures are displayed, that is having the frame arranged in a lying position with the covering elements facing upwards. A front view is taken from the hinge and viewing towards the frame. A view from behind is therefore taken as viewed from the frame towards the hinge. A direction longitudinal is, if nothing else is mentioned, longitudinal along the length of the frame. It is to be understood that the arrangement shown in a horizontal orientation is not the normal orientation as the window is installed.

**[0015]** To protect the interior and the components of

the window itself and to ascertain weather-proof transition to the surrounding roofing, the roof window comprises a covering, including flashing members (not shown), cladding and covering elements of which a frame side covering element 1b' and sash side covering element 2b' are shown. The parts of the covering of the prior art roof window are connected to the frame and the sash, and to the hinge in a hinge and covering assembly as described in detail in the above-mentioned embodiment of EP 2 751 354 B1. The prior art depictions of Figs 1 and 2 correspond to Applicant's published European patent application EP 3 252 250 A1. As seen in these figures, connection of the frame side covering element 1b' and sash side covering element 2b' to the respective hinge part of the hinge 10' is carried out by a snap anchor 60', 70'. Referring back to Fig. 2, in which it also emerges how the frame side covering element 1b' and sash side covering element 2b' interact with each other; a cranked portion 2c' of the sash side covering element 2b' ensures a tight and flush transition between the sash side covering element 2b' and the frame side covering element 1b' in the closed position of the roof window. At the same time, the movement pattern of the hinge allows that the sash side covering element 2b' is able to be retracted from its position under the frame side covering element 1b' during the opening movement of the sash 2 relative to the frame 1, and conversely, be inserted under the frame side covering element 1b' at the final stage of the closing movement.

**[0016]** In the following, a covering arrangement of embodiments of the roof window according to the invention will be described in some detail. Reference will be made to the roof window as comprising the frame 1, the sash 2 configured to be moved between a closed position and an open position, in which the sash 2 assumes an angle relative to the frame 1, and a set of hinges 10 corresponding to the components described in the above.

**[0017]** Thus, the covering arrangement includes a frame side covering element generally designated 11 having a top portion 111 and an end edge 115. A sash side covering element generally designated 12 has a top portion 121 and an end edge 125 facing the end edge 115 of the frame side covering element 11 to form a gap 15. It is understood that the dimensions of the gap 15 will vary according to manufacturing tolerances, not only due to the covering arrangement itself but also of other components of the roof window. Furthermore, a gap is present between the two side covering elements 11, 12 both when the sash is open and closed, but in the following, the gap 15 will be referred to as the space between the end edges 115, 125 of the respective frame and sash side covering elements. The covering arrangement is configured to cover at least the hinge (not shown) in the closed position of the sash 2, but also other components of the roof window such as the frame and sash side members. Each of the frame and sash side covering elements 11 and 12 has an external side facing the outdoor and an internal side facing the indoor.

**[0018]** According to the invention, a central feature is that the covering arrangement includes at least one transition element 13, 14 connected to one of the frame side covering element 11 and the sash side covering element 12, near or at the respective end edge 115, 125 of the frame side covering element 11 or the sash side covering element 12.

**[0019]** In the embodiment shown, the at least one transition element includes a first transition element 13 connected to the sash side covering element 12 and having a first venturi portion 138 configured to face an interior side of the top portion 112 of the frame side covering element 11 in the closed position of the sash 2 to provide a constricted section between an inner channel section 17 and an outer channel section 16, nearest said cap 15.

**[0020]** More specifically, the first venturi portion 138 is formed on a flange portion 137 of the first transition element 13, said flange portion 137 being formed in conjunction with an offsetting portion 136 adjacent a top portion 131 configured to abut an interior side of a top portion 121 of the sash side covering element 12 near the end edge 125 thereof.

**[0021]** In principle, the first transition element may be formed in any suitable manner; however, it is preferred that the first transition element 13 as shown has an inner side portion 133 to match a corresponding inner side portion 123 of the sash side covering element 12. Furthermore, the first transition element 13 here has a drain portion 134 to match a corresponding drain portion 124 of the sash side covering element 12 and to be positioned in extension of a corresponding drain portion 114 of the frame side covering element 11. Finally, the first transition element 13 comprises an extended portion 139. The extended portion 139 ensures safe retention and guidance of the first transition element 13 in the cooperation with the sash and frame side covering elements 12, 11.

**[0022]** Another advantageous feature of the shown embodiment of the invention is that the first transition element 13 comprises a breaker portion 135 configured to be located in the gap 15 between the respective end edges 115, 125 of the frame side covering element 11 and the sash side covering element 12 in the closed position of the sash 2. The breaker portion 135 here comprises a breaker back plate 135a extending at the end edge 125 of the sash side covering element 11 and protruding above the external side of the top portion 121 thereof. Furthermore, the breaker portion 135 comprises a plurality of breaker vanes 135b, preferably located at an angle to said breaker plate 135a, forming a corresponding plurality of breaker vane interstices 135c. In the case of rain and other precipitation, some of the resultant water will flow in the drain portions 114, 134, 114 whereas some of the water will flow along the top portion of the frame side covering element 11, then meet with the breaker back plate 135a, and finally be distributed by the breaker vane interstices 135c.

**[0023]** Referring in particular to Figs 8 to 11, a second transition element 14 is connected to the frame side cov-

ering element 11 and comprising a flat portion 141 and a second venturi portion 142 to be located opposite the first venturi portion 138 in the constricted section between the inner channel section 17 and the outer channel section 16 in the closed position of the sash 2.

**[0024]** As the transition element or elements 13, 14 are provided separately from the sash and frame side covering elements 12, 11, a connection must be carried out in order to retain the components to each other. In principle, this could be performed by traditional mechanical techniques such as snap locking or friction engagement, possibly in support of adhesive connections, but these techniques do not create a roof window as claimed.

**[0025]** According to the invention, each transition element 13, 14 is connected to the respective sash or frame side covering element 12, 11 by the use of a) engraving an interior surface of the covering element to provide an engraved surface with at least one cavity by subjecting the covering element to a laser beam at a polar angle; and b) attaching the at least one transition element 13, 14 to the covering element 12, 11 by introducing a portion of the transition element into the least one cavity. Details of such joining techniques are found in Applicant's co-pending international application No. PCT/DK2017/050356.

**[0026]** It is even possible to form the transition element or elements 13, 14 integrally with a snap anchor (corresponding to above prior art elements 60' and 70') configured to connect with a corresponding receiving section of a respective hinge part of the set of hinges.

**[0027]** Finally, it is also possible to include further elements into the selection of transition elements, including sealings. Such sealings may for instance include flaps forming one-way valves, allowing water present under the covering elements to exit but blocking the passage of water and other precipitation from entering.

**[0028]** The invention is not limited to the embodiments shown and described in the above, but various modifications and combinations may be carried out within the limits defined by the claims.

**[0029]** The invention further provides a method of providing a roof window with improved covering arrangement, comprising the steps of: providing a frame (1) and a sash (2), providing a covering arrangement including a frame side covering element (11) having a top portion (111) and an end edge (115), and a sash side covering element (12) having a top portion (121) and an end edge (125), providing at least one transition element (13, 14),

a) engraving an interior surface of at least one of said covering elements (11, 12) to provide an engraved surface with at least one cavity by subjecting the covering element to a laser beam at a polar angle,  $\alpha_1$ ; and

b) attaching the at least one transition element (13, 14) to the covering element (12, 11) by introducing a portion of the transition element into the least one cavity.

## List of reference numerals

### [0030]

5	1	frame
		1a frame side member
	2	sash
		2a sash side member
	3	pane
10	1b'	prior art frame side covering element
	2b'	prior art sash side covering element
	10'	hinge
	60', 70'	prior art snap anchors
	11	frame side covering element
15		111 top portion
		112 outer side portion
		113 inner side portion
		114 drain portion
		115 end edge
20	12	sash side covering element
		121 top portion
		122 outer side portion
		123 inner side portion
		124 drain portion
25		125 end edge
	13	first transition element
		131 top portion
		133 inner side portion
		134 drain portion
30		135 breaker portion,
		135a breaker back plate
		135b breaker vanes
		135c breaker vane interstices
35		136 offsetting portion
		137 flange portion
		138 first venturi portion
		139 extended portion
	14	second transition element
		141 flat portion
40		142 second venturi portion
	15	gap
	16	outer channel section
	17	inner channel section

### Claims

1. A roof window, particularly for installation in an inclined roof surface, comprising
  - a frame (1),
  - a sash (2) configured to be moved between a closed position and an open position, in which the sash (2) assumes an angle relative to the frame (1),
  - a set of hinges (10), and
  - a covering arrangement including a frame side covering element (11) having a top portion (111) and an end edge (115), and a sash side covering element (12) having a top portion (121) and an end edge (125)

facing the end edge (115) of the frame side covering element (11) to form a gap (15), said covering arrangement being configured to cover at least one of said hinges (10) in the closed position of the sash (2), wherein

the covering arrangement includes at least one separate transition element (13, 14) connected to one of the frame side covering element (11) and the sash side covering element (12), near or at the respective end edge (115, 125) of the frame side covering element (11) or the sash side covering element (12), and that said at least one transition element (13, 14) is configured to influence the flow conditions at or near the gap (15) in the closed position of the sash (2),

**characterised in that**

said at least one transition element (13, 14) is connected to the respective sash or frame side covering element (12, 11) by the use of a) engraving an interior surface of the covering element to provide an engraved surface with at least one cavity by subjecting the covering element to a laser beam at a polar angle,  $\alpha_1$ ; and b) attaching the at least one transition element (13, 14) to the covering element (12, 11) by introducing a portion of the transition element into the least one cavity.

2. A roof window according to claim 1, wherein said at least one transition element (13, 14) is formed integrally with a snap anchor configured to connect with a corresponding receiving section of a respective hinge part of the set of hinges.

3. A method of providing a roof window with improved covering arrangement, comprising the steps of:

providing a frame (1) and a sash (2),  
 providing a covering arrangement including a frame side covering element (11) having a top portion (111) and an end edge (115), and a sash side covering element (12) having a top portion (121) and an end edge (125),  
 providing at least one transition element (13, 14),

a) engraving an interior surface of at least one of said covering elements (11, 12) to provide an engraved surface with at least one cavity by subjecting the covering element to a laser beam at a polar angle,  $\alpha_1$ ;  
 and

b) attaching the at least one transition element (13, 14) to the covering element (12, 11) by introducing a portion of the transition element into the least one cavity.

**Patentansprüche**

1. Dachfenster, insbesondere zur Installation in einer Schrägdachfläche, das Folgendes umfasst:

einen Rahmen (1),  
 einen Flügelrahmen (2), der dazu konfiguriert ist, zwischen einer geschlossenen Stellung und einer geöffneten Stellung, in der der Flügelrahmen (2) einen Winkel bezüglich des Rahmens (1) einnimmt, bewegt zu werden,  
 einen Satz Scharniere (10), und  
 eine Abdeckungsanordnung, die ein Rahmenseitenabdeckungselement (11) mit einem oberen Abschnitt (111) und einem Endrand (115) und ein Flügelrahmenseitenabdeckungselement (12) mit einem oberen Abschnitt (121) und einem Endrand (125), der zu dem Endrand (115) des Rahmenseitenabdeckungselements (11) zur Bildung eines Spalts (15) weist, umfasst, wobei die Abdeckungsanordnung dazu konfiguriert ist, zumindest die Scharniere (10) in der geschlossenen Stellung des Flügelrahmens (2) abzudecken, wobei die Abdeckungsanordnung mindestens ein separates Übergangselement (13, 14) umfasst, das mit dem Rahmenseitenabdeckungselement (11) oder dem Flügelrahmenseitenabdeckungselement (12) in der Nähe von oder an dem jeweiligen Endrand (115, 125) des Rahmenseitenabdeckungselements (11) oder des Flügelrahmenseitenabdeckungselements (12) verbunden ist, und das mindestens eine Übergangselement (13, 14) dazu konfiguriert ist, die Strömungsbedingungen an oder in der Nähe von dem Spalt (15) in der geschlossenen Stellung des Flügelrahmens (2) zu beeinflussen,

**dadurch gekennzeichnet, dass**

das mindestens eine Übergangselement (13, 14) mit dem jeweiligen Flügelrahmen bzw. Rahmenseitenabdeckungselement (12, 11) durch Einsatz von a) Gravieren einer Innenfläche des Abdeckungselements zur Bereitstellung einer gravierten Fläche mit mindestens einem Hohlraum, indem das Abdeckungselement einem Laserstrahl mit einem Polarwinkel,  $\alpha_1$ , ausgesetzt wird; und b) Anbringen des mindestens einen Übergangselements (13, 14) an dem Abdeckungselement (12, 11) durch Einführen eines Abschnitts des Übergangselements in den mindestens einen Hohlraum verbunden wird.

2. Dachfenster nach Anspruch 1, wobei das mindestens eine Übergangselement (13, 14) integral mit einem Schnappanker ausgebildet ist, der zur Verbindung mit einem entsprechenden Aufnahmebereich eines jeweiligen Scharnierteils des Satzes von Scharnieren konfiguriert ist.

3. Verfahren zur Bereitstellung eines Dachfensters mit einer verbesserten Abdeckungsanordnung, das die folgenden Schritte umfasst:

Bereitstellen eines Rahmens (1) und eines Flügelrahmens (2),  
 Bereitstellen einer Abdeckungsanordnung, die ein Rahmenseitenabdeckungselement (11) mit einem oberen Abschnitt (111) und einem Endrand (115) und ein Flügelrahmenseitenabdeckungselement (12) mit einem oberen Abschnitt (121) und einem Endrand (125) umfasst, Bereitstellen mindestens eines Übergangselements (13, 14),

- a) Gravieren einer Innenfläche mindestens eines der Abdeckungselemente (11, 12) zur Bereitstellung einer gravierten Fläche mit mindestens einem Hohlraum, indem das Abdeckungselement einem Laserstrahl mit einem Polarwinkel,  $\alpha$ , ausgesetzt wird; und  
 b) Anbringen des mindestens einen Übergangselements (13, 14) an dem Abdeckungselement (12, 11) durch Einführen eines Abschnitts des Übergangselements in den mindestens einen Hohlraum.

### Revendications

1. Fenêtre de toit, en particulier pour l'installation dans une surface de toit inclinée, comprenant un cadre (1), un châssis (2) configuré pour être déplacé entre une position fermée et une position ouverte dans laquelle le châssis (2) est orienté suivant un angle par rapport au cadre (1), un ensemble de charnières (10), et un agencement de couverture comportant un élément de couverture latérale de cadre (11) ayant une portion supérieure (111) et un bord d'extrémité (115), et un élément de couverture latérale de châssis (12) ayant une portion supérieure (121) et un bord d'extrémité (125) faisant face au bord d'extrémité (115) de l'élément de couverture latérale de cadre (11) pour former un espace (15), ledit agencement de couverture étant configuré pour couvrir au moins une desdites charnières (10) dans la position fermée du châssis (2), l'agencement de couverture comportant au moins un élément de transition séparé (13, 14) connecté à l'un parmi l'élément de couverture latérale de cadre (11) et l'élément de couverture latérale de châssis (12), à proximité ou au niveau du bord d'extrémité respectif (115, 125) de l'élément de couverture latérale de cadre (11) ou de l'élément de couverture latérale de châssis (12), et ledit au moins un élément de transition (13, 14) étant configuré pour influencer

les conditions d'écoulement au niveau ou à proximité de l'espace (15) dans la position fermée du châssis (2),

### caractérisé en ce que

ledit au moins un élément de transition (13, 14) est connecté à l'élément de couverture latérale de châssis ou de cadre (12, 11) respectif par l'utilisation de a) la gravure d'une surface intérieure de l'élément de couverture pour fournir une surface gravée avec au moins une cavité en soumettant l'élément de couverture à un faisceau laser à un angle polaire,  $\alpha$ ; et b) la fixation de l'au moins un élément de transition (13, 14) à l'élément de couverture (12, 11) en introduisant une partie de l'élément de transition dans l'au moins une cavité.

2. Fenêtre de toit selon la revendication 1, ledit au moins un élément de transition (13, 14) étant formé d'un seul tenant avec un ancrage à déclic configuré pour se connecter à une section de réception correspondante d'une partie de charnière respective de l'ensemble de charnières.
3. Procédé pour fournir une fenêtre de toit avec un agencement de couverture amélioré, comprenant les étapes consistant à :

fournir un cadre (1) et un châssis (2),  
 fournir un agencement de couverture comprenant un élément de couverture latérale de cadre (11) ayant une portion supérieure (111) et un bord d'extrémité (115), et un élément de couverture latérale de châssis (12) ayant une portion supérieure (121) et un bord d'extrémité (125), fournir au moins un élément de transition (13, 14),

- a) graver une surface intérieure d'au moins un desdits éléments de couverture (11, 12) pour fournir une surface gravée avec au moins une cavité en soumettant l'élément de couverture à un faisceau laser à un angle polaire,  $\alpha$ ; et  
 b) fixer l'au moins un élément de transition (13, 14) à l'élément de couverture (12, 11) en introduisant une partie de l'élément de transition dans l'au moins une cavité.

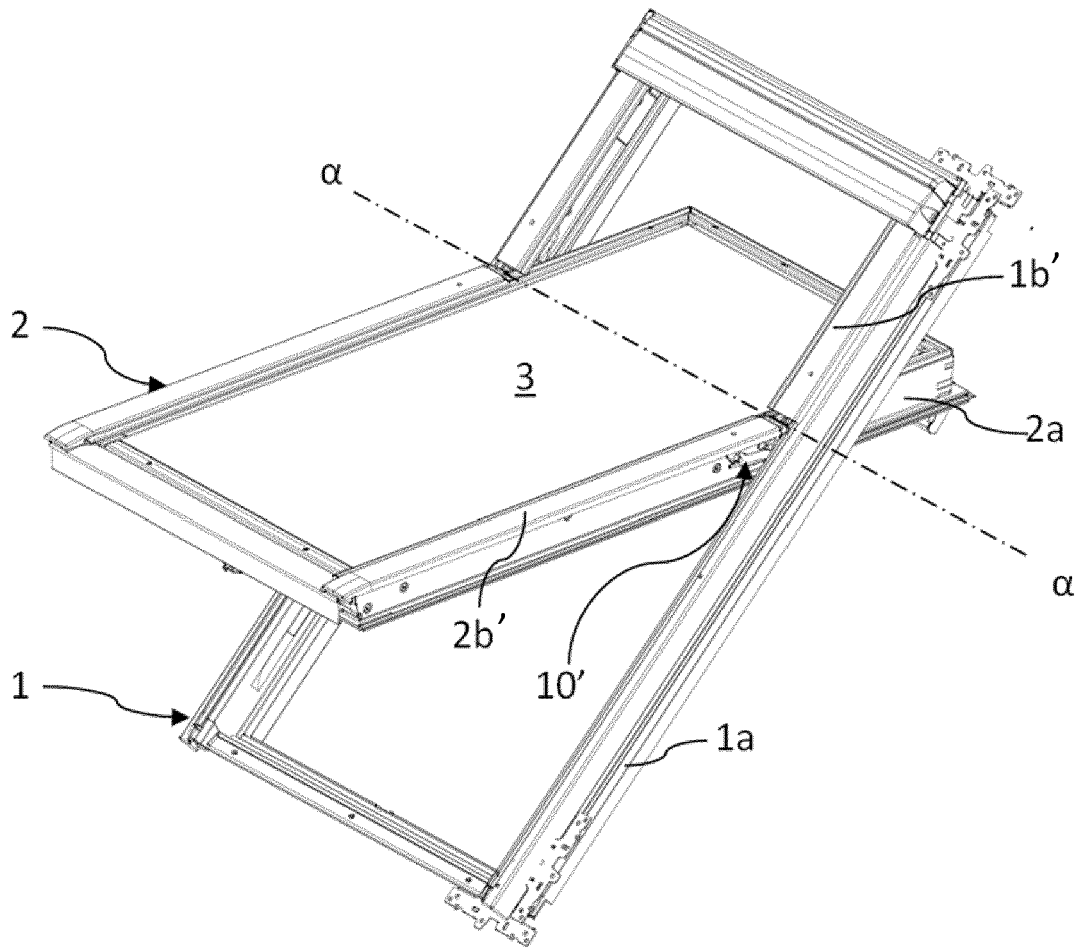

Fig. 1 (Prior art)

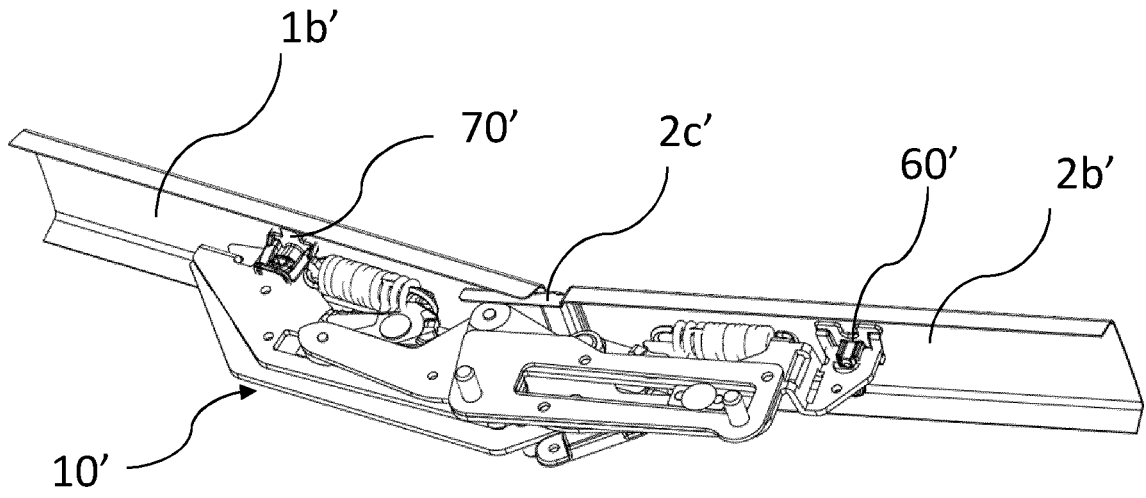

Fig. 2 (Prior art)

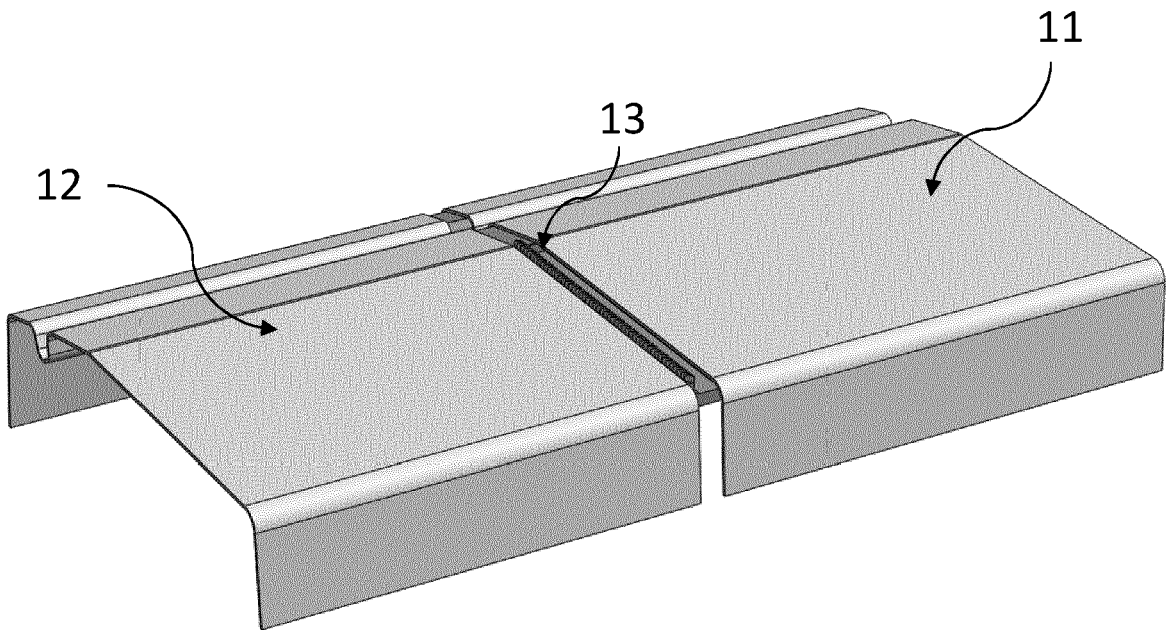

Fig. 3

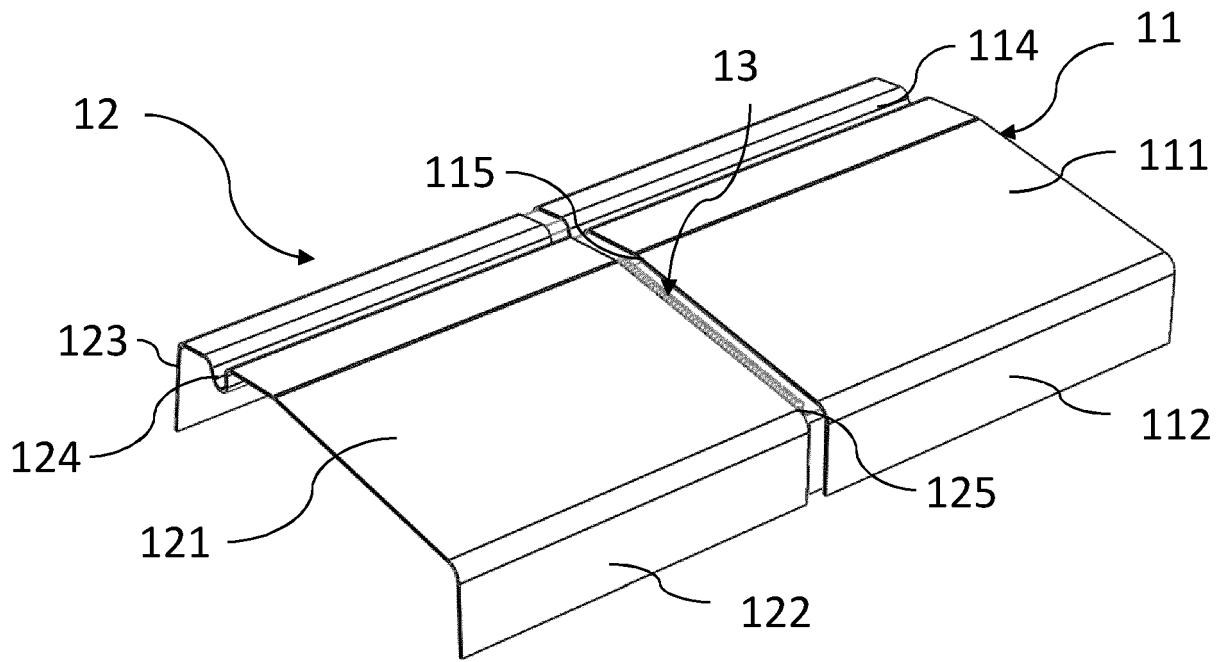

Fig. 4

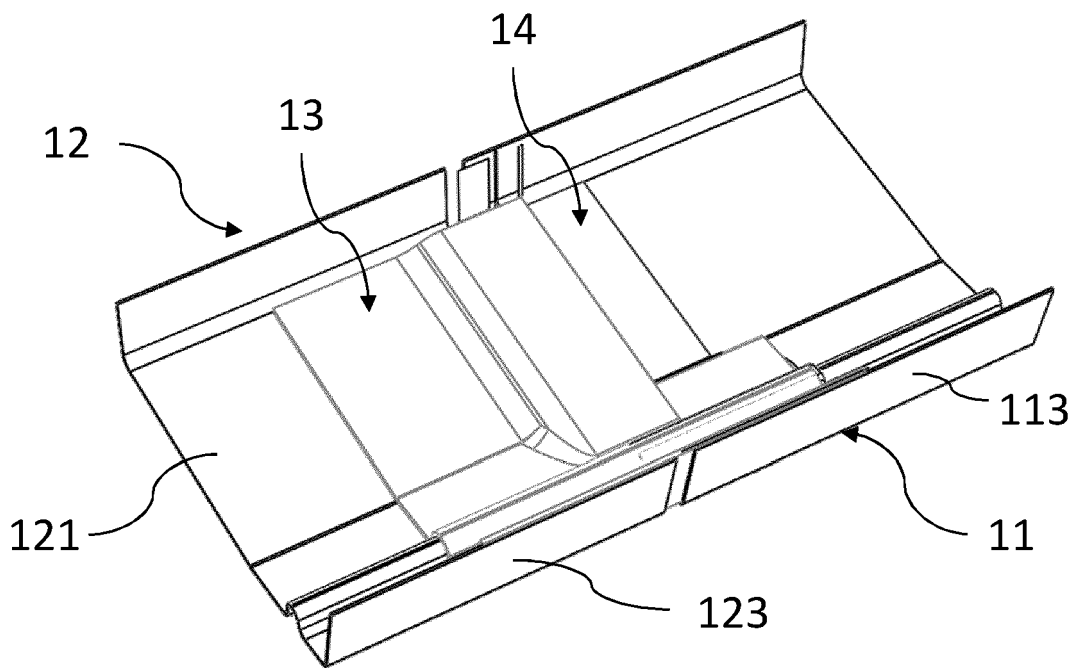
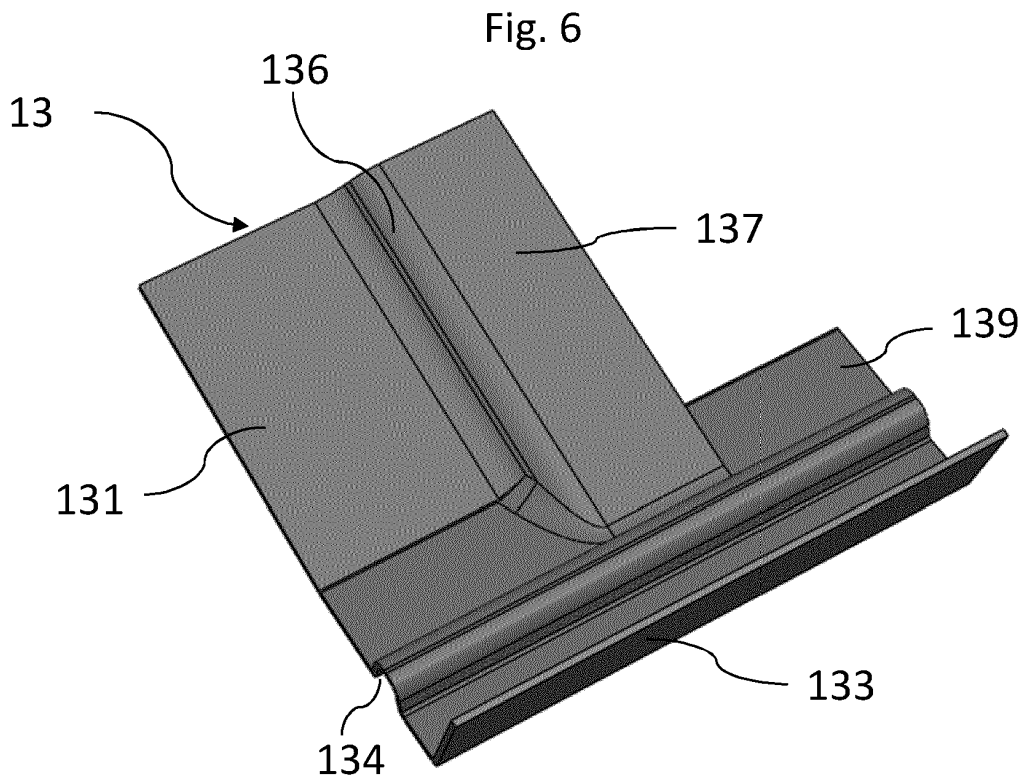
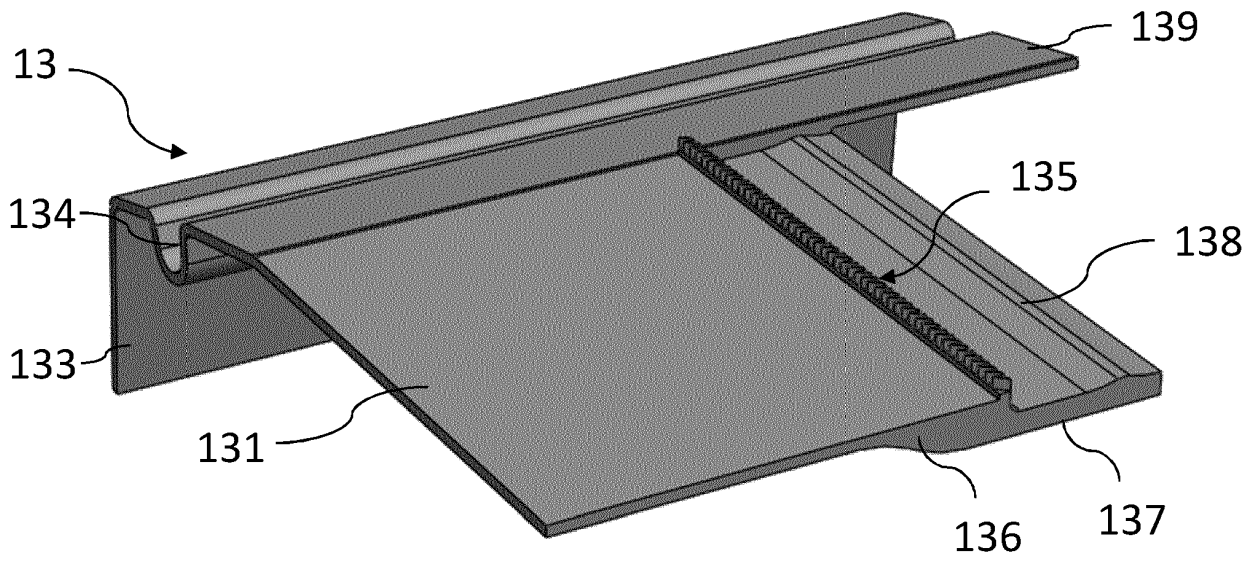

Fig. 5



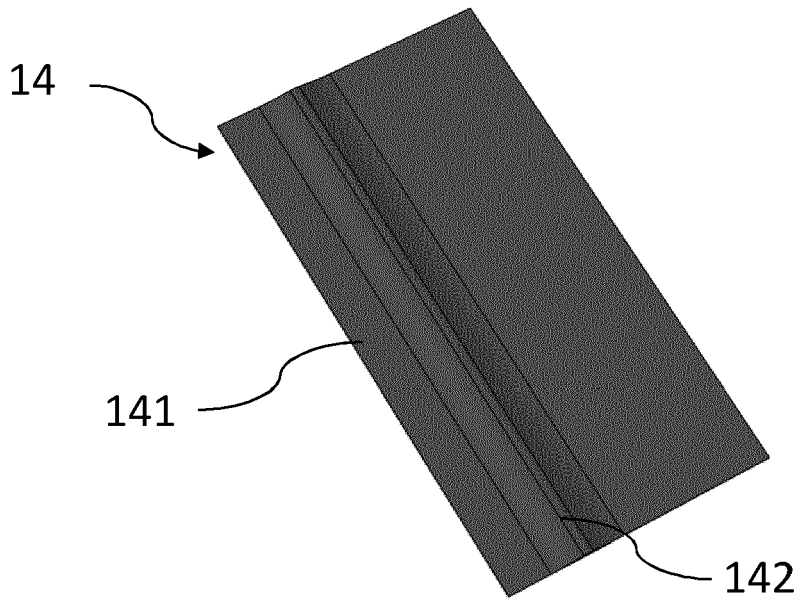

Fig. 8

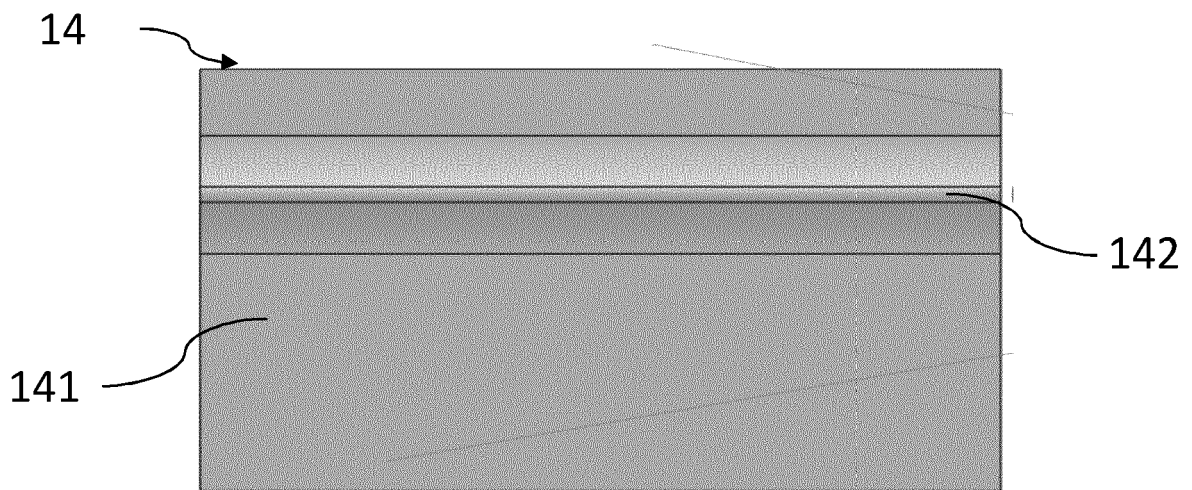

Fig. 9



**REFERENCES CITED IN THE DESCRIPTION**

*This list of references cited by the applicant is for the reader's convenience only. It does not form part of the European patent document. Even though great care has been taken in compiling the references, errors or omissions cannot be excluded and the EPO disclaims all liability in this regard.*

**Patent documents cited in the description**

- GB 1473570 A [0002]
- DE 2628691 A1 [0002]
- EP 0352206 A1 [0002]
- EP 1070179 B1 [0003]
- DK 201570717 [0012]
- EP 1038083 B1 [0012]
- EP 1781883 B1 [0012]
- EP 2770146 A1 [0012]
- EP 2770149 A1 [0012]
- EP 2751354 B1 [0015]
- EP 3252250 A1 [0015]
- DK 2017050356 W [0025]