

**(12) STANDARD PATENT**  
**(19) AUSTRALIAN PATENT OFFICE**

(11) Application No. **AU 2012209090 B2**

(54) Title  
**Systems and methods for maintaining a narrow body lumen**

(51) International Patent Classification(s)  
**A61B 1/00** (2006.01)                      **A61B 1/045** (2006.01)  
**A61B 1/012** (2006.01)                   **A61B 18/24** (2006.01)  
**A61B 1/04** (2006.01)

(21) Application No: **2012209090**                      (22) Date of Filing: **2012.01.25**

(87) WIPO No: **WO12/103266**

(30) Priority Data

(31) Number	(32) Date	(33) Country
<b>61/435,945</b>	<b>2011.01.25</b>	<b>US</b>

(43) Publication Date: **2012.08.02**

(44) Accepted Journal Date: **2016.03.24**

(71) Applicant(s)  
**NVision Medical Corporation**

(72) Inventor(s)  
**Sarna, Surbhi**

(74) Agent / Attorney  
**Spruson & Ferguson, L 35 St Martins Tower 31 Market St, Sydney, NSW, 2000**

(56) Related Art  
**US 5662587**

(12) INTERNATIONAL APPLICATION PUBLISHED UNDER THE PATENT COOPERATION TREATY (PCT)

(19) World Intellectual Property  
Organization  
International Bureau



(10) International Publication Number  
**WO 2012/103266 A3**

(43) International Publication Date  
2 August 2012 (02.08.2012)

(51) International Patent Classification:

A61B 1/00 (2006.01) A61B 1/045 (2006.01)  
A61B 1/012 (2006.01) A61B 18/24 (2006.01)  
A61B 1/04 (2006.01)

(21) International Application Number:

PCT/US2012/022619

(22) International Filing Date:

25 January 2012 (25.01.2012)

(25) Filing Language:

English

(26) Publication Language:

English

(30) Priority Data:

61/435,945 25 January 2011 (25.01.2011) US

(71) Applicant (for all designated States except US): **NVISION MEDICAL CORPORATION** [US/US]; 14224 Springer Avenue, Saratoga, CA 95070 (US).

(72) Inventor; and

(75) Inventor/Applicant (for US only): **SARNA, Surbhi** [US/US]; c/o 14224 Springer Avenue, Saratoga, CA 95070 (US).

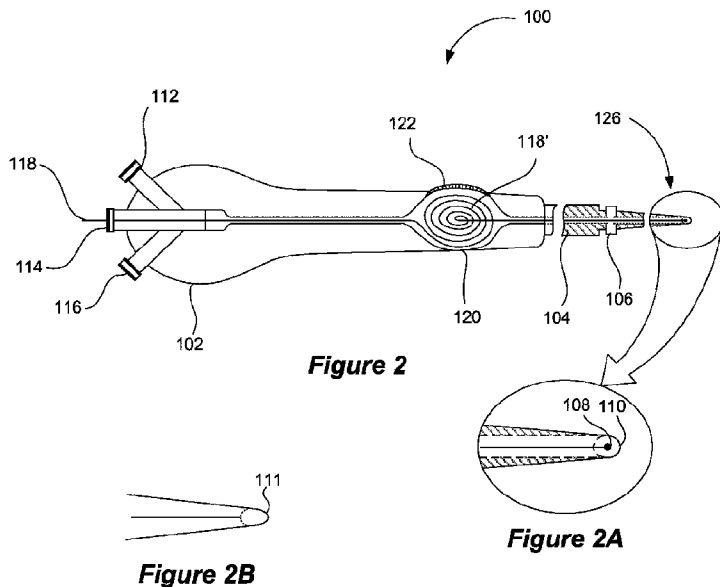
(74) Agent: **BEDI, Harmohinder S.**; EcoTech Law Group, P.C., 201 Spear St. Ste. 1100, San Francisco, CA 94105 (US).

(81) Designated States (unless otherwise indicated, for every kind of national protection available): AE, AG, AL, AM, AO, AT, AU, AZ, BA, BB, BG, BH, BR, BW, BY, BZ, CA, CH, CL, CN, CO, CR, CU, CZ, DE, DK, DM, DO, DZ, EC, EE, EG, ES, FI, GB, GD, GE, GH, GM, GT, HN, HR, HU, ID, IL, IN, IS, JP, KF, KG, KM, KN, KP, KR, KZ, LA, LC, LK, LR, LS, LT, LU, LY, MA, MD, ME, MG, MK, MN, MW, MX, MY, MZ, NA, NG, NI, NO, NZ, OM, PE, PG, PH, PL, PT, QA, RO, RS, RU, RW, SC, SD, SE, SG, SK, SL, SM, ST, SV, SY, TH, TJ, TM, TN, TR, TT, TZ, UA, UG, US, UZ, VC, VN, ZA, ZM, ZW.

(84) Designated States (unless otherwise indicated, for every kind of regional protection available): ARIPO (BW, GH, GM, KE, LR, LS, MW, MZ, NA, RW, SD, SL, SZ, TZ, UG, ZM, ZW), Eurasian (AM, AZ, BY, KG, KZ, MD, RU, TJ, TM), European (AL, AT, BE, BG, CH, CY, CZ, DE, DK, EE, ES, FI, FR, GB, GR, HR, HU, IE, IS, IT, LT, LU, LV, MC, MK, MT, NL, NO, PL, PT, RO, RS, SE, SI, SK, SM, TR), OAPI (BF, BJ, CF, CG, CI, CM, GA, GN, GQ, GW, ML, MR, NE, SN, TD, TG).

[Continued on next page]

(54) Title: SYSTEMS AND METHODS FOR MAINTAINING A NARROW BODY LUMEN



(57) Abstract: Devices and processes for maintaining a narrow body lumen are described. One embodiment of the inventive device includes: (i) a hydraulic propulsion mechanism for propelling an imaging portion or a therapeutic portion through the narrow body lumen; and (ii) a retrieval mechanism for retrieving the imaging portion or the therapeutic portion from the narrow body lumen.

WO 2012/103266 A3



---

**Published:**

**(88) Date of publication of the international search report:**

15 November 2012

- *with international search report (Art. 21(3))*
- *before the expiration of the time limit for amending the claims and to be republished in the event of receipt of amendments (Rule 48.2(h))*

**SYSTEMS AND METHODS FOR MAINTAINING A NARROW BODY LUMEN****RELATED APPLICATION**

The application claims priority from U.S. Provisional Application having Serial No.  
5 61/435,945, which was filed on January 25, 2011 and which is incorporated herein by reference  
for all purposes.

**FIELD OF THE INVENTION**

The present invention relates generally to maintenance of a narrow body lumen. More  
particularly, the present invention relates to systems or methods for diagnostic imaging or  
10 therapeutic treatment to effectively maintain the narrow body lumen.

**BACKGROUND OF THE INVENTION**

For a variety of reasons, occlusions often develop in narrow body lumens (*i.e.*, the channel of a  
tubular-shaped anatomical structure, such as the fallopian tubes, intestines, and coronary arteries)  
and have medically-relevant consequences on the body. Conventional techniques employed to  
15 maintain the health of fallopian tubes, as an example of a narrow body lumen, are described  
below.

Fallopian tubes are vessel-like, non-fluid filled structures that extend from the uterus to  
the ovaries. On average, fallopian tubes measure between eight and ten centimeters in length.  
The inner diameter of the tube varies significantly depending on the segment of the tube, with a  
20 minimum inner diameter of approximately one millimeter and a maximum of six millimeters.  
Along the length of the lumen of the fallopian tube millions of microscopic hair-like cilia pulsate  
in wave-like motions at the rate of hundreds of times per second. This motion assists the egg,  
delivered from the ovaries during ovulation, in passing through the tube to the uterine cavity.  
Cells located in the tube's inner lining (endothelium) supply the egg with vital nourishment and  
25 provide lubrication along the path. It is within the fallopian tube that the sperm first contacts the  
egg. If the egg is not fertilized within twenty-four to thirty-six hours of reaching the fallopian  
tube, the egg deteriorates and is removed from the tube by the body's immune system.

Disease of fallopian tube often presents as occlusion or thickening of the fallopian tube  
wall and can be caused by infection as well as scarring. In particular, pelvic inflammatory  
30 disease (PID), urinary tract infections (UTI) as well as sexually transmitted infections (STI) may  
cause severe inflammation that in turn blocks the tube. Endometriosis may also cause occlusion  
when the uterine lining grows into the fallopian tube. An appendectomy or other abdominal  
surgery may further similarly lead to occluded fallopian tubes. Regardless of the manner in

which it is formed, an occlusion can lead to a hydrosalpinx, where the tube increases in diameter because it is filled with fluid. The presence of fluid prevents both the egg and sperm from traveling through the fallopian tube, preventing fertilization. It is believed that hydrosalpinx can reduce the success rate of in-vitro fertilization by up to 8%.

5           In the US alone, there are at least seven million cases of infertility annually and an estimated 25-40% of these cases are caused by fallopian tube occlusion or disease. Hysterosalpingogram (HSG), a procedure most commonly utilized to diagnose fallopian tube disease, requires a radiologist to inject dye into the uterus under x-ray guidance. The dye enters the fallopian tube through the ostia (openings) located in the uterus. If a woman's fallopian tubes  
10 are patent (open), dye will flow into the peritoneal cavity. In order to visualize the fluid path, a series of timed x-rays are taken.

          Unfortunately, this procedure suffers from several drawbacks. By way of example, HSG suffers from a high false negative rate of 30% and a high false positive rate of 40% due to tubal spasms or shadow (noise) in the x-rays. This often necessitates further procedures. This high rate  
15 of inaccuracy is also partly due to the fact that radiologists are not as intimate with the tortuosity and topography of the fallopian tube as gynecologist or reproductive endocrinologist.

          As another example of a drawback, HSG is not conducted in-office by a gynecologist or reproductive endocrinologist, the primary caretaker of the patient, as it necessitates a substantial investment in x-ray capital equipment mostly found in hospitals. The patient typically first visits  
20 a gynecologist, who conducts a series of blood tests and determines whether HSG is necessary. If it is deemed necessary, then the patient schedules an appointment with the radiologist to have the HSG procedure administered. At the conclusion of the first procedure, the patient returns either to the gynecologist or reproductive endocrinologist to discuss the results. Because of the high inaccuracy rate associated with the HSG, the patient often returns to the radiologist for a second  
25 procedure, creating additional unnecessary costs for both the patient and hospital.

          As yet another example, patients often complain of pain and some are allergic to the dye used during the procedure. Furthermore, HSG must be conducted before day 12 of a woman's menstrual cycle because the dye may harm a potential full term pregnancy, which limits options for both doctor and patient and further extends the waiting period for a full infertility diagnosis,  
30 which is emotionally taxing to the patient and family.

          To overcome these drawbacks, different direct visualization techniques have been attempted. Figure 1 shows an endoscope, which uses conventional optical fiber imaging technology, as an exemplar attempt to achieve direct visualization of the fallopian tubes. In this figure, a female reproductive anatomy 10 undergoing imaging includes fallopian tubes 12,  
35 ovaries 14, uterus 16, uterine cavity 22, cervix 28 and fimbria 30. An imaging catheter shaft 20 is

introduced into a fallopian tube, which has a consistency of a wet paper towel. Catheter shaft 20 passes through fallopian tube ostia in the uterus 18, beyond which point the fallopian tube 12 is narrow and tortuous.

Unfortunately, the wet-paper-towel consistency does not provide adequate tactile feedback to a physician, who navigates catheter 20 through fallopian tube 12. As a result, during the imaging procedure, the physician is not aware of the undue pressure exerted against the fallopian tube, leading to perforation 24. To this end, Figure 1 shows a portion of catheter 26 protruding out of perforation 24 in fallopian tubes 12. Perforation of the fallopian tube may prevent eggs from the ovaries 14 of the patient from reaching the uterus 16 for fertilization, making perforation an unacceptable clinical adverse event in a patient who is actively attempting to conceive. In addition to running the risk of perforating the fallopian tubes, the imaging procedure described above involves several steps and is therefore viewed by physicians as convoluted and difficult to perform correctly. Furthermore, the wet paper towel consistency of the fallopian tubes prevents the attempted imaging procedure from obtaining a clear, focused image. Specifically, during imaging, the wet paper towel consistency causes the fallopian tubes' walls to "fold" over the endoscope's tip, making it difficult to maintain a sufficient distance between the endoscope's tip and the walls of the fallopian tubes to focus and take a clear picture.

Therefore, what is needed is a novel diagnostic and therapeutic system and method which allows for effective maintenance of a narrow body lumen, without suffering from the drawbacks encountered by the current and attempted systems and methods described above.

## **OBJECT OF THE INVENTION**

It is an object of the present invention to at least substantially satisfy one or more of the above needs.

## **SUMMARY OF THE INVENTION**

In one aspect the present invention provides a device for maintaining a narrow body lumen, comprising:

a hydraulic propulsion mechanism and at least one of an imaging portion or a therapeutic portion, said hydraulic propulsion mechanism configured for propelling said imaging portion or said therapeutic portion relative to said hydraulic propulsion mechanism and through the narrow

body lumen, said hydraulic propulsion mechanism including a shaft portion, wherein the narrow body lumen is distal of a distal end of said shaft portion;

wherein said imaging portion or said therapeutic portion, when propelled by said hydraulic propulsion mechanism, is driven distally from said distal end of said shaft portion and is distally spaced therefrom; and

a retrieval mechanism for retrieving said imaging portion or said therapeutic portion from said narrow body lumen.

In one embodiment of the present invention, the device further includes a handle portion, which receives one or more luers, one of which is designed to provide hydraulic pressure to hydraulically propel the imaging portion or the therapeutic portion through the narrow body lumen. The luer is preferably designed to receive a hydraulic propellant from a reservoir containing the hydraulic propellant.

The device may further include a wire luer, which is received by the handle portion and is designed to provide a wire for conveying electrical power and signals to facilitate an imaging function carried out by the imaging portion.

The device may further still include a seal-creating lure, which is received by the handle portion and is designed to create a seal to facilitate imaging or therapeutic treatment. In certain embodiments of the present invention, an inflatable object is used for creating a seal to facilitate imaging or therapeutic treatment. In these embodiments, the seal-creating lure may also be referred to as an inflation luer as it facilitates inflation of the inflatable body.

In another aspect, the present invention provides a narrow body lumen diagnostic device. The device includes: (i) a guide wire capable of providing light or sensing an image and for guiding a catheter to a target location, the guide wires including illuminating fibers or imaging fibers; and (ii) a catheter including imaging fibers if the guide wire includes illuminating fibers or the catheter including illuminating fibers if the guide wire includes imaging fibers.

In yet another aspect, the present invention provides a fallopian tube diagnostic device. The device includes: (i) a sensing lumen for providing a catheter including a sensing portion and an inflatable portion, and the sensing portion capable of sensing information about the fallopian tube; (ii) a solution lumen for providing a solution which facilitates sensing carried out by the sensing portion; and (iii) wherein, in an operational state of the fallopian tube diagnostic device,

the inflatable portion inflates to create a space around the sensing portion such that in presence of the solution, the sensing portion senses information regarding the fallopian tube. In certain preferred embodiments of the present invention, the device includes a therapeutic lumen to provide therapy to a localized region in the fallopian tube.

In yet another aspect the present invention provides a process of maintaining a narrow body lumen, said process comprising:

creating a seal inside or outside said narrow body lumen such that in presence of a hydraulic propellant, said narrow body lumen is pressurized to allow diagnostic imaging of said narrow body lumen using an imaging portion of an imaging device;

hydraulically propelling, using said hydraulic propellant, said imaging portion distally of a main body of a device and a location of said seal through said narrow body lumen;

imaging said narrow body lumen; and

retrieving said imaging portion from said narrow body lumen.

In a preferred embodiment of the present invention, the above-described process includes: (i) establishing a channel from outside the narrow body lumen to a proximal region of the narrow body lumen or a region that is proximate to the narrow body lumen; (ii) placing the imaging portion through the channel; and (iii) wherein the placing is carried out before the creating.

In yet another aspect, the present invention provides a process for maintaining a narrow body lumen. The process includes: (i) sealing the narrow body lumen to allow therapeutic treatment of the narrow body lumen using a therapeutic device; (ii) hydraulically propelling the therapeutic device through the narrow body lumen; (iii) treating the narrow body lumen; and (iv) retrieving the therapeutic device from the narrow body lumen.

The process may further include: (i) defining a channel from outside the narrow body lumen to a proximal region of the narrow body lumen or a region that is proximate to the narrow body lumen; (ii) placing the therapeutic device through the channel; and (iii) wherein the placing is carried out before the sealing.

In yet another aspect, the present invention provides a process of maintaining a fallopian tube. The process includes: (i) steering a guide wire through a channel to a target location within guidewire a catheter for providing light or imaging; (iii) imaging or illuminating the

fallopian tube using the guide wire and the catheter; and (iv) retrieving the catheter from the fallopian tube.

The process may further includes: (i) removing the guidewire from a guidewire lumen; and (ii) introducing a therapy or a saline flush through the guidewire lumen.

The construction and method of operation of the invention, however, together with additional objects and advantages thereof, will be best understood from the following descriptions of specific embodiments when read in connection with the accompanying figures.

### **BRIEF DESCRIPTION OF THE DRAWINGS**

Preferred embodiments of the present invention will now be described, by way of example only, with reference to the accompanying drawings:

Figure 1 shows an endoscope being navigated through the fallopian tubes and major organs of a female reproductive system.

Figure 2 shows a side-sectional view of a diagnostic device, according to one embodiment of the present invention, in a non-operational state.

Figure 2A shows a magnified view of a distal tip of a shaft portion of the diagnostic device shown in Figure 2.

Figure 2B shows a side-sectional view of a distal tip of a shaft portion of a therapeutic device, according to one embodiment of the present invention.

Figure 3 shows a side-sectional view of a shaft portion, according to another embodiment of the present invention, in an operational state of the diagnostic device of Figure 2.

Figure 4A is a perspective view of two different ovular-shaped distal tips, according to certain embodiments of the present invention, used in a guidewire-based diagnostic imaging device or in a guidewire lumen-based therapeutic intervention device.

Figure 4B is a top view of the distal tip shown in Figure 4A.

5 Figure 5A is a perspective view of a conical-shaped distal tip, according to one embodiment of the present invention, used in a guidewire-based diagnostic imaging device or in a guidewire lumen-based therapeutic intervention device.

Figure 5B is a top view of the distal tip shown in Figure 5A.

10 Figure 6A is a side view of a non-inflated conical-shaped distal tip, according to one embodiment of the present invention, used in a non-guidewire-based diagnostic imaging device or in a non-guidewire lumen-based therapeutic intervention device.

Figure 6B is a side view of the conical-shaped distal tip of Figure 6A in its inflated state.

15 Figure 7A is a side view of a non-inflated ovular-shaped distal tip, according to one embodiment of the present invention, used in a non-guidewire-based diagnostic imaging device or in a non-guidewire lumen-based therapeutic intervention device.

Figure 7B is a side view of the ovular-shaped distal tip of Figure 7A in its inflated state.

Figure 8A is a side view of a non-inflated dome-shaped distal tip, according to one embodiment of the present invention, used in a non-guidewire-based diagnostic imaging device or in a non-guidewire lumen-based therapeutic intervention device.

20 Figure 8B is a side view of the dome-shaped distal tip of Figure 8A in its inflated state.

Figure 8C shows certain major components, according to one embodiment of the present invention, in the distal tip as shown in Figure 8B.

Figure 9 shows a process flow diagram, according to one embodiment of the present invention that uses a hydraulic propulsion mechanism for diagnostic imaging.

25 Figure 10 shows a process flow diagram, according to one embodiment of the present invention that uses a guide wire mechanism for diagnostic imaging.

#### **DETAILED DESCRIPTION OF THE PREFERRED EMBODIMENTS**

30 In the following description, numerous specific details are set forth in order to provide a thorough understanding of the present invention. It will be apparent, however, to one skilled in the art that the present invention may be practiced without limitation to some or all of these specific details. In other instances, well-known process steps have not been described in detail in order to not unnecessarily obscure the invention.

In certain embodiments, the present invention provides novel systems and methods for accurate real time-visualization, which dynamically diagnose malfunction of the fallopian tubes.

In preferred embodiments of the present invention, a single-use, disposable product and its associated procedure overcomes the many drawbacks encountered with current and attempted diagnostic approaches. The present inventions' more accurate, dynamic procedure may be conducted in an office of a gynecologist or a reproductive endocrinologist, who is typically the first and main point of contact for an infertility patient, understands the anatomy in question, and is better trained to dynamically change or repeat steps in the procedure if further clarification is needed. As a result, the number of office visits and costs to both the patient and hospital are significantly reduced, and at the same time, convenience to the parties involved is significantly increased. Furthermore, the high false positive rate of 20% to 40% encountered by the conventional diagnostic systems and procedures is also reduced by the present inventions' ability to directly visualize the fallopian tubes.

Preferred embodiments of the present invention recognize that to carry out certain initial steps of the inventive procedures, conventional diagnostic procedures may be relied upon to an extent. By way of example, certain inventive procedures require visualization of the openings (ostia) of the fallopian tubes in the uterus so that the tubes may be accessed. Those skilled in the art will recognize that although conventional hysteroscopes were primarily used to evaluate and maintain the health of a uterus, due to recent advancements in less invasive sterilization procedures such as Essure and Adiana (during which the tube is purposely occluded), a large numbers (*e.g.*, up to 7,500 for the Essure alone) of gynecologists and reproductive endocrinologists have adopted the hysteroscopes to visualize, and trans-vaginally access, the fallopian tube. The present invention proposes to use the hysteroscope's working channel, in certain embodiment of the present invention. Once gynecologists or reproductive endocrinologists own or lease a hysteroscope (and the associated capital equipment), they are free to use the inventive procedures of the present invention using the working channel of the hysteroscope because they are unlimited in terms of which procedures they may conduct using their hysteroscope. It is noteworthy that the working channel of any catheter, which can visualize and gain access to the ostia of the fallopian tubes within the uterus, may be utilized by the present invention.

In preferred embodiments of the present invention, navigating a substantially transparent capsule, which houses a camera portion through the tortuous and narrow fallopian tubes by using a hydraulic propulsion method, has several advantages over navigating a purely catheter-based product through the fallopian tubes. By way of example, hydraulic propulsion overcomes the clinical adverse event of perforation, a drawback of previous direct visualization technologies. In other preferred embodiments of the present invention, hydraulic propulsion avoids perforation as

the device does not depend on the tactile feedback of the fallopian tube. Instead, the hydraulic propellant carries the camera portion through the natural path of the fallopian tube.

In accordance with one embodiment, the present invention provides a hydraulic propulsion device that uses a working channel of a hysteroscope to access the ostia of the fallopian tubes. To this end, Figure 2 shows a hydraulic propulsion device 100 having a handle 5 portion 102, a shaft portion 104, and a seal-creating portion 106. As shown in Figure 2A, which shows a magnified view of a tip of hydraulic propulsion device 100, device 100 includes an imaging subassembly 108 and a capsule 110.

Referring back to Figure 2, handle portion 102 may come equipped with a hydraulic 10 pressure port 112, which is designed to receive a hydraulic propellant (*e.g.*, a saline solution) from a hydraulic propellant reservoir, such as a syringe. Hydraulic pressure port 112 is preferably communicatively coupled to a hydraulic pressure lumen (not shown to simplify illustration) which extends from handle portion 102 through shaft portion 104 to a location near imaging subassembly 108.

Similarly, an electrical wire 118 runs from handle portion 102 through shaft portion 104 15 and is communicatively coupled to imaging subassembly 108. Electrical wire 118 enters a handle portion at an electrical access port 114, which connects to a wire lumen. Electrical wire 118 is placed inside the wire lumen, which also extends from handle portion 102 through shaft portion 104 to a location near image subassembly 108.

A seal-creating port 116 of Figure 2 facilitates a step of creating a seal at an ostia 18 of 20 the fallopian tubes 12 or inside the proximal region of the fallopian tubes. These anatomies are shown in Figure 1. Specifically, seal-creating port 116 of Figure 2 is communicatively coupled to a seal-creating lumen (not shown to simplify illustration), which transports the necessary materials for creating a seal to seal-creating portion 106. In preferred embodiments, seal- 25 creating portion 106 of the present invention is an inflatable body and the seal-creating port 116 is an inflatable port. In these embodiments, the seal-creating lumen is designed to convey air or other gas that inflates the inflatable body and the seal-creating lumen may be referred to as the “inflation lumen.”

In addition to one or more of the ports and lumens described above, handle portion 102 30 preferably includes a housing 120 for holding in place coiled wire 118', and a wire retrieval mechanism 122 to retrieve a hydraulically propelled wire in an operational state of device 100 (which is shown as device 200 in Figure 3). Not all features of housing 120 are shown to simplify illustration and those skilled in the art will recognize that wire retrieval mechanism 122, in a preferred embodiment of the present invention, is akin to a fishing rod, which has a reel 35 mechanism for casting and retrieving a fishing line. In this embodiment, retrieval mechanism

122 includes flexible wire 118 and a reel capable of reeling back the flexible wire from a propelled state. During an operational state of device 100, when the reel is activated, imaging subassembly 108 is retrieved back from a propelled state, preferably into handle portion 102.

In a more preferred embodiment of the present invention, retrieval mechanism 122  
5 includes an electronically activated reel, which electronically activates retrieval of the reel from the propelled state of the reel. In this embodiment, inventive devices include a pressure sensor for conveying a pressure measurement to the electrically activating reel mechanism such that if the pressure exceeds a predetermined value of pressure, then the electrically activating reel mechanism ceases to retrieve imaging subassembly 108. The pressure sensor may be designed to  
10 sense the pressure exerted on imaging subassembly 108, as it is retrieved from the narrow body lumen.

As part of shaft portion 104, seal-creating portion 106 (*e.g.*, inflatable body) is located outside and distal to handle portion 102. In this configuration and when device 100 is in an operational state, imaging portion 108 forms a perfect seal with an inner diameter of the  
15 hydraulic propellant lumen, as shown in Figure 2A. As is explained later in connection with Figure 3, this seal allows for hydraulic propulsion of imaging portion 108. In other preferred embodiments of the present invention, device 100 includes a locking mechanism, which locks imaging portion 108 within the inner diameter of the hydraulic propellant lumen until a requisite pressure is achieved to enable hydraulic propulsion.

20 Image subassembly 108 preferably includes an image sensor and a light source. The image sensor can be any object that is capable of sensing an image. In a preferred embodiment of the present invention, the image sensor includes at least one member selected from a group consisting of a charge coupled device (CCD), a complementary metal oxide semiconductor (CMOS) and an optical fiber. The light source includes a fiber optics light source  
25 or a light emitting diode (“LED”).

In certain embodiments of the present invention, an inflatable object contains the image sensor and the lighting source such that when the inflatable body is inflated, the imaging sensor is positioned near or at an approximate focal length away from the narrow body lumen to allow focused imaging of the narrow body lumen. In this embodiment, the focal length is associated  
30 with the imaging sensor. If the image sensor is a camera, then the focal length referred to herein is that of the camera.

As shown clearly in Figure 2A, capsule 110 protects a portion of imaging subassembly 108. In one embodiment of the present invention, capsule 110 is coated with a lubricant to facilitate hydraulic propulsion or retrieval of the capsule through the narrow body lumen.  
35 Capsule 110 preferably encapsulates a wireless transmitter for wirelessly transmitting images

captured by an imaging sensor of imaging subassembly 108. In certain preferred embodiments, capsule 110 of the present invention encapsulates a pressure sensor, which senses an amount of pressure being applied against the narrow body lumen to determine presence of blockages within the narrow body lumen.

5           Capsule 110 is substantially round and therefore avoids causing tissue trauma, which is a drawback of previously attempted direct visualization devices. Furthermore, capsule 110 has centered within it imaging portion 108. The positioning of imaging portion 108 within capsule 110 overcomes the drawback of the fallopian tube hanging over the distal end of the catheter, preventing an inadequate focal length and therefore unclear picture from being taken.

10           In one embodiment of the present invention, the capsule is designed for encapsulating an inflatable body to enhance buoyancy of a portion of imaging subassembly 108 that is deployed inside the narrow body lumen during hydraulic propulsion. In such embodiments, capsule 110 of the present invention facilitates hydraulic propulsion of the propelled imaging portion as the inflatable body makes the capsule more easier carried by the hydraulic propellant.

15           In certain embodiments of the present invention, capsule 110 encapsulates a microgenerator, which uses the hydraulic propellant to provide power for the light source or the imaging sensor. In this embodiment, the microgenerator of the present invention converts hydraulic energy into electrical energy. This electrical energy is then used to power imaging portion 108 of the device. In other embodiments of the present invention, capsule 110  
20 encapsulates optical fibers, which facilitate imaging by sending imaging signals from within the capsule to the imaging sensor that is located outside capsule 110 and distal to handle portion 102.

          Figure 2B shows a tip of device 100, according to an alternate embodiment of the present invention, where an optical fiber 111 is used for imaging. In this embodiment, optical fiber 111, during an operational state of device 100, conveys the image signals captured to an image sensor  
25 located outside and proximal to shaft 104 of device 100. As standard off the shelf optical fibers may be found having outer diameters of less than .5 mm, the diameter of capsule 110 of this embodiment may be reduced as it does not contain the sensor. As a result, the tip of this embodiment is more easily navigated through the narrow and tortuous path of the fallopian tubes and using optical fiber 111 represents an alternative embodiment of the present invention.

30           Figure 3 shows a portion of device 200 (which is the operational state of device 100), according to one embodiment of the present invention. Device 200 includes a flexible wire 218, a fallopian tube-access device 228, a shaft portion 204, a seal-creating portion 206, an imaging subassembly 208 and capsule 210. Wire 218, shaft portion 204, seal-creating portion 206, imaging subassembly 208 and capsule 210 are substantially similar to their counterparts (*i.e.*,  
35 wire 118, shaft portion 104, seal-creating portion 106, imaging subassembly 108 and capsule

110) shown in Figure 1, except device 200 shows imaging subassembly 208 and capsule 210 being hydraulically propelled during an operational state of device 200. In one preferred embodiment of the present invention, device 200 includes a sail, which surrounds imaging subassembly 208, such that when the imaging subassembly is hydraulically propelled, the sails  
5 expand to enhance the hydraulic propulsion of the imaging subassembly.

Although in connection with Figures 2, 2A, 2B and 3, hydraulic propulsion is described to propel imaging subassembly 108, imaging optical fiber 111 or capsule 110, other preferred embodiments of the present invention contemplate hydraulically propelling therapy into the narrow body lumen. In this embodiment, imaging subassembly 108, imaging optical fiber 111 or  
10 capsule 110 are absent and electrical access port 114 is replaced by a therapy port. Furthermore, the therapy port is communicatively coupled to a therapy lumen, which replaces the wire lumen. Effective therapies contemplated by the present invention are detailed below. In another embodiment of the present invention, an electrical and therapeutic port co-exist to allow direct visualization as the therapy is being administered.

15 To effectively maintain fallopian tubes, the present invention also offers non-hydraulically propelled imaging or therapeutic devices. In certain embodiments of the present invention, a guidewire and/or a catheter, which is positioned over the guidewire, facilitate imaging or therapy. In other embodiments, the guidewire lumen of the present invention facilitates therapeutic intervention.

20 Figure 4A shows two different ovular-shaped protective shields, according to certain embodiments of the present invention, shown as part of a single distal tip 326, which may be designed to function either as a guidewire-based diagnostic imaging device or as a guidewire lumen-based therapeutic intervention device. Figure 4B shows a top view of distal tip 326', which is the same as distal tip 326, except in a different orientation. Two different protective  
25 shields, *i.e.*, a first protective shield 330 and a second protective shield 330', are shown in Figure 4A as being part of single distal tip 326, those skilled in the art will recognize that only one protective shield is necessary in this embodiment of the present invention.

As shown in Figure 4A, distal tip 326 of inventive catheters includes a shaft portion 304, one or more light sources 332, an imaging portion 308 and a guidewire 334. Guidewire 334  
30 guide inventive catheters during an imaging procedure inside the fallopian tubes, for example. According to the present invention, however, guidewire 334 is preferably designed to provide light or is capable of sensing an image. To this end, guidewire 334 may contain illuminating fibers or imaging fibers. If an inventive catheter contains illuminating fibers, then the associated guide wire, which guides that catheter during operation, may include imaging fibers. Alternately,  
35 if the inventive catheter contains imaging fibers, then the associated guidewire 334 may include

illuminating fibers. According to the present invention, in this manner, structures for carrying out illuminating and imaging functions may be distributed between a catheter and its associated guidewire. Separating a light source from an imaging sensor allows a device user to control the amount and angle of light needed to capture a clearer image (akin to a professional photographer  
5 having an external flash).

In certain embodiments of the present invention, guidewire 334 includes optical fibers for providing light to facilitate imaging, and may be made from fiber optics.

In accordance with one embodiment of the present invention, during an operation state  
10 of device with distal tip 326, guidewire 334 extends from a location outside the fallopian tube to another location inside the fallopian, such that light is conveyed from the location outside the fallopian tube to the location inside the fallopian tube. Having the source of the lighting remain outside of the fallopian tube will reduce heat exposure to the fallopian tubes.

In preferred embodiments of the inventive catheters, guidewire 334 includes a plurality of  
15 substantially transparent portions along a length of the guidewire. Each of the plurality of substantially transparent portions allow light to pass through. During an operational state of the catheter, each of the substantially transparent portions illuminate a plurality of different locations along the length of the fallopian tube that are adjacent to the substantially transparent portions. In this embodiment, a light emitting diode ("LED") may be located at or around a guidewire's tip  
20 and, as a result, incident light emanating from the LED exits from the substantially transparent portions and illuminates the tissue.

Inventive catheters may further include an image sensor located at a proximal end of a catheter shaft (*e.g.*, 104 of Figure 2) or inside a handle portion (*e.g.*, 102 of Figure 2) of the catheter. In this configuration of the inventive catheters, the above-mentioned imaging fibers  
25 extend along a length of the catheter shaft such that, during an operational state of the catheter, the imaging fibers facilitate imaging by sending imaging signals from a distal end of the catheter to the imaging sensor. Keeping the sensor outside of the catheter's shaft reduces an outer diameter of the catheter, and therefore, allows the physician to more easily navigate the fallopian tubes and reduces the potential for tissue trauma.

In alternate embodiments of the present invention, the catheters further include an image  
30 sensor for sensing an image. In this embodiment, the image sensor is located at a distal end of a catheter shaft such that, during an operational of the catheter, an image of the fallopian tube sensed by the imaging sensor is conveyed by the imaging fibers or by electrical wires, which extend along a length of the catheter shaft, to a display unit that is located outside the fallopian

tube. Although this configuration may increase the catheter's outer diameter, it provides a clearer image as the sensor is located closer to the image being taken.

Protective shield 330 or 330' of Figure 4A, during an operational state of the device, preferably protect an image sensor and/or imaging fibers and further provide an approximate  
5 focal length (that is associated with the image sensor) between the image sensor and/or the imaging fibers and the fallopian tube to obtain a substantially focused image. Protective shield of the present invention overcomes the drawback of the fallopian tube hanging over the catheter's tip, which makes it hard to capture a clear image.

In other preferred embodiments, inventive catheters include a light source (*e.g.*, light  
10 source 332 shown in Figure 4A) that is located at a distal end of a catheter shaft such that a substantially transparent protective shield (*e.g.*, protective shield 330 or 330' of Figure 4A) protects the image sensor and/or the imaging fibers, and the light source is located outside the protective shield as shown in Figure 4A. This embodiment prevents illumination of the fallopian tube to be distorted by the presence of the substantially transparent protective shield.

The present invention recognizes that during an imaging operation, fallopian tube tissue  
15 might fold over a light source and block illumination, and thereby, prevent proper illumination of a target location. In alternate preferred embodiments, inventive catheters include a light source that is protected by the substantially transparent protective shield. In this embodiment, the presence of a protective shield, prevents the fallopian tube tissue from folding over and blocking  
20 the light source.

To reduce the risk of perforating the fallopian tube during an imaging operation as  
encountered by certain imaging attempts discussed above, inventive catheters preferably include a pressure sensor. In one implementation of this embodiment, the pressure sensor is located at a  
25 distal end of the guidewire and/or the catheter. During an imaging operation, the pressure sensor is capable of measuring a value of pressure exerted by the guidewire and/or the catheter against the fallopian tube. The pressure sensor may be communicatively coupled to a processor that provides an alert signal during an imaging operation. If, during an imaging operation, the value of pressure exerted by the guidewire and/or the catheter inside the fallopian tube is equal to or exceeds a predetermined unacceptable value of pressure, the pressure may provide the alert  
30 signal to a catheter's user (*e.g.*, activating a red warning light on the handle).

Inventive catheters may further include a guidewire lumen having defined therein a  
channel for the guidewire (*e.g.*, guidewire 334 of Figure 4A). During an operational state of the catheter, and in absence of the guidewire inside the guidewire lumen (*e.g.*, when an imaging  
operation has concluded), the channel inside the guidewire lumen is capable of transporting  
35 therapy to the fallopian tube.

The therapy includes at least one member selected from a group consisting of an anti-inflammatory agent, bio-absorbable stent and a drug-coated inflatable body. In certain embodiments of the present invention, a liquid anti-inflammatory agent is delivered locally to a diseased site. Inflammation (likely caused by infection) is thought to be the leading cause of fallopian tube occlusion.

In those embodiments of the present invention where therapy includes a bio-absorbable stent, the stent provides to the fallopian tubes both mechanical support and a drug, which treats a local disease and prevents the occlusion from recurring. After the stent is absorbed by the body and the disease is treated, the egg, may uninterruptedly pass from the ovaries through the fallopian tube to the uterus.

With respect to the drug-coated inflatable body, during an operational state of the catheter, when the inflatable body (such as a balloon) is expanded, debris found within the fallopian tube may be dislodged by the force it takes to expand the balloon. Furthermore, the inflatable body may be positioned within a partial blockage. In this case, the expansion force will apply sufficient mechanical force to a blockage and serves to clear the blockage.

Furthermore, the drug-coating on the inflatable body (*e.g.*, anti-inflammatory agent) prevents recurrence of those blockages for a time adequate to allow for conception. On the other hand, drug coated balloons used to treat coronary artery disease, face the challenge of a continuous blood flow which eventually rids the artery of the drug. Consequently, the patient only temporarily sees the benefit of the therapy, where treatment of coronary artery disease needs to last a lifespan of a patient. In contrast, the fallopian tubes are not inherently fluid filled. Therefore, the drug will last longer in the diseased region of the fallopian tube. Furthermore, the impact of the drug need only last for as long as it takes the patient to conceive (on average 0 to 12 months). If the drug dissipates and blockages do occur at some point after conception, those blockages do not cause any pain or discomfort to the patient.

Figure 5A shows a conical-shaped distal tip 426, according to one embodiment of the present invention. The conical-shaped distal tip 426 is preferably part of a guidewire-based diagnostic imaging device or in a guidewire lumen-based therapeutic intervention device. Regardless of the manner in which distal tip 426 is implemented, it includes a shaft portion 404, one or more light sources 432 (labeled in Figure 5B), an imaging portion 408, a protective shield 430 and guidewire 434, all of which are substantially similar to their counterparts shown in Figure 4A (*i.e.*, shaft portion 304, one or more light sources 332, imaging portion 308, protective shield 330 and guidewire 334, respectively), except Figure 5A shows an conical-shaped distal tip provides the image sensor a different focal length than that provided by the ovular-shaped distal tip of Figure 4A, and protective shield 430 has defined therein an ingress aperture 436 and an

egress aperture 438. During an imaging operation, guidewire 434, which is positioned outside protective shield 430, is capable of entering through ingress aperture 436 and exiting from egress aperture 438. In other words, apertures 436 and 438 allow guidewire 434 to pass through protective shield 430 and access a location in the fallopian tubes that is distal to protective shield  
5 430. This will allow the physician to push away from the fallopian tube wall using the guidewire if additional distance is needed in order to capture a clear image.

Furthermore, the conical shape may introduce less tissue trauma than the ovular-shaped protective shield. Figure 5B is a top view of a distal tip 426', which is the same as distal tip 426 shown in Figure 5A, except distal tip 426' has a different orientation than distal tip 426.

10 Preferred embodiments of the present invention also provide non-guidewire based diagnostic imaging device or a non-guidewire lumen-based therapeutic intervention device. A non-guidewire based diagnostic imaging device includes a sensing lumen, a solution lumen and optionally a therapeutic lumen. The sensing lumen, in turn, includes a sensing portion and an inflatable portion. The sensing portion is capable of sensing information (*e.g.*, imaging  
15 information) about the fallopian tube.

The solution lumen is designed to provide a solution, which facilitates sensing carried out by the sensing portion. The solution is also designed to flush the fallopian tube, ridding it of residual blood and mucous, which obscures the image. Furthermore, presence of the solution facilitates in the expansion of the fallopian tube and thereby reduces the chance of causing a  
20 perforation. Finally, therapeutic solutions used in the therapeutic are discussed above in greater detail.

During an operational state of the non-guidewire based diagnostic device, the inflatable portion inflates to create a space around the sensing portion such that in presence of the solution, the sensing portion senses information regarding the fallopian tube, including but not limited to  
25 the presence of sterilization implants and naturally occurring blockages. This space allows for there to be an adequate focal length between the sensing portion and the fallopian tube wall to facilitate capturing a clear image (*e.g.*, a clear image may be taken if the sensing portion is a standard optical camera or light-wave scattering optical system). However, if the sensing portion consists of a sound-wave imaging system, then the inflatable portion creates a seal so that the  
30 fallopian tube may be filled with a liquid medium, through which sound waves can propagate.

The sensing portion may include at least one member selected from a group consisting of light source, a camera, an acoustic imaging system and a scattered-light imaging system. Certain current techniques used for cardiovascular imaging (*e.g.*, intravascular ultrasound (“IVUS”) and optical coherence tomography (“OCT”)) utilize light scattering and acoustic imaging techniques,  
35 but do not lend themselves to imaging fallopian tubes because of their rigidity. Furthermore,

current cardiovascular IVUS catheters are not capable of creating a seal to facilitate imaging of a structure which is inherently non-fluid filled because in the absence of a medium, sound waves do not travel. It is noteworthy that because the fallopian tube is non-fluid filled, a seal must be created and the fallopian tube must be filled with a liquid medium, such as saline, before  
5 imaging using sound waves can occur. Further still, these catheters have relatively large dimensions which make it difficult to access the length of the narrow and tortuous fallopian tube.

To this end, the present invention proposes that catheter designs of IVUS and OCT may be modified in a manner consistent with the different relevant inventive catheters. Inventive catheters described herein are not limited to IVUS and OCT applications, and work well with  
10 other optical imaging techniques (*e.g.*, imaging carried out by complementary metal oxide semiconductor (“CMOS”) or optical fiber). In accordance with preferred embodiments, inventive catheters include unique atraumatic tips and/or inflatable bodies as described below.

The imaging information collected by image portion 508 provides such information about the fallopian tube as naturally occurring blockage, inflammation, hydrosalpinx, sterilization  
15 implants operatively placed in the fallopian tubes and disease of the fallopian tube. This information is particularly valuable in diagnosing fallopian tube disorder and allows for disease-specific therapeutic intervention, if needed.

Figure 6A shows a non-guidewire based diagnostic device where the sensing portion senses image information about the fallopian tube, allowing the physician to diagnose disease.  
20 Specifically, Figure 6A is a side view of a non-inflated conical-shaped distal tip 526, according to one embodiment of the present invention that is preferably used in a non-guidewire-based diagnostic imaging device or in a non-guidewire lumen-based therapeutic intervention device. Distal tip 526 includes an imaging portion 508, an inflatable portion 506 and a shaft portion 504. Imaging portion 508 and shaft portion 504 are substantially similar to their counterparts in  
25 Figure 5A (*i.e.*, imaging portion 408 and shaft portion 404), except shaft portion 404 of Figure 5A contains a guidewire 434.

In accordance with one preferred embodiment, inventive distal tips include a pressure sensor located at a distal end of a catheter and are designed to measure a value of pressure exerted by the catheter during an operational state of the device. The pressure sensor features  
30 described above to alert a user of undue excessive pressure may also be incorporated in this embodiment.

Figure 6B is a side view of the conical-shaped distal tip of Figure 6A in its inflated state. Inflatable portion 506, in its inflated state (*i.e.*, inflated portion 506' of Figure 6B) has an atraumatic shape, which is one shape selected from a group consisting of conical, ovular and  
35 dome.

Figure 7A is a side view of another non-inflated ovular-shaped distal tip 626, according to one embodiment of the present invention, also preferably used in a non-guidewire-based diagnostic imaging device or in a non-guidewire lumen-based therapeutic intervention device. Distal tip 626 is substantially similar to distal tip 526 of Figure 6A (*i.e.*, imaging portion 608 and shaft portion 604 are substantially similar to imaging portion 508 and shaft portion 504 of Figure 6A), except inflatable portion 606 of Figure 7A has a different shape than inflatable portion 506 of Figure 6A. The differences in shape between inflatable portions 506 and 606 are evident in their respective inflatable states and may correspond to different focal lengths and different amounts of tissue trauma. Figure 7B is a side view of ovular-shaped distal tip 626', which is in an inflated state of distal tip 626 of Figure 7A.

Figure 8A is a side view of a non-inflated dome-shaped distal tip 726, according to one embodiment of the present invention, preferably used in a non-guidewire-based diagnostic imaging device or in a non-guidewire lumen-based therapeutic intervention device. Distal tip 726 is substantially similar to distal tip 526 of Figure 6A (*i.e.*, imaging portion 708 and shaft portion 704 are substantially similar to imaging portion 508 and shaft portion 504 of Figure 6A), except inflatable portion 706 of Figure 8A has a different shape than inflatable portion 806 of Figure 6A. Like the differences between inflatable portions 506 and 606, the differences in shape among inflatable portions 506, 606 and 706 are evident in their respective inflatable states. Figure 8B is a side view of ovular-shaped distal tip 726', which is in an inflated state of distal tip 726 of Figure 7A.

Figure 8C shows certain major components, according to one embodiment of the present invention, in an inflated distal tip 826, which is substantially similar to inflated distal tip 726' of Figure 8B. Figure 8C shows a more detailed structure that is preferably contained within inflatable portion 806. According to this figure, inflatable portion 806 includes an inflatable component 806A and a non-inflatable component 806B. During an operational state of the device, the inflatable component 806A inflates, while non-inflatable component 806B does not inflate, but serves to provide mechanical support to inflatable portion 806.

Figure 9 shows a process flow diagram 900, according to one embodiment of the present invention that uses a hydraulic propulsion mechanism for diagnostic imaging. Preferably process 900 begins in step 902, which involves establishing a channel from outside a narrow body lumen to a proximal region of the narrow body lumen or a region that is proximate to the narrow body lumen. By way of example, a hysteroscope is used to visualize and gain access to the ostia of the fallopian tubes within uterus. In this case, the working channel of the hysteroscope establishes the channel of step 902 from outside the fallopian tube to the ostia of the fallopian tube within uterus.

Next, step 904 of Figure 9 includes placing an imaging device or a therapeutic device through the channel. Continuing with the above example of the hysteroscope, step 904 is carried out by introducing shaft portion 104 of device 100 of Figure 2 through the working channel of the hysteroscope until the distal end of shaft portion 104 is slightly distal to the distal end of the hysteroscope's working channel or until the distal end of shaft portion 104 is located in the approximate region of the fallopian tube.

In this configuration, step 906 of Figure 9 is carried out. Step 906 includes creating a seal in or outside the narrow body lumen such that in presence of a hydraulic propellant the narrow body lumen is pressurized to allow diagnostic imaging or therapeutic treatment of the narrow body lumen. In order to create a seal in the fallopian tube, for example, the seal-creating portion 106 of Figure 2 may be expanded either proximal to the fallopian tube ostia in the uterus or within the proximal region of the fallopian tube. The seal will allow pressure to build the portion of the device which is meant to be hydraulically propelled.

Then, another step 908 of Figure 9 includes hydraulically propelling, using the hydraulic propellant, the imaging portion (108 of Figure 2A) or the therapeutic device contained in the capsule (110 of Figure 2A) through the narrow body lumen. By way of example, device 200 of Figure 3 shows a capsule 210, which is attached to handle portion 102 of Figure 2 by a wire 218 of Figure 3, being hydraulically propelled. Several steps may be taken to aid in the propulsion of the capsule (*e.g.*, capsule 210 of Figure 3). The capsule, which may be made from a substantially transparent material, is preferably inflated. Alternately, the capsule may contain an inflatable body, such as a balloon, which is preferably inflated. These steps enhance the buoyancy of the capsule, aiding the propulsion of the capsule. Furthermore, in its propelled state, sails 238 of Figure 3 attached to imaging subassembly 208 will deploy to capture the hydraulic propellant (which is akin to sails on a sail boat that capture the power of wind to propel the boat's forward movement).

After step 908 and once a diseased portion of the fallopian tube or the fimbria of the fallopian tube is reached, step 910 of Figure 9 includes treating or imaging the narrow body lumen. As discussed above in reference to Figures 2, 2A, 2B and 3 imaging is carried out by imaging subassembly 108 of Figure 2A. Imaging, according to certain embodiments of inventive step 908, is carried out in an antegrade fashion (during forward propulsion of imaging subassembly 108) or retrograde fashion (during retrieval of imaging subassembly 108). With respect to treating the narrow body lumen, once the disease state is imaged, one therapy selected from a group consisting of flushing saline to rid the fallopian tube of debris, applying anti-inflammatory agent in liquid form and applying mechanical force to an occlusion using an inflatable body (*e.g.*, seal-creating portion 104 of Figure 2), is preferably carried out.

Process 900 preferably comes to an end in step 912 of Figure 9, which involves retrieving the imaging device from the narrow body lumen. By way of example, retrieval mechanism 122 of Figure 2 is activated to retrieve the imaging device from the fallopian tube. The retrieval mechanism is preferably activated by engaging a reel mechanism (*e.g.*, mechanism 122 of Figure 2), which is placed on the handle. Alternately, the entire device may be pulled back towards the user to remove it from the narrow body lumen.

It is noteworthy that steps 902 and 904 of Figure 9 are optional and that the steps mentioned above need not be carried out in any particular order. Rather the sequence of steps described above represent a more preferred embodiment of the present invention. Process 900 can be carried out using any structure and is not limited to any structure shown in Figures 2, 2A, 2B and 3. The structures shown in these figures serve as examples and are used to facilitate discussion regarding process 900.

Figure 10 shows a process flow diagram 1000, according to one embodiment of the present invention that uses a guidewire mechanism for diagnostic imaging. Preferably process 1000 begins in step 1002, which involves establishing a channel from outside a female anatomy to a proximal region of a fallopian tube or a fallopian tube ostia within uterus. Step 1002 is substantially similar to the imaging aspect of step 902 of Figure 9.

Next, step 1004 includes steering a guidewire through the channel to a target location within a lumen of a fallopian tube and the guidewire capable of providing light or imaging. By way of example, guidewire 334 in Figure 4A is bundle of optical fiber capable of providing light or imaging a fallopian tube.

In this configuration, step 1006 is carried out. Step 1006 includes placing a catheter, which facilitates imaging or therapy, over the guide wire. Depending on whether guidewire 334 of Figure 4A is capable of imaging or illuminating, the catheter contains the complementary structure to facilitate imaging.

Then, another step 1008 includes imaging the fallopian tube using the guidewire and the catheter. By way of example, imaging as required by this step is carried out by positioning guidewire 334 of Figure 4A relative to the catheter (*e.g.*, catheter 304 of Figure 4A) so that the correct amount and angle of light illuminates the portion of fallopian tube being imaged. Furthermore, a protective shield (*e.g.*, shield 330 of Figure 4A) is positioned so that the appropriate focal length is achieved between the fallopian tube wall and the imaging portion (*e.g.*, imaging portion 308 of Figure 4A).

After step 1008, step 1010 includes removing the guidewire from the channel. Continuing with the guidewire example of Figure 4A, guidewire 344 is removed from the

hysteroscope's working channel referenced in step 1002 of Figure 10. This allows the guidewire channel to be used for delivery of therapy.

5 Next step 1012 includes introducing regional therapy to the fallopian tube through the channel. Therapy in this step is preferably introduced by way of an additional therapeutic catheter or in liquid form through the guidewire channel discussed above.

10 Process 1000 preferably comes to an end in step 1014, which involves treating the fallopian tube using the regional therapy or the catheter. Therapy in this step is preferably one therapeutic solution selected from a group consisting of applying an anti-inflammatory agent in liquid form, introducing a drug-coated balloon (*e.g.*, coated with an anti-inflammatory), introducing a bio-absorbable stent and flushing with saline to remove debris from the fallopian tube.

15 It is noteworthy that steps 1002, 1010, 1012 and 1014 are optional and that the steps mentioned above need not be carried out in any particular order. Rather the sequence of steps described above represent a more preferred embodiment of the present invention. In one preferred embodiment of the present invention, another step may be added. Specifically, after imaging has concluded at the end of step 1008, another step, which includes retrieving the catheter from the fallopian tube is more preferably carried out. Process 900 can be carried out using any structure and is not limited to any structure shown in Figures 4A, 4B, 5A and 5B. The structures shown in these figures serve as examples and are used to facilitate discussion  
20 regarding process 1000.

Although illustrative embodiments of this invention have been shown and described, other modifications, changes, and substitutions are intended. By way of example, the present invention discloses fallopian tubes as an exemplar of a narrow body lumen, which may undergo maintenance, and other anatomical structures, such as coronary arteries, may be similarly  
25 maintained. Accordingly, it is appropriate that the appended claims be construed broadly and in a manner consistent with the scope of the disclosure, as set forth in the following claims.

## CLAIMS

1. A device for maintaining a narrow body lumen, comprising:  
a hydraulic propulsion mechanism and at least one of an imaging portion or a therapeutic portion, said hydraulic propulsion mechanism configured for propelling said imaging portion or said therapeutic portion relative to said hydraulic propulsion mechanism and through the narrow body lumen, said hydraulic propulsion mechanism including a shaft portion, wherein the narrow body lumen is distal of a distal end of said shaft portion;  
wherein said imaging portion or said therapeutic portion, when propelled by said hydraulic propulsion mechanism, is driven distally from said distal end of said shaft portion and is distally spaced therefrom; and  
a retrieval mechanism for retrieving said imaging portion or said therapeutic portion from said narrow body lumen.
2. The device of claim 1, further comprising a handle portion, which receives one or more luers, one of which is designed to provide hydraulic pressure through said shaft portion to hydraulically propel said imaging portion or said therapeutic portion through said narrow body lumen.
3. The device of claim 2, further comprising an inflation luer, which is received by said handle portion and is designed to inflate an inflatable body and create a seal to facilitate imaging and therapeutic treatment.
4. The device of any of claims 1-3, wherein said hydraulic propulsion mechanism includes:  
a luer designed to receive a hydraulic propellant; and  
a hydraulic propellant lumen that is communicatively coupled to said luer and, using said hydraulic propellant, is capable of hydraulically propelling said imaging portion or said therapeutic portion.
5. The device of claim 4, wherein said imaging portion or said therapeutic portion, during an operational state of said device, forms a seal with the inner diameter of said hydraulic propellant lumen to allow for hydraulic propulsion of said imaging device or said therapeutic device.

6. The device of claim 4 or 5, further comprising a locking mechanism, which locks said imaging portion or said therapeutic portion within said inner diameter of said hydraulic propellant lumen until a requisite pressure is achieved to enable hydraulic propulsion.
7. The device of any one of claims 1-6, further comprising a sail which surrounds said imaging portion or said therapeutic portion such that when said imaging portion or said therapeutic portion is hydraulically propelled, said sail expands to enhance the hydraulic propulsion of said imaging portion or said therapeutic portion.
8. The device of any one of claims 1-7, wherein said device comprises said imaging portion and said imaging portion includes at least one member selected from a group consisting of an image sensor and a light source, said imaging portion further including a capsule, wherein said capsule is made from a substantially transparent material, ensures a focal length from a subject being imaged by said imaging portion and encapsulates said at least one member.
9. The device of claim 8, wherein said image sensor includes at least one member selected from a group consisting of a charge coupled device (CCD), a complementary metal oxide semiconductor (CMOS) and an optical fiber.
10. The device of claim 8 or 9, wherein said capsule comprises an inflatable body to enhance buoyancy of said imaging portion or said therapeutic portion and facilitate hydraulic propulsion of said imaging portion or said therapeutic portion.
11. The device of any one of claims 8-10, wherein said capsule comprises an inflatable body, wherein said inflatable body contains said image sensor and said light source such that when said inflatable body is inflated, said imaging portion is positioned near or at an approximate focal length away from said narrow body lumen to allow focused imaging of said narrow body lumen, wherein said approximate focal length is associated with said image sensor.
12. The device of any one of claims 8-11, wherein said capsule encapsulates a microgenerator which uses a hydraulic propellant to provide power for at least one of said light source, said imaging sensor and said therapeutic portion, and wherein said microgenerator converts hydraulic energy into electrical energy.

13. The device of any one of claims 8-10, wherein said capsule encapsulates optical fibers which facilitate imaging by sending imaging signals from within said capsule to said imaging sensor that is located outside said capsule and distal to a handle portion of said device, said device further comprising a flexible wire communicatively coupled to said imaging portion or said therapeutic portion-such that said imaging portion or said therapeutic portion is hydraulically propelled through a tortuous pathway inside said narrow body lumen.
14. The device of any one of claims 8-13, further comprising:  
a pressure sensor;  
a pressure indicator; and  
wherein said pressure sensor is designed to measure pressure being applied against said narrow body lumen and to convey a measurement of pressure to said pressure indicator, and if said measurement of pressure equals or exceeds a predetermined value of pressure, then said pressure indicator transmits an alert signal.
15. The device of any one of claims 1-14, wherein said retrieval mechanism includes:  
a flexible wire communicatively coupled to said imaging portion or said therapeutic portion;  
a reel capable of reeling back said flexible wire from a propelled state; and  
wherein when said reel is activated, said imaging portion or said therapeutic portion are retrieved from a propelled state of said imaging portion or said therapeutic portion.
16. The device of claim any one of claims 1-13 and 15, further comprising a pressure sensor, which senses pressure on said imaging portion or said therapeutic portion, as they are retrieved from said narrow body lumen.
17. A process of maintaining a narrow body lumen, said process comprising:  
creating a seal inside or outside said narrow body lumen such that in presence of a hydraulic propellant, said narrow body lumen is pressurized to allow diagnostic imaging of said narrow body lumen using an imaging portion of an imaging device;  
hydraulically propelling, using said hydraulic propellant, said imaging portion distally of a main body of a device and a location of said seal through said narrow body lumen;  
imaging said narrow body lumen; and  
retrieving said imaging portion from said narrow body lumen.

18. The process of claim 17, wherein said creating a seal inside or outside said narrow body lumen includes at least one of:

- (a) creating a seal at an ostium of a fallopian tube within a uterus;
- (b) providing an inflatable body at a proximal region of said narrow body lumen or at a region that is proximate to said narrow body lumen; and  
inflating said inflatable body to create a seal;
- (c) obtaining a hydraulic propellant lumen designed to transport said hydraulic propellant; and  
creating a seal between an outer diameter of said imaging device and an inner diameter of said hydraulic propellant lumen; and/or
- (d) obtaining a hydraulic propellant lumen for holding said hydraulic propellant; and  
locking said imaging portion within an inner diameter of said hydraulic propellant lumen.

19. The process of claim 17 or 18, wherein said hydraulically propelling includes at least one of:

- (a) introducing a hydraulic propellant through a hydraulic propellant lumen to generate hydraulic pressure;
- (b) obtaining a sail, which surrounds said imaging portion; and  
expanding said sail to enhance hydraulic propulsion of said imaging portion;
- (c) coating a capsule or said imaging portion with lubricant, and said capsule encapsulates said imaging portion;
- (d) sensing a value of pressure exerted on said narrow body lumen by said imaging portion or a capsule encapsulating said imaging portion;
- (e) inflating an inflatable body to facilitate hydraulic propulsion of an imaging portion or a capsule encapsulating said imaging portion, and said capsule is not the same as said inflatable body; and/or
- (f) inflating an inflatable capsule containing said imaging portion.

20. The process of any one of claims 17-19, wherein said retrieving includes at least one of:

- (a) reeling a flexible wire, which is communicatively coupled with said imaging portion, from a propelled state of said flexible wire;
- (b) sensing a value of pressure exerted by an imaging portion or a capsule encapsulating said imaging portion; and

retrieving said imaging portion or said capsule if said value of pressure equal or exceeds a predetermined unacceptable value of pressure; and/or

- (c) activating a manual or an electronic retrieval system.

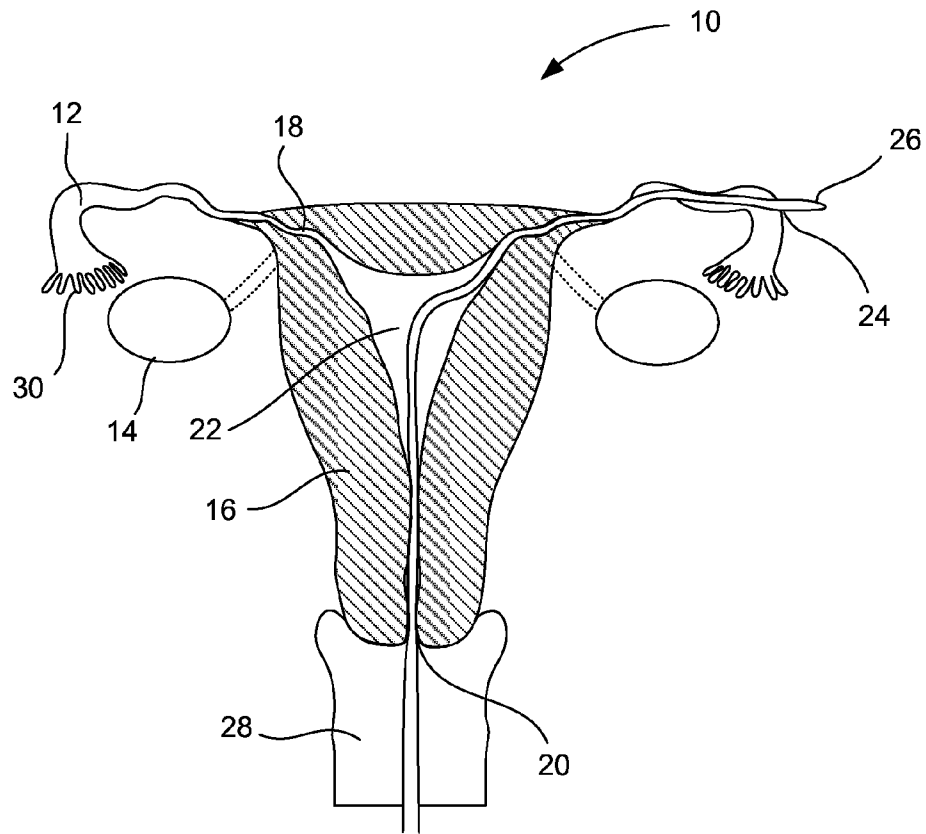
**NVision Medical Corporation**

**Patent Attorneys for the Applicant/Nominated Person**

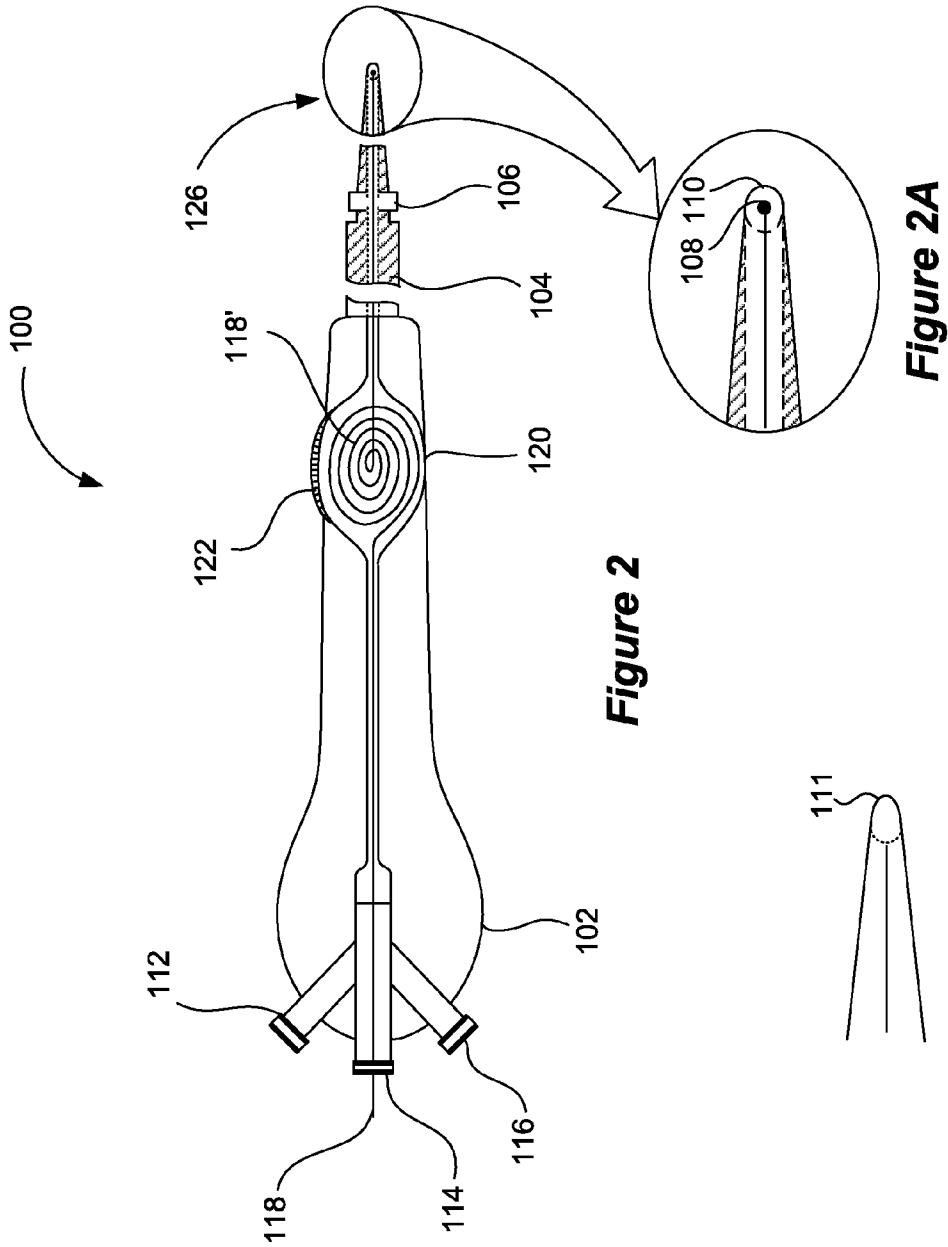
**SPRUSON & FERGUSON**

2012209090 23 Feb 2016

1/10

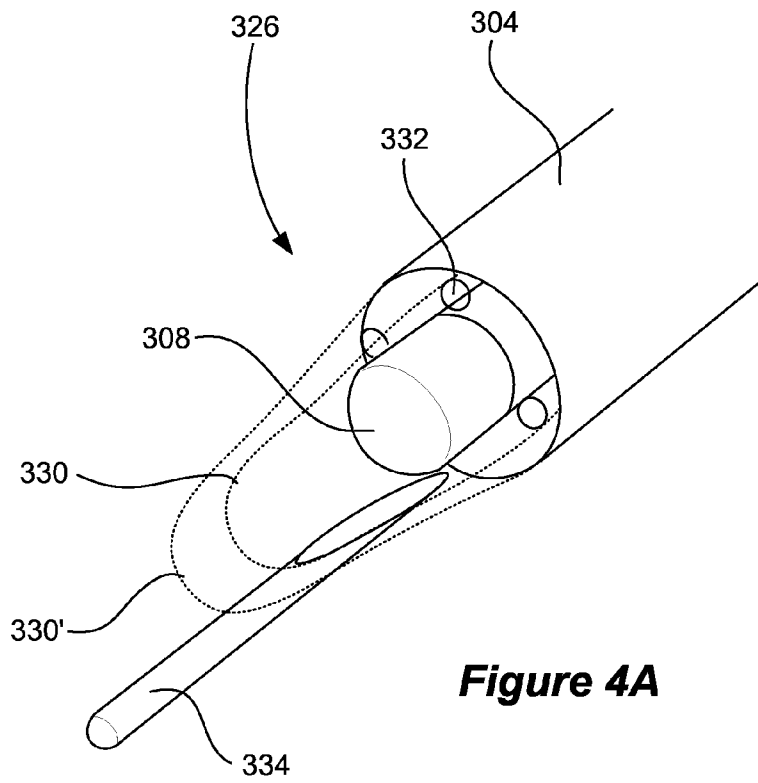


**Figure 1**

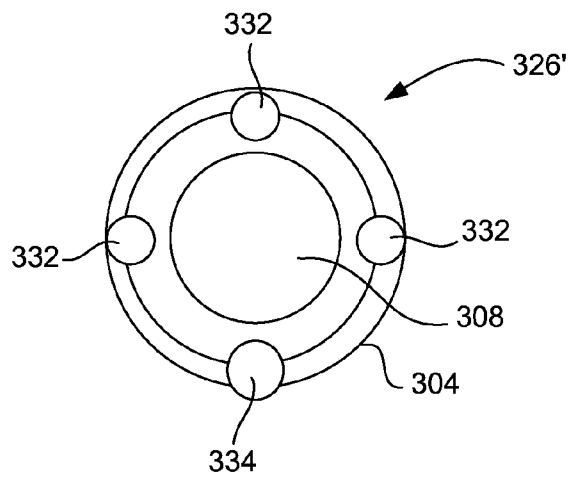




4/10

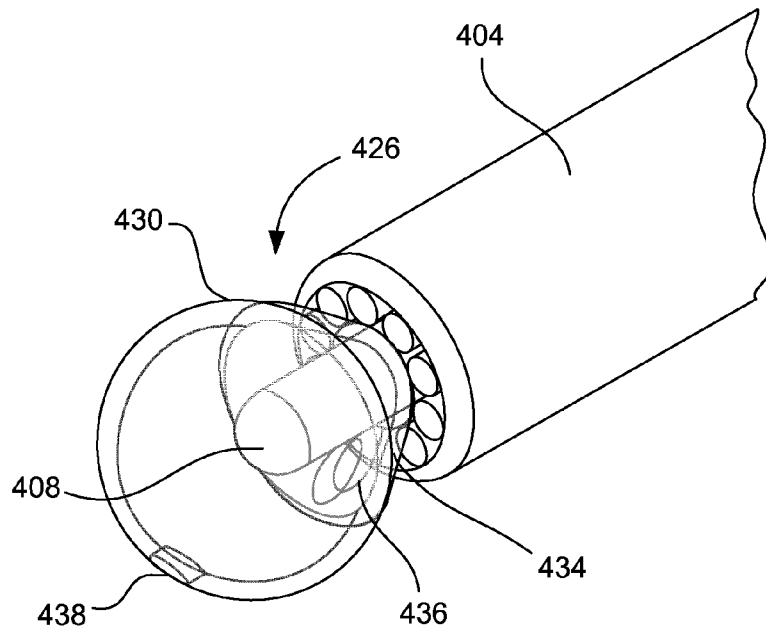


**Figure 4A**

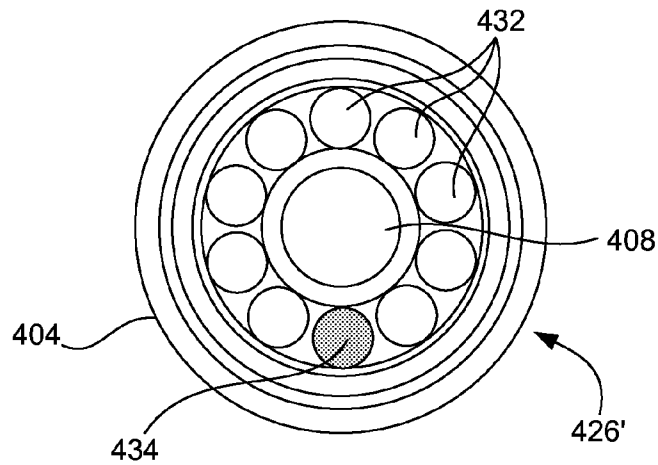


**Figure 4B**

5/10

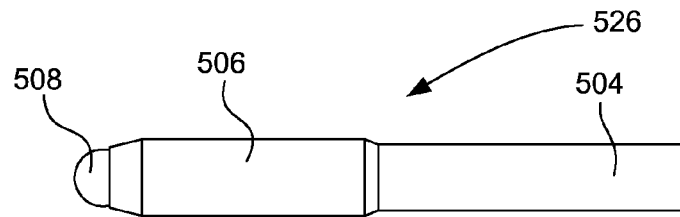


**Figure 5A**

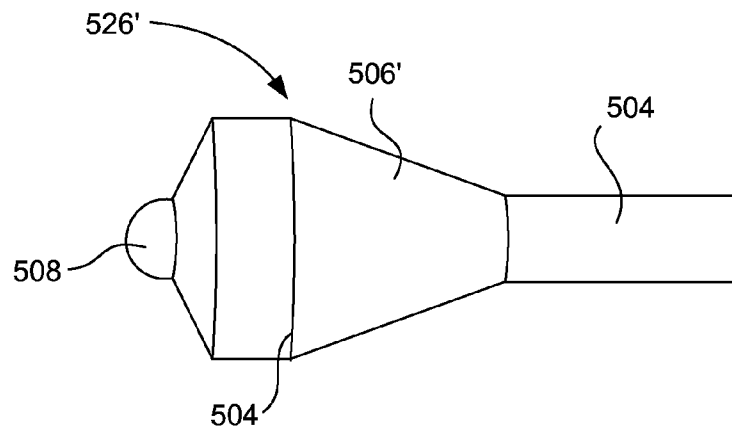


**Figure 5B**

6/10

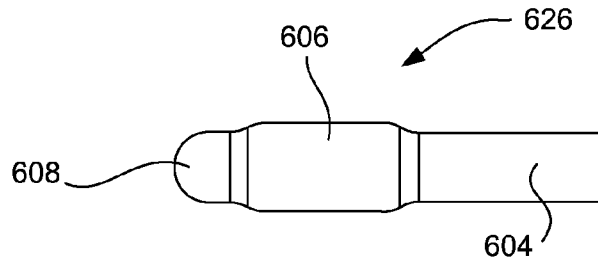


**Figure 6A**

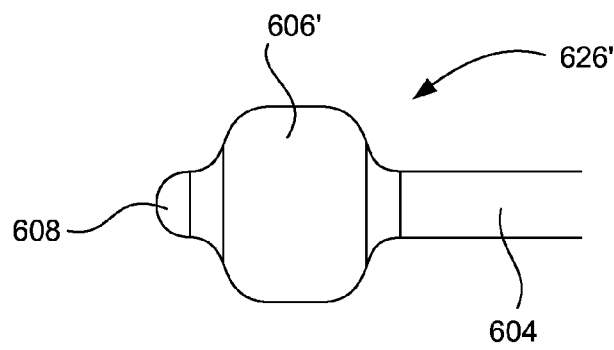


**Figure 6B**

7/10

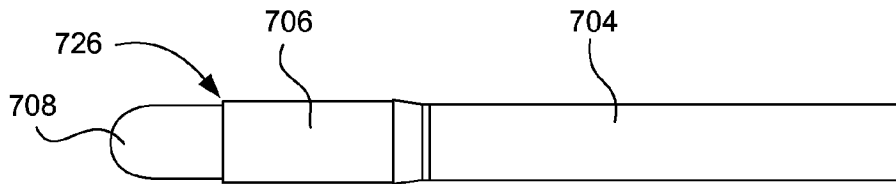


**Figure 7A**

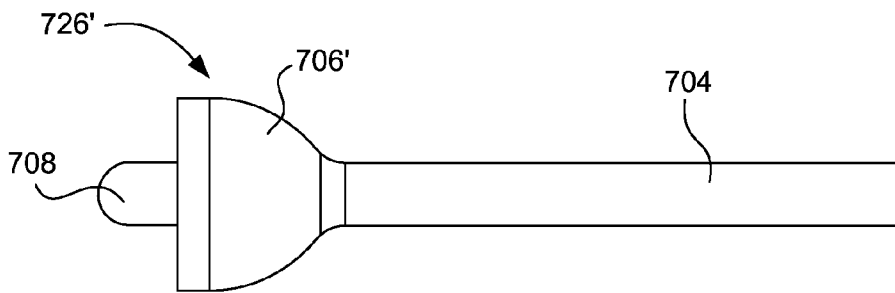


**Figure 7B**

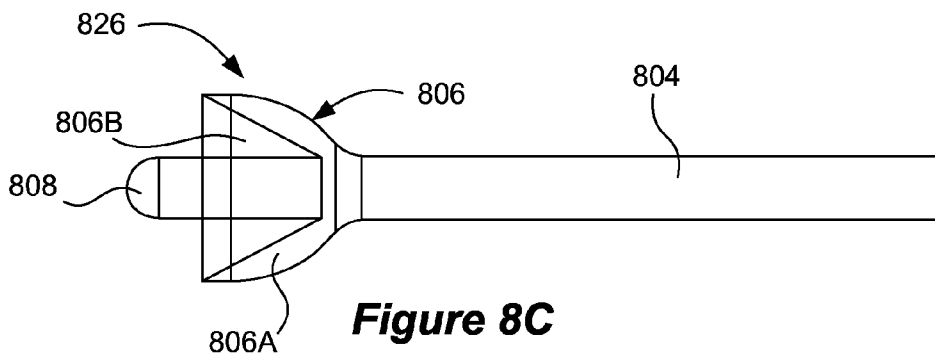
8/10



**Figure 8A**

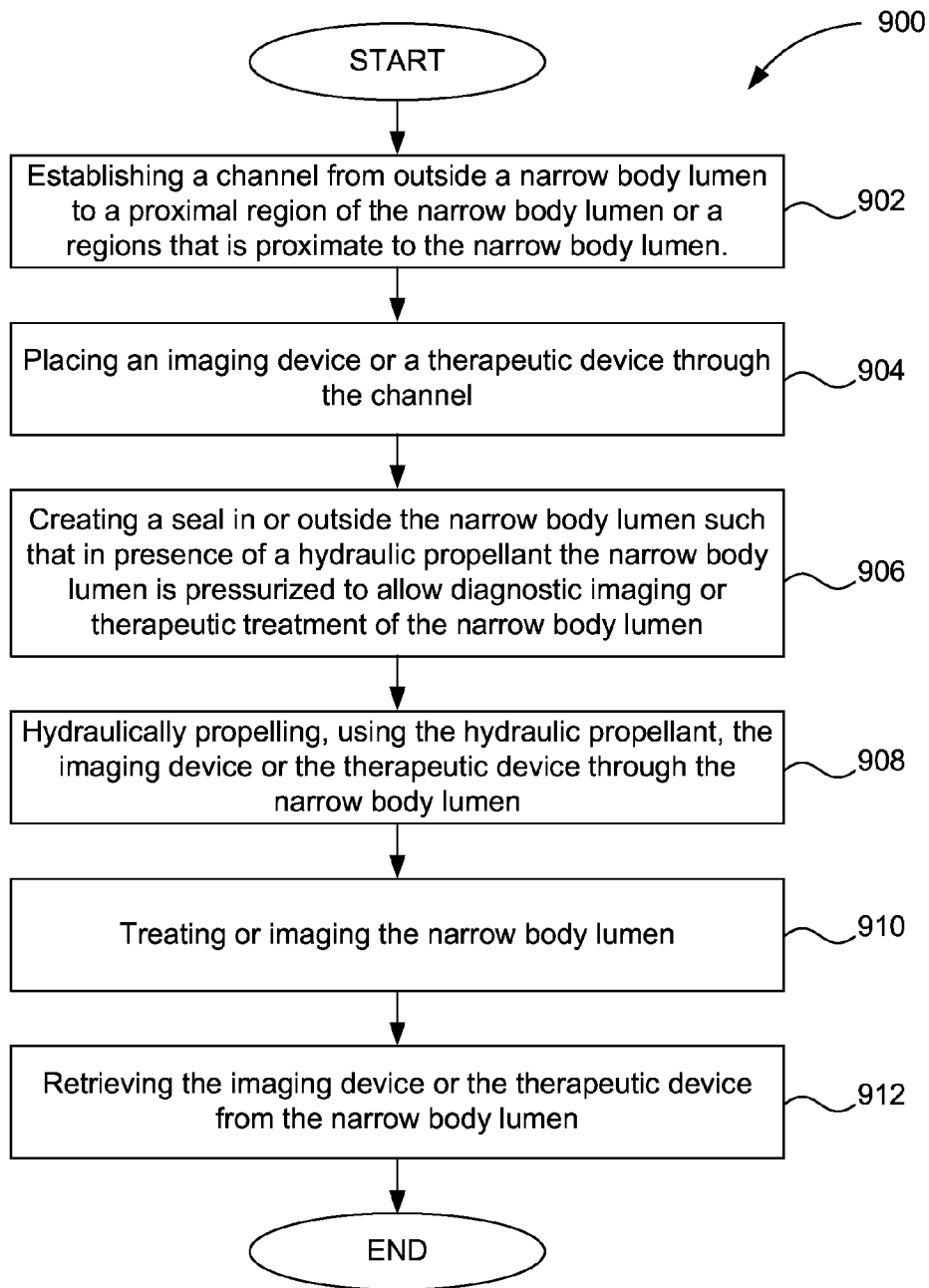


**Figure 8B**

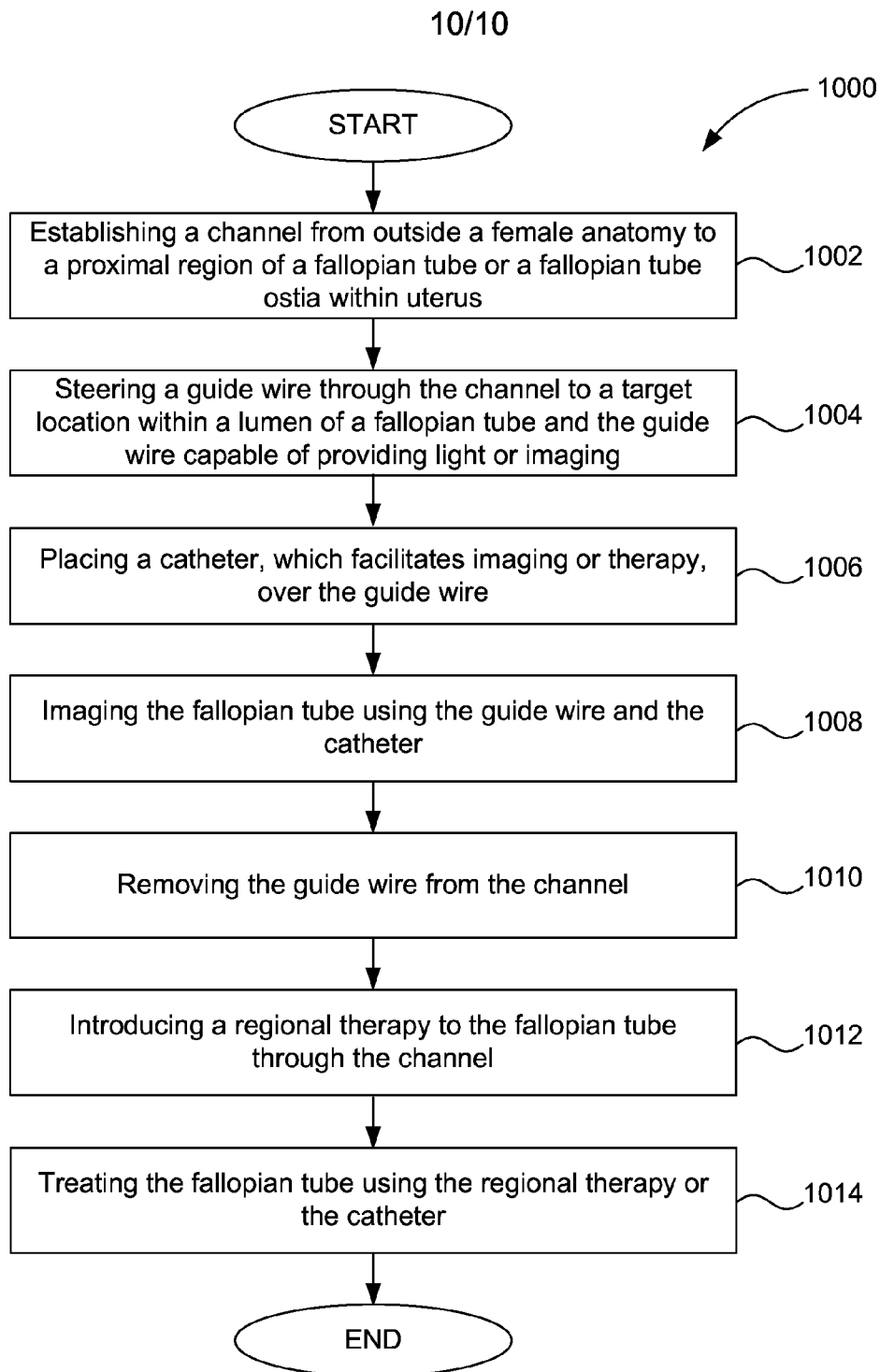


**Figure 8C**

9/10



**Figure 9**



**Figure 10**