

DANIEL MILLS.

Machine for Sewing Boots and Shoes.

No. 127,423.

Fig. 1

Patented June 4, 1872.

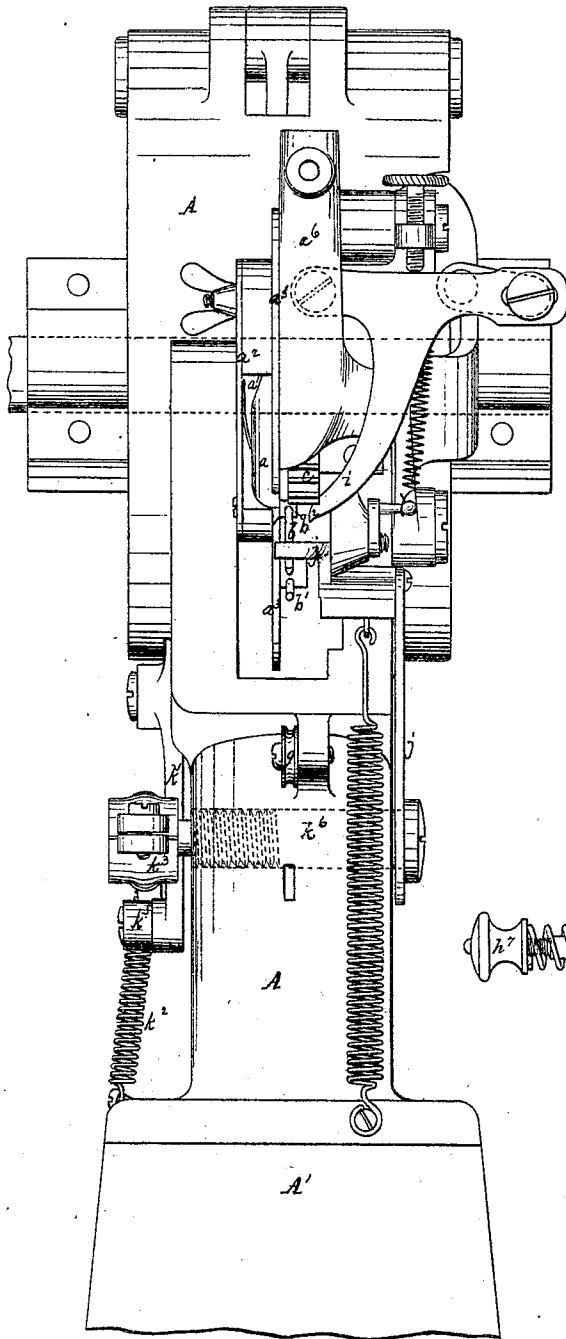
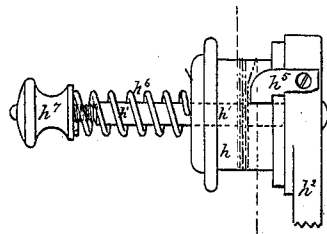

Fig. 4.



Witnesses.

L. B. Nottingham.

Thomas C. Smith

*(Signature)*

Inventor.

Daniel Mills

by A. Pollok

*(Signature)*

DANIEL MILLS.  
Machine for Sewing Boots and Shoes.  
No. 127,423. Patented June 4, 1872.

Fig. 2.

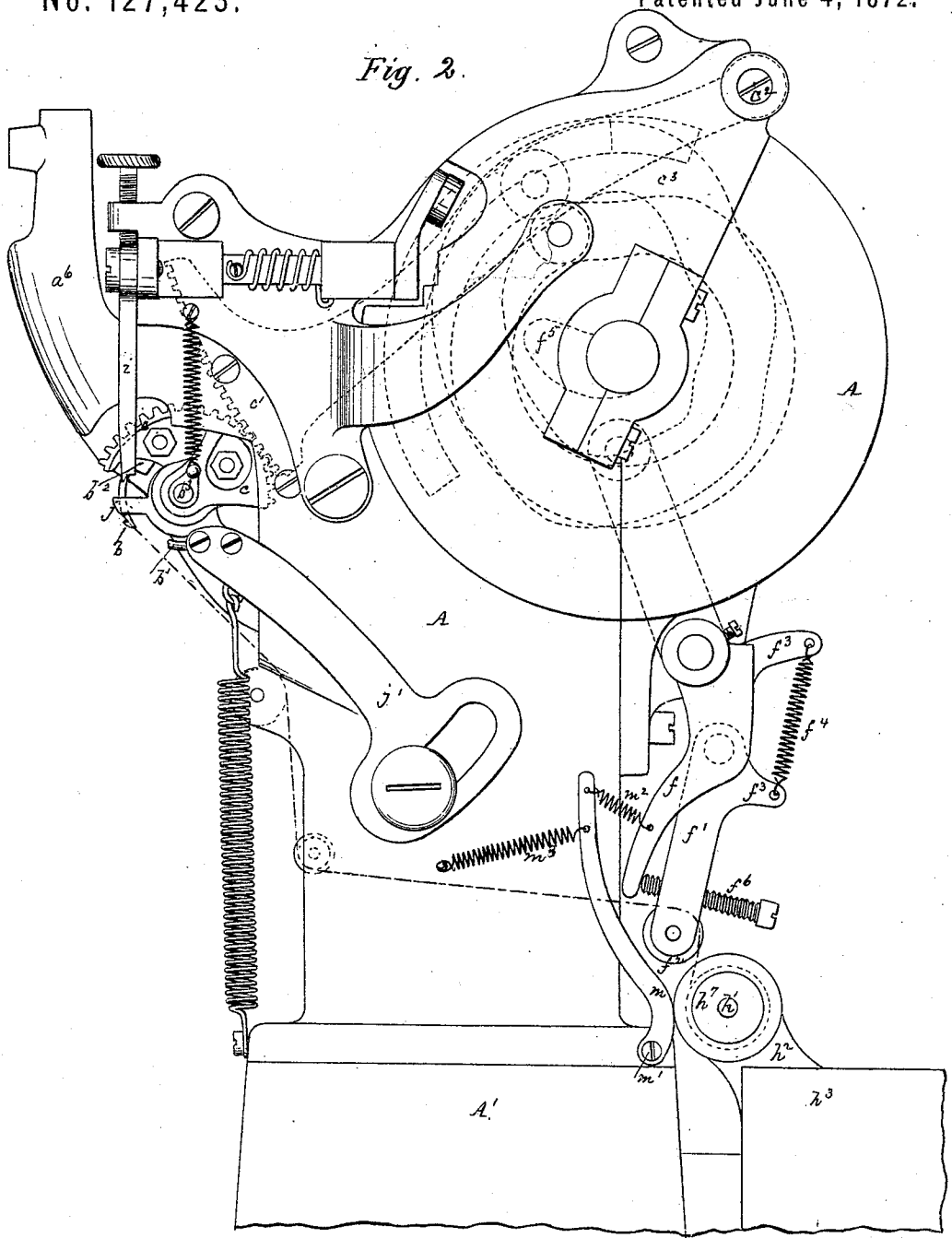

Witnesses

*C. C. Nottingham*  
*Thomas C. Smith*

Inventor

*Daniel Mills*  
by *Stollor*  
*his atty*

DANIEL MILLS.  
Machine for Sewing Boots and Shoes.  
No. 127,423. Patented June 4, 1872.

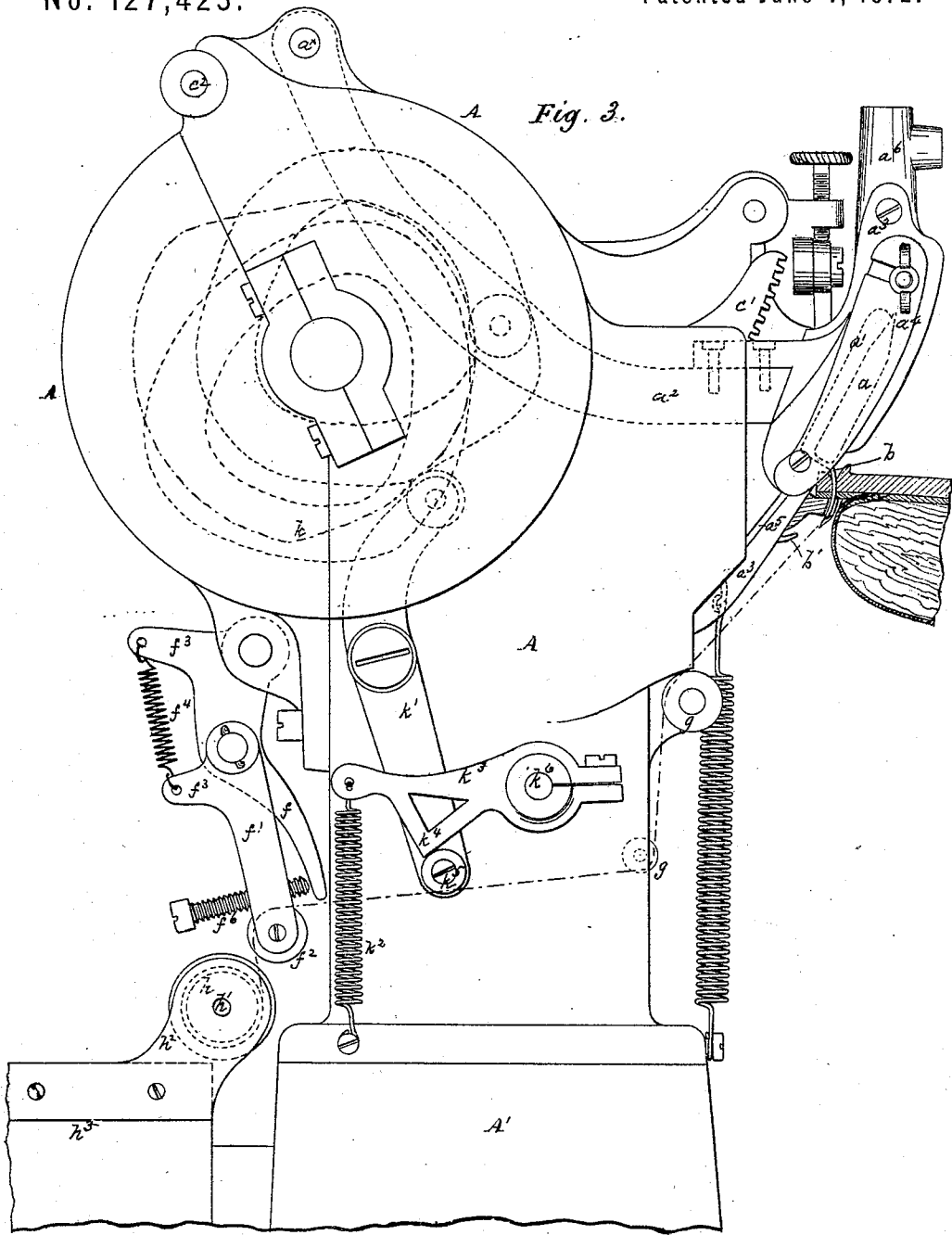

Witnesses  
C. B. Nottingham  
Thomas C. Smith

Inventor  
Daniel Mills  
by A. Pollock  
Attorney

# UNITED STATES PATENT OFFICE.

DANIEL MILLS, OF BROOKLYN, ASSIGNOR TO CHARLES GOODYEAR, JR., OF  
NEW ROCHELLE, NEW YORK.

## IMPROVEMENT IN MACHINES FOR SEWING BOOTS AND SHOES.

Specification forming part of Letters Patent No. 127,423, dated June 4, 1872.

### *To whom it may concern:*

Be it known that I, DANIEL MILLS, of Brooklyn, Kings county, New York, have invented certain new and useful Improvements in Machinery for Sewing Boots and Shoes, of which the following is a specification:

For sewing the welts upon the uppers of boots and shoes, and for sewing the outsoles to the welts, and also for sewing on the soles in what is termed "turned work," by machinery, various arrangements of mechanism have been devised, with a view to the production, in a practicable manner, in the manufacturing sense, of work which shall resemble that of ordinary hand-sewn boots and shoes; and for this object Letters Patent have formerly been obtained by me for machinery in which a single thread is used, the work produced being what is ordinarily called chain or loop stitching; and the series of loops forming the seam or row of stitching is described as being laid by the needle in the channel formed in the sole of the boot or shoe, and afterward covered by the lip raised from the channel, as in ordinary hand-work. By these machines the production of work sewn upon a last and resembling hand-work has been successfully accomplished, and the sewing or stitching so nearly resembles hand-sewing as scarcely to be distinguishable therefrom by experienced operatives. There is, however, one difficulty which is insurmountable in using the aforesaid class of machines, as it arises from the peculiar kind of stitch produced thereby. It is well known to those conversant with the manufacture and use of ordinary sewing-machines that the chain or loop stitch is produced by the interlooping of the successive portions of thread passed through the material by the needle, and, as the loops all lie on one side of the material, there is on that side a thickness of thread corresponding with the number of times the thread is doubled together in forming the loops. This extra thickness in the chain or loop stitch is objectionable, even in working with common sewing-machines, where fine thread is used, and it is obviously much more so where the work necessitates the employment of thick thread with a very short stitch, such as is required in the manufacture of boots and shoes. In the

channel wherein the thread is laid there is only a limited space, and the bulk of the thread is so great that, when the lip of the channel is closed down upon it, a protuberance is formed on both sides of the sole, which is inconvenient and unsightly, and causes considerable difficulty in finishing the shoe; while with thin soles, in some cases, the substance of the leather will not allow the channel to be made deep enough for the loop-stitching. As this difficulty is unavoidable with the loop or chain stitch, it is very desirable that another kind of stitch should be adopted, and I have therefore devised mechanism for sewing on the soles and welts of boots and shoes with two threads, which, being interlocked in forming the seam, produce the work commonly termed the "lock-stitch," in which the threads are carried along equally upon both sides of the material being sewn, so that there is only a single thickness of thread on each side, and there will therefore be no difficulty in properly closing the channel after the sole has been sewn upon the boot or shoe.

In carrying my present invention into practice, I construct the machine with a head for supporting the parts of the mechanism substantially similar to the head described and shown in my former patent hereinbefore referred to, and I use a curved needle and awl and supporting devices of the same general character as those described in the said former patents. I now, however, use, in combination with the needle, a shuttle which carries one of the two threads used in the machine, and I will now proceed to describe, by the aid of the accompanying drawing, the manner in which the needle and shuttle and other parts of the mechanism are combined to accomplish the object of my said invention.

### *Description of the Drawing.*

Figure 1 is a front elevation of my improved machine. Fig. 2 is an elevation of one side, and Fig. 3 an elevation of the other side, of said machine. Fig. 4 shows a detached portion of the machine.

Like letters indicate the same parts throughout the drawing.

The head A of the machine is constructed

of cast-iron or other suitable material, and is supported upon a strong column,  $A'$ , in the usual manner. The shuttle  $a$  is placed in a recess,  $a^1$ , in the end of a vibrating arm,  $a^2$ , and is moved to and fro upon a bed or race,  $a^3$ . The direction of motion of the said shuttle is in the arc of a circle, passing transversely across the line or seam of sewing, and at a right angle, or nearly so, to the plane of the work. The arc of the shuttle's motion is so arranged in relation to the needle  $b$  that, instead of passing through the loops of the thread in a plane parallel with the surface of the work, or in a curve central with the line of the needle's motion, the said shuttle passes upward through the loops obliquely to the surface of the work at each stitch, and the loops, therefore, slip from the shuttle more readily than if the shuttle were carried through the loops in a direction parallel with the surface of the work. The point or nose  $a^4$  of the shuttle is made to project above the surface of the body of the shuttle toward the needle in order that the said point, as the shuttle passes across the race, may reach the needle and take the loop properly therefrom, and the shuttle-race has a narrow groove,  $a^5$ , to receive this projecting nose. The race or bed of the shuttle is a plate, which is secured upon a hollow bracket,  $a^6$ . From the interior of this bracket there is a passage into the interior of the machine head, and the heat from a gas-burner or lamp in the column  $A'$ , which supports the head  $A$ , is conducted into this hollow bracket, and the shuttle-race or bed is thereby heated and the shuttle kept perfectly warm. The thread of the shuttle is aid in and along the channel of the sole throughout the entire length of the stitching, so that the fair side of the stitch is seen. The needle  $b$  and awl  $b^1$  are both secured in the same stock or driver  $c$ , which is provided with teeth and geared in connection with a segment-lever,  $c^1$ , whose fulcrum is a pin,  $c^2$ , secured in the head. The said driver is operated by a cam,  $c^3$ , journaled in suitable bearings in the head. The said needle and awl form portions of a circle, around the center of which they move. The radius of the needle is about one inch. I use a barbed or crochet needle instead of a needle with an eye or hole in it. I thereby make the thread fill the holes properly, as the needle, in rising through the work after each descent, is, with the exception of the hooked or barbed part, withdrawn from the work before the thread is pulled up into the hole, and I am enabled to use a shorter and thinner needle than would otherwise be practicable. Moreover, in the limited space available for my purpose I could not, with any other than a barbed needle, use an awl for perforating the work; but should be compelled to perforate with the point of the needle, it being necessary that the piercing should be done from the welt side of the sole; or, in other words, the piercing instrument should enter into the sole on the side opposite to that on which the shuttle lays its thread. The barb

or hook of the needle is formed on either its outer or its inner periphery, instead of being formed on one side of the needle, so that the shuttle will be sure to enter the loops properly. I use a needle-shield,  $b^2$ , for supporting the needle  $b$ , and which serves also as a barb-coverer for preventing the removal of the thread from the needle-hook before the shuttle has properly entered the loop. This shield has a pivot,  $b^3$ , to receive which the journal of the needle-stock is made tubular, and the said pivot is supported to work freely in the said tubular journal. I employ a take-up mechanism to partly draw up the loops of thread after they have been dropped by the needle at each stitch. This mechanism, for convenience, is arranged at the back of the machine head. The said mechanism comprises a lever,  $f$ , which has jointed to it an arm,  $f^1$ , at whose free end is a roller,  $f^2$ . The said arm and lever are also formed with fingers  $f^3$ , connected together by a spring,  $f^4$ . The thread passes from the tension device hereinafter described to the said roller, and thence over guide-rollers  $g$  to the looper and needle. The take-up lever is actuated by a cam,  $f^5$ , at the proper times to take up or draw back the loop of the thread, and the aforesaid spring  $f^4$ , acting on the jointed arm of the said lever, prevents any slackness of the thread during the action of the looper, which is not here shown, but which is similar in construction and operation to those I have heretofore patented, to throw the thread around the barb of the needle. The said jointed arm is provided with an adjusting-screw,  $f^6$ , by which its position on the lever is changed to regulate the amount of the take-up motion.

To render the take-up more perfectly operative, I combine with it a brake,  $m$ , turning on a pivot,  $m^1$ , and connected with the take-up by a spring,  $m^2$ , so that when the take-up moves back for the purpose of drawing up the loop the brake will at the same time be drawn back and pressed against the tension-spool, hereinafter described, in order to lock said spool; otherwise the thread might be drawn from the spool rather than from the loop, my object being to take up the thread in uniform quantity from the loops. When the take-up is released, the brake may be drawn forward away from the spool by means of a spring,  $m^3$ , as shown in Fig. 2.

The aforesaid tension device is constructed as follows: A small drum or spool,  $h$ , is mounted on a journal,  $h^1$ , which is fixed in a bracket,  $h^2$ , on a trough,  $h^3$ , containing melted wax, the said trough being heated by a gas-burner or lamp. The thread is brought direct from the ball to this trough, and is conducted through suitable guides along the bottom of the same to a stripper, which removes from it the superfluous wax. From this stripper the thread is conducted to the drum, and is coiled twice or three times around the same. A guide-finger,  $h^5$ , is arranged to project down upon the periphery of the drum to insure the delivery of the thread therefrom always in the

same line to the roller of the take-up mechanism. The drum is formed with a flange, which bears against the side of the bracket, and the journal of the drum is provided with a spring,  $h^6$ , which, by an adjusting-nut,  $h^7$ , is caused to press the drum with more or less force against the bracket and so regulate the tension.

A support for the work, consisting of upper and lower jaws, both jaws serving to clamp the work during the formation of the stitches, is not new; nor is the under jaw new as arranged to move concentrically with the needle. But I now modify this device by removing the said upper jaw, the feed-dog  $i$  being so operated and timed that it will both feed the work and perform the functions of the said upper jaw. The feed-dog  $i$  and lower jaw  $j$  are so shaped as to hold the work between them, the lower jaw being a table-like support, while the feed-dog travels in the channel of the sole at or about the place where the needle enters the work, so that the work is fed forward between the stitches by the feed-dog, and slides on the lower jaw or table when the needle has risen out of the work.

The locking and unlocking of the said lower jaw by a positive motion derived from a cam through the feed-dog is not new, and has been before described by me; but I now modify this device by arranging the same to be unlocked by a cam,  $k$ , and lever,  $k^1$ , and locked by a spring,  $k^2$ , when the lever is released from the cam. One end of the spring is connected with an arm,  $k^3$ , which has on it an inclined projection,  $k^4$ . The cam in locking said device forces a roller,  $k^5$ , on this lever over the incline  $k^4$ , and draws it back therefrom to allow the spring  $k^2$  to act. The arm  $k^3$  is fixed on one end of a transverse screw-threaded bolt,  $k^6$ , passing through the head A, and provided on its end, on the opposite side of the machine, (see Fig. 2,) with a head, which rests on that portion of the arm  $j'$  immediately around the slot therein, the said arm  $j'$  being connected with the jaw  $j$ . The movement of the arm  $k^3$  causes the rotation in a corresponding direction of the screw-bolt  $k^6$ , and, according to the direction of this rotary movement, the head of the bolt is screwed up toward or back away from the slotted arm  $j'$ , thus either locking or unlocking the jaw  $j$ .

Having thus fully described my said invention and shown how the same may be conveniently and advantageously carried into effect and practice, I wish it to be understood I am aware that shuttle-machines for sewing boots and shoes have already been used; but in such machines a straight needle is employed, and the work is not placed upon an ordinary last, whereas my present invention is a further development of the system of manufacture set forth in my said former patents, and is therefore confined to machines in which a curved needle is used, and the boot or shoe is sewn upon a last and prepared as for hand-sewing.

Instead of a reciprocating shuttle, as shown, a discoidal shuttle having a rotary movement upon its axis, either continuous in one direction or back and forth, may be used, with a few obvious modifications of the machine, and without departure from the principle of the invention hereinbefore described.

What I claim as my invention, and desire to secure by Letters Patent, is—

1. In such a machine, as specified, for sewing the soles of boots and shoes, a shuttle working transversely across the line or seam of stitching, and obliquely to the surface of the work, when arranged and operating in combination with a barbed needle, and formed with a nose or point projecting beyond or above its own face toward the said needle, as and for the purpose set forth.

2. In a machine, as aforesaid, for sewing the welts and soles of boots and shoes, the barbed curved needle, formed and moving within the small radius described, and operating in combination with the shuttle, which lays its thread in the channel formed in the sole of the boot or shoe, substantially as set forth, for the purpose specified.

3. In a machine in which the barbed needle and the piercing needle move concentrically with each other and operate from opposite sides of the work, in connection with a shuttle and a support for the work, as set forth, I claim the arrangement, substantially as herein described, whereby the shuttle is caused to lay its thread on the side of the work opposite to that on which the piercing instrument enters the same.

4. The curved barbed needle with the barb formed on its outer or inner periphery, in combination with a shuttle moving in a plane parallel with the plane of motion of the needle, as and for the purpose specified.

5. The combination of the curved barbed needle, the needle-shield, and the shuttle, operating together in parallel planes, substantially as and for the purpose set forth.

6. The hollow projecting bracket  $a^6$ , with the flat grooved plate, constructed and arranged as described, to form the race or bed against which the shuttle travels, and having its interior in communication with the interior of the head of the machine, for the purpose of heating the bracket, substantially as set forth.

7. The awl and needle of the said machine, fixed upon the same stock or driver when the said stock is operated by mechanism, constructed substantially as herein described, for the purpose set forth.

8. The needle-shield with its spindle, fitted to turn in the tubular journal of the needle and awl-stock, substantially as set forth, for the purpose specified.

9. In a machine of the peculiar character described for sewing the sole to the welt of a boot or shoe, the feed-dog, (which also serves as a channel-gauge,) carried by a vertically-vibrating lever operated by a cam, and ar-

ranged to operate in combination with a self-adjusting supporting bottom jaw and with the needle, substantially as described, and for the purpose specified.

10. A back gauge or lower jaw, which works concentrically, with the needle formed and arranged to operate in combination with the channel-gauge, substantially as shown and described, so as to compress the work at the point where the needle is about to enter the same, for the purpose specified.

11. The combination, with the supporting lower jaw, of the devices described, whereby at each stitch, just before the needle enters the work, the said jaw is locked by a spring, and is afterward released by a positive motion derived from a cam, substantially as set forth.

12. In combination with the needle, the herein-described take-up mechanism, constructed and operating substantially as set forth, for the purpose specified.

13. The herein-described brake mechanism, combined and operating with the take-up and tension mechanisms, substantially as and for the purposes set forth.

In testimony whereof I have signed my name to this specification before two subscribing witnesses.

DANL. MILLS.

Witnesses:

M. BAILEY,  
A. POLLOK.

3450