

(19) World Intellectual Property  
Organization  
International Bureau



(43) International Publication Date  
1 July 2004 (01.07.2004)

PCT

(10) International Publication Number  
**WO 2004/055590 A2**

- (51) International Patent Classification<sup>7</sup>: **G03B 21/56**
- (21) International Application Number:  
PCT/DK2003/000892
- (22) International Filing Date:  
17 December 2003 (17.12.2003)
- (25) Filing Language: English
- (26) Publication Language: English
- (30) Priority Data:  
PA 2002 01938 18 December 2002 (18.12.2002) DK  
PA 2002 02015 28 December 2002 (28.12.2002) DK  
PA 2003 00328 3 March 2003 (03.03.2003) DK
- (71) Applicant (for all designated States except US): **VIZOO INVEST ApS** [DK/DK]; Gl. Kongevej 7, 5. sal t.v., DK-1610 Copenhagen K (DK).
- (72) Inventors; and
- (75) Inventors/Applicants (for US only): **SIMONSEN, Peter, Allan** [DK/DK]; Jesper Brochmands Gade 15, 2. th., DK-2200 Copenhagen N (DK). **CORELL, Morten** [DK/DK]; Gl. Kongevej 7, 5. sal. t.v., DK-1610 Copenhagen K (DK).
- (74) Agent: **PLOUGMANN & VINGTOFT A/S**; Sundkrogs-gade 9, DK-2100 Copenhagen Ø (DK).
- (81) Designated States (national): AE, AG, AL, AM, AT (utility model), AT, AU, AZ, BA, BB, BG, BR, BW, BY, BZ, CA, CH, CN, CO, CR, CU, CZ (utility model), CZ, DE (utility model), DE, DK (utility model), DK, DM, DZ, EC, EE (utility model), EE, EG, ES, FI (utility model), FI, GB, GD, GE, GH, GM, HR, HU, ID, IL, IN, IS, JP, KE, KG, KP, KR, KZ, LC, LK, LR, LS, LT, LU, LV, MA, MD, MG, MK, MN, MW, MX, MZ, NI, NO, NZ, OM, PG, PH, PL, PT, RO, RU, SC, SD, SE, SG, SK (utility model), SK, SL, SY, TJ, TM, TN, TR, TT, TZ, UA, UG, US, UZ, VC, VN, YU, ZA, ZM, ZW.
- (84) Designated States (regional): ARIPO patent (BW, GH, GM, KE, LS, MW, MZ, SD, SL, SZ, TZ, UG, ZM, ZW), Eurasian patent (AM, AZ, BY, KG, KZ, MD, RU, TJ, TM), European patent (AT, BE, BG, CH, CY, CZ, DE, DK, EE, ES, FI, FR, GB, GR, HU, IE, IT, LU, MC, NL, PT, RO, SE, SI, SK, TR), OAPI patent (BF, BJ, CF, CG, CI, CM, GA, GN, GQ, GW, ML, MR, NE, SN, TD, TG).
- Declaration under Rule 4.17:**  
— as to the applicant's entitlement to claim the priority of the earlier application (Rule 4.17(iii)) for all designations
- Published:**  
— without international search report and to be republished upon receipt of that report
- For two-letter codes and other abbreviations, refer to the "Guidance Notes on Codes and Abbreviations" appearing at the beginning of each regular issue of the PCT Gazette.

(54) Title: A METHOD AND ARRANGEMENT FOR PROJECTING IMAGES

(57) Abstract: Images are projected onto a projection medium comprising a screen (24), which forms an open, light penetrable structure comprising a plurality of light reflecting surface parts. The projection medium may comprise a screen, which is perforated or net-like, such as tulle, or which comprises transparent and opaque or light reflecting-areas. The projection screen may be positioned within a shop or another room having a show window or display window (37) spaced from the screen, and a control device, such as a touch screen (38) for controlling the operation of the projector may be positioned so as to be accessible to a viewer (39) outside the room. Medium comprising a screen (14, 22) forming an open, light penetrable structure being formed by a plurality of adjacent small light penetrable and light reflecting areas, respectively.



WO 2004/055590 A2

**A method and arrangement for projecting images**

The present invention relates to a method for projecting images, preferably moving pictures, onto a projection medium.

5

Conventionally, such images are projected onto a solid, light reflecting screen, and the projected image may be viewed from the same side of the screen as that on which the projector is placed. However, it has also been proposed to use a mist of liquid or solid particles as a projection medium, cf. DE-A- 31 30 638. This kind of projection medium is  
10 difficult to control and is not suited for indoor use.

The present invention provides a new method for projecting images onto a projection medium such that this medium may be made invisible or substantially invisible, whereby a viewer will get the impression that the images, such as moving pictures, projected are  
15 freely suspended or floating in space.

This is obtained by the method according to the invention, wherein the images are projected onto a projection medium comprising a screen forming an open, light penetrable structure being formed by a plurality of adjacent small light penetrable and light reflecting  
20 areas, respectively.

The open structure of the screen may be formed by a plurality of adjacent small light penetrable and light reflecting areas, respectively. Thus, like conventional projection screens the screen according to the invention may be a solid screen made from an opaque  
25 material which has been made transparent in a plurality of small areas so as to form the open structure, or the screen may be made from a transparent material which has been made opaque in selected areas so as to form the open structure. Thus, the desired pattern of opaque areas may be imprinted on the transparent sheet or the material may be made non-transparent in any other suitable manner. As an example, the screen may be formed  
30 by a transparent plastic film, parts of which have been made opaque.

In the presently preferred embodiment, however, the projection medium comprises a screen of a perforated or net-like structure. Such screen has opposite first and second side surfaces, and, preferably, the screen has such a perforated or net-like structure that the  
35 projected images may be watched by a viewer from the second side surface of the screen when these images are projected onto the first side surface of the screen. Alternatively or additionally, the perforated or net-like structure of the screen may be such that the screen becomes substantially invisible to a viewer watching the projected images against a dark background from a position spaced from said first or second side surface of the screen.

It has been found that when the screen has such a net-like or perforated structure the projected images may be watched from any of the opposite sides of the screen, and that the screen may be made substantially invisible to a viewer watching the projected images, 5 which are preferably moving pictures, against a dark background from a position spaced from the screen. Preferably, the transition between the outline of the objects, persons or animals projected and the dark background is blurred or faded.

When the space in which the screen is located and illuminated properly, the projection 10 medium may be made invisible to the viewer and the projected images or moving pictures may in a ghost-like or hologram-like manner look like freely floating in the space or room in which the projection medium is arranged. The images being projected may, for example, be objects, persons and/or other living beings, and the objects or living beings to be highlighted are preferably depicted on a dark or black background (black level 0). 15 Preferably, the transition between the outline of the objects or living beings and the dark background is blurred. Furthermore, residual light from a projector projecting the images should preferably be masked or screened, for example by means of a special lens or by means of a specially shaped light funnel (black wrap) through which the images are projected.

20

The images may be computer generated or projected from a video projector or a computer controlled projector onto one side surface of the projection medium, possibly via one or more mirrors and/or prisms. The projector may then be placed at a convenient location where it is not immediately visible to the viewer or viewers.

25

Opposite sides of the projection medium may be watched at the same time by first and second viewers positioned in front of and spaced from opposite sides, respectively, of the medium. Especially in this case the images projected onto the projection medium or screen may form part of a computer game. In the latter case the viewers may activate control 30 means, such as pedals, steering wheels, joysticks, stepping panels or the like, and thereby interact with the game performance.

The openings or perforations in the net-like or perforated structure of the screen are mutually separated by solid partition parts. These solid parts should preferably have a 35 width, which is only a small fraction of the maximum dimension of the openings or perforations. This means that the total area of the openings or perforations should preferably substantially exceed half the area of the screen and preferably be 2/3 or more. The single opening or perforation should not be too large. Thus, the openings or perforations of the screen should preferably have a maximum dimension in the range of

0.5-2.5 mm, preferably 1-2 mm and more preferred about 1.2-1.5 mm. The screen is preferably white or light and non-glossy.

Each of the openings or perforations may have any shape or outline, and even though  
5 preferred they need not be identical. As examples, the openings or perforations may have a circular or a polygonal, such as a hexagonal, rectangular, square or triangular, shape or outline.

In practice it has been found that tulle, such as bridal veil or bridal tulle, with a net-like  
10 structure defining hexagonal openings is very suitable for use as the screen.

It has been found that a proper veil-like nylon fabric for use as a screen in the method according to the invention is marketed by John Heathcoat & Co. Ltd., Tiverton, Devon, England under the Quality Number A1027 F.

15

In order to make the screen invisible to the viewer the space defined behind said first side of the screen is preferably kept darker than the side of the screen being watched.

Preferably the illumination of the said space is only 10-30 % of the illumination of the side of projection medium facing the viewer.

20

The images are suitably projected on the screen by means of a projector, and the images are preferably projected in a direction defining an acute angle with said first surface of the screen. The projector may then be positioned adjacent to the ceiling, a wall or the floor of a room in which the screen is arranged, whereby the projector may be placed concealed or  
25 invisible to the viewer. Of course the projector may, alternatively, be concealed in other manner, for example covered by a screen.

The projection medium or screen on which the images are projected may be arranged in a horizontal, oblique or a vertical plane. Thus, the screen may, for example, be horizontal  
30 and be arranged above the viewer. In such case moving pictures showing for example airplanes or other flying objects may be projected onto the screen from the upper or lower side thereof. As another example, the screen may be arranged in a room so as to divide the same into first and second chambers defined by said first and second surfaces, respectively, of the screen. A projector may be arranged in the first chamber, which is  
35 preferably kept darker than the second surface of the screen, which may be arranged opposite to and spaced from a show window or a display window of a shop or store. In the latter case the moving pictures being projected may, for example, be a model wearing and changing clothes, which are for sale in the store.

According to another aspect the present invention also provides an image projecting arrangement, comprising means for defining a projection medium comprising a screen forming an open, light penetrable structure, which is formed by a plurality of adjacent small light penetrable and light reflecting areas, respectively, and a projector for projecting  
5 the images onto said medium. This projection medium or screen may be of any of the above mentioned types and structures.

Furthermore, according to a third aspect the present invention provides use of a screen forming an open, light penetrable structure, which comprises a plurality of small light  
10 reflecting, preferably differently orientated surface parts, and a plurality of adjacent small light penetrable areas, respectively, as a projection medium for moving pictures.

Such medium may be defined in any of the manners described above and may, for example, comprise a screen, wherein the open structure has been formed by a plurality of  
15 adjacent small light penetrable and light reflecting areas, respectively. Thus, as examples, the screen may be formed by a transparent film, parts of which have been made opaque, or from a fabric or sheet material having a perforated or net-like structure. Preferably, in the latter case the screen has such a perforated or net-like structure that images projected on one side surface thereof may be watched by a viewer from the opposite side surface of  
20 the screen, and/or that the screen becomes substantially invisible to a viewer watching the projected images against a dark background from a position spaced from the screen.

According to a fourth aspect the present invention provides a projection screen arrangement comprising first and second spaced uprights extending from a floor or ground  
25 surface, said first upright comprising a reel for reeling and unreeling a projection screen thereon, the free end of the screen comprising connecting means for releasably connecting the free end of the screen to the second upright, and biasing means for tightening the screen when extending between the first and second uprights. The uprights may be in the form of sculptural, aesthetic columns, so that they do not unfavourably influence the visual  
30 impression of the room when the screen is not in use. The connection means may be of a very simple type and may, for example, comprise at least one, preferably two, hook member for engaging with the second upright. The screen may be of a conventional type or any of the screen types described above. However, it is preferably made from tulle. In the latter case it may be necessary to reinforce or strengthen the upper and/or lower edge  
35 of the screen by means of a suitable string or line.

The invention will now be further described with reference to the enclosed diagrammatic drawings, wherein

Fig. 1 is a vertical sectional view of a room or shop with an arrangement according to the invention,

Fig. 2 is a perspective side view of the arrangement shown in Fig. 1,

5

Figs. 3 and 4 are vertical sectional views of a shop or a room with further embodiments of the arrangement according to the invention, the projectors being arranged in different positions,

10 Fig. 5 is a projection screen with a reel device mounted at a ceiling,

Fig. 6 is a fragment of the lower part of the screen shown in Fig. 5,

15 Fig. 7 shows vertical sectional views of the lower part of the screen illustrated in Figs. 5 and 6,

Fig. 8 is a front view of a projection screen system mounted on a floor surface,

20 Fig. 9 is a top view of the screen system of Fig. 8 shown in an enlarged scale,

Fig. 10 is a fragmentary view of the upper edge of the projection screen,

25 Fig. 11 a shop or show room with a projection arrangement, which may be operated or activated by a viewer positioned outside the room,

Fig. 12 is front view of a further embodiment of projection screen system as that illustrated in Figs. 8 and 9 in a position of use,

30 Fig. 13 is an exploded view of the system shown in Fig. 12, and

Fig. 14 is the projection screen system illustrated in Figs. 12 and 13 in a storage position.

35 Figs. 1-4 illustrate a room or shop having a pair of opposed side walls 10, a ceiling 11 and a floor 12. An end wall comprises a show window or display window 13. In the embodiments illustrated in Figs. 1-4 a screen 14 extends transversely to the side walls 10 and substantially parallel to and spaced from the window 13, for example with a distance of 4-5 m.

The screen 14 is a net-like or perforated fabric or sheet material, for example bridal veil or tulle. A video projector 15 with a light funnel or light screens 16 (shown in Figs. 1 and 2) projects moving pictures onto the screen 14. In the embodiments shown in Figs. 1, 2 and 4 the projector projects light onto the back side of the screen 14, i.e. the side facing away  
5 from the window 13. The space 17 behind the screen 14 is kept dark, and parts of the room in front of the screen 14 are preferably illuminated by spot lights, not shown.

A person or viewer 18 standing outside the room or shop and looking through the window 13 can then neither see the screen 14 nor the projector 15. However, the viewer will see  
10 the projected moving object or person in the middle of the room like a hologram. As indicated in Fig. 2 a light trap or screen 19 may be arranged at the upper end of the window 13 to suppress or catch reflected or scattered light.

In the embodiment shown in Fig. 4 the projector 15 projects images or moving pictures  
15 onto the backside of the screen via a prism 20, which could be replaced by one or mirrors, if desired. In other respects the arrangements shown in Fig. 4 functions similar to the arrangements illustrated in Figs 1 and 2.

In the arrangement illustrated in Fig. 3 the projector 15 projects images, such as moving  
20 pictures, onto the front side of the screen 14, which means the side opposite to the window 13. The projector 15 is positioned at the upper part of the end wall containing the window 13 so that the projector is invisible to the viewer 18 standing at the outside of the window 13. The images are projected onto the screen 14 via one or more light reflectors or mirrors 21. It has been found that by this arrangement a similar effect may be obtained as  
25 when the images are projected onto the backside of the screen 14 as illustrated in Figs. 1, 2 and 4 and as described above.

Figs. 5-7 illustrate a projection screen 24 and an associated reel device 25, which may be  
30 mounted at a ceiling and from which the screen may be unreeled. The reel device 25 comprises an electric motor 26, which may be operated so as to reel or to unreele the screen 24. The opposite vertical edges of the screen are preferably guided in slits or slots so as to be invisible to the user. As shown in Figs. 6 and 7, a metal strip 27 is preferably connected to the lower edge of the screen so as to ensure that the screen is kept tight and  
35 that the lower edge of the screen 24 is held in contact with a floor surface 28, when the screen is in its unreeled position. Fig. 7 shows alternative positions of the metal strip 27 when contacting the floor surface, and in order to keep the strip 27 in the desired position permanent magnets may be mounted at the floor surface to attract the iron strip 27.

Figs. 8-10 illustrate an alternative projection screen arrangement which is mounted on a floor surface. The arrangement comprises a pair of spaced uprights or columns 29 and 30 extending substantially vertically from the floor surface 28. The upright 29 may function as a reel device 25 containing a reel 31 for reeling a projection screen 24, which may be  
5 unreeled so as to extend between the uprights as shown in Fig. 8. From the reel 31 the screen is passed around a guide roller 32 which to a certain degree is movable parallel to the plane of the extended projection screen 24 and spring biased in a direction so as to tighten the screen. Preferably, the reel 31 is easily exchangeable, so that a fractured or otherwise defect screen may easily be replaced with a new one, and the reel may include a  
10 rewinding device, such as a rewinding spring device of the type conventionally used in roller blinds. Handles 33 with hook-shaped connecting members 34 are mounted on the free end of the screen 24 as shown in Fig. 9. The hook-shaped connecting members 34 may releasably engage with complementary shaped retaining members 35 formed on the upright 30. The screen 24 is preferably made from tulle, and in such case the upper and  
15 lower edges of the screen may be reinforced and kept straight by a string or wire 36 (Fig. 10) attached thereto, preferably by being passed through successive openings of the net-like screen 24.

Fig. 11 illustrates how the image projecting arrangement according to the invention may  
20 be used in a shop or showroom. A projection screen arrangement of the type shown in Figs. 5-7 or in Figs. 8-10 may be mounted in the room such that the screen 24 is spaced from and extends in substantially in the same direction as a window 37 forming part of the walls defining the room. An activation unit, for example in the form of a touch screen 38, is arranged inside and immediately adjacent to the window, so that the touch screen may  
25 be activated by a person 39 standing at the outer side of the window 37. The person or viewer 39 may then select one of a plurality of video shows by touching the window opposite to the corresponding field or section of the touch screen 38. By using the method according to the present invention individuals and or objects may now be presented as if they were moving freely in the room. Thus, as an example one or more models 40 may show a  
30 collection of clothing sold in the shop and selected by the viewer 39 by means of the touch screen 38. The screen 24 may be reeled and hidden within the reel device 25 in daytime when the shop is open, while the arrangement may be active at night after office hours.

The projection screen system or arrangement shown in Figs. 12 - 14 comprises a tubular  
35 upright or column 41, which may have, for example, a polygonal, such as an octagonal, cross-sectional shape, vide Fig. 14. The tubular column 41 is longitudinally divided into stationary and movable column parts 42 and 43, respectively, which may be releasably interconnected in a storage position as shown in Fig. 14. The column 41 contains a reel 44 with a web of a fabric screen 45, such as tulle or bridal veil, wound thereon. The reel 44 is

rotatably mounted in the stationary column part 42, and the free end of the fabric screen is connected to a strip 46 (Fig. 13), which may be connected to the movable column part 43. The stationary column part comprises a base plate or foot plate 47, which is adopted to be fixed to a floor surface so as to hold the stationary column part in an upright or  
5 vertical position, and a top plate or cover plate 48 with a rewinding device 49 for rewinding the fabric screen 45 onto the reel 44 when released.

The movable column part 43 also has a base plate or foot plate 50 integrally connected thereto and adapted to releasably engage with a fastening device (not shown) on the floor  
10 surface, so that the movable column part 43 may be held releasably in an upright or vertical position on the floor surface and transversely spaced from the stationary column part 42 with the screen 45 extending between the column parts as illustrated in Fig. 12.

It should be understood that the arrangement according to the invention could also be  
15 used outdoors at night, and the screen onto which the moving pictures are projected may be arranged horizontally above the heads of viewers, and the projector should then be arranged above or below the screen, as desired. Even though the method and arrangement according to the present invention may be used for any suitable purpose,  
such as for teaching, security and for military purposes, it has been found especially  
20 valuable for advertising or sales promotion purposes.

## CLAIMS

1. A method for projecting images, wherein the images are projected onto a projection medium comprising a screen (14, 22) forming an open, light penetrable structure being  
5 formed by a plurality of adjacent small light penetrable and light reflecting areas, respectively.
2. A method according to claim 1, wherein the screen is formed by a transparent film, parts of which have been made opaque or light reflecting.
- 10 3. A method according to claim 1, wherein the projection medium comprises a screen (14, 24) of a perforated or net-like structure.
4. A method according to claim 3, wherein the projection medium is a screen (14, 24)  
15 having opposite first and second side surfaces and the images being projected onto said first side surface, and wherein the screen has such a perforated or net-like structure that the projected images may be watched by a viewer (18) from the second side surface of the screen.
- 20 5. A method according to claim 3 or 4, wherein the projection medium is a screen (14, 24) having opposite first and second side surfaces and having such a perforated or net-like structure that the screen becomes substantially invisible to a viewer (18) watching the projected images against a more dark background from a position spaced from said first or second side surface of the screen.
- 25 6. A method according to any of the claims 1-5, wherein the images projected onto the projection medium (14, 24, 22) are watched by a viewer (18) from a position spaced from the projection medium.
- 30 7. A method according to any of the claims 1 - 6, wherein the projected images are watched from opposite sides of the projection medium by first and second viewers, respectively, being spaced from the projection medium.
8. A method according to any of the claims 1 - 11, wherein the images are projected onto  
35 the projection medium via one or more mirrors (21) or prisms (20).
9. A method according to any of the claims 1 - 8, wherein the images projected on the projection medium are computer generated.

10. A method according to claim 9, wherein the images projected onto the projection medium form part of a computer game.
11. A method according to claim 10, wherein the viewer or viewers is/are interacting with  
5 the game.
12. A method according to any of the claims 1 - 11, wherein the images are in the form of moving pictures.
- 10 13. A method according to any of the claims 1 - 12, wherein the images being projected comprise objects and/or living beings on a dark background, the outline of the objects or living beings, the transition between the outline and the dark background being blurred.
14. A method according to any of the claims 3 - 13, wherein the openings or perforations  
15 of the screen are mutually separated by partition parts having a width being only a small fraction of the maximum dimension of the openings or perforations.
15. A method according to any of the claims 1 - 14, wherein the light penetrable areas, the openings or perforations of the screen have a maximum dimension in the range of 0.5 -  
20 2.5 mm, preferably 1 - 2 mm and more preferred about 1.2 - 1.5 mm.
16. A method according to any of the claims 1 - 15, wherein the light penetrable areas, the openings or perforations of the screen have a polygonal or circular shape or outline.
- 25 17. A method according to claim 16, wherein the light penetrable areas, the openings or perforations have a hexagonal, rectangular, square, or triangular shape or outline.
18. A method according to any of the claims 3 - 17, wherein the screen is made from tulle.
- 30 19. A method according to any of the claims 1 - 18, wherein the space (17) defined behind the projection medium opposite to each viewer is kept darker than the space in front of the projection medium.
20. A method according to any of the claims 1 - 19, wherein the images are projected in a  
35 direction defining an acute angle with the screen.
21. A method according to any of the claims 1 - 20, wherein the images are projected on the projection medium by means of a projector (15) arranged in a position so as to be non-visible to the viewer or viewers.

22. A method according to any of the claims 1 - 21, wherein the screen (14, 24) is arranged in a room so as to divide the same into first and second chambers, respectively, a projector (15) being arranged in the first chamber (17), which is preferably kept more  
5 dark than the second chamber, which is defined between the screen and a show window or display window (13).
23. An image projecting arrangement, comprising  
means for defining a projection medium comprising a screen (14, 22)  
10 forming an open, light penetrable structure, which is formed by a plurality of adjacent small light penetrable and light reflecting areas, respectively, and  
a projector (15) for projecting the images onto said medium.
24. An arrangement according to claim 23, wherein the screen is formed by a transparent  
15 film, parts of which have been made opaque or light reflecting.
25. An arrangement according to claim 23, wherein the projection medium comprises a screen (14, 24) of a perforated or net-like structure.
- 20 26. An arrangement according to any of the claims 23 - 25, wherein the screen (14, 24) has opposite first and second side surfaces and has such an open structure that the projected images may be watched by a viewer (18) from the second side surface of the screen.
- 25 27. An arrangement according to any of the claims 23 - 26, wherein the screen (14, 24) has opposite first and second side surfaces and has such an open structure that the screen becomes substantially invisible to a viewer (18) watching the projected images against a more dark background from a position spaced from said first or second side surface of the  
30 screen.
28. An arrangement according to any of the claims 23 - 27, wherein the projector is adapted to project images in the form of moving pictures.
29. An arrangement according to any of the claims 23 - 28, wherein the light penetrable  
35 areas, the openings or perforations of the screen are mutually separated by partition parts having a width being only a small fraction of the maximum dimension of the penetrable areas, openings or perforations.

30. An arrangement according to any of the claims 23 - 29, wherein the penetrable areas, the openings or perforations of the screen each has a maximum dimension in the range of 0.5 - 2.5 mm, preferably 1 - 2 mm and more preferred about 1.2 - 1.5 mm.
- 5 31. An arrangement according to any of the claims 23 - 30, wherein the penetrable areas, the openings or perforations have a polygonal and/or circular shape or outline.
32. An arrangement according to claim 31, wherein the openings or perforations have a hexagonal, rectangular, square, and/or triangular shape.
- 10 33. An arrangement according to claim 25, wherein the screen is made from tulle.
34. An arrangement according to any of the claims 23 - 33, wherein the projector (15) is positioned so as to project the images in a direction defining an acute angle with said first  
15 surface of the screen.
35. An arrangement according to any of the claims 23 - 34, wherein the images are projected on the screen by means of a projector (15) arranged in a position so as not to be visible to the viewer (18) or viewers.
- 20 36. An arrangement according to any of the claims 23 - 35, wherein the projection screen (14, 24, 22) is positioned within a shop or another room comprising a transparent wall, such as show window or display window (37) spaced from the screen, the arrangement further comprising a control device (38) for controlling the operation of the projector  
25 positioned so as to be accessible to a viewer (39) outside the room.
37. An arrangement according to claim 36, wherein the control device comprises a touch screen (38) by means of which a viewer may select the images or image program to be projected.
- 30 38. An arrangement according to claim 36 or 37, wherein the control device is arranged at the inner side of the transparent wall and may be activated from the outer side of the transparent wall.
- 35 39. An arrangement according to any of the claims 23 - 38, wherein the projection screen (14, 24) is arranged in a room so as to divide the same into first and second chambers defined by opposite first and second surfaces of the screen, respectively, the projector (15) being arranged in the first chamber (17), which is preferably kept darker than the

second chamber, the second surface of the screen being arranged opposite to and spaced from a show window or display window (37).

40. Use of a screen (14, 24, 22) forming an open, light penetrable structure, which  
5 comprises a plurality of small light reflecting, preferably differently orientated surface parts, and a plurality of adjacent small light penetrable areas, respectively, as a projection medium for moving pictures.
41. Use according to claim 40, wherein the screen is formed by a transparent film, parts of  
10 which have been made opaque or light reflecting.
42. Use according to claim 40 or 41, wherein the screen (14, 24) is formed by a fabric or a sheet material having a perforated or net-like structure.
- 15 43. Use according to any of the claims 40 - 42, wherein the screen has such an open structure that images projected on one side surface thereof may be watched by a viewer (18) from the opposite side surface of the screen (14, 24).
44. Use according to any of the claims 40 - 43, wherein the screen (14, 24) has such a  
20 perforated or net-like structure that the screen becomes substantially invisible to a viewer (18) watching images projected thereon against a dark background from a position spaced from the screen.
45. Use according to any of the claims 40 - 44, wherein the light penetrable areas, the  
25 openings or perforations of the screen (14, 24) are mutually separated by partition parts having a width being only a small fraction of the maximum dimension of each penetrable part, opening or perforation.
46. Use according to any of the claims 40 - 45, wherein the light penetrable areas, the  
30 openings or perforations of the screen (14, 24) have a maximum dimension in the range of 0.5 - 2.5 mm, preferably 1 - 2 mm and more preferred about 1.2 - 1.5 mm.
47. Use according to any of the claims 40 - 46, wherein the light penetrable areas, the openings or perforations have a polygonal or circular shape or outline.  
35
48. Use according to claim 47, wherein the openings or perforations have a hexagonal, rectangular, square, or triangular shape.
49. Use according to any of the claims 40 - 48, wherein the screen is made from tulle.

50. A projection screen arrangement comprising first and second spaced uprights (29, 30) extending from a floor or ground surface (28), said first upright (29) comprising a reel (31) for reeling and unreeling a projection screen (24) thereon, the free end of the screen
- 5 comprising connecting means (34) for releasably connecting the free end of the screen to the second upright (30), and biasing means (32) for tightening the screen when extending between the first and second uprights.
51. A projection screen arrangement according to claim 50, wherein the connection means
- 10 comprise at least one hook member (34) for engaging with the second upright (30).
52. A projection screen arrangement according to claim 50 or 51, wherein the screen is made from tulle.
- 15 53. A projection screen arrangement according to any of the claims 50-52, wherein the upper and lower edges of the screen are reinforced by strings or lines (36).

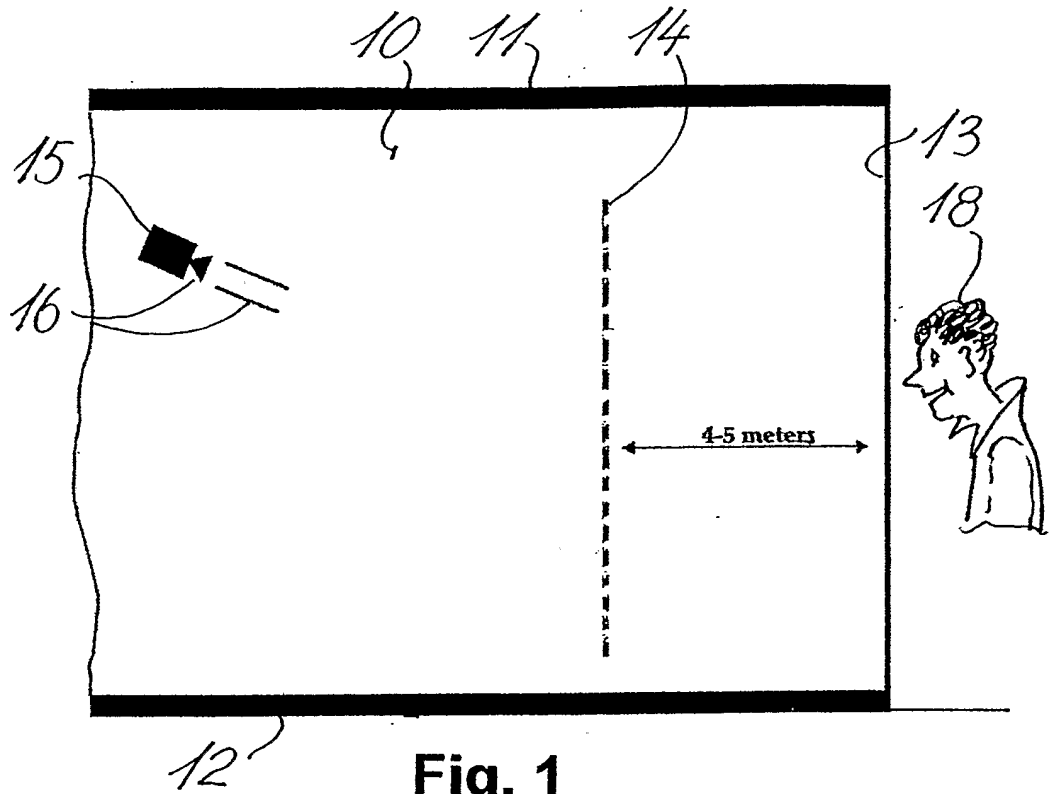

**Fig. 1**

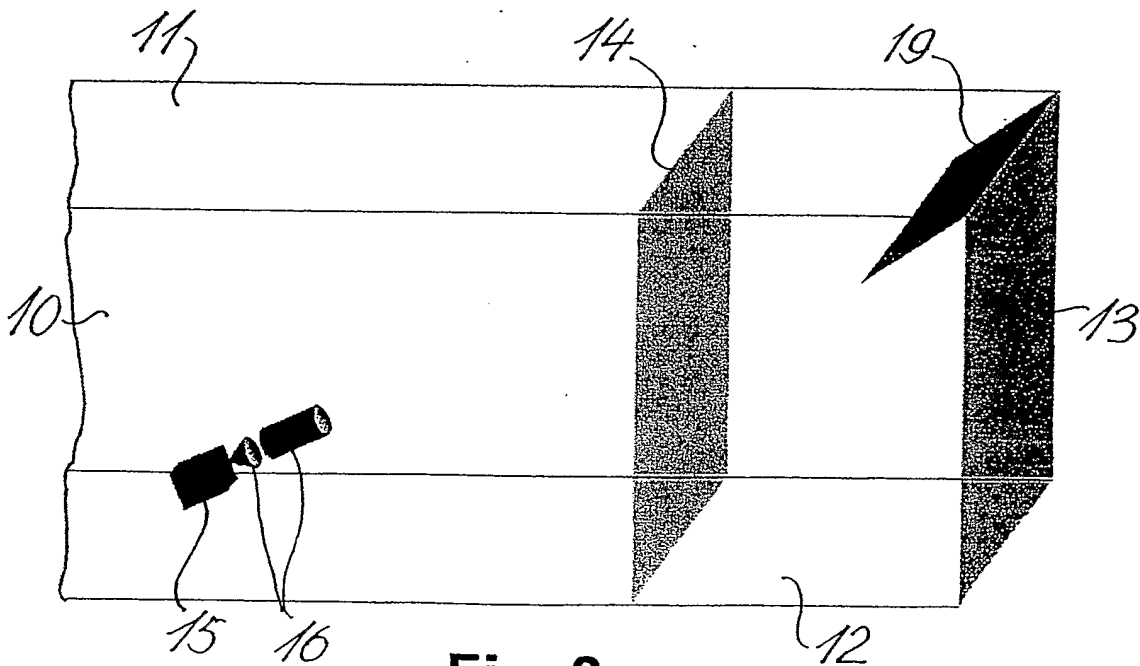

**Fig. 2**

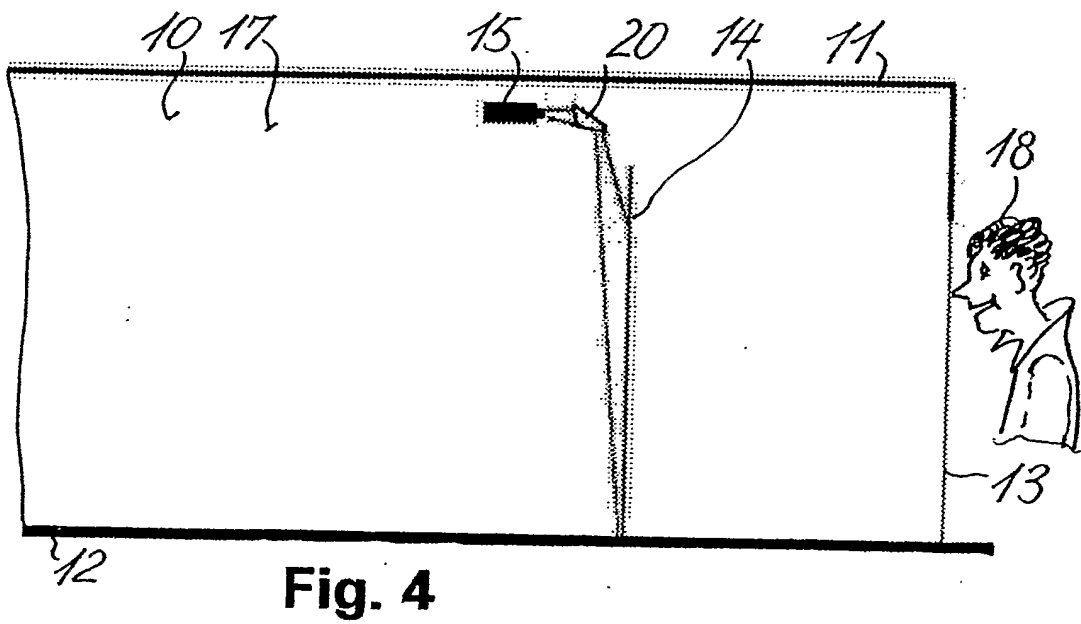
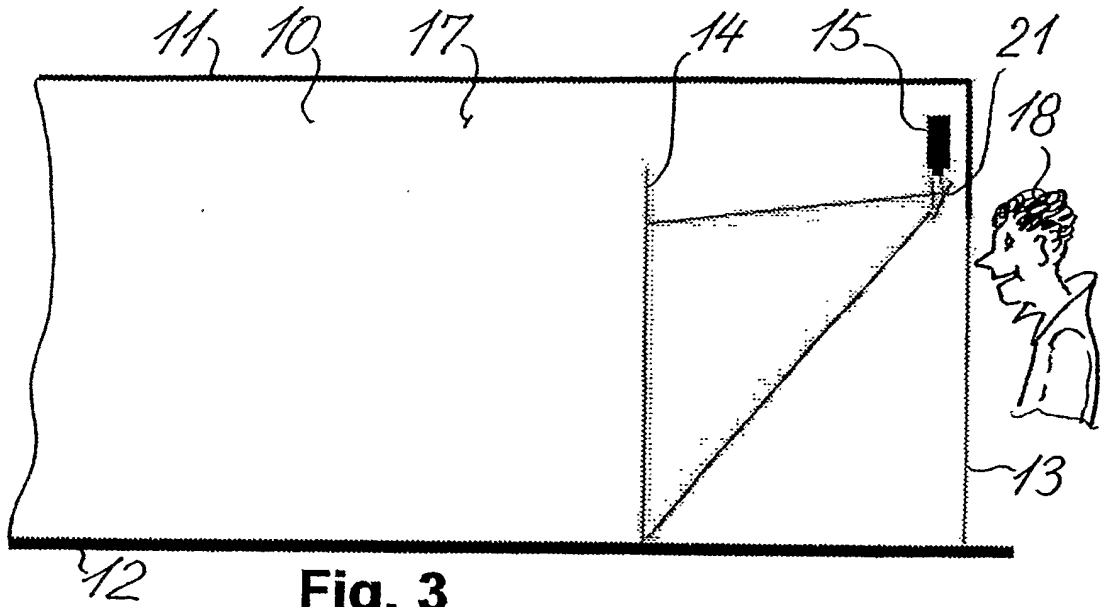

3/6

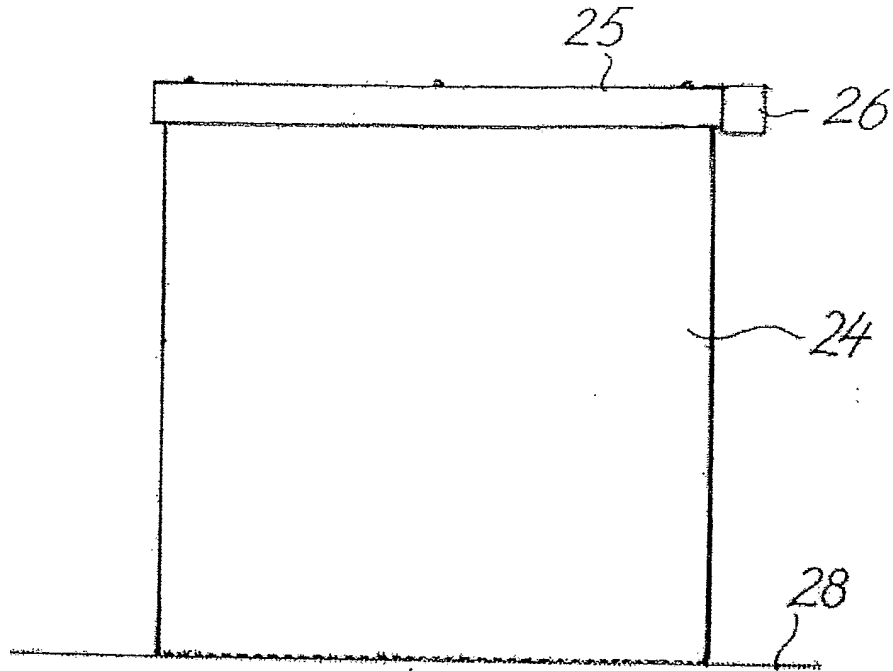

**Fig. 5**

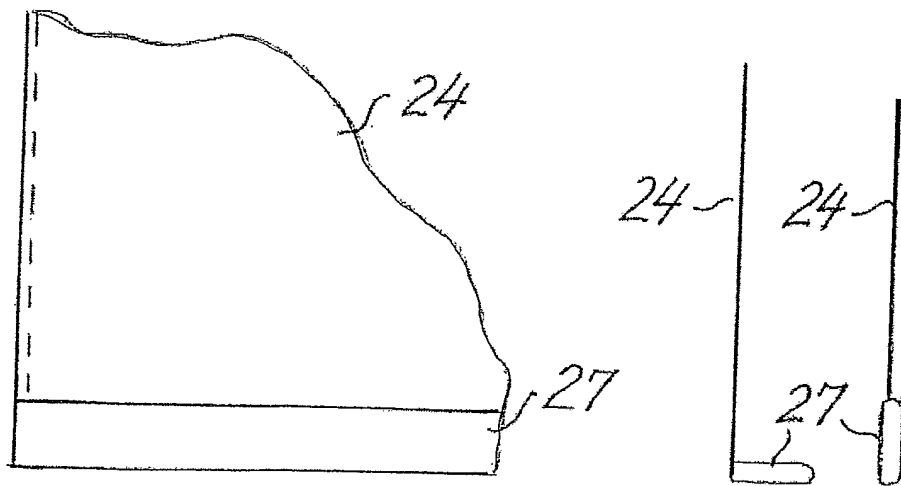

**Fig. 6**

**Fig. 7**

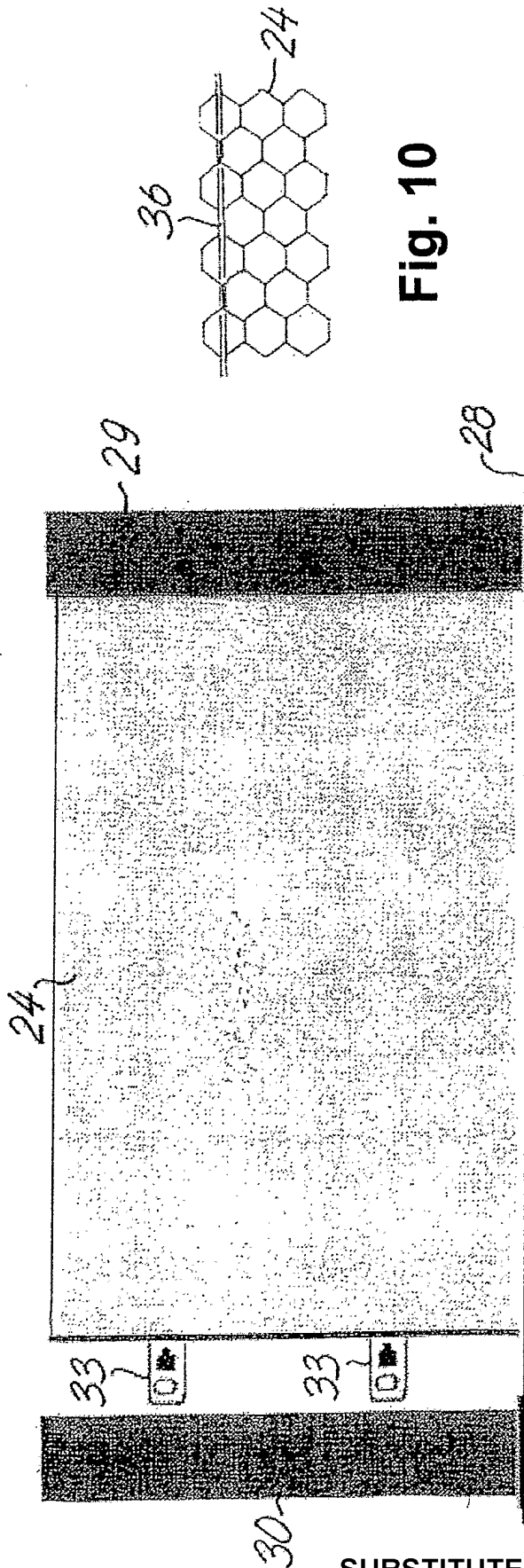

Fig. 10

Fig. 8

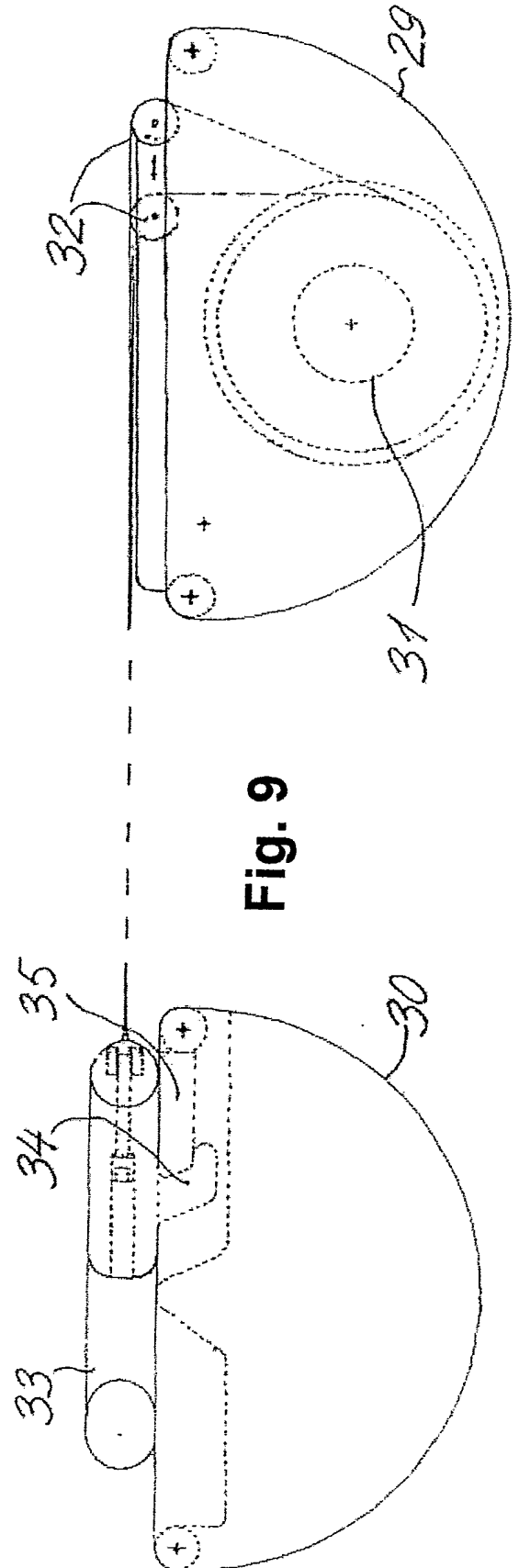
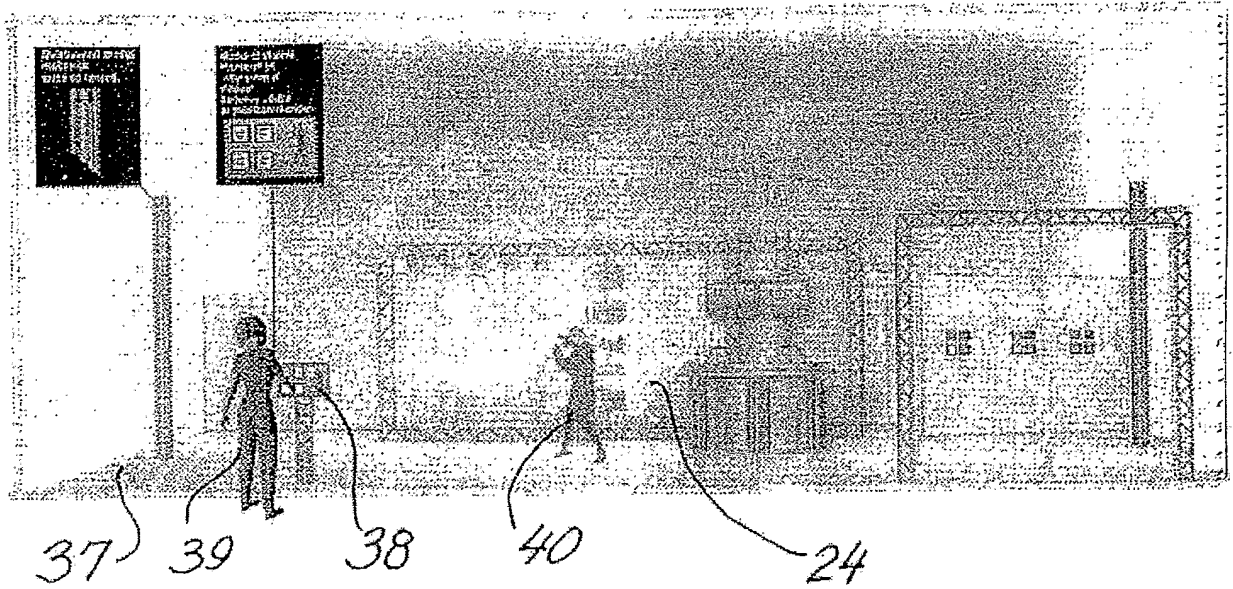
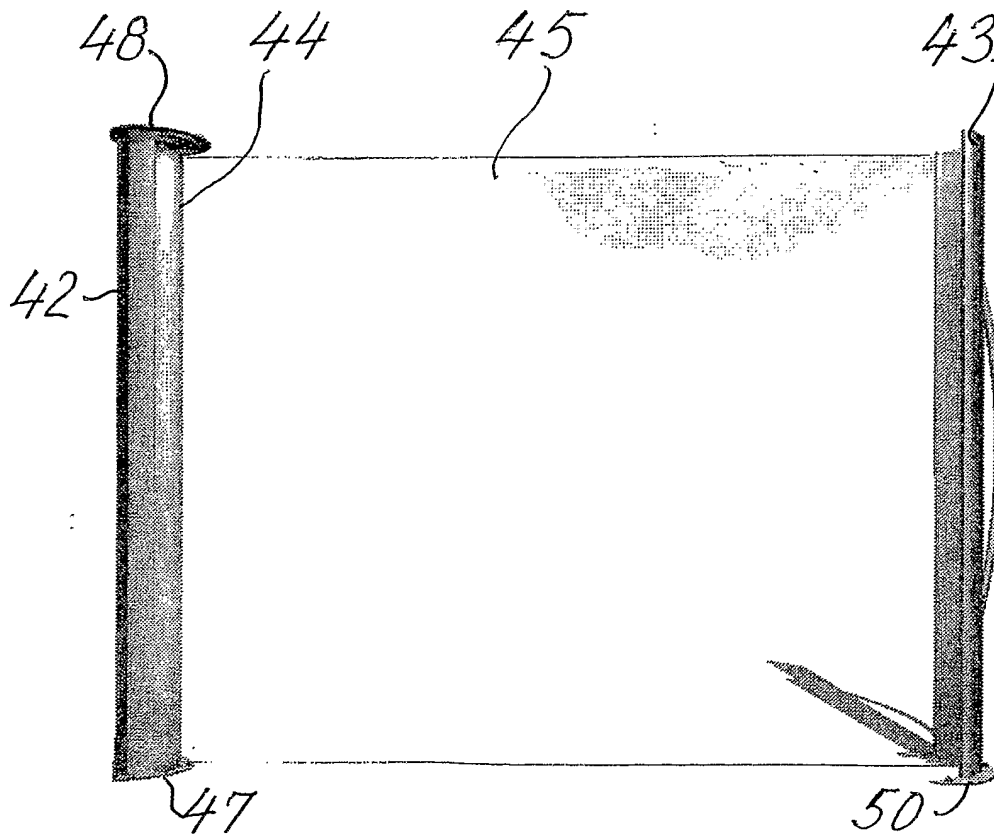

Fig. 9



**Fig. 11**



**Fig. 12**

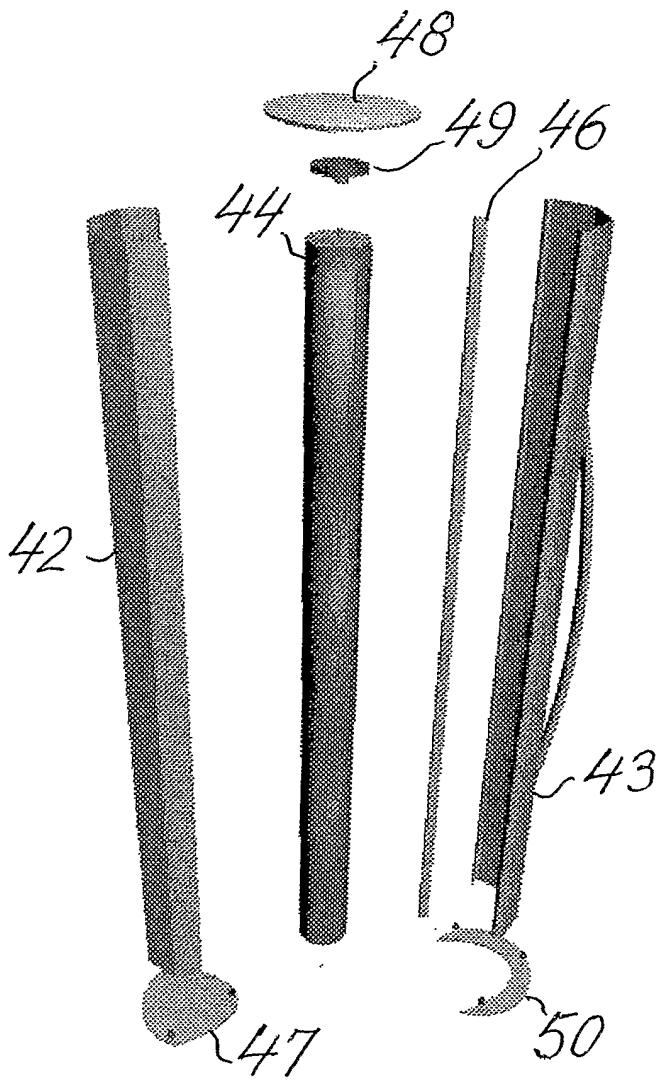

**Fig. 13**

**Fig. 14**

