

(No Model.)

2 Sheets—Sheet 1.

G. R. WILLIAMS.
BUTTON MACHINE.

No. 295,705.

Patented Mar. 25, 1884.

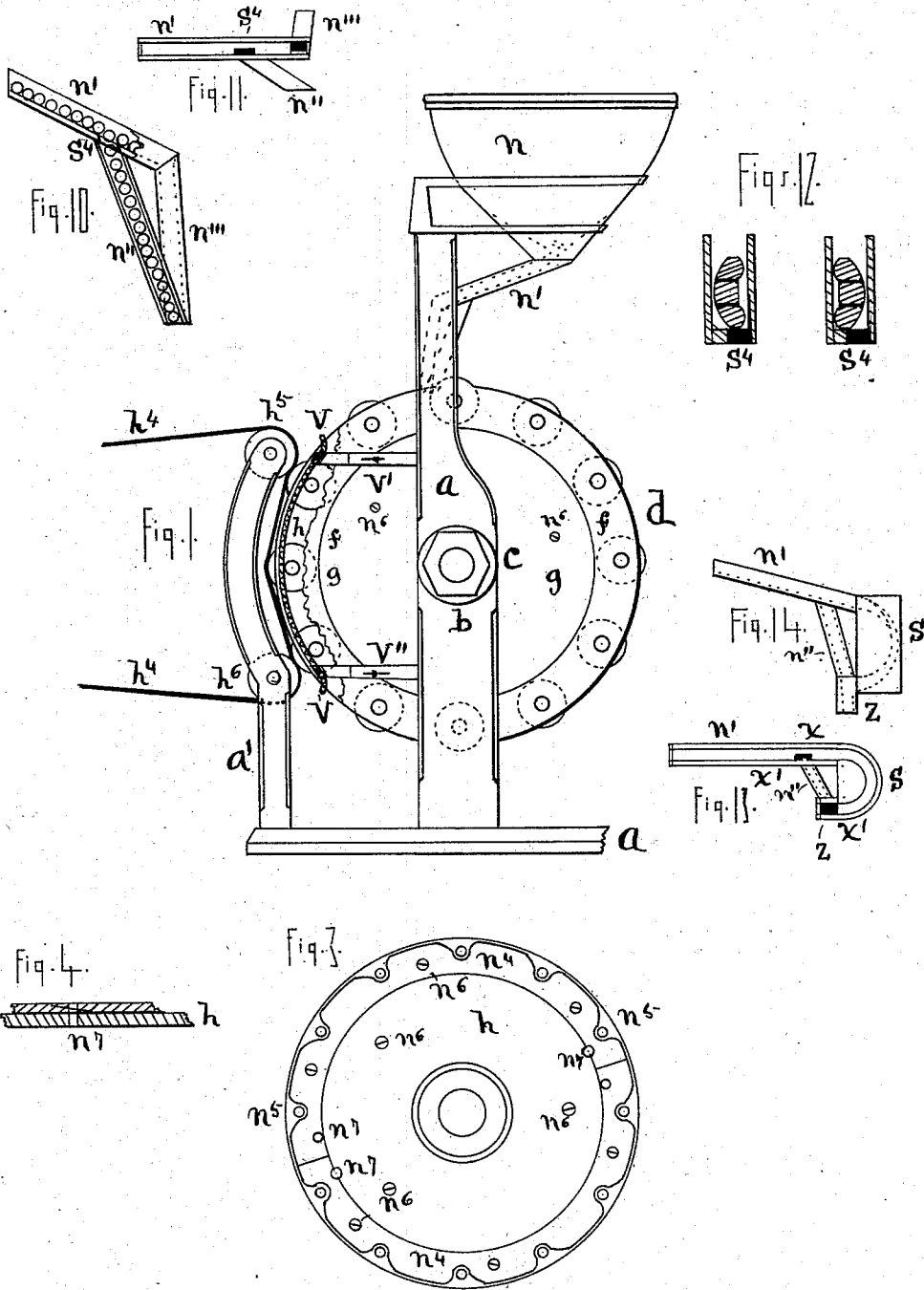

Witnesses.
S. J. Parker.
F. J. Parker.

INVENTOR.
Geo. R. Williams.

(No Model.)

2 Sheets—Sheet 2.

G. R. WILLIAMS. -BUTTON MACHINE.

No. 295,705.

Patented Mar. 25, 1884.

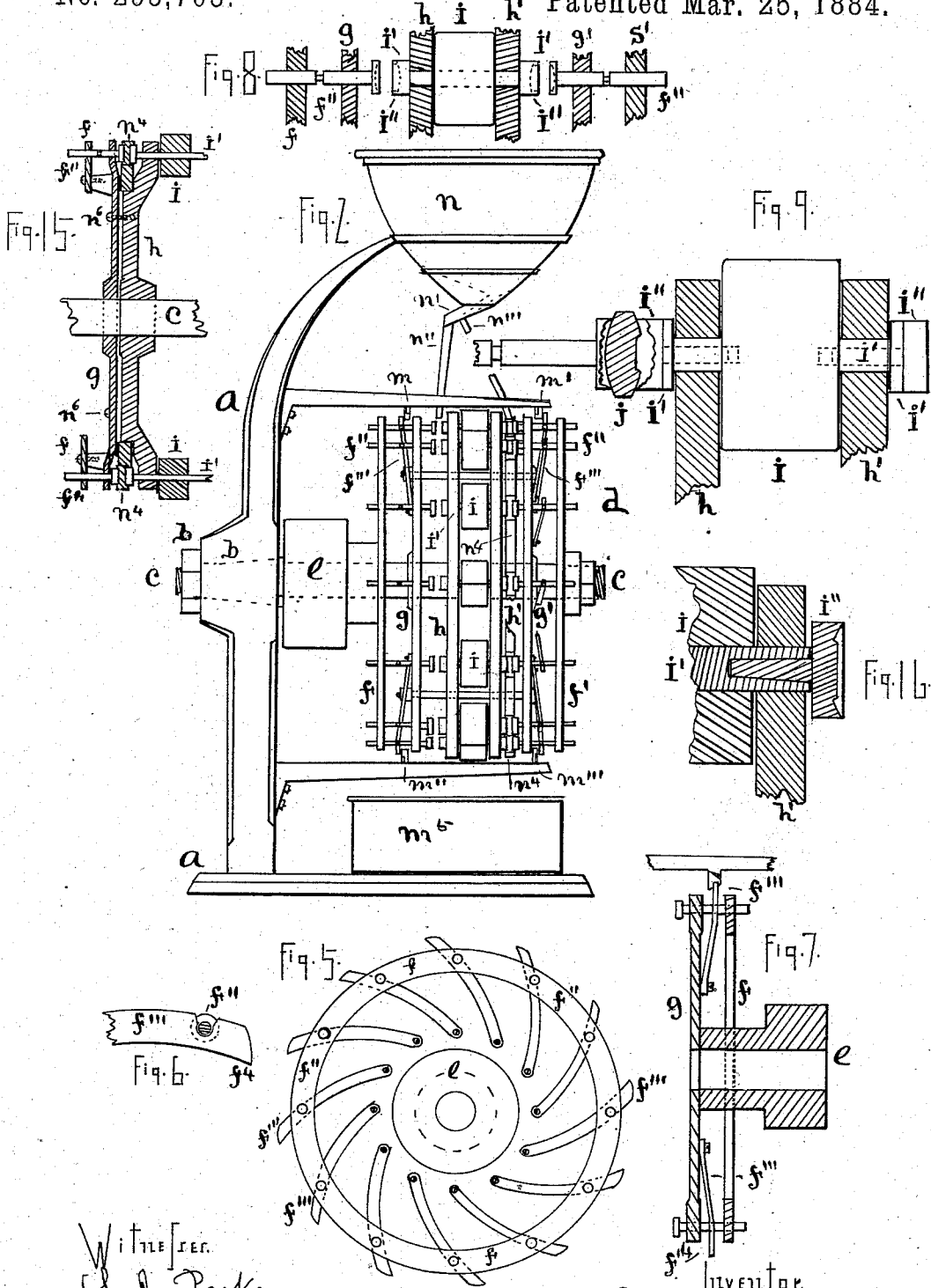

WITNESSES:
A. J. Parker,
F. J. Parker.

INVENTOR:
Geo. R. Williams,

UNITED STATES PATENT OFFICE.

GEORGE R. WILLIAMS, OF ITHACA, NEW YORK.

BUTTON-MACHINE.

SPECIFICATION forming part of Letters Patent No. 295,705, dated March 25, 1884.

Application filed August 23, 1883. (No model.)

To all whom it may concern:

Be it known that I, GEORGE R. WILLIAMS, a citizen of the United States, residing at Ithaca, Tompkins county, New York, have invented an Improved Machine for Smoothing the Edges of Buttons, of which the following is a specification, reference being had to the accompanying drawings.

My invention relates to a machine with the following parts: first, a lathe-wheel containing a series of mandrels or lathes, each of the ends of which is utilized for polishing buttons; second, the belt, which gives rapid motion to these lathes during a certain part of its rotation; third, a series of sliding and revolving spindles, which act as clamps or button-holders, and are actuated by springs and cams while the lathe-wheel revolves; fourth, a hopper whence the buttons are fed to the lathe-chucks; fifth, a feed-spout that automatically separates the buttons as they come from the hopper; sixth, a guide-plate (or series of plates) that assists the entrance of the buttons into the chucks; seventh, a file or tool that polishes the edges of the buttons. These parts, as well as others associated with them, will be apparent as I describe my invention.

Figure 1 is an end view or elevation of my machine, showing especially the smoothing-file or polishing-tool in the space between the lathe or mandrel-supporting plate and the spindle-supporting disk, and the belt which rotates the button-lathes. Fig. 2 is a side view especially designed to show the plates and disks which compose the lathe-wheel. Fig. 3 is a view of the outer surface of one of the guide or centering plates attached to it. Fig. 4 is an enlarged sectional edge view of the joining of the ends of the parts of the guide-plates to each other. Fig. 5 is a view of one of the spindle or button clamping disks, with its rim attached to it, and of the springs which operate the spindles. These spindles clamp or hold the backs of the buttons while they are in the lathes. Fig. 7 is a sectional view of one of the disks and of its rim, and the positions of two of the spindles and of their springs and of the top cam that opens the clamping-spindles to receive the buttons are also shown. Fig. 8 is an enlarged sectional view of any one of the lathes of the lathe-wheel and of its two spindle-clamps

in their disks and rims. Fig. 9 is one of the lathes further enlarged, with a spindle-clamp on the left hand holding a button in a lathe-chuck. Fig. 10 is a button-feed spout with two delivery-spouts therefrom, one leading to the spindle-clamps of one side of the lathe-wheel and the other to the other side of the lathe-wheel. Fig. 11 shows the same feed-tube from above and its two delivery-spouts diverging to each side of the lathe-wheel. Fig. 12 are two sectional views of the openings of Fig. 11, and exhibits the buttons, one about to fall into one of the dark spaces of Fig. 11 or the delivery-spouts and the other rolling by on a ledge of the base of the spout. Fig. 13 is a modification of the feed-spout, showing the first or left-hand delivery-spout opening precisely as in Figs. 11 and 12; but there is a descending curved delivery-spout in place of the right-hand spout of the just-named figures, causing a half-revolution or turning about of the buttons as they roll down it. They then enter the same delivery-spout alike. Fig. 14 shows the curved delivery-spout by side elevation. Fig. 15 is a section of a plate, guide-plate, and disk, with set-screws that fasten the whole together. Fig. 16 shows the chuck of the lathes enlarged.

In the figures, *a a* is the frame of the machine, and *b* is a knob or enlargement of the frame, through which the arbor *c* passes, and by which it is held, on which is the revolving lathe wheel *d*. The lathe-wheel is rotated by a band from any convenient source of power on the pulley *e*, Fig. 2. This lathe-wheel has in its outer circumference, equally distant apart, lathes. (Shown in the figures to be twelve in number.) These lathes are simply a pulley, *i*, on a mandrel, *i'*, with apertures in each end of the mandrels, in which are placed removable wooden chucks *i''*, that are fitted to the size of the button *j*, Fig. 9, whose edges are to be smoothed, and are changed with each size of buttons made. This use of two chucks—one at each end of each mandrel—duplicates the lathes, or allows each end of each lathe to be utilized. The lathe-wheel is composed of plates, disks, and rims, arranged parallel to each other and at right angles to the arbor *c*, on which they turn. Two of them—the central ones—are the plates *h h'*, Fig. 2, which

are plain and simple, having the arbor-aperture in them at their centers and the lathe-mandrel apertures near their outer edges, and these two plates are fast to each other and revolve together. They form a revolving frame or wheel, carrying the mandrels or lathes and other mechanisms, as hereinafter described, held firmly in one structure. On each side of these plates, further outward from the medium plane of the wheel, on each side of the just-named plates, are the disks $g g'$, which are also plain in their structure, with central apertures for the arbor c —one the fellow of the plate h and the other the fellow of the plate h' —and attached to the disks are two partial disks or rims, $f f'$. (Seen in section in Fig. 7.) These rims are circular pieces or flat rings of metal the size of the disks $g g'$, extending toward the arbor c only a short distance, and fast to the disks, and revolve with them. These disks and rims sustain the spindles or button-clamps f'' , and hence they have apertures that hold the spindles, adjusted similarly to the lathe-mandrels, except that the spindles have an endwise motion as well as rotation, revolving with the lathe-mandrels whenever buttons are in the lathe-chucks, and are kept in contact with the lathe-chucks by the springs f''' —one to each spindle—and acting on the spindle by a groove cut in the spindles, as shown in Fig. 6, thus making a series of spindles and springs equal in number to and adjusted to fit or be opposite each its lathe-mandrel. The buttons enter each its chuck as the lathe-wheel is revolving, and these spindles or button-clamps (see Fig. 9) revolve with the buttons, and the lathe of which it is a fellow, by the revolution of the lathe being communicated through the button. The springs f''' are preferably flat, as seen in Fig. 5, but may be other shaped and arranged differently. Cams $m m'$ are at the top of the wheel, and at the bottom are similar cams, $m'' m'''$, which open these spindle-clamps. These cams act, for convenience, on the projecting ends of the springs, and thus on the spindles; but other points of action may be selected, as on flanges or projections on the spindles themselves. The cams at the bottom open the spaces between the lathe-chucks and spindles, and buttons, with their edges finished, drop out of the chucks as they successively arrive at these cams. When the cams at the top open the spindles, buttons drop into recesses or pockets in the guide-plate n^4 , hereinafter to be described, and then are presented to the chucks as they successively arrive at the top. Next, on one side of the wheel is placed the means of revolving the lathes, as seen in Fig. 1, and it consists of the standard a' —a part of the frame of the machine which has the pulleys $h^5 h^6$, over which runs the belt h^4 from any convenient source of power. The pulleys hold the belt, so that one after the other, by the revolution of the lathe-wheel, the lathe-pulleys come in contact with the belt, and are revolved, as it is shown they can be, for a cer-

tain space, (that or about that shown,) the lathes being rapidly revolved, and with them the buttons clamped by the spindles in the chucks in each end of each lathe-mandrel, this rapid revolution having been the object of the parts of the machine so far described. Next it will be noticed that in Fig. 1 a polishing-file, v , is shown in its place between the disk g and the plate h , portions of the rim f and disk g having been cut away to show it; and which file is held by the arms $v' v''$ in such a position that the edges of the buttons are smoothed. The curve of this tool fits the curve of the lathe-wheel, and in width is suited to the space between the plate h and disk g . This file, as already intimated, is adjustable by set-screws in the arms, but may be held by springs the better to fit any want of proper centering in the lathe-chucks. On each side of the lathe-wheel is a file or tool, for the tool may be a steel file, a piece of polishing-stone, emery-stick, or other article. Next, the method of feeding the buttons to the lathe-wheel: This consists of a hopper for holding a supply of buttons, in the bottom of which is an opening, through which the buttons slide or are fed to the inclined spout or conductor n' . The position of the hopper is of but little consequence, but is shown directly over the lathe-wheel. The delivery-spouts $n'' n'''$ receive the buttons by devices to be described, and they are of the inclination and length necessary to reach the U-shaped cavities in the edge of the guide-plate n^4 . The buttons slide unarranged into the tube n' , and its channel is only wide enough for one button to roll edge-wise in it, but long enough to receive many buttons; hence the buttons are in a series in this channel, as shown in Fig. 10, and some will be with their faces one way and some with their faces the other way. Next, buttons, as they roll down the channel n' , have an edge nearer one side of the button-channel than to the other side of the tube or channel, and hence, if the bottom of the tube n' is cut away, making an opening or aperture in it nearer one side of the channel than the other, as is shown in Figs. 11 and 12, some of the buttons that roll down the channel will have their edges to enter the aperture s^4 , and some cannot enter this aperture, and thus all buttons, no matter how faced in the channel, will either drop through that aperture and go into the delivery-spout n'' or will roll on their edges by it on the ledge or uncut-away part of the bottom of the tube n' , and, passing the delivery spout n'' , will fall into the other spout, n''' . Thus the buttons will be automatically separated and go to the right or to the left hand duplication of the lathe-wheel, the delivery-spouts connecting the just-named apertures with the lathe-wheel spaces being made to diverge to each side of the lathe-wheel, as seen in Fig. 11 and elsewhere. Next, when the buttons are thus guided to the lower ends of the spouts $n'' n'''$, the guide-plate

n^4 , Fig. 3, which is fast between the plates h and g , Fig. 16, receives the edges of the buttons on its outer or convex surface, which surface has the excavations or cavities n^5 in it. The buttons then will roll or drop into these cavities n^5 , when the cam m at the top of the lathe-wheel moves the spring f''' , and thus moves the clamp-spindles away from the mandrels of the lathes. The button, now having entered the mandrel-chuck by the rotation of the lathe-wheel, passes this cam, and the spring, released, acts and holds the spindle to the button and the chuck, thus clamping the button, as has been shown in Fig. 9, until the cam m'' opens the spindle and drops it into the receptacle m^5 , the smoothing file or tool v , band h^4 , and other parts acting as has been stated as the button passes the smoothing-space. The other duplication of the lathe-wheel acts in like manner, and so goes on the action of these parts as they reach both the top, the side, and the bottom of the lathe-wheel positions. The guide-plate n^4 is made of two parts, joined by a lap (shown in Fig. 4 in section) and set-pins n^7 . By this lap-junction the two parts of it are easily put in and taken out, since a guide-plate must be made fit each size in diameter of buttons manufactured. Fig. 15 shows the manner of securing these two halves in the wheel, which is that the set-screws n^6 , which hold the disk g to the plate h , Figs. 1 and 3, are loosened and the disk and plate separated a little, when the halves of the guide-plate easily go in, when these screws are tightened and the guide-plate is clamped between the plate and disk, as shown in Fig. 15. Another device is seen in Figs. 13 and 14. It is a variation of the feed and delivery spouts described, but more difficult to comprehend. It consists of the tube n' , with a cut-away aperture, s^4 , as has been described, and which takes all the buttons faced one way; but the buttons faced the other way enter a curved descending-tube, s , and are by it turned half-way about as they in single file descend this curved channel of the delivery-spout. In Fig. 13 the buttons are either faced toward x or toward x' . It is clear that, if there were no descent in the channel in the curve at the right hand of Fig. 13, the buttons rolled from x' to x'' would be changed half about. The descent in a curved channel makes no difference with that fact; hence those buttons faced toward x' fall into the cavity s^4 , and those that face toward x go on by the ledge left in the bottom of the spout n' , and enter the curved descending delivery-spout, which switches or faces them half about by its curve as they run down it, and when the buttons get to the base of this spout they are faced the same way as those that went through the aperture s^4 . This permits two kinds of buttons to be worked by a machine at the same time by duplicating the hopper, downward-inclined spout n' , the delivery-tube n^4 , and channel s .

Fig. 14 shows in elevation the same parts as Fig. 13. It has, however, an annex or common lower end delivery-spout, z , into which all the buttons come, and which is deflected to deliver them to either side of the lathe-wheel, as may be selected. Dotted lines indicate the channels. One-half of the lathe-wheel in Fig. 2 has some of the springs and some other parts omitted, that the plates, disks and rims, lathes, and spindles be not obscured; but in Fig. 15 they are more fully shown. The wooden chucks of the lathes are, perhaps, better seen in Fig. 16, where the parts already described of pulley, mandrel, sustaining-plates are shown, with the wooden chuck i'' in the mandrel. The rest of the machine I have made is apparent to those familiar with the art to which it appertains.

What I claim as my invention is—

1. In a machine for smoothing the edges of buttons, the receptacle which holds a supply of buttons, in combination with tubes or channels, substantially as shown, which automatically separate and convey the buttons to their appropriate places in the machine.

2. An inclined channel down which the buttons roll singly in a series, provided with apertures in the base of it—one nearer one side than the other—whereby the buttons faced one way fall into the one aperture, and the buttons faced the other way pass on by the bridge left in the channel-base for their edges to roll on and fall into the other aperture.

3. A curved delivery-channel connected with one or the other aperture in the main channel through which buttons descend singly in a series, whereby buttons wrongly faced in the main channel are reversed.

4. In a button-smoothing machine, the guide-plate held in suitable relation to the lathe-holding disk or disks, and provided with U-shaped recesses or pockets, in combination with the lathes, lathe-chucks, and the clamping-spindles.

5. A lathe-wheel with a series of lathes near its circumference, in combination with a stationary concave tool held in proximity to and adjustable to the buttons in the lathe-chucks, whereby as the wheel revolves the edges of the buttons are rotated in contact with the tool.

6. The combination of a revolving button-finishing wheel having lathes and clamping-spindles with cams which open by means of projections on the spindles or their springs, a space between the spindles and lathes to receive the buttons before the finishing-tool is reached, and which also open said spindles from the lathes to discharge the buttons after the finishing-tool is passed.

7. The combination of the main or feeding channel having separating-exits in its base with the conveying-spouts which connect said main with the chucks of the lathes.

8. The spindle supporting rims $f f'$, in combination with the spindle-supporting disks g

g' , whereby a frame with rotation on the axle c is made.

9. The lathe-plates $h h'$, constituting the lathe-frame, in combination with the lathes, 5 said plates or disks being on an axle, c , and rotating thereon.

10. The band h^t , provided with pulleys in a supporting standard or part, in combination

with the button-lathes, which band rotates the lathes while the buttons are passing the finishing-tool.

GEO. R. WILLIAMS.

Witnesses:

O. L. WILLIAMS,
S. J. PARKER.