



(51) International Patent Classification:

H01F 38/14 (2006.01) H02J 50/00 (2016.01)
H02J 7/02 (2016.01) H02J 50/10 (2016.01)

(21) International Application Number:

PCT/US2016/024483

(22) International Filing Date:

28 March 2016 (28.03.2016)

(25) Filing Language:

English

(26) Publication Language:

English

(30) Priority Data:

62/139,785 29 March 2015 (29.03.2015) US

(72) Inventor; and

(71) Applicant : MANIKTALA, Sanjaya [US/US]; 4405 Peralta Blvd., Fremont, CA 94536 (US).

(74) Agent: SCHEPLER, Wendi, R.; White & Case LLP, Patent Department, 1155 Avenue of the Americas, New York, NY 10036-2787 (US).

(81) Designated States (unless otherwise indicated, for every kind of national protection available): AE, AG, AL, AM,

AO, AT, AU, AZ, BA, BB, BG, BH, BN, BR, BW, BY, BZ, CA, CH, CL, CN, CO, CR, CU, CZ, DE, DK, DM, DO, DZ, EC, EE, EG, ES, FI, GB, GD, GE, GH, GM, GT, HN, HR, HU, ID, IL, IN, IR, IS, JP, KE, KG, KN, KP, KR, KZ, LA, LC, LK, LR, LS, LU, LY, MA, MD, ME, MG, MK, MN, MW, MX, MY, MZ, NA, NG, NI, NO, NZ, OM, PA, PE, PG, PH, PL, PT, QA, RO, RS, RU, RW, SA, SC, SD, SE, SG, SK, SL, SM, ST, SV, SY, TH, TJ, TM, TN, TR, TT, TZ, UA, UG, US, UZ, VC, VN, ZA, ZM, ZW.

(84) Designated States (unless otherwise indicated, for every kind of regional protection available): ARIPO (BW, GH, GM, KE, LR, LS, MW, MZ, NA, RW, SD, SL, ST, SZ, TZ, UG, ZM, ZW), Eurasian (AM, AZ, BY, KG, KZ, RU, TJ, TM), European (AL, AT, BE, BG, CH, CY, CZ, DE, DK, EE, ES, FI, FR, GB, GR, HR, HU, IE, IS, IT, LT, LU, LV, MC, MK, MT, NL, NO, PL, PT, RO, RS, SE, SI, SK, SM, TR), OAPI (BF, BJ, CF, CG, CI, CM, GA, GN, GQ, GW, KM, ML, MR, NE, SN, TD, TG).

Published:

- with international search report (Art. 21(3))
- with amended claims (Art. 19(1))

(54) Title: WIRELESS POWER TRANSFER USING MULTIPLE COIL ARRAYS

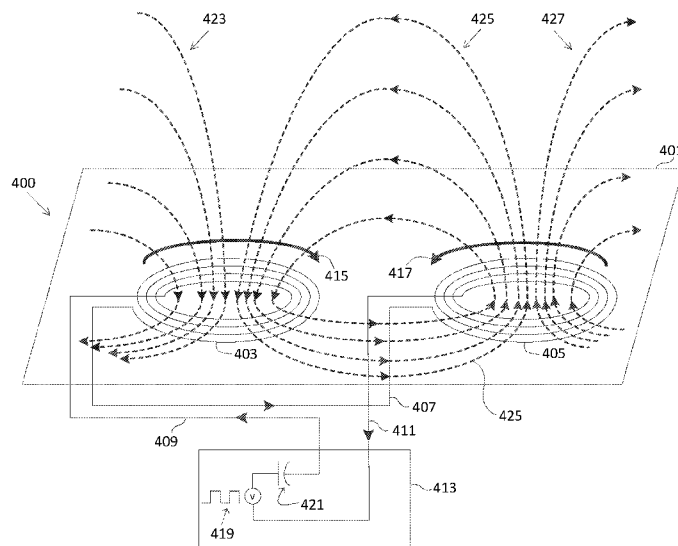

FIG. 4

(57) Abstract: In one embodiment of a wireless power transmitter, two coils are magnetically coupled together by placing both coils on a magnetic layer. A power circuit generates an AC signal of a defined voltage magnitude that causes a current to flow through the first coil, which generates a magnetic field having a first polarity. The second coil is coupled to the first coil. Current flows through the second coil and generates a magnetic field having a second polarity that is opposite from the first polarity. Because the magnetic field generated by each coil has a different polarity, the magnetic fields attract and form a strong magnetic field that flows from the first coil to the second coil. The strong magnetic field can transfer greater amounts of power to a receiver in comparison to coil configurations that emit magnetic fields in the same direction that repel one another.

WO 2016/160681 A1

WIRELESS POWER TRANSFER USING MULTIPLE COIL ARRAYS

CROSS-REFERENCE TO RELATED APPLICATION

[0001] This application claims the benefit of U.S. Provisional Patent Application No. 62/139,785, entitled "Wireless Power Transfer Method Using Multiple Coil Arrays," filed on March 29, 2015. The subject matter of the related application is hereby incorporated by reference in its entirety.

FIELD OF THE INVENTION

[0002] This invention relates generally to wireless power transfer and more specifically to a multiple coil array for wireless power transfer.

BACKGROUND

[0003] Electronic devices typically require a connected (wired) power source to operate, for example, battery power or a wired connection to a direct current ("DC") or alternating current ("AC") power source. Similarly, rechargeable battery-powered electronic devices are charged using a wired power-supply that connects the electronic device to a DC or AC power source. The limitation of these devices is the need to directly connect the device to a power source using wires.

[0004] Wireless power transfer (WPT) involves the use of time-varying magnetic fields to wirelessly transfer power from a source to a device. Faraday's law of magnetic induction provides that if a time-varying current is applied to one coil (e.g., a transmitter coil) a voltage will be induced in a nearby second coil (e.g., a receiver coil). The voltage induced in the receiver coil can then be rectified and filtered to generate a stable DC voltage for powering an electronic device or charging a battery. The receiver coil and associated circuitry for generating a DC voltage can be connected to or included within the electronic device itself such as a smartphone.

[0005] The Wireless Power Consortium (WPC) was established in 2008 to develop the Qi inductive power standard for charging and powering electronic devices. Powermat is another well-known standard for WPT developed by the Power Matters Alliance (PMA). The Qi and Powermat near-field standards operate in the frequency band of 100-400kHz. The problem with near-field WPT technology is that typically only 5 Watts of power can be transferred over the short distance of 2 to 5 millimeters between a power source and an electronic device, though there are ongoing efforts to increase the power. For example, some concurrently developing standards achieve this by operating at much higher

frequencies, such as 6.78 MHz or 13.56 MHz. Though they are called magnetic resonance methods instead of magnetic induction, they are based on the same underlying physics of magnetic induction. There also have been some market consolidation efforts to unite into larger organizations, such as the AirFuel Alliance consisting of PMA and the Rezence standard from the Alliance For Wireless Power (A4WP), but the technical aspects have remained largely unchanged.

[0006] Some techniques for WPT use two or more transmitter coils in an attempt to overcome the issue of low power transfer over short distances. Typically, two identical transmitter coils (e.g., both wound in the clockwise direction or both wound in the counter-clockwise direction and having the same number of turns and area) are coupled in series or parallel on a single magnetic layer to transfer power to a receiver coil. Alternatively, the coils can be placed in close proximity to one another without the use of a magnetic layer. This configuration results in the applied time-varying current flowing through both coils in the same direction at any point in time, generating an almost perpendicular combined magnetic field with flux lines that flow from both coils in the same direction (i.e., the magnetic field generated by either coil has the same polarity as the other coil). Magnetic flux lines tend to repel if they are in the same direction, which causes the flux lines to radiate through the air for great distances. When magnetic flux lines repel, the magnetic reluctance is high, resulting in a weak magnetic field that reduces the amount of magnetic coupling between the transmitter coils and a receiver coil placed in close proximity (i.e., 2-5 millimeters) to the transmitter coils. So although the coil area is larger than in a single-coil transmitter, the resulting magnetic flux available to transfer power is reduced. If the transmitter coils are placed on separate magnetic layers, an air gap exists between the magnetic layers resulting in an even weaker generated magnetic field as the air gap further increases the reluctance between the transmitter coils.

[0007] When multiple transmitter coils are used there is an additional problem with meeting Electromagnetic Interference (EMI) requirements, including, for example, spurious emissions requirements set forth by the Federal Communications Commission (FCC) and the European Telecommunications Standard Institute (ETSI). When magnetic flux lines radiate away from a transmitter coil into the environment, there is a higher likelihood that the emissions will exceed EMI compliance standards. Additionally, flux lines tend to radiate into the atmosphere if a transmitter coil is driven without a receiver coil to receive the

generated flux. To avoid this issue, such multiple coil arrangements require polling the transmitter coils to determine which transmitter coils are providing power to a receiver coil (e.g., smartphone with a receiver coil placed over the transmitter coil) and disabling all other unused transmitter coils. If only a single transmitter coil is used to meet EMI requirements, this implementation will suffer from the same low power and short distance of power transfer issues discussed above.

[0008] Transmitters that comply with existing WPT standards also achieve substantially lower power transfer to an electronic device if the receiver coil in the electronic device is not properly centered over the transmitter coil. One technique used to address this issue is increasing the frequency of the time-varying current applied to the transmitter coil (e.g., frequencies above 400kHz). Although higher frequencies of operation may increase the amount of power transferred over the distance between a transmitter coil and a receiver coil, higher frequencies of operation may interfere with the operation of other devices and may fail EMI compliance requirements by emitting energy in neighboring frequency bands that exceed spurious emission requirements.

[0009] Due to the short range of existing WPT technology, the transmitter coil must be centered with the receiver coil connected to a device and the coils cannot be more than 2-5 millimeters apart. This makes it difficult to implement wireless power transfer for devices that are not perfectly flat or do not have a large enough area for embedding a receiver coil (e.g., Android® wearable devices, Apple® watch, Fitbit® fitness tracker, etc.). The limitations of WPT also affect smartphones if the charging surface with the transmitter coil is not large enough to allow the smartphone device to sit flat on the surface (e.g., in vehicles, which typically do not have a large enough flat surface to accommodate a smartphone device). Thus, the current state of WPT technology is not suitable for many consumer devices.

SUMMARY OF THE INVENTION

[0010] Wireless power transfer using multiple coils configured to generate a strong magnetic field allows for greater amounts of wireless power transfer without exceeding EMI compliance requirements. In one embodiment, two coils are magnetically coupled together by placing both coils on a magnetic layer. A power circuit generates an AC signal that causes a current to flow through the first coil in a first direction and a current to flow through the second coil in a second direction that is opposite from the first direction. The first coil

generates a magnetic field having a first polarity and the second coil generates a magnetic field having a second polarity, where the first polarity is opposite from the second polarity. Because the magnetic field generated by each coil has a different polarity, the magnetic fields attract to form a strong magnetic field that flows from the first coil to the second coil.

[0011] In another embodiment, pairs of coils are magnetically coupled together by placing each pair of coils on a separate magnetic layer (e.g., coils 1 and 2 are on magnetic layer 1, coils 3 and 4 are on magnetic layer 2, etc.). Coils coupled together using the same magnetic layer are configured such that a current flows through each coil in an opposite direction, resulting in each coil generating a magnetic field with opposing polarity. The opposing magnetic fields attract to form strong magnetic fields. The strong magnetic fields generated by each pair of coils do not affect one another because the air gap results in high reluctance between coils on different magnetic layers.

[0012] In another embodiment, four coils are magnetically coupled together by placing the coils on a magnetic layer. The magnetic layer contains an air gap for separating coils that generate magnetic fields with the same polarity. A power circuit generates an AC signal that causes a current to flow through the first coil in a first direction and a current to flow through the second coil in a second direction that is opposite from the first direction. The first coil generates a magnetic field having a first polarity and the second coil generates a second magnetic field having a second polarity that is opposite from the first polarity. The third coil is coupled to the second coil in such a way that a current flows through the third coil in a third direction that is opposite from the second direction. The third coil generates a third magnetic field having a third polarity that is opposed from the second polarity. The fourth coil is coupled to the second coil in such a way that a current flows through the fourth coil in a fourth direction that is opposite from the third direction and the first direction. The fourth coil generates a fourth magnetic field having a fourth polarity that is opposite from the third polarity and the first polarity. Magnetic fields having opposing polarity attract to form strong magnetic fields. Coils that generate magnetic fields having the same polarity are separated by the air gap in the magnetic layer resulting in high reluctance between the coils.

[0013] In another embodiment, two coils are magnetically coupled together by placing both coils on a magnetic layer. A wireless power transmitter emits a magnetic field that couples onto each coil causing a time-varying current to flow through each coil. The

time-varying current flows through each coil to a receive circuit that can include a rectifier to generate a DC voltage, a filter to reduce noise, and a voltage regulator to define a voltage magnitude and maintain the voltage under load.

[0014] In another embodiment, a magnetic layer is not used. Coils that generate magnetic fields having opposite polarity can be placed in close proximity to one another and coils that generate magnetic fields having the same polarity can be placed farther apart from one another.

[0015] In another embodiment, coils that generate magnetic fields having opposite polarity can be placed in such a way that the coils partially overlap.

BRIEF DESCRIPTION OF THE DRAWINGS

[0016] FIG. 1 is a block diagram illustrating one embodiment of a wireless power transmitter.

[0017] FIG. 2 is a schematic diagram illustrating one embodiment of a wireless power transmitter using two coils coupled in series.

[0018] FIG. 3 is a schematic diagram illustrating one embodiment of a wireless power transmitter using two coils coupled in parallel.

[0019] FIG. 4 is a schematic diagram illustrating one embodiment of a wireless power transmitter with magnetic coupling of the flux lines emitted from two coils.

[0020] FIG. 5 is a schematic diagram illustrating one embodiment of a wireless power transmitter with magnetic coupling of the flux lines emitted from pairs of coils on separate magnetic layers.

[0021] FIG. 6 is a schematic diagram illustrating one embodiment of a wireless power transmitter with four coils on the same magnetic layer with an air gap separating coils that generate magnetic fields with the same polarity.

[0022] FIG. 7 is a schematic diagram illustrating one embodiment of a wireless power transmitter with six coils on the same magnetic layer with air gaps separating coils that generate magnetic fields with the same polarity.

[0023] FIG. 8 is a schematic diagram illustrating one embodiment of a wireless power receiver using one coil.

[0024] FIG. 9 is a schematic diagram illustrating one embodiment of a wireless power receiver using two coils.

DETAILED DESCRIPTION

[0025] FIG. 1 is a block diagram illustrating one embodiment of wireless power transmitter 100. A coil 103 and a coil 105 are magnetically coupled together by placing both coils on a magnetic layer 101. Magnetic layer 101 can be ferrite or any other magnetic layer known in the art. Coil 103 and coil 105 are preferably identical coils with the same number of turns, the same area, and wound in the same direction (i.e., clockwise or counter-clockwise). A power circuit 113 generates an AC signal of a defined voltage magnitude. The generated AC signal can be, but is not limited to, a square wave, a sinusoidal wave, a triangular wave, or a sawtooth wave. The AC signal causes current to flow from power circuit 113 to coil 103 through a connection 109. The flow of current through coil 103 generates a magnetic field. The current flows from coil 103 to coil 105 through a connection 107. If coils 103 and 105 are identical, the flow of current through coil 105 generates a magnetic field equivalent in magnitude to the magnetic field generated by coil 103. The current flows from coil 105 to power circuit 113 through a connection 111. Coils 103 and 105 and connections 107, 109 and 111 can be formed of wire or traces on a printed circuit board using conductive material such as copper, gold, or any other conductive material known in the art.

[0026] FIG. 2 is a schematic diagram illustrating one embodiment of a wireless power transmitter 200 using two coils coupled in series. A coil 203 and a coil 205 are magnetically coupled together by placing both coils on a magnetic layer 201. Magnetic layer 201 can be ferrite or any other magnetic layer known in the art. Coil 203 and coil 205 are preferably identical coils with the same number of turns, the same area, and wound in the same direction. Coil 203 and coil 205 are both wound in the clockwise direction but both coils could alternatively be wound in the counter-clockwise direction. A power circuit 213 generates an AC signal 219 of a defined voltage magnitude. AC signal 219 can be, but is not limited to, a square wave, a sinusoidal wave, a triangular wave, or a sawtooth wave.

[0027] Power circuit 213 includes a capacitor 221 to set the resonant frequency of transmitter 200. The resonant frequency of transmitter 200 is a function of the inductance of coil 203 and coil 205, and the capacitance of capacitor 221. Resonant frequency is in general calculated by:

$$F_R = \frac{1}{2\pi\sqrt{L \cdot C}}$$

In the case of coupled coils, a coupled or mutual inductance term causes some deviation from the above general equation, which we are ignoring here for simplicity. For example, if coil 203 has an inductance of $250\mu\text{H}$, coil 205 has an inductance of $250\mu\text{H}$ and capacitor 221 has a capacitance of 5nF , the resonant frequency of transmitter 200 is 100.66 kHz . The preferable resonant frequency range for operating a wireless power transmitter is between $100\text{-}400\text{kHz}$ to reduce the likelihood of exceeding EMI compliance requirements, however, any resonant frequency is within the scope of the invention.

[0028] Power circuit 213 generates AC signal 219, which flows through capacitor 221 to coil 203 through a connection 209. A current 215 flows through coil 203 in the clockwise direction. The clockwise flow of current 215 through coil 203 generates a magnetic field. Current 215 flows from coil 203 to coil 205 through a connection 207 (i.e., coil 203 is coupled in series with coil 205). A current 217 flows through coil 205 in the counter-clockwise direction. Current 215 is equivalent in magnitude to current 217 but flows in the opposite direction. If coils 203 and 205 are identical, the flow of current 215 through coil 203 generates a magnetic field equivalent in magnitude to the magnetic field generated by the flow of current 217 through coil 205. Because current 215 and current 217 are flowing in opposite directions at any given point in time, the magnetic field generated by current 215 is in a different direction than the magnetic field generated by current 217 (i.e., the magnetic fields have different polarity). Current 217 flows from coil 205 to power circuit 213 through a connection 211. Coils 203 and 205 and connections 207, 209 and 211 can be formed of wire or traces on a printed circuit board using conductive material such as copper, gold, or any other conductive material known in the art.

[0029] FIG. 3 is a schematic diagram illustrating one embodiment of a wireless power transmitter 300 using two coils coupled in parallel. A coil 303 and a coil 305 are magnetically coupled together by placing both coils on magnetic layer 301. Magnetic layer 301 can be ferrite or any other magnetic layer known in the art. Coil 303 and coil 305 preferably have the same number of turns and the same area. However, unlike the embodiment of Fig. 2, coil 303 and coil 305 are wound in opposite directions. Although Fig. 3 shows coil 303 as wound in the clockwise direction and coil 305 as wound in the counter-clockwise direction, coil 303 could be wound in the counter-clockwise direction and coil 305 could be wound in the clockwise direction. A power circuit 313 generates an AC signal 319

of a defined voltage magnitude. AC signal 319 can be, but is not limited to, a square wave, a sinusoidal wave, a triangular wave, or a sawtooth wave.

[0030] Similar to the embodiment of Fig. 2, power circuit 313 includes a capacitor 321 to set the resonant frequency of transmitter 300. Power circuit 313 generates AC signal 319, which flows through capacitor 321 to coil 303 through a connection 309 and coil 305 through a connection 307 (i.e., coil 303 is in parallel with coil 305). A current 315 flows through coil 303 in the clockwise direction. The clockwise flow of current 315 through coil 303 generates a magnetic field. A current 317 flows through coil 305 in the counter-clockwise direction. Current 315 is equivalent in magnitude to current 317 but flows in an opposite direction. If coil 303 and coil 305 have the same number of turns and area, the flow of current 317 through coil 305 generates a magnetic field equivalent in magnitude to the magnetic field generated by the flow of current 315 through coil 303. Because current 315 and current 317 are flowing in opposite directions at any given point in time, the magnetic field generated by current 315 is in a different direction than the magnetic field generated by current 317 (i.e., the magnetic fields have different polarity). Current 315 flows from coil 303 to power circuit 313 through a connection 311. Current 317 flows from coil 305 to power circuit 313 through a connection 325. Coils 303 and 305 and connections 307, 309, 311 and 325, can be formed of wire or traces on a printed circuit board using conductive material such as copper, gold, or any other conductive material known in the art.

[0031] FIG. 4 is a schematic diagram illustrating one embodiment of a wireless power transmitter 400 with magnetic coupling of flux lines emitted from two coils. A coil 403 and a coil 405 are magnetically coupled together by placing both coils on a magnetic layer 401. Magnetic layer 401 can be ferrite or any other magnetic layer known in the art. Coil 403 and coil 405 are preferably identical coils with the same number of turns, the same area, and wound in the same direction. Coil 403 and coil 405 are both wound in the clockwise direction but both coils could alternatively be wound in the counter-clockwise direction. A power circuit 413 generates an AC signal 419 of a defined voltage magnitude. AC signal 419 can be, but is not limited to, a square wave, a sinusoidal wave, a triangular wave, or a sawtooth wave.

[0032] Similar to the embodiment of Fig. 2, power circuit 413 includes a capacitor 421 to set the resonant frequency of transmitter 400. Power circuit 413 generates AC signal 419, which flows through capacitor 421 to coil 403 through a connection 409. A current 415

flows through coil 403 in the clockwise direction. The clockwise flow of current 415 through coil 403 generates a magnetic field represented by flux lines 423. Flux lines 423 flow perpendicular to current 415. According to the “right-hand-rule,” the clockwise flow of current 415 through coil 403 causes flux lines 423 to flow in the downward direction. Current 415 flows from coil 403 to coil 405 through a connection 407 (i.e., coil 403 is in series with coil 405). A current 417 flows through coil 405 in the counter-clockwise direction. The counter-clockwise flow of current 417 through coil 405 generates a magnetic field represented by flux lines 427. Flux lines 427 flow perpendicular to current 417. According to the “right-hand-rule,” the counter-clockwise flow of current 417 through coil 405 causes flux lines 427 to flow in the upward direction.

[0033] Current 415 is equivalent in magnitude to current 417 but flows in an opposite direction. If coil 403 and coil 405 are identical, the flow of current 415 through coil 403 generates a magnetic field equivalent in magnitude to the magnetic field generated by the flow of current 417 through coil 405. Because current 415 and current 417 are flowing in opposite directions at any given point in time, the magnetic field generated by current 415 is in a different direction than the magnetic field generated by current 417 (i.e., the magnetic fields have different polarity). Further, because flux lines 423 and flux lines 427 are flowing in opposite directions, the magnetic reluctance between flux lines 423 and flux lines 427 is low, causing flux lines 423 and flux lines 427 to attract to each other. Flux lines 423 and flux lines 427 magnetically couple to form closed flux lines 425. When flux lines close, the amount of flux that radiates in to the atmosphere is reduced, which reduces the amount of EMI radiation and increases the likelihood of meeting EMI compliance requirements. Flux lines 425 form a strong magnetic field that can transfer greater amounts of power to a receiver in comparison to coil configurations that emit flux lines in the same direction that repel one another. Further, flux lines 425 provide a greater area over which WPT can occur. That means a receiver coil does not need to be precisely centered over coils 403 and 405 to enable WPT. However, ensuring that the receiver coil is centered over flux lines 425 will enable greater amounts of power transfer than if the receiver coil is offset from the transmitter coils.

[0034] Current 417 flows from coil 405 to power circuit 413 through a connection 411. Coils 403 and 405 and connections 407, 409 and 411 can be formed of wire or traces

on a printed circuit board using conductive material such as copper, gold, or any other conductive material known in the art.

[0035] Although the embodiment of Fig. 4 has been described with coil 403 and coil 405 coupled in series, the same result can be achieved by coupling coils in parallel as described in the embodiment of Fig. 3. Similar to flux lines 425 of Fig. 4, currents 315 through coil 303 and current 317 through coil 305 in the embodiment of Fig. 3 generate flux lines that flow in opposing directions and magnetically couple, forming a strong magnetic field for WPT to a receiver coil.

[0036] FIG. 5 is a schematic diagram illustrating one embodiment of a wireless power transmitter 500 with magnetic coupling of the flux lines emitted from pairs of coils on separate magnetic layers. A coil 503 and a coil 505 are magnetically coupled together by placing both coils on a magnetic layer 501. Similarly, a coil 523 and a coil 525 are magnetically coupled through a magnetic layer 531 and a coil 543 and a coil 545 are magnetically coupled through a magnetic layer 551. Magnetic layers 501, 531 and 551 are separated by air gaps 559 resulting in high reluctance between coils that are located on different magnetic layers. Magnetic layers 501, 531 and 551 can be ferrite or any other magnetic layer known in the art. Coils coupled together using the same magnetic layer (e.g., coil 503 and coil 505 on magnetic layer 501) are preferably identical coils with the same number of turns, the same area, and wound in the same direction. Coils 503, 505, 523, 525, 543 and 545 are wound in the clockwise direction. Coils coupled together using the same magnetic layer (e.g., coil 503 and coil 505) can alternatively be wound in the counter-clockwise direction. A power circuit 513 generates an AC signal 519 of a defined voltage magnitude. AC signal 519 can be, but is not limited to, a square wave, a sinusoidal wave, a triangular wave, or a sawtooth wave.

[0037] Similar to the embodiment of Fig. 2, power circuit 513 includes a capacitor 521 to set the resonant frequency of transmitter 500. Power circuit 513 generates AC signal 519, which flows through capacitor 521 to coil 503 through a connection 509. A current 515 flows through coil 503 in the clockwise direction. The clockwise flow of current 515 through coil 503 generates a magnetic field that causes flux lines to flow in the downward direction. Current 515 flows from coil 503 to coil 505 through a connection 507 (i.e., coil 503 is in series with coil 505). A current 517 flows through coil 505 in the counter-clockwise direction. The counter-clockwise flow of current 517 through coil 505 generates a magnetic

field that causes flux lines to flow in the upward direction. Because the flux lines from coil 503 and coil 505 flow in opposite directions, the magnetic reluctance is low, and the flux lines magnetically couple together to form closed flux lines 561. As described within the embodiment of Fig. 4, flux lines that magnetically couple form a strong magnetic field that can transfer greater amounts of power to a receiver coil.

[0038] Coil 525 and coil 523 are coupled together through magnetic layer 531. AC signal 519 flows from coil 505 to coil 525 through a connection 511. A current 537 flows through coil 525 in the clockwise direction, which generates a magnetic field that causes flux lines to flow in the downward direction. AC signal 519 flows from coil 525 to coil 523 through a connection 527. A current 535 flows through coil 523 in the counter-clockwise direction, which generates a magnetic field that causes flux lines to flow in the upward direction. Because flux lines from coil 523 and coil 535 flow in opposite directions, the magnetic reluctance is low, and the flux lines magnetically couple together to form closed flux lines 571.

[0039] Coil 543 and coil 545 are coupled together through magnetic layer 551. AC signal 519 flows from coil 523 to coil 545 through connection 541. A current 557 flows through coil 545 in the clockwise direction, which generates a magnetic field that causes flux lines to flow in the downward direction. AC signal 519 flows from coil 545 to coil 543 through a connection 547. A current 555 flows through coil 543 in the counter-clockwise direction, which generates a magnetic field that causes flux lines to flow in the upward direction. Because flux lines from coil 543 and coil 545 flow in opposite directions, the magnetic reluctance is low, and the flux lines magnetically couple together to form closed flux lines 581.

[0040] Current 555 flows from coil 543 to power circuit 513 through a connection 557. Although current 535 through coil 523 and current 555 through coil 543 both flow in the counter-clockwise direction, the flux lines emitted by these coils will not interfere with the magnetic coupling of closed flux lines 571 or 581 because these coils are on different magnetic layers 531 and 551 and are separated by air gaps 559. The same is true for coil 525 and coil 545.

[0041] The embodiment of Fig. 5 has been described with coils 503, 505, 523, 525, 543 and 545 coupled in series. The same result of closed flux lines can be achieved by coupling coils in parallel as described in the embodiment of Fig. 3. For example, coils

coupled together using the same magnetic layer (e.g., coil 503 and coil 505 on magnetic layer 501) would be wound in opposite directions and connected in parallel. The embodiment of Fig. 5 can further be expanded by adding coil pairs that generate strong magnetic fields, where each additional coil pair is on a separate magnetic material.

[0042] FIG. 6 is a schematic diagram illustrating one embodiment of a wireless power transmitter 600 with four coils on the same magnetic layer and an air gap separating coils that generate magnetic fields with the same polarity. Coils 603, 605, 623 and 625 are placed on a magnetic layer 601. A power circuit 613 generates an AC signal 619 of a defined voltage magnitude. AC signal 619 can be, but is not limited to, a square wave, a sinusoidal wave, a triangular wave, or a sawtooth wave. Similar to the embodiment of Fig. 2, power circuit 613 includes a capacitor 621 to set the resonant frequency of transmitter 600.

[0043] Power circuit 613 generates AC signal 619, which flows through capacitor 621 to coil 603 through a connection 609. A current 615 flows through coil 603 in the clockwise direction, which generates a magnetic field that causes flux lines (not shown) to flow in the downward direction. AC signal 619 flows from coil 603 to coil 605 through a connection 607. A current 617 flows through coil 605 in the counter-clockwise direction, which generates a magnetic field that causes flux lines (not shown) to flow in the upward direction. Because flux lines from coil 603 and coil 605 flow in opposite directions, the magnetic reluctance is low, and the flux lines magnetically couple together to form closed flux lines (not shown) that are connected between coil 603 and coil 605, creating a strong magnetic field.

[0044] AC signal 619 flows from coil 605 to coil 625 through a connection 617. A current 637 flows through coil 625 in the clockwise direction, which generates a magnetic field that causes flux lines (not shown) to flow in the downward direction. Because flux lines from coil 605 and coil 625 are flowing in opposite directions, the magnetic reluctance is low, and the flux lines magnetically couple together to form closed flux lines (not shown) that are connected between coil 605 and coil 625 and create a strong magnetic field.

[0045] AC signal 619 flows from coil 625 to coil 623 through a connection 627. A current 635 flows through coil 623 in the counter-clockwise direction, which generates a magnetic field that causes flux lines (not shown) to flow in the upward direction. Because flux lines from coil 623 and coil 635 are flowing in opposite directions, the magnetic reluctance is low, and the flux lines magnetically couple together to form closed flux lines

(not shown) that are connected between coil 625 and coil 623 and create a strong magnetic field. Similarly, flux lines from coil 623 and coil 603 magnetically couple together to form closed flux lines (not shown) that are connected between coil 623 and coil 603 because the flux lines from coil 623 and coil 603 are flowing in opposite directions.

[0046] Current 635 flows from coil 633 to power circuit 613 through a connection 657. Although current 635 through coil 623 and current 617 through coil 605 both flow in the counter-clockwise direction (i.e., the magnetic field generated by current 635 through coil 623 and the magnetic field generated by current 617 through coil 605 have the same polarity), the flux lines emitted by these coils will not affect magnetic coupling of flux lines between coils 603 and 605, coils 605 and 625, coils 625 and 623, and coils 623 and 603. Coil 623 and coil 605 are not adjacent to one another, and instead, are separated by an air gap 659 in magnetic layer 601, which results in high reluctance between the flux lines of coil 605 and coil 623. The same is true for coil 603 and coil 625. In contrast, coils that generate magnetic fields with opposite polarity are arranged adjacent to one another (e.g., coils 603 and 605, coils 605 and 625, coils 625 and 623, and coils 623 and 607) and are not separated by air gap 659, resulting in low reluctance between the coils and coupling of the magnetic fields creating strong magnetic fields.

[0047] The embodiment of Fig. 6 has been described with coils 603, 605, 623 and 625 coupled in series. The same result of closed flux lines can be achieved by coupling coils in parallel as described in the embodiment of Fig. 3. For example, coil 603 (wound in the clockwise direction) could be connected in parallel with coil 605 (wound in the counter-clockwise direction) and coil 623 (wound in the counter-clockwise direction) could be connected in parallel with coil 625 (wound in the clockwise direction). Alternatively, coil 605 (wound in the counter-clockwise direction) could be connected in parallel with coil 625 (wound in the clockwise direction) and coil 623 (wound in the counter-clockwise direction) could be connected in parallel with coil 603 (wound in the clockwise direction).

[0048] FIG. 7 is a schematic diagram illustrating one embodiment of a wireless power transmitter 700 with six coils on the same magnetic layer with air gaps separating coils that generate magnetic fields with the same polarity. Coils 703, 707, 711, 723, 727 and 731 are placed on a magnetic layer 701. A power circuit 715 generates an AC signal 719 of a defined voltage magnitude. AC signal 719 can be, but is not limited to, a square wave, a sinusoidal wave, a triangular wave, or a sawtooth wave. Similar to the embodiment of Fig.

2, power circuit 715 includes a capacitor 721 to set the resonant frequency of transmitter 700.

[0049] Power circuit 715 generates AC signal 719, which flows through capacitor 721 to coil 703 through a connection 741. A current 705 flows through coil 703 in the clockwise direction, which generates a magnetic field that causes flux lines (not shown) to flow in the downward direction. AC signal 719 flows from coil 703 to coil 707 through a connection 743. A current 709 flows through coil 707 in the counter-clockwise direction, which generates a magnetic field that causes flux lines (not shown) to flow in the upward direction. Because flux lines from coil 703 and coil 707 are flowing in opposite directions, the magnetic reluctance is low, and the flux lines magnetically couple together to form closed flux lines (not shown) that are connected between coil 703 and coil 707 and create a strong magnetic field.

[0050] AC signal 719 flows from coil 707 to coil 711 through a connection 745. A current 713 flows through coil 711 in the clockwise direction, which generates a magnetic field that causes flux lines (not shown) to flow in the downward direction. Because flux lines from coil 707 and coil 711 are flowing in opposite directions, the magnetic reluctance is low, and the flux lines magnetically couple together to form closed flux lines (not shown) that are connected between coil 707 and coil 711 and create a strong magnetic field.

[0051] AC signal 719 flows from coil 711 to coil 731 through a connection 747. A current 733 flows through coil 731 in the counter-clockwise direction, which generates a magnetic field that causes flux lines (not shown) to flow in the upward direction. Because flux lines from coil 711 and coil 731 are flowing in opposite directions, the magnetic reluctance is low, and the flux lines magnetically couple together to form closed flux lines (not shown) that are connected between coil 711 and coil 731 and create a strong magnetic field.

[0052] AC signal 719 flows from coil 731 to coil 727 through a connection 749. A current 729 flows through coil 727 in the clockwise direction, which generates a magnetic field that causes flux lines (not shown) to flow in the downward direction. Because flux lines from coil 731 and coil 727 are flowing in opposite directions, the magnetic reluctance is low, and the flux lines magnetically couple together to form closed flux lines (not shown) that are connected between coil 731 and coil 727 and create a strong magnetic field.

[0053] AC signal 719 flows from coil 727 to coil 723 through a connection 751. A current 725 flows through coil 727 in the counter-clockwise direction, which generates a magnetic field that causes flux lines (not shown) to flow in the upward direction. Because flux lines from coil 727 and coil 723 are flowing in opposite directions, the magnetic reluctance is low, and the flux lines magnetically couple together to form closed flux lines (not shown) that are connected between coil 727 and coil 723 and create a strong magnetic field. Similarly, flux lines from coil 723 and coil 703 magnetically couple together to form closed flux lines (not shown) that are connected between coil 723 and coil 703 because the flux lines from coil 723 and coil 703 are flowing in opposite directions.

[0054] Current 725 flows from coil 723 to power circuit 715 through a connection 753. Although current 725 through coil 723 and current 709 through coil 707 both flow in the counter-clockwise direction (i.e., the magnetic field generated by current 725 flowing through coil 723 and the magnetic field generated by current 709 flowing through coil 707 have the same polarity), the flux lines emitted by these coils will not affect magnetic coupling of flux lines between coils 703 and 707, coils 707 and 711, coils 711 and 731, coils 731 and 727, coils 727 and 723, and coils 723 and 703. Coil 723 and coil 707 are not adjacent to one another, and instead, are separated by air gap 759a in magnetic layer 701, which results in high reluctance between the flux lines of coil 723 and coil 707. The same is true for coils 703 and 727, which are separated by air gap 759a, coils 727 and 711, which are separated by air gap 759b, and coils 707 and 731, which are separated by air gap 759b. In contrast, coils that generate magnetic fields with opposite polarity are arranged adjacent to one another (e.g., coils 703 and 707, coils 707 and 711, coils 711 and 731, coils 731 and 727, coils 727 and 723, and coils 723 and 703) and are not separated by air gaps 759a or 759b, resulting in low reluctance and coupling of the magnetic fields creating strong magnetic fields.

[0055] The embodiment of Fig. 7 has been described with coils 703, 707, 711, 731, 727 and 723 coupled in series. The same result of closed flux lines can be achieved by coupling coils in parallel as described in the embodiment of Fig. 3. For example, coil 703 (wound in the clockwise direction) could be connected in parallel with both coil 707 (wound in the counter-clockwise direction) and coil 711 (wound in the clockwise direction). Further, coil 723 (wound in the counter-clockwise direction) could be connected in parallel with both coil 727 (wound in the clockwise direction) and coil 731 (wound in the counter-clockwise

direction). Alternatively, coil 723 (wound in the counter-clockwise direction) could be connected in parallel with coil 703 (wound in the clockwise direction), coil 727 (wound in the clockwise direction) could be connected in parallel with coil 707 (wound in the counter-clockwise direction), and coil 731 (wound in the counter-clockwise direction) could be connected in parallel with coil 711 (wound in the clockwise direction). The embodiment of Fig. 7 can further be expanded by adding additional coils and air gaps, where coils that generate magnetic fields with opposite polarity are adjacent to one another and coils that generate magnetic fields with the same polarity are separated by an air gap.

[0056] The transmitters of FIGs. 1-7 are capable of being used in conjunction with any type of receiver coil, including receivers with multiple coils. The transmitters of FIGs. 1-7 can also be configured as receivers since good transmitters are good receivers just as good antennas for transmission are good antennas for reception.

[0057] FIG. 8 is a schematic diagram illustrating one embodiment of a wireless power receiver 800 using a single coil. A coil 803 is placed on a magnetic layer 801. Magnetic layer 801 can be ferrite or any other magnetic layer known in the art. Coil 803 is wound in the clockwise direction but could alternatively be wound in the counter-clockwise direction.

[0058] A wireless power transmitter 810 (similar to the embodiment of FIG. 4) is driven by a power circuit resulting in each coil emitting a magnetic field. A time-varying current flows through each coil of transmitter 810 in an opposite direction, which causes each coil to generate a magnetic field with opposite polarity. Because the magnetic fields have opposite polarity, the magnetic fields attract and form a strong magnetic field, represented by flux lines 825. The strong magnetic field magnetically couples to coil 803 and a time-varying current flows through coil 803 to a receive circuit 813. Faraday's law provides that the time-varying current that flows in a receiver coil will oppose the magnetic field generated by a transmitter coil. Wireless power transmitter 810 uses two coils, each coil having a time-varying current that flows in an opposite direction. Thus, the direction of the time-varying current that flows in coil 803 will be opposite from the time-varying current that flows in the transmitter coil that is closest to coil 803. Receive circuit 813 can include, but is not limited to, a rectifier to generate a DC voltage, a filter to reduce noise, and a voltage regulator to define a voltage magnitude and maintain the voltage under load. The voltage generated as a result of the coupling of flux lines 825 to coil 803 can be used to

charge a battery or power a device (e.g., a smart phone, laptop or any other electronic device).

[0059] FIG. 9 is a schematic diagram illustrating one embodiment of a wireless power receiver 900 using two coils. A coil 903 and a coil 905 are placed on a magnetic layer 901. Magnetic layer 901 can be ferrite or any other magnetic layer known in the art. Coil 903 and coil 905 are preferably identical coils with the same number of turns, the same area, and wound in the same direction. Coil 903 and coil 905 are both wound in the clockwise direction but both coils could alternatively be wound in the counter-clockwise direction.

[0060] A wireless power transmitter 910 (similar to the embodiment of FIG. 4) is driven by a power circuit resulting in each coil emitting a magnetic field. A time-varying current flows through each coil of transmitter 910 in an opposite direction, which causes each coil to generate a magnetic field with opposite polarity. Because the magnetic fields have opposite polarity, the magnetic fields attract and form a strong magnetic field, represented by flux lines 925. The strong magnetic field magnetically couples to coil 903 and coil 905 and a time-varying current flows through coil 903 and coil 905 to a receive circuit 913. Faraday's law provides that the time-varying current that flows in a receiver coil will oppose the magnetic field generated by a transmitter coil. Wireless power transmitter 810 uses two coils, each coil having a time-varying current that flows in an opposite direction. Thus, the direction of the time-varying current that flows in coil 903 will be opposite from the time-varying current that flows in the transmitter coil that is closest to coil 903 (i.e., the transmitter coil below coil 903). Further, the time-varying current that flows in coil 905 is in an opposite direction than the time-varying current that flows in coil 903 and in an opposite direction than the time-varying current that flows in the transmitter coil closest to coil 905 (i.e., the transmitter coil below coil 905). Receive circuit 913 can include, but is not limited to, a rectifier to generate a DC voltage, a filter to reduce noise, and a voltage regulator to define a voltage magnitude and maintain the voltage under load. The voltage generated as a result of the coupling of flux lines 825 to coil 803 can be used to charge a battery or power a device (e.g., a smart phone, laptop or any other electronic device).

[0061] The embodiments of Figures 1-9 describe the use of a magnetic layer to magnetically couple coils, but magnetic coupling between coils that generate magnetic

fields having opposite polarity can also be achieved without the use of a magnetic layer. The coils can simply be placed in close physical proximity to one another, which is also sufficient to allow magnetic coupling. Without the use of a magnetic layer, coils that generate magnetic fields having the same polarity can be placed farther apart from one another (i.e., large air gap between the coils) such that coils generating magnetic fields with the same polarity do not interfere with the magnetic coupling of coils generating magnetic fields having opposite polarity.

[0062] Further, in all embodiments, coils that generate magnetic fields having opposite polarity can be placed adjacent to one other, or can be placed close enough to one another such that the coils partially overlap. For example, in the context of two coils, the outer edge of one coil can pass through the geometric center of the other coil, and vice versa. Similarly, the first coil and the second coil can be separated by a distance that is approximately equal to five times the diameter of the coils. These dimensions are not intended to be limiting as the use of different types of coils (i.e., coils having different number of turns, shapes, etc.) and different materials for the magnetic layer, among other factors, may allow for more overlap or larger separation between the coils.

[0063] The invention has been described above with reference to specific embodiments. It will, however, be evident that various modifications and changes may be made thereto without departing from the broader spirit and scope of the invention as set forth in the appended claims. The foregoing description and drawings are, accordingly, to be regarded in an illustrative rather than a restrictive sense.

What is claimed is:

1. A wireless power device comprising:
a first coil configured to receive a time-varying current that flows in the first coil in a first direction; and
a second coil coupled to the first coil in such a way that the time-varying current flows in the second coil in a second direction, wherein the first direction is opposite from the second direction, and the first coil is configured to magnetically couple with the second coil.
2. The wireless power device of claim 1, further comprising a magnetic layer configured to magnetically couple the first coil with the second coil.
3. The wireless power device of claim 1, wherein the first coil is configured to magnetically couple with the second coil by being located in close physical proximity to the second coil.
4. The wireless power device of claim 1, wherein the first coil is coupled in series with the second coil.
5. The wireless power device of claim 1, wherein the first coil is coupled in parallel with the second coil.
6. The wireless power device of claim 1, wherein the first coil and the second coil have an equal number of turns, substantially the same shape, and substantially the same area.
7. The wireless power device of claim 1, further comprising a power source configured to generate the time-varying current, wherein the first coil is configured to receive the time-varying current from the power source.
8. The wireless power device of claim 7, further comprising a capacitor coupled between the power source and the first coil.

9. The wireless power device of claim 1, further comprising a receive circuit coupled to the first coil and the second coil, wherein the receive circuit is configured to generate a voltage from the time-varying current that flows in the first coil and the second coil.
10. The wireless power device of claim 2, further comprising:
a third coil configured to receive a second time-varying current that flows in the third coil in a third direction;
a fourth coil coupled to the third coil in such a way that the second time-varying current flows in the fourth coil in a fourth direction, wherein the third direction is opposite from the fourth direction;
a second magnetic layer configured to magnetically couple the third coil and the fourth coil; and
an air gap separating the first magnetic layer from the second magnetic layer.
11. The wireless power device of claim 10, wherein the third coil is coupled in series with the fourth coil.
12. The wireless power device of claim 10, wherein the third coil is coupled in parallel with the fourth coil.
13. The wireless power device of claim 10, wherein the third coil and the fourth coil have an equal number of turns, substantially the same shape, and substantially the same area.
14. The wireless power device of claim 10, further comprising a power source configured to generate the second time-varying current and the third coil is configured to receive the second time-varying current from the power source.
15. The wireless power device of claim 10, wherein the third coil is coupled to the second coil in such a way that the first time-varying current that flows in the second coil is the same direction as the second time-varying current that flows in the third coil.
16. A wireless power device comprising:

a power source configured to generate a first time-varying current;

a first coil configured to receive the first time-varying current from the power source, wherein the first time-varying current flows in the first coil in a first direction;

a second coil coupled to the first coil in such a way that the first time-varying current flows in the second coil in a second direction, wherein the first direction is opposite from the second direction;

a third coil configured to receive a second time-varying current, wherein the time varying current flows in the third coil in a third direction and the third direction is opposite from the second direction;

a fourth coil coupled to the third coil in such a way that the second time-varying current flows in the fourth coil in a fourth direction, wherein the fourth direction is opposite from the third direction and the first direction;

a magnetic layer configured to magnetically couple the first coil and the second coil, and to magnetically couple the third coil and the fourth coil; and

an air gap in the magnetic layer, wherein the air gap separates the first coil from the third coil and the second coil from the fourth coil.

17. The wireless power device of claim 16, wherein the first coil is coupled in series with the second coil.

18. The wireless power device of claim 16, wherein the first coil is coupled in parallel with the second coil.

19. The wireless power device of claim 16, wherein the third coil is coupled in series with the fourth coil.

20. The wireless power device of claim 16, wherein the third coil is coupled in parallel with the fourth coil.

21. The wireless power device of claim 16, wherein the first coil and the second coil have an equal number of turns, substantially the same shape, and substantially the same area.

22. The wireless power device of claim 16, wherein the third coil and the fourth coil have an equal number of turns, substantially the same shape, and substantially the same area.

23. The wireless power device of claim 16, wherein the power source is configured to generate the second time-varying current and the third coil is configured to receive the second time-varying current from the power source.

24. The wireless power device of claim 16, wherein the third coil is coupled to the second coil in such a way that the first time-varying current that flows in the second coil is the same as the second time-varying current that flows in the third coil.

25. The wireless power device of claim 16, further comprising a capacitor coupled between the first coil and the power source.

26. A wireless power device comprising:

- a first coil wound in a first direction such that the first coil is configured to generate a first magnetic field having a first polarity; and
- a second coil coupled to the first coil, wherein the second coil is wound in a second direction and is configured to generate a second magnetic field having a second polarity, wherein the first polarity is opposite from the second polarity, and the first coil is configured to magnetically couple with the second coil.

27. The wireless power device of claim 26, further comprising a magnetic layer configured to magnetically couple the first coil with the second coil.

28. The wireless power device of claim 26, wherein the first coil is configured to magnetically couple with the second coil being located in close physical proximity with the second coil.

29. The wireless power device of claim 26, wherein the first coil is coupled in series with the second coil.

30. The wireless power device of claim 26, wherein the first coil is coupled in parallel with the second coil.

31. The wireless power device of claim 26, wherein the first coil and the second coil have an equal number of turns, substantially the same shape, and substantially the same area.

32. The wireless power device of claim 26, further comprising a power source coupled to the first coil, the power source configured to generate a time-varying current.

33. The wireless power device of claim 32, further comprising a capacitor coupled between the power source and the first coil.

34. The wireless power device of claim 26, further comprising a receive circuit coupled to the first coil and the second coil, wherein the receive circuit is configured to generate a voltage from a time-varying current flowing in the first coil and the second coil..

AMENDED CLAIMS

received by the International Bureau on 23 August 2016 (23.08.2016)

1. A wireless power device comprising:
a first coil configured to receive a time-varying current that flows in the first coil in a first direction;
a second coil coupled to the first coil in such a way that the time-varying current flows in the second coil in a second direction, wherein the first direction is opposite from the second direction, and the first coil is configured to magnetically couple with the second coil; and
a magnetic layer configured to magnetically couple the first coil with the second coil, wherein an axis of the first coil is normal to a surface of the magnetic layer and an axis of the second coil is normal to the surface of the magnetic layer.
2. Canceled.
3. The wireless power device of claim 1, wherein the first coil is configured to magnetically couple with the second coil by being located in close physical proximity to the second coil.
4. The wireless power device of claim 1, wherein the first coil is coupled in series with the second coil.
5. The wireless power device of claim 1, wherein the first coil is coupled in parallel with the second coil.
6. The wireless power device of claim 1, wherein the first coil and the second coil have an equal number of turns, substantially the same shape, and substantially the same area.
7. The wireless power device of claim 1, further comprising a power source configured to generate the time-varying current, wherein the first coil is configured to receive the time-varying current from the power source.

8. The wireless power device of claim 7, further comprising a capacitor coupled between the power source and the first coil.
9. The wireless power device of claim 1, further comprising a receive circuit coupled to the first coil and the second coil, wherein the receive circuit is configured to generate a voltage from the time-varying current that flows in the first coil and the second coil.
10. The wireless power device of claim 1, further comprising:
 - a third coil configured to receive a second time-varying current that flows in the third coil in a third direction;
 - a fourth coil coupled to the third coil in such a way that the second time-varying current flows in the fourth coil in a fourth direction, wherein the third direction is opposite from the fourth direction;
 - a second magnetic layer configured to magnetically couple the third coil and the fourth coil; and
 - an air gap separating the first magnetic layer from the second magnetic layer.
11. The wireless power device of claim 10, wherein the third coil is coupled in series with the fourth coil.
12. The wireless power device of claim 10, wherein the third coil is coupled in parallel with the fourth coil.
13. The wireless power device of claim 10, wherein the third coil and the fourth coil have an equal number of turns, substantially the same shape, and substantially the same area.
14. The wireless power device of claim 10, further comprising a power source configured to generate the second time-varying current and the third coil is configured to receive the second time-varying current from the power source.

15. The wireless power device of claim 10, wherein the third coil is coupled to the second coil in such a way that the first time-varying current that flows in the second coil is the same direction as the second time-varying current that flows in the third coil.
16. A wireless power device comprising:
a power source configured to generate a first time-varying current;
a first coil configured to receive the first time-varying current from the power source, wherein the first time-varying current flows in the first coil in a first direction;
a second coil coupled to the first coil in such a way that the first time-varying current flows in the second coil in a second direction, wherein the first direction is opposite from the second direction;
a third coil configured to receive a second time-varying current, wherein the time varying current flows in the third coil in a third direction and the third direction is opposite from the second direction;
a fourth coil coupled to the third coil in such a way that the second time-varying current flows in the fourth coil in a fourth direction, wherein the fourth direction is opposite from the third direction and the first direction;
a magnetic layer configured to magnetically couple the first coil and the second coil, and to magnetically couple the third coil and the fourth coil; and
an air gap in the magnetic layer, wherein the air gap separates the first coil from the third coil and the second coil from the fourth coil,
wherein an axis of the first coil is normal to a surface of the magnetic layer and an axis of the second coil is normal to the surface of the magnetic layer.
17. The wireless power device of claim 16, wherein the first coil is coupled in series with the second coil.
18. The wireless power device of claim 16, wherein the first coil is coupled in parallel with the second coil.

19. The wireless power device of claim 16, wherein the third coil is coupled in series with the fourth coil.
20. The wireless power device of claim 16, wherein the third coil is coupled in parallel with the fourth coil.
21. The wireless power device of claim 16, wherein the first coil and the second coil have an equal number of turns, substantially the same shape, and substantially the same area.
22. The wireless power device of claim 16, wherein the third coil and the fourth coil have an equal number of turns, substantially the same shape, and substantially the same area.
23. The wireless power device of claim 16, wherein the power source is configured to generate the second time-varying current and the third coil is configured to receive the second time-varying current from the power source.
24. The wireless power device of claim 16, wherein the third coil is coupled to the second coil in such a way that the first time-varying current that flows in the second coil is the same as the second time-varying current that flows in the third coil.
25. The wireless power device of claim 16, further comprising a capacitor coupled between the first coil and the power source.
26. A wireless power device comprising:
- a first coil wound in a first direction such that the first coil is configured to generate a first magnetic field having a first polarity;
 - a second coil coupled to the first coil, wherein the second coil is wound in a second direction and is configured to generate a second magnetic field having a second polarity, wherein the first polarity is opposite from the second polarity, and the first coil is configured to magnetically couple with the second coil; and

a magnetic layer configured to magnetically couple the first coil with the second coil, the magnetic layer having a surface perpendicular to an axis of the first coil and an axis of the second coil.

27. Canceled.

28. The wireless power device of claim 26, wherein the first coil is configured to magnetically couple with the second coil by being located in close physical proximity with the second coil.

29. The wireless power device of claim 26, wherein the first coil is coupled in series with the second coil.

30. The wireless power device of claim 26, wherein the first coil is coupled in parallel with the second coil.

31. The wireless power device of claim 26, wherein the first coil and the second coil have an equal number of turns, substantially the same shape, and substantially the same area.

32. The wireless power device of claim 26, further comprising a power source coupled to the first coil, the power source configured to generate a time-varying current.

33. The wireless power device of claim 32, further comprising a capacitor coupled between the power source and the first coil.

34. The wireless power device of claim 26, further comprising a receive circuit coupled to the first coil and the second coil, wherein the receive circuit is configured to generate a voltage from a time-varying current flowing in the first coil and the second coil.

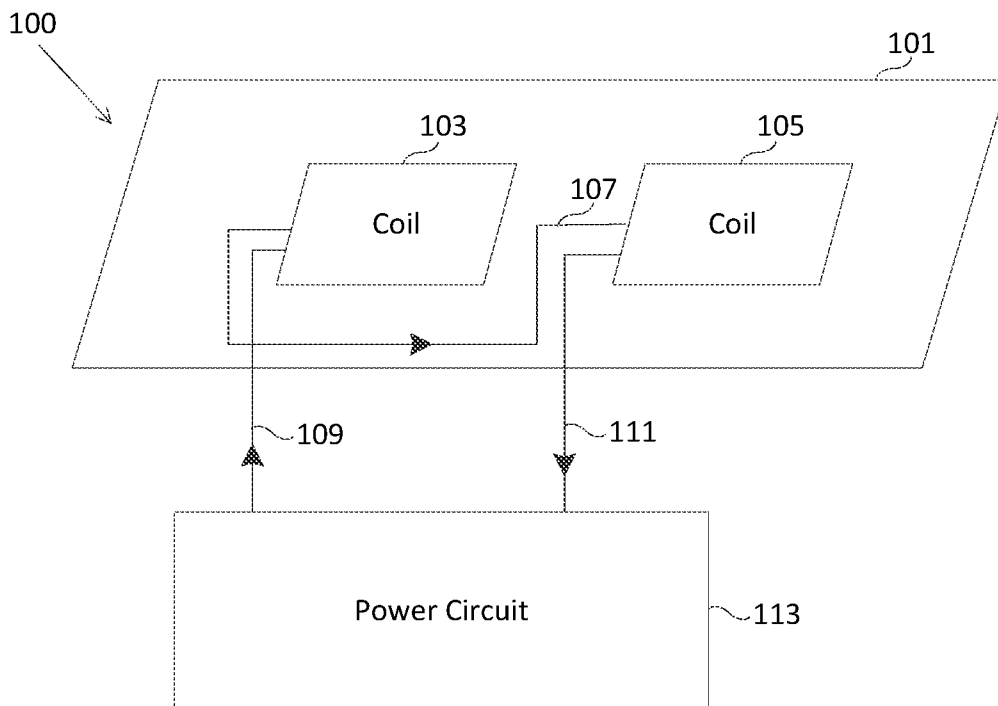

FIG. 1

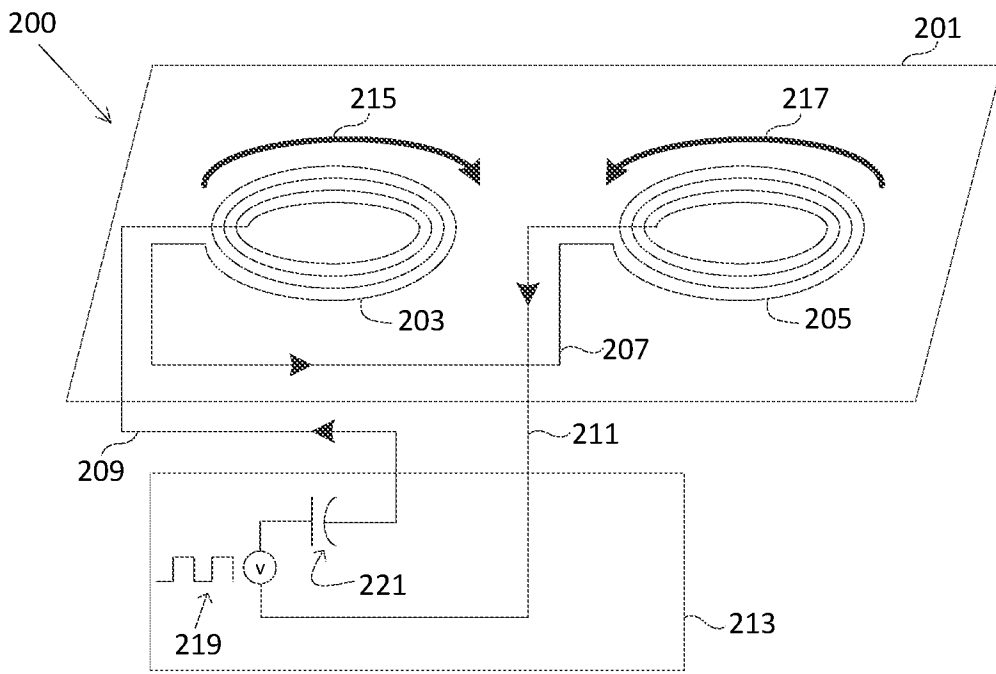

FIG. 2

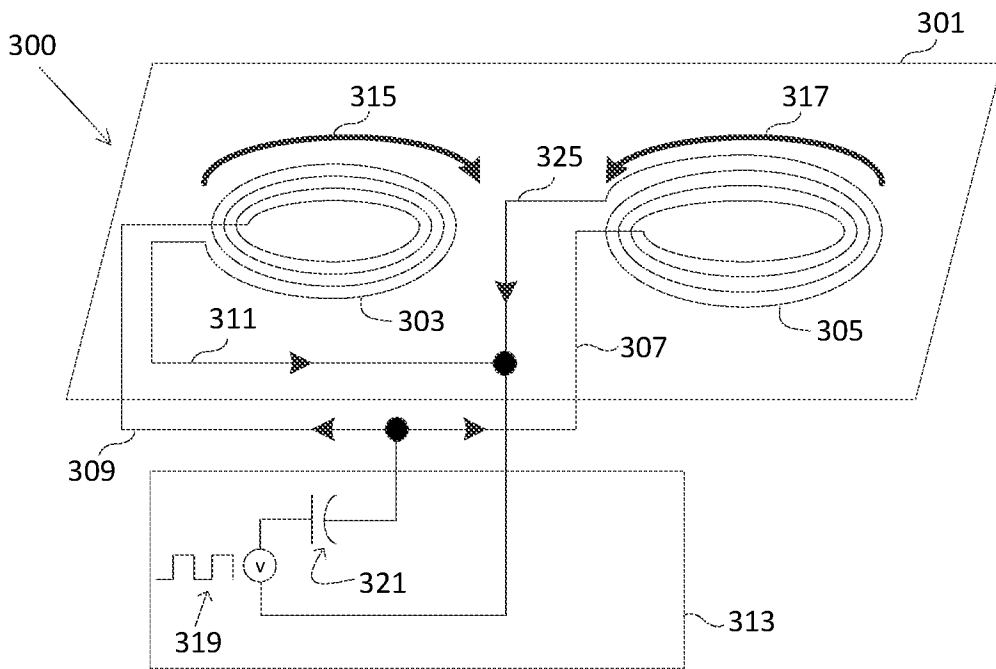

FIG. 3

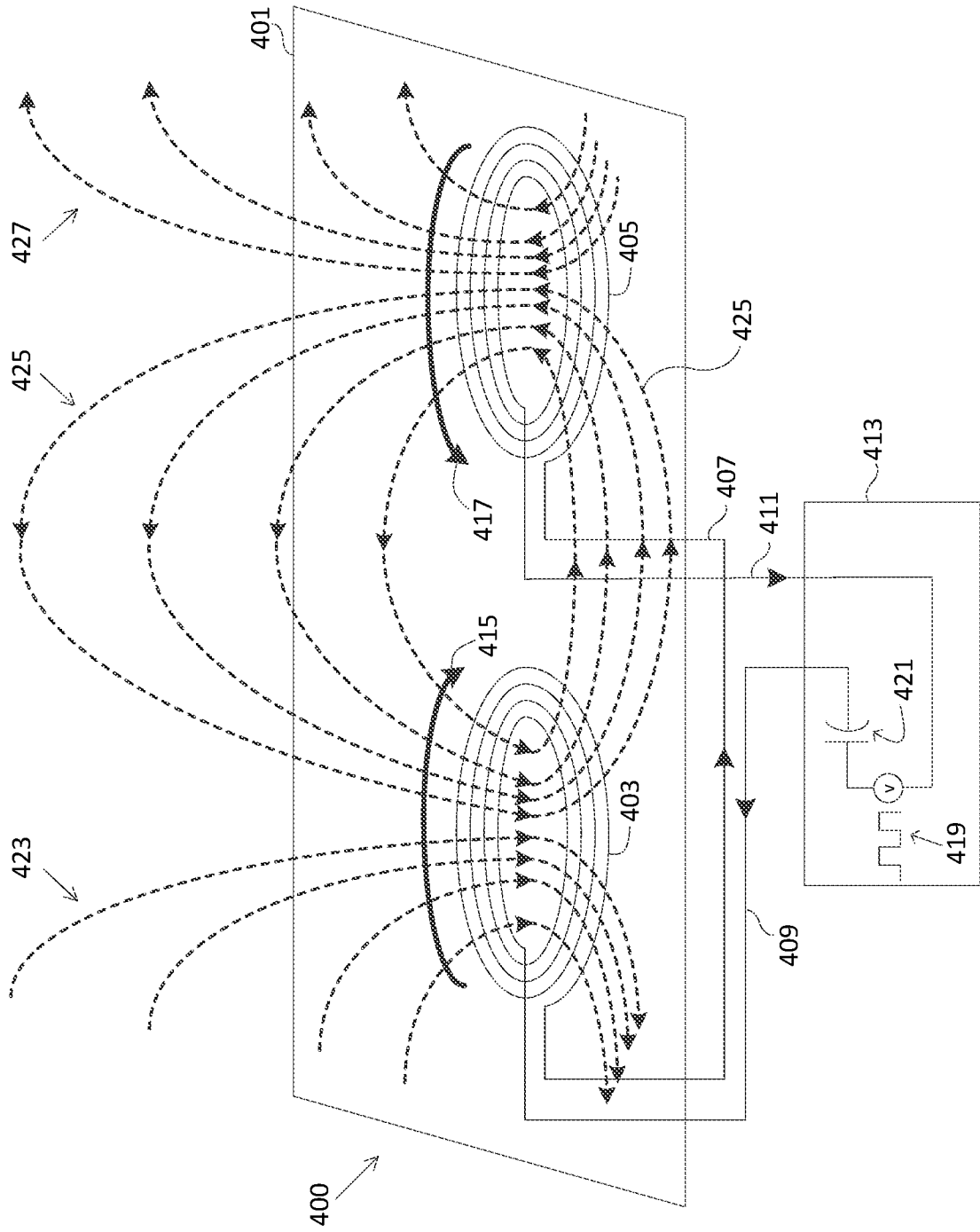

FIG. 4

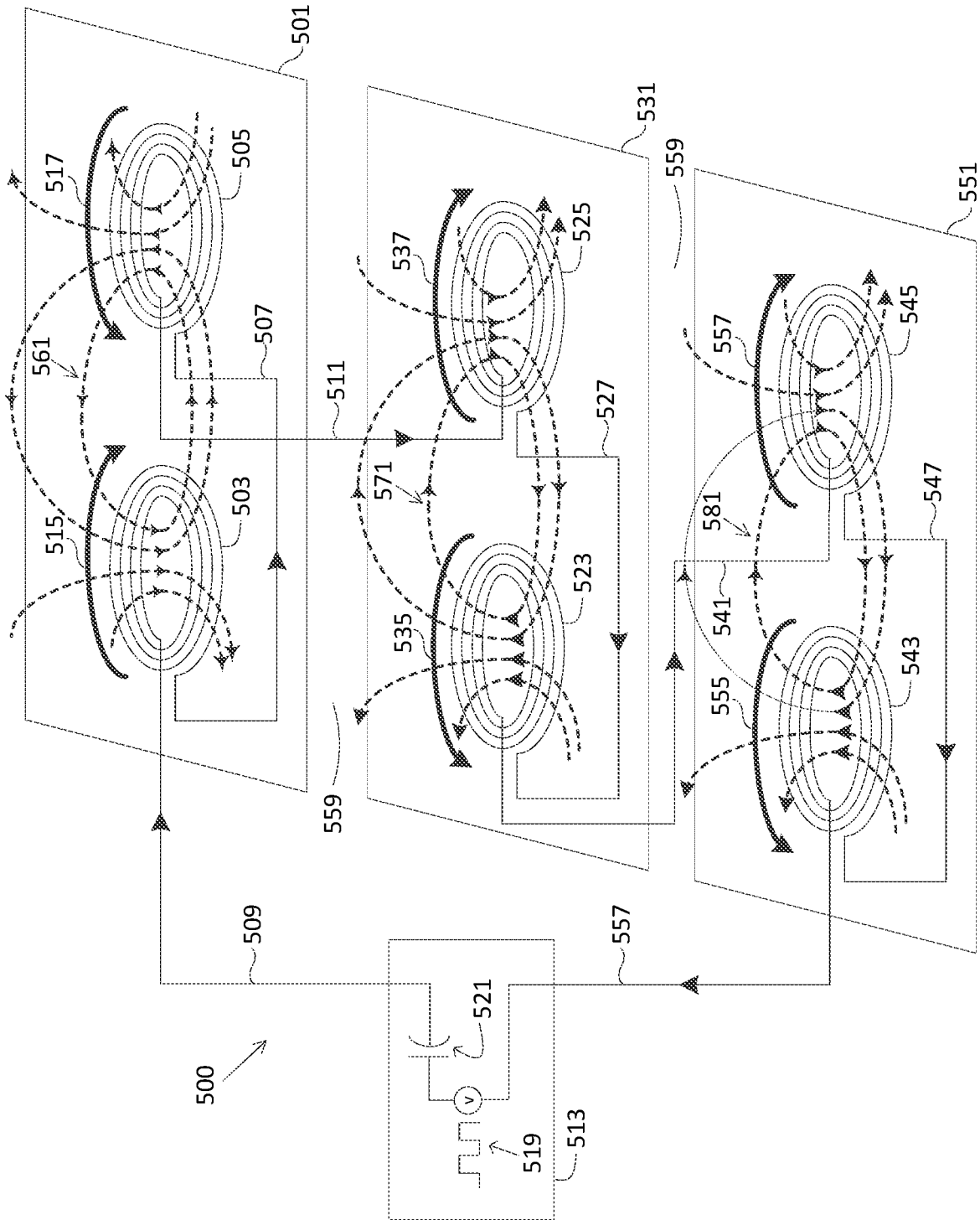

FIG. 5

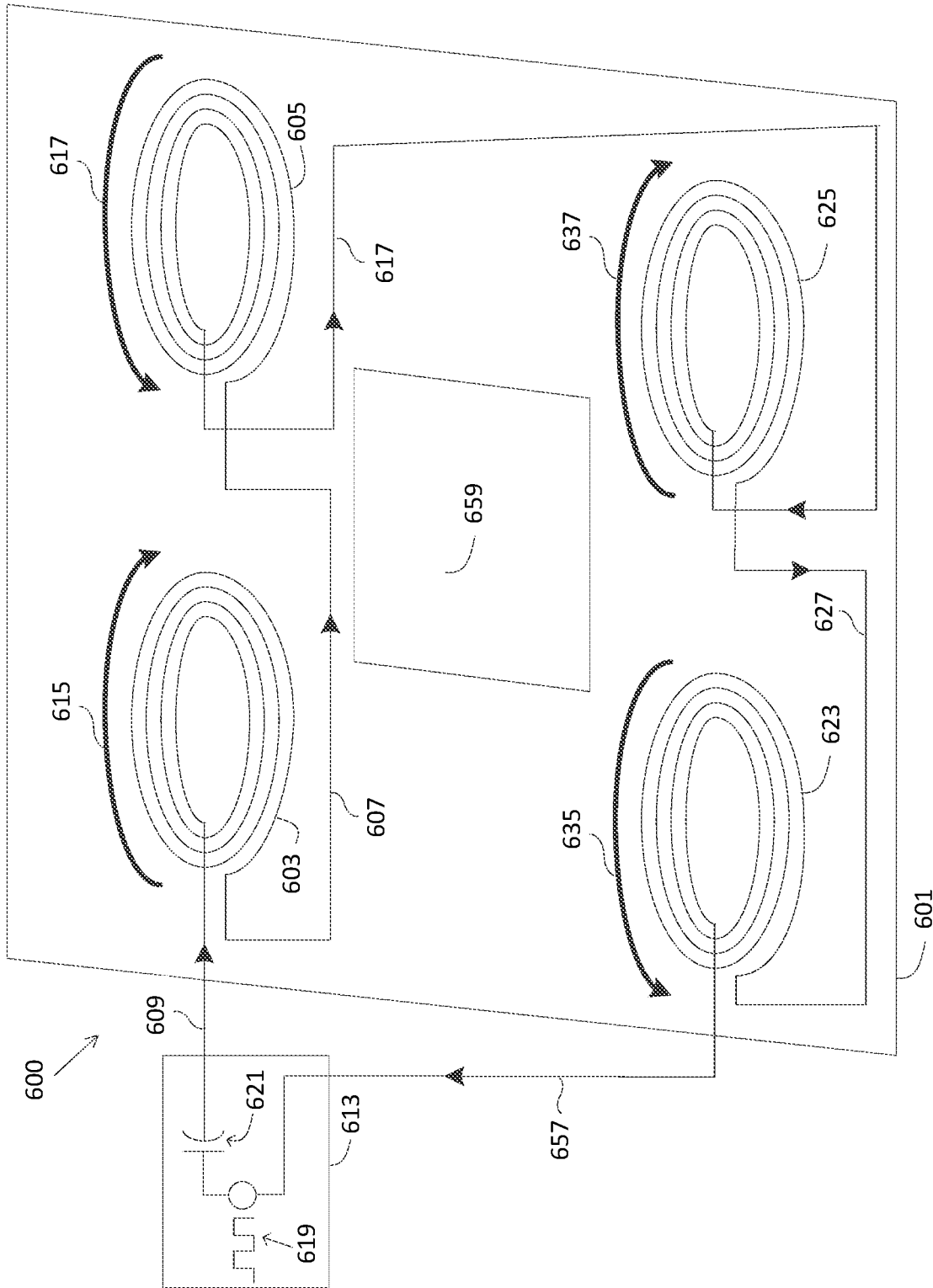

FIG. 6

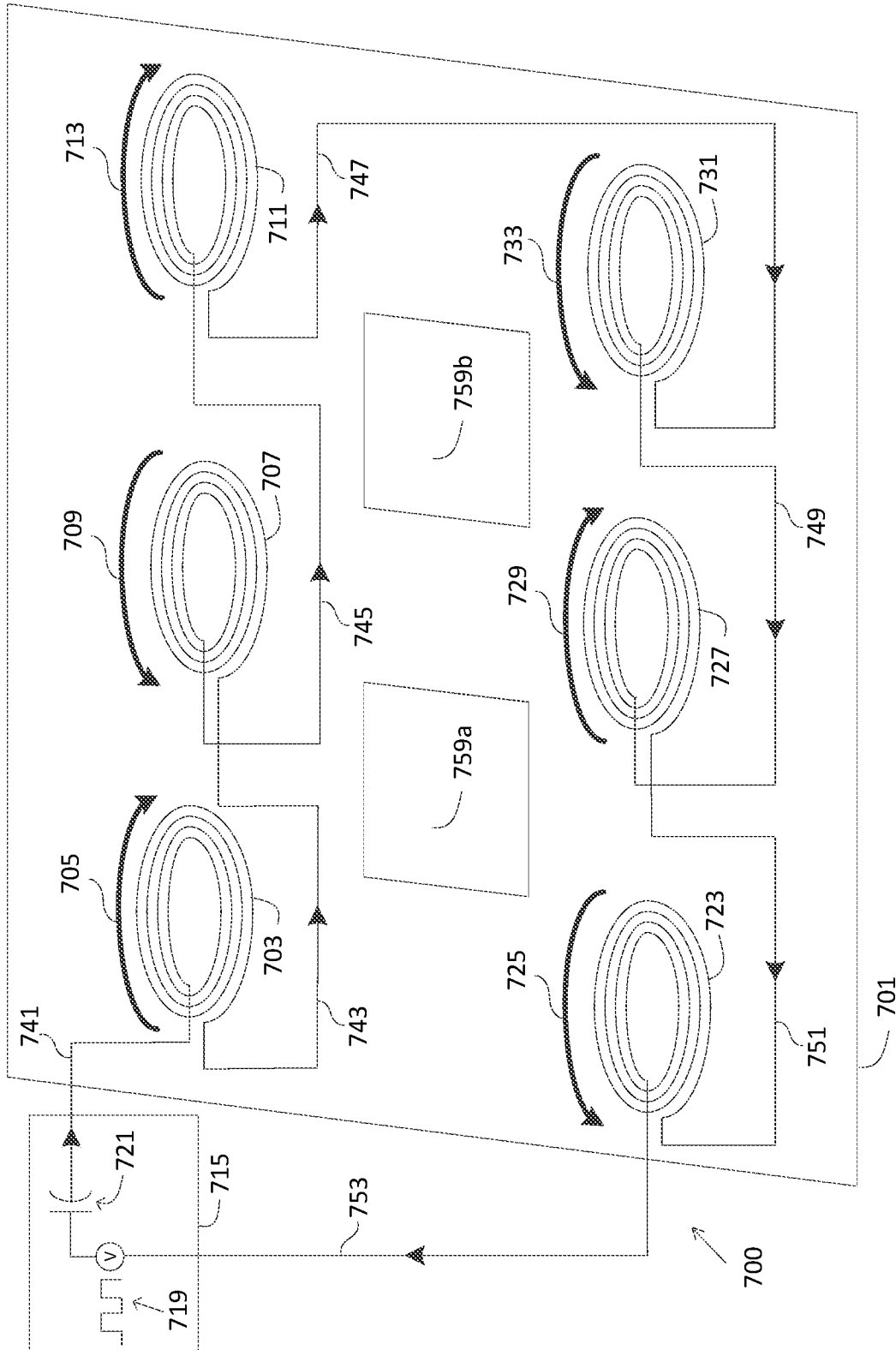

FIG. 7

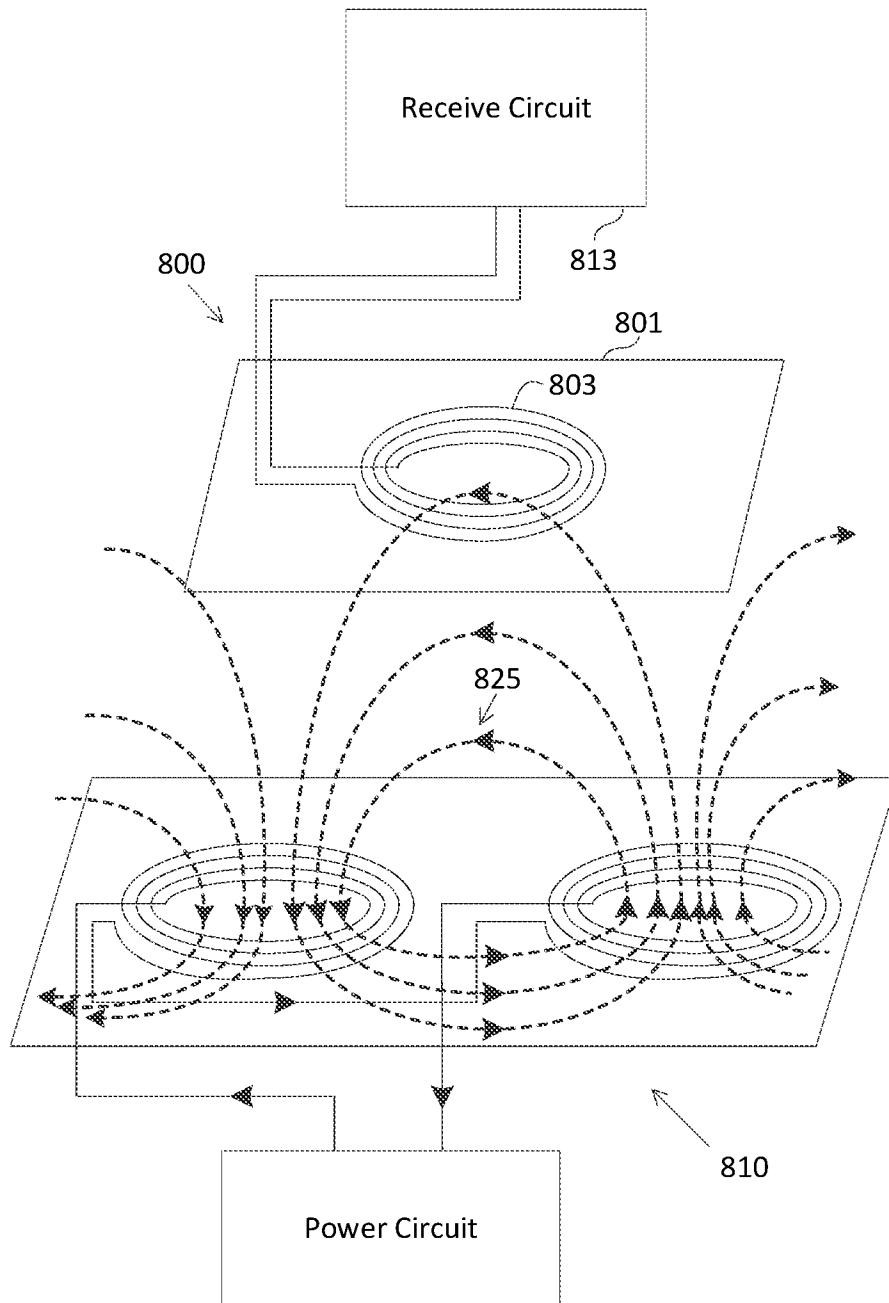

FIG. 8

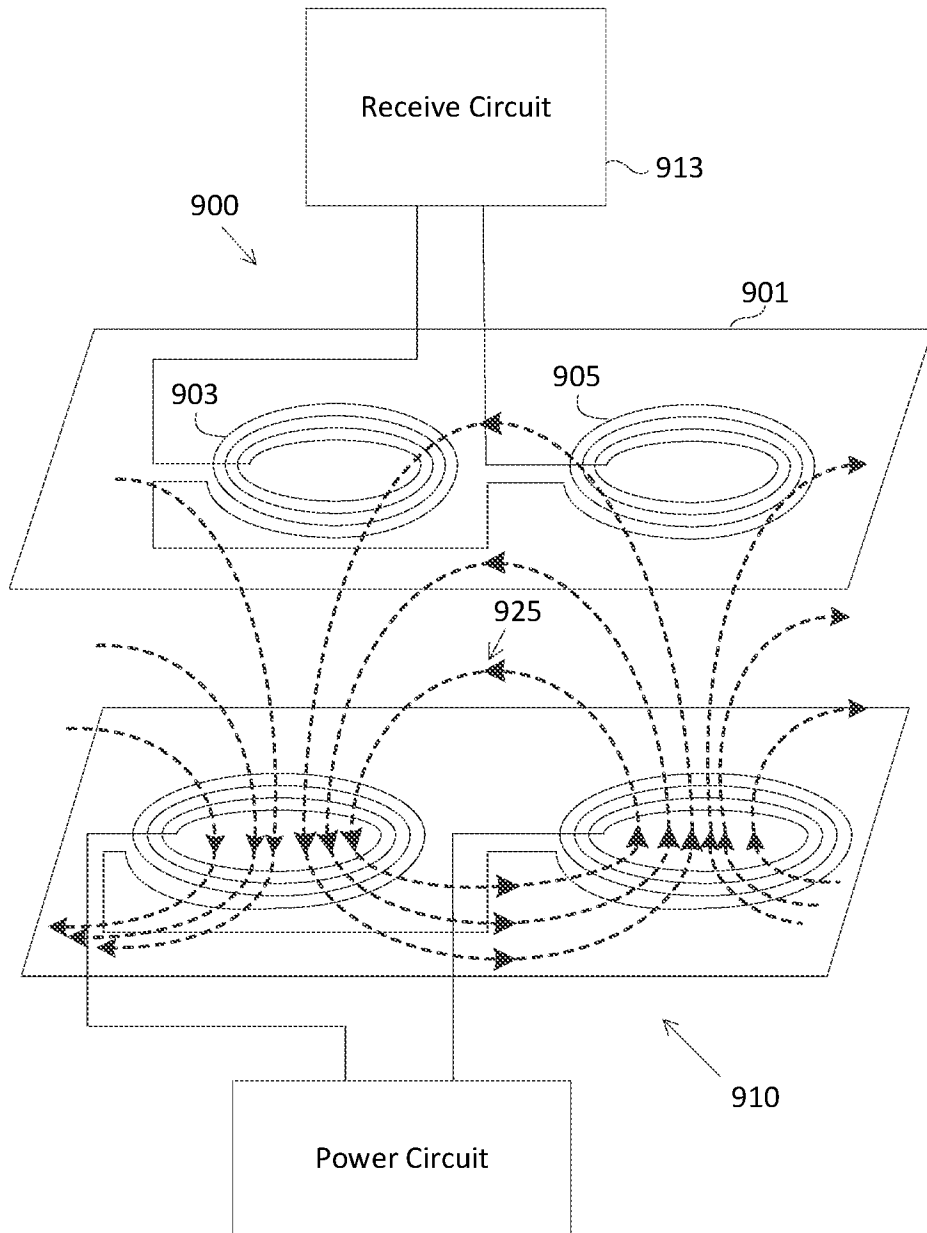

FIG. 9

INTERNATIONAL SEARCH REPORT

International application No.

PCT/US2016/024483

| A. CLASSIFICATION OF SUBJECT MATTER IPC(8) - H01F 38/14; H02J 7/02; H02J 50/00; H02J 50/10 (2016.01) CPC - H01F 38/14; H02J 7/02; H02J 7/025; H02J 17/00; H02J 50/00; H02J 50/10 (2016.02) According to International Patent Classification (IPC) or to both national classification and IPC | | |
|--|--|--|
| B. FIELDS SEARCHED Minimum documentation searched (classification system followed by classification symbols) IPC(8) - H01F 38/14; H02J 7/02; H02J 50/00; H02J 50/10 (2016.01) CPC - H01F 38/14; H02J 7/02; H02J 7/025; H02J 17/00; H02J 50/00; H02J 50/10 (2016.02) | | |
| Documentation searched other than minimum documentation to the extent that such documents are included in the fields searched USPC - 307/104 (keyword delimited) | | |
| Electronic data base consulted during the international search (name of data base and, where practicable, search terms used) Orbit, Google Patents, Google Scholar, ProQuest. Search terms used: wireless, inductive, coil, time, current, direction, magnetic, polarity, air, gap. | | |
| C. DOCUMENTS CONSIDERED TO BE RELEVANT | | |
| Category* | Citation of document, with indication, where appropriate, of the relevant passages | Relevant to claim No. |
| X | US 2013/0093252 A1 (NORCONK et al) 18 April 2013 (18.04.2013) entire document | 1-9, 26-34 |
| --- | | --- |
| Y | | 10-25 |
| Y | US 2014/0232330 A1 (ROBERTSON et al) 21 August 2014 (21.08.2014) entire document | 10-25 |
| A | WO 2013/122483 A1 (AUCKLAND UNISERVICES LIMITED et al) 22 August 2013 (22.08.2013) entire document | 1-34 |
| A | US 2010/0259217 A1 (BAARMAN et al) 14 October 2010 (14.10.2010) entire document | 1-34 |
| A | US 6,212,430 B1 (KUNG) 03 April 2001 (03.04.2001) entire document | 1-34 |
| A | US 2009/0096413 A1 (PARTOVI et al) 16 April 2009 (16.04.2009) entire document | 1-34 |
| A | US 2014/0070622 A (QUALCOMM INCORPORATED) 13 March 2014 (13.03.2014) entire document | 1-34 |
| <input type="checkbox"/> Further documents are listed in the continuation of Box C. <input type="checkbox"/> See patent family annex. | | |
| * Special categories of cited documents: "A" document defining the general state of the art which is not considered to be of particular relevance "E" earlier application or patent but published on or after the international filing date "L" document which may throw doubts on priority claim(s) or which is cited to establish the publication date of another citation or other special reason (as specified) "O" document referring to an oral disclosure, use, exhibition or other means "P" document published prior to the international filing date but later than the priority date claimed "T" later document published after the international filing date or priority date and not in conflict with the application but cited to understand the principle or theory underlying the invention "X" document of particular relevance; the claimed invention cannot be considered novel or cannot be considered to involve an inventive step when the document is taken alone "Y" document of particular relevance; the claimed invention cannot be considered to involve an inventive step when the document is combined with one or more other such documents, such combination being obvious to a person skilled in the art "&" document member of the same patent family | | |
| Date of the actual completion of the international search 25 May 2016 | | Date of mailing of the international search report 20 JUN 2016 |
| Name and mailing address of the ISA/ Mail Stop PCT, Attn: ISA/US, Commissioner for Patents P.O. Box 1450, Alexandria, VA 22313-1450 Facsimile No. 571-273-8300 | | Authorized officer Blaine R. Copenheaver PCT Helpdesk: 571-272-4300 PCT OSP: 571-272-7774 |