

Nov. 27, 1951

P. G. STIMSON ET AL

2,576,152

SHEET DELIVERY AND ASSEMBLY APPARATUS

Filed July 22, 1946

2 SHEETS—SHEET 1

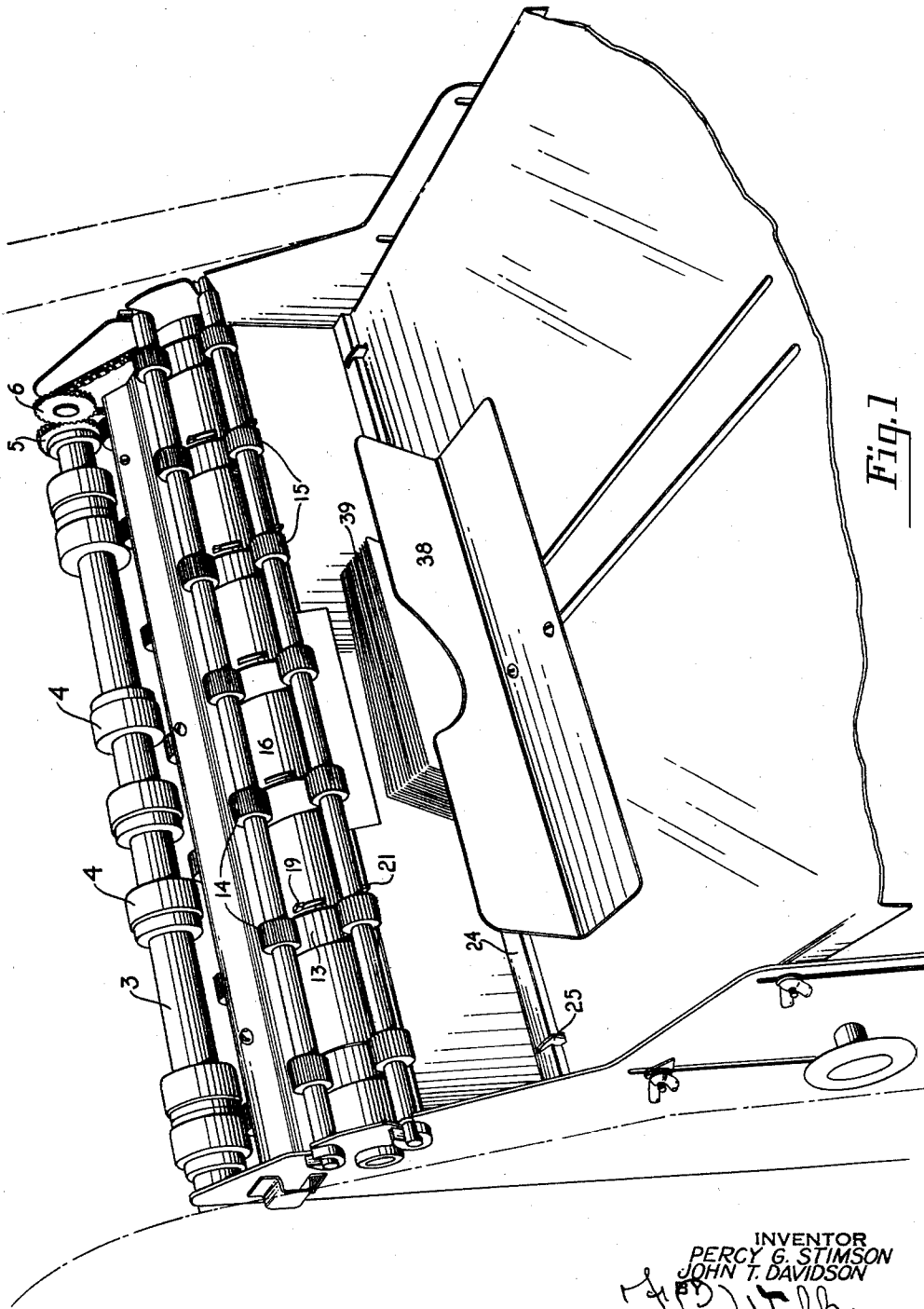

Fig. 1

INVENTOR  
PERCY G. STIMSON  
JOHN T. DAVIDSON  
*J. D. Walker*  
ATTORNEY



# UNITED STATES PATENT OFFICE

2,576,152

## SHEET DELIVERY AND ASSEMBLY APPARATUS

Percy G. Stimson and John T. Davidson, Dayton, Ohio, assignors to The Standard Register Company, Dayton, Ohio, a corporation of Ohio

Application July 22, 1946, Serial No. 685,457

15 Claims. (Cl. 271-87)

1

This invention pertains to sheet feeding and delivery apparatus, and more particularly to means for progressively depositing in vertical positions a rapid succession of individual cards or sheets and automatically assembling them, side by side, into compact formation.

While the invention is particularly useful in assembling multiple printed sheets or cards as they leave a writing or imprinting apparatus or web severing or bursting machine, it is not necessarily limited thereto but may be utilized for assembly of metallic or plastic sheets or manufactured articles as they come from a stamping press, blanking machine or other forming apparatus.

For illustrative purposes, but with no intent to unduly limit or restrict the application or scope of the invention it is herein especially described as for use in conjunction with strip feeding and imprinting apparatus, such as disclosed in patents to Sherman No. 2,172,414 and No. 2,177,675 and with web severing and bursting machines of the type illustrated in patents to Metzner, No. 2,252,720, Sherman et al. No. 2,252,733 and Zent No. 2,355,690, but obviously is not limited thereto.

The object of the invention is to improve the structure as well as the means and mode of operation of sheet delivery and assembly apparatus, whereby it may not only be economically manufactured but will be more efficient in use, automatic in operation, uniform in action, having relatively few operating parts, and be unlikely to get out of repair.

A further object of the invention is to provide an apparatus which is adjustable for operation upon cards or sheets of different sizes and for depositing a rapid succession of cards in upright positions and for assembling the vertical cards into a compact packet.

A further object of the invention is to provide an apparatus of the character mentioned possessing the advantageous structural features, the inherent meritorious characteristics, and the mode of operation, herein described, or their equivalents.

With the above primary and other incidental objects in view as will more fully appear in the specification, the invention intended to be protected by Letters Patent consists of the features of construction, the parts and combinations thereof, and the mode of operation, or their equivalents, as hereinafter described or illustrated in the accompanying drawings.

In the accompanying drawings, wherein is illustrated the preferred, but obviously not nec-

2

essarily the only form of embodiment of the invention,

Fig. 1 is a perspective view of an assembled card or sheet delivery and assembling apparatus embodying the present invention.

Fig. 2 is a vertical sectional view partly broken away, illustrating the operative mechanism.

Figs. 3 and 4 are detail views of the tripping and sheet pushing devices in their normal and operated positions respectively.

Fig. 5 is a further detail view of means for automatically displacing the lower marginal portion of a vertically positioned sheet.

Fig. 6 is a detail view of one of the feeding rollers, in relation to the trip and card pushing arms.

Like parts are indicated by similar characters of reference throughout the several views.

The present sheet feeding and delivery unit is employed in sequence with a writing, imprinting, severing or bursting machine, stamping or forming press or other production unit by which a series of separate sheets or cards 1-1 are supplied to the instant unit in rapid succession, and from which the present unit derives its motive power. The succession of individual sheets or cards 1-1 comprising the output of the preceding unit enter the apparatus over a guide table 2, and between a pair of feed rollers hereafter identified.

At the top of the unit is a drive shaft 3, which may be a driven shaft of the preceding supply unit of which it may constitute a delivery shaft, which progressively ejects the sheets or cards 1-1, for which purpose the shaft 3 is shown provided with a series of knurled collars 4-4.

The drive shaft 3 carries at its extremity a gear wheel 5 which meshes with a gear pinion 6 journaled on a stud 7 projecting inwardly from the side 8 of the main frame of the unit. Connected with the pinion 6 for unison rotation on the stud 7 is a sprocket wheel 9 by which an endless chain belt 10 is driven. The incoming sheets or cards 1-1 pass between a pair of feed rollers 11 and 12. The former carries a sprocket wheel driven by the chain belt 10. The latter comprises a series of knurled collars peripherally engaging with the larger roller 11 to frictionally advance the sheets or cards 1 received from the preceding machine. The sheets or cards 1-1 are advanced by the rollers 11 and 12 over the guide table 2 to a succeeding group of feed rollers 13, 14 and 15. The roller 13 preferably comprises a series of axially arranged relatively spaced sections, having narrow spaces therebetween. It is actuated by the same drive chain 10 in unison with

the roller 11. The rollers 14 and 15 each include series of knurled collars having cooperative relation with the larger roller 13 at peripherally spaced points. Overhanging the roller 13 in peripherally spaced relation is a guide or deflector plate 16, supported at 17, through apertures in which the knurled collars of the rollers 14 and 15 project into frictional engagement with successive sheets or cards 1—1 passing about the roller 13. The arrangement is such that the advancing sheets or cards passing beyond the guide table 2 are engaged between the rollers 13 and 14, and are deflected downwardly about the periphery of the roller 13 by the deflector plate 16. The dependent portions of the sheets or cards are then engaged by the succeeding roller 15 which continues their advancement vertically as shown in Fig. 4.

Pivotally mounted at 18 back of the roller 13 and extending thence within the narrow spaces between succeeding axially aligned sections thereof, is a series of trip levers 19. The free ends of the trip levers 19 project slightly beyond and above the periphery of the roller 13 into the path of the advancing sheets or cards 1—1. The trip levers 19 are interconnected by links 20 with corresponding oscillatory pusher arms 21 pivoted at 22 eccentrically attached to each of which is a retractile spring 23 which tends to urge the pusher arm forwardly into engagement with the advanced card, and simultaneously elevates the trip arm 19. The advancing card passing about the periphery of the roller 13 beneath the deflector plate 16 engages and depresses the ends of the trip levers 19, as shown in Fig. 4. The depression of the trip levers 19, by thrust motion of the links 20 retracts the pusher arms 21 out of the path of the descending card or sheet 1. The knurled roller 15 continues to feed the sheet or card through its changed course. The sheet or card 1 is discharged in a substantially vertical position by the rollers 13 and 15 onto a stop ledge 24. As the card is discharged, its rear margin having passed beyond the depressed end of the trip lever 19, the latter is released and is retracted by the spring 23 acting through the push arm 21 and link 20. By the same action the push arm 21 exerts a thrust pressure upon the top marginal area of the released card or sheet, as shown in Fig. 3, to push the top margin of the card or sheet into engagement with the knurled periphery of the roller 15. The latter then, additional to its previous feeding function in the plane of the sheet, tilts the sheet or card bodily, broad side foremost, as shown in Fig. 3. At about the same moment, an oscillatory "kicker" sector 25 engages the bottom marginal area of the upright card or sheet and pushes it off the ledge 24 onto a table 26, of which the ledge 24 comprises a part. Immediately beneath the feed roller 13 is a sprocket wheel 27 having driven engagement with the primary chain belt 10, and having attached thereto a sprocket wheel 27a for unison rotation, having driving engagement with a second endless chain belt 28. The chain belt 28 passes over an idler sprocket 29 and an intermediate guide and belt tightener 30. The reach of chain belt 28 between the sprockets 27a and 29 is substantially vertically aligned, and is medially engaged by a vertically adjustable sprocket wheel 31. The latter is journaled upon a frame extension 32 of the vertically adjustable table 26 of which the ledge 24 is an integral part. The table 26 is mounted between the side frames 8 for vertical sliding adjustment, by means of a rack and gear adjuster 33

controlled by a hand wheel 33a. The outside of the side frame 8 is graduated at 34 with which a pointer 35, connected to the table 26, coacts to enable accurate adjustment of the table 26 to agree with the vertical dimensions of the sheets or cards.

As the table is elevated and lowered the sprocket wheel 31 travels to and fro relative to the drive chain belt 28, and is uniformly driven by the travel of the chain belt in any position of adjustment. The sprocket wheel 31 is connected by a pitman 36 with a crank 37 connected to the oscillatory "kicker" sectors 25 and 26. The latter are movable to and fro in spaced slots in the ledge 24 of the table by rotation of the sprocket wheel 31 and oscillation of the crank 37, to push the lower portion of the sheet or card, broad side foremost, off the ledge 24 and out of the path of the succeeding sheet or card. The table 26 is provided with an adjustable inclined follower 38 against which the succession of sheets or cards 1—1 are assembled in a pack 39 as shown in Fig. 1.

From the above description it will be apparent that there is thus provided a device of the character described possessing the particular features of advantage before enumerated as desirable, but which obviously is susceptible of modification in its form, proportions, detail construction and arrangement of parts without departing from the principle involved or sacrificing any of its advantages.

While in order to comply with the statute the invention has been described in language more or less specific as to structural features, it is to be understood that the invention is not limited to the specific features shown, but that the means and construction herein disclosed comprise the preferred form of several modes of putting the invention into effect, and the invention is therefore claimed in any of its forms or modifications within the legitimate and valid scope of the appended claims.

Having thus described our invention, we claim:

1. A sheet delivery and accumulator apparatus wherein a succession of individual sheets are delivered, one by one, from a preceding supply thereof, and by which they are uprightly accumulated in compact formation, including a guide table over which the sheets are successively advanced in a plane common with those of the sheets, sheet feeding means including a guide roller, driving means for said sheet feeding means, a deflector plate in concentric spaced relation with the guide roller between which plate and roller the sheets are advanced into a divergent path of travel, a stop against which the advance marginal edge of each sheet comes to rest with the sheet in upright position, a pusher engageable with the top marginal area of each sheet to laterally displace it from the path of the succeeding sheet, a rotating knurled roller into engagement with which the top marginal edge of the sheet is thrust by the pusher and by which the top margin of the sheet is further displaced, broad side foremost, a vibratory kicker device driven by said driving means in synchronism with said sheet feeding means by which the lower marginal area of the sheet is laterally displaced from the stop, a table upon which the displaced sheets are received in substantially upright positions, and adjusting means for varying the elevation of the table and stop to agree with vertical dimensions of the sheets, and an adjustable follower on the

5

table against which the displaced vertically disposed sheets are accumulated.

2. A sheet delivery and accumulator apparatus into which a succession of individual sheets are separately received from a source of supply thereof, including a guide table over which the sheets are advanced in a plane coincident with the planes of the sheets, sheet feeding means, driving means for said sheet feeding means, a roller having peripheral recesses therein, coincident with a peripheral segment of which the sheets are advanced, relatively spaced friction rollers engaging the advancing sheets at relatively spaced points upon said peripheral segments of the roller, a stop in the path of advancement of the sheets against which the sheets are arrested in an upright position, a displacement member controlled by said depressible trip arm engageable with the upper marginal area of the upright arrested sheet to move such marginal portion of the sheet bodily from the path of advancement of succeeding sheets, and a second displacement member automatically operative by said driving means to displace the lower marginal portion of the arrested upright sheet, bodily from the path of succeeding advancing sheets, broad side foremost, and a vertically adjustable receiver for the displaced sheets in unison with which the second displacement member is adjustable, the displaced sheets being accumulated upon said adjustable receiver in overlapping contacting upright positions.

3. A sheet delivery and accumulator apparatus, into which a succession of individual sheets are separately delivered from a source of supply thereof, including a guide table over which the sheets are advanced, sheet feeding means therefor by which they are horizontally advanced in a plane of travel coincident with those of the sheets, direction changing means by which the path of travel of the sheets is changed to a substantially vertical direction, a manually adjustable receiver for the sheets onto which the sheets are deposited in an upright position, and a pusher actuated by the sheets to bodily displace the sheets from the path of advancement of succeeding sheets, broad side foremost, into an upright overlapping contacting accumulation.

4. A sheet delivery and accumulator apparatus into which a succession of individual sheets are separately received from a source of supply thereof, sheet feeding means for advancing the sheets flatly edge foremost, a vertically adjustable receiver upon which the sheets are singly deposited in upright position, and means carried by the receiver for laterally displacing the sheets thereon in upright position, broad side foremost from the path of advancement of succeeding sheets into an overlapping upright contacting accumulation, the lateral displacing means being movable with the receiver and automatically operative in any position of adjustment thereof.

5. A sheet delivery and assembly apparatus, in which a series of individual sheets are received in rapid succession, including a guide table over which the sheets are progressively advanced, feeding rollers therefor, a deflector plate by which the previous course of the sheets is changed into approximately vertical direction, a stop arresting the sheets in upright position, a

6

trip member positioned in the path of the advancing sheets actuated thereby, sheet displacement means including a pusher connected to said trip member for motion therewith intermittently engageable with the top marginal area of the arrested sheets and effective to move the sheets laterally, broad side foremost out of the path of advancement of succeeding sheets.

6. A sheet delivery and assembly apparatus in which a succession of individual sheets are received from a preceding source of supply and by which they are uprightly accumulated in compact formation, including sheet feeding means depositing the sheets in upright position, a pusher intermittently actuated by the sheets and engageable with the upper marginal area of a deposited sheet, a cooperating pusher intermittently engageable with the lower marginal area of the sheet, and conjointly operative to laterally displace a deposited sheet, broad side foremost, out of the path of a succeeding sheet, and into upright assembly side to side with other displaced sheets in a compact packet.

7. A sheet delivery and accumulator apparatus wherein a succession of sheets are received from a preceding source of supply thereof, including sheet feeding means advancing the sheets coincident with the planes thereof, a stop for arresting the sheets in a predetermined position, displacing means shifting the sheets laterally, broad side foremost, out of the path of travel of succeeding sheets, said displacing means including a sheet actuated pusher, and a receiver in which the displaced sheets are accumulated in overlapping facial contact relation.

8. A sheet delivery and accumulator apparatus wherein a succession of sheets are received from a preceding source of supply thereof, including sheet feeding means advancing the sheets coincident with the planes thereof, a stop for arresting the sheets in a predetermined position, a vertically adjustable receiver, a vibratory pusher for displacing the arrested sheets out of the path of advancement of succeeding sheets onto the receiver, actuating means therefor including a revoluble drive wheel, intermediate operating means connecting the drive wheel with the vibratory pusher, a mount for the drive wheel movable in unison with the receiver, power transmission means for actuating the drive wheel disposed in parallel relation with the path of adjustment of the receiver relative to which the drive wheel is adjustable in unison with adjustment of the receiver while maintaining driven engagement therewith, the construction and arrangement being such that the vibratory pusher is actuated by the interengaged power transmission means and drive wheel in various positions of adjustment of the receiver.

9. A sheet or card delivery apparatus including sheet feeding means, a table including an elevated ledge upon which the sheets or cards are deposited in upright position, a rotating knurled roller contiguous to the top margin of the deposited sheet or card, a pusher urging the upper margin of the sheet or card into engagement with the knurled roller, and a second pusher urging the lower margin of the sheet or card off the ledge, the result being that a deposited upright sheet or card is actuated, broad side foremost, out of the path of succeeding sheets or cards into an upright assembly thereof in pack formation.

10. A sheet delivery apparatus wherein a succession of individual sheets are progressively advanced in the planes of the sheets by primary

sheet feeding means, a receiver therefor on which the sheets are deposited on one marginal edge in upright position, means including a part of the primary sheet feeding means for laterally advancing the deposited sheet broad side foremost, while in upright position and an accumulator in which a succession of sheets are assembled in side by side contacting relation in upright position.

11. A sheet delivery apparatus, sheet feeding devices for advancing a succession of individual sheets in a horizontal plane coincident with the planes of the sheets, means for changing the course of the sheets from a horizontal path of travel to a vertical path of travel, coincident with the planes of the sheets, and means including a part of the sheet feeding devices for advancing the sheets laterally, broad side foremost out of their vertical path of travel into an upright side by side assembly thereof.

12. A sheet delivery apparatus, sheet feeding means for advancing a succession of sheets in a predetermined path substantially coincident with the planes of the sheets, a trip member extending into the path of travel of the sheets and displaced therefrom by the traveling sheets, and released by the passage of the sheets therebeyond, and a pusher connected to and movable with said trip member for bodily displacing the sheets laterally from their path of travel, broad side foremost, in a substantially upright position effected by release of said trip member.

13. A sheet delivery apparatus, including sheet feeding devices for advancing successive separated sheets in an edge to edge relationship, driving means for said devices, a trip member mounted for oscillating motion in the path of movement of said sheets, said member being rocked in one direction by the leading edge of each sheet and released for return motion by passage of the trailing edge of the sheet thereover, a spring to effect return motion of said trip mem-

ber, and a pusher arm connected to said trip member for corresponding motion and having a portion to extend into and be withdrawn from the path of movement of the sheets, said portion being arranged beyond the trip member to deliver a kicking impulse to the broadside of each sheet in response to release of said trip member by the trailing edge of said sheet.

14. A sheet delivery apparatus according to claim 13, characterized in that one of said sheet feeding devices includes a knurled roller against which the trailing edge of a sheet is urged by said pusher arm for broadside tilting of the sheet.

15. A sheet delivery apparatus according to claim 14, further characterized by kicking means beyond said pusher arm continuously operated by said driving means to deliver a kicking impulse to the broadside of a sheet in the region of the leading edge thereof at about the same time the pusher arm and knurled roller act upon the sheet in the region of the trailing edge thereof.

PERCY G. STIMSON.  
JOHN T. DAVIDSON.

#### REFERENCES CITED

The following references are of record in the file of this patent:

#### UNITED STATES PATENTS

Number	Name	Date
1,315,559	Kurowski	Sept. 9, 1919
1,434,014	La Bombard	Oct. 31, 1922
1,685,945	Drake	Oct. 2, 1928
1,924,693	Lyman et al.	Aug. 29, 1933
2,063,486	Carroll	Dec. 8, 1936
2,406,489	Case	Aug. 27, 1946

#### FOREIGN PATENTS

Number	Country	Date
398,900	Great Britain	Sept. 25, 1933