

No. 770,227.

PATENTED SEPT. 13, 1904.

D. DONALD.
WIRE STRETCHER.

APPLICATION FILED APR. 9, 1903.

NO MODEL.

Fig. 5.

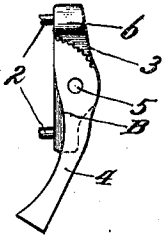

Fig. 1.

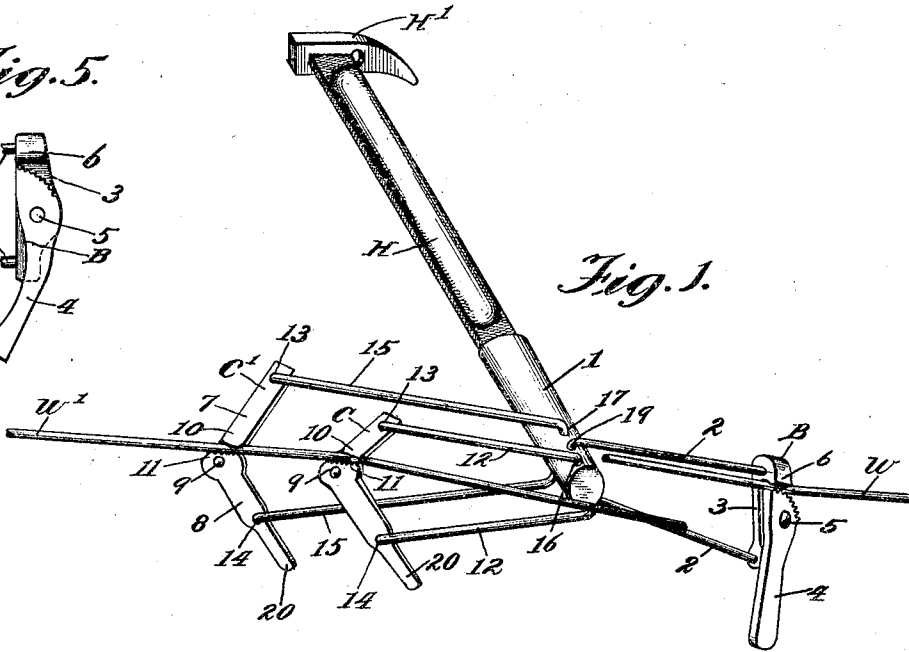

Fig. 2.

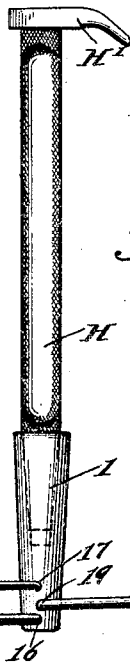

Fig. 4.

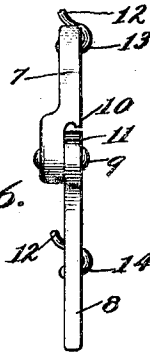

Fig. 3.

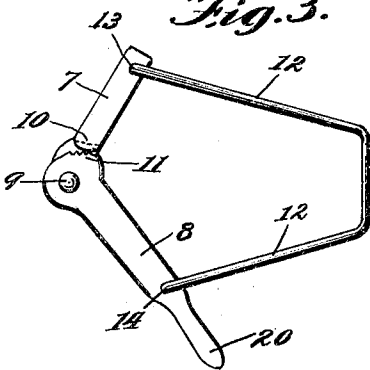
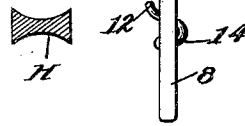

Fig. 6.



Witnesses:

J. B. Weir
J. D. Perry

Inventor:
Donald Donald.

by *[Signature]*

UNITED STATES PATENT OFFICE.

DONALD DONALD, OF MASTERTON, NEW ZEALAND.

WIRE-STRETCHER.

SPECIFICATION forming part of Letters Patent No. 770,227, dated September 13, 1904.

Application filed April 9, 1903. Serial No. 151,709. (No model.)

To all whom it may concern:

Be it known that I, DONALD DONALD, a citizen of New Zealand, and a resident of Masterton, New Zealand, have invented certain new and useful Improvements in Wire-Stretchers, of which the following is a specification.

This invention relates to improvements in wire-stretchers for use in building or repairing plain or barbed wire fences or in putting up telegraph or telephone wires or for any other analogous purpose.

The object of the invention is to provide an improved construction in devices of this character; and it consists in the matters hereinafter set forth, and particularly pointed out in the appended claims.

In the accompanying drawings, Figure 1 is a perspective view of a wire-stretcher embodying my improvements. Fig. 2 is a top plan view thereof. Fig. 3 is a side view of one of the spring-jaws removed from the implement. Fig. 4 is an edge view of the same. Fig. 5 is a detail of the rigid clamp. Fig. 6 is a sectional detail of the file-edged cutting-tool which forms the handle.

The implement thus illustrated consists of a stem 1, provided with a handle H, which may be a permanent extension of the stem, but is preferably a separate detachable part, as hereinafter described.

Pivotally connected to the stem 1 by a double link 2 is a rigid clamp B, consisting of a vertical block 3, secured at its end to the respective ends of the link 2, and a lever-jaw 4, pivotally mounted on a stud 5 of the block 3. The jaw end of the lever 4 is made cam-shaped and opposes a grooved shoulder 6 of the block, so as to form therewith a clamp within which the end W of an inserted wire may be securely fastened by swinging the lever over to force its cam end toward the grooved shoulder. On the other side of the stem and extending in the opposite direction from the rigid jaw above described are a pair of spring-actuated jaws C and C', which are adapted simultaneously to engage the opposite end W' of the wire. Each of these jaws consists of two members 7 and 8, connected by a pivot 9, one member being provided with an overhanging grooved shoulder 10, Fig. 4, and the other

with a cam 5, which opposes the shoulder 11 and is adapted to clamp the end of the wire W against said shoulder. The jaw C is pivotally connected to the stem by a heavy spring-wire loop 12, the middle of which is passed directly through the stem, while its ends are bent over to pivotally engage the jaw members 7 and 8 at points 13 and 14, respectively. In the same manner the jaw C' is pivotally linked to the stem by a spring-wire link 15, which is exactly similar in all respects, except that it is somewhat longer than the spring-link 12. The points 16 and 17, at which the links 12 and 15, respectively, engage and pass through the stem 1, are furthermore located on opposite sides of the point 19, at which the link 2 of the rigid jaws engages the stem, so that if the stem is vibrated on the link 2 as a fulcrum the jaws C and C' will be caused to alternately approach and recede from each other, and the spring tension of the links 12 and 15 of the jaws C and C' is so arranged as to normally press the members of each pair of jaws toward each other and close the jaw upon the wire.

The operation of the implement will now be apparent. When it is desired to tighten a fence or other wire, one of the ends of the wire is tightly clamped within the rigid jaw B, while the other end of the wire is introduced into the jaws C and C'. If now the lever is vibrated back and forth, each of the jaws C and C' will be moved in alternation first away from and then toward the rigid jaw B; but the outward movement of the jaw C will always take place during the inward movement of the jaw C', and vice versa. When either jaw moves out, the pull of its spring-link eases off and the jaw relaxes its hold upon the wire and moves along to a new position on the wire. Then when the jaw is drawn back it takes a fresh grip on the wire in this new position and pulls it in through the other jaw, which in the meantime will have its grip relaxed owing to its outward movement. In this way the continued vibration of the stem serves to draw in the wire hand over hand, as it were, as long as the movement of the stem is continued. The insertion of the wire in the jaws C and C' is

brought about originally by forcing the pivoted central portion of the jaws inwardly toward the stem, and thereby opening them up sufficiently to permit the wire to be inserted laterally within the jaws, and this manipulation is in the present improvement greatly facilitated by extending the ends of the cam members 8 of the jaws down below the points 14, at which they are engaged by the spring-links, so as to form projecting handles 20. By seizing these handles with the fingers and pressing on the middle of the jaw with the thumb it may be easily opened to admit the wire. When the wire is drawn to the desired state of tension, its ends W and W' may be united by any suitable form of knot or fastening, which will usually be made at the fixed jaw B, and to enable a knot to be tied at this point with as little interference from the lever 4 as possible the latter is so shaped that when tightened it forms simply a downward extension of the frame 3, substantially coincident therewith, as shown in detail in Fig. 5, the lever being pivoted to the flat face of the block just beneath the shoulder 6, as illustrated.

For convenience in other manipulations connected with the putting up of fences, and particularly in the severing of the wire whenever desired, the handle H is furthermore herein shown as made in the form of a file-edged cutting-tool the end of which is thrust removably into an appropriate socket formed in the stem 1, as shown in Fig. 2. This cutting-tool is preferably made of the cross-section illustrated in Fig. 6 and fluted or hollowed out on opposite sides, with its sharp edges cut to form a file-like surface. A heavy head H' is also conveniently formed at the end of this handle, so that the latter may be used as a hammer as well as a cutting-tool whenever so desired.

I claim as my invention—

1. A wire-stretcher comprising a lever, a

fulcrum device consisting of a double link 2 pivotally connected to the lever, a vertical rigid bar connecting the free ends of said link and provided with a shoulder at one end and a lever-jaw pivoted to said bar, and a pair of spring-actuated wire-grasping jaws connected to the lever at opposite sides of the point of connection of said double link, for the purposes set forth.

2. A wire-stretcher comprising a stem, a clamp B pivotally connected with the stem by a link 2, jaws C and C' pivotally connected with the stem by spring-links 12 and 15 engaging the stem on opposite sides of its point of connection with the link 2, said jaws C and C' each consisting of a pair of pivotally-connected members each of which is engaged by one end of its spring-link, and one of the members being extended past the point of its connection with the spring-link to form a handle for opening the jaws, substantially as described.

3. A wire-stretcher comprising a stem, a rigid clamp B pivotally connected with the stem by a link 2, jaws C and C' pivotally connected with the stem by spring-links 12 and 15 engaging the stem on opposite sides of its point of connection with the rigid link 2, said rigid clamp consisting of a block provided with a shoulder, and a cam-lever pivoted to the block beneath the shoulder and having a handle extending in the direction of the length of the block when the clamp is closed on the wire, substantially as described.

In testimony that I claim the foregoing as my invention I affix my signature, in presence of two subscribing witnesses, this 7th day of April, A. D. 1903.

DONALD DONALD.

Witnesses:

G. M. MOLTER,
K. A. COSTELLO.