

(19) World Intellectual Property Organization
International Bureau



(43) International Publication Date
30 May 2002 (30.05.2002)

PCT

(10) International Publication Number
WO 02/42707 A1

- (51) International Patent Classification⁷: F28F 13/00, (72) Inventors; and
F25B 9/14 (75) Inventors/Applicants (for US only): TOONEN, Theodor,
Johannes, Peter [NL/NL]; Monseigneur Zwijssenstraat
11, NL-5836 BN Sambeek (NL). LEERKAMP, Peter
[NL/NL]; Braamsluiper 1, NL-5831 PW Boxmeer (NL).
MEUZELAAR, Bob [NL/NL]; Groesbeekseweg 228,
NL-6523 PG Nijmegen (NL).
- (21) International Application Number: PCT/NL01/00853
- (22) International Filing Date:
23 November 2001 (23.11.2001)
- (25) Filing Language: Dutch (74) Agent: VOLMER, J., C.; Exter Polak & Charlois B.V.,
P.O. Box 3241, NL-2280 GE Rijswijk (NL).
- (26) Publication Language: English (81) Designated States (national): AE, AG, AL, AM, AT, AU,
AZ, BA, BB, BG, BR, BY, BZ, CA, CH, CN, CO, CR, CU,
CZ, DE, DK, DM, DZ, EC, EE, ES, FI, GB, GD, GE, GH,
GM, HR, HU, ID, IL, IN, IS, JP, KE, KG, KP, KR, KZ, LC,
LK, LR, LS, LT, LU, LV, MA, MD, MG, MK, MN, MW,
MX, MZ, NO, NZ, OM, PH, PL, PT, RO, RU, SD, SE, SG,
SI, SK, SL, TJ, TM, TR, TT, TZ, UA, UG, US, UZ, VN,
YU, ZA, ZM, ZW.
- (30) Priority Data:
1016713 27 November 2000 (27.11.2000) NL
- (71) Applicant (for all designated States except US): STORK
SCREENS B.V. [NL/NL]; Raamstraat 3, NL-5831 AT
Boxmeer (NL).

[Continued on next page]

(54) Title: HEAT EXCHANGER

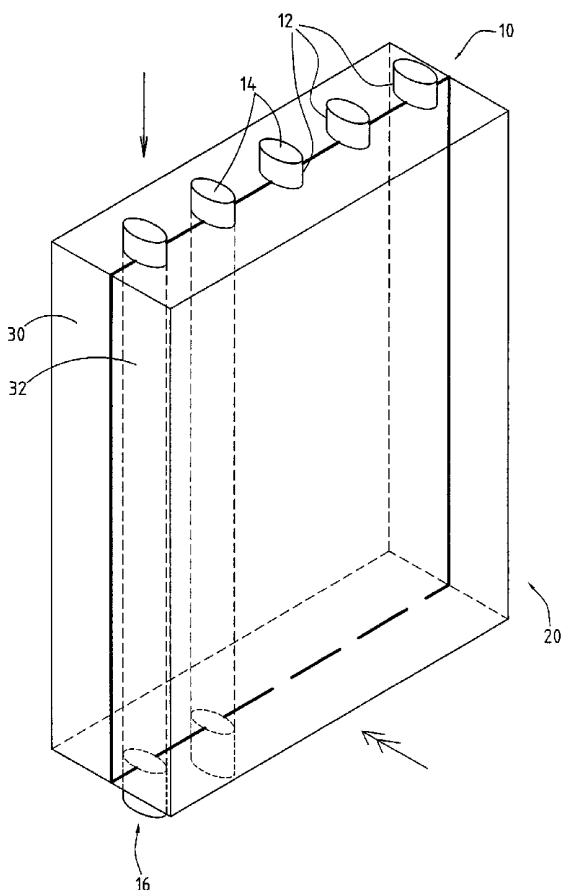

(57) Abstract: In a heat exchanger (10) for transferring heat from a first fluid to a second fluid, which heat exchanger (10) comprises one or more flow passages (12) for a first fluid, the outer wall (26) of these passages is in heat-transferring contact with a flow body (20) made from metal foam for a second fluid. This metal foam has a gradient of the volume density of the metal, so that it is possible to achieve a favourable equilibrium between heat transfer and conduction, on the one hand, and flow resistance, on the other hand.



WO 02/42707 A1



(84) Designated States (regional): ARIPO patent (GH, GM, KE, LS, MW, MZ, SD, SL, SZ, TZ, UG, ZM, ZW), Eurasian patent (AM, AZ, BY, KG, KZ, MD, RU, TJ, TM), European patent (AT, BE, CH, CY, DE, DK, ES, FI, FR, GB, GR, IE, IT, LU, MC, NL, PT, SE, TR), OAPI patent (BF, BJ, CF, CG, CI, CM, GA, GN, GQ, GW, ML, MR, NE, SN, TD, TG).

— *before the expiration of the time limit for amending the claims and to be republished in the event of receipt of amendments*

For two-letter codes and other abbreviations, refer to the "Guidance Notes on Codes and Abbreviations" appearing at the beginning of each regular issue of the PCT Gazette.

Published:

— *with international search report*

Heat exchanger

The invention relates to a heat exchanger for transferring heat from a first fluid to a second fluid, comprising one or more
5 flow passages for a first fluid, which are arranged parallel to and at a distance from one another and the outer wall of which is in heat-transferring contact with a flow body for a second fluid, which is made from metal foam.

10 EP-A-0 744 586 has disclosed a heat-transfer element, for example a plate or tube, with a large heat-transferring surface in the form of copper foam, for use in a heat exchanger, in order to improve the heat transfer. An element of this type is produced by using a vapour deposition process to deposit a
15 powder of copper oxide on a plastic foam which has previously been provided with a suitable adhesive. The foam which has been prepared in this way is then arranged under slight pressure on a plate or tube, which has likewise previously been covered with a copper oxide powder, in order in this way to form a composite
20 element by sintering. After pyrolysis of the plastic foam, the copper oxide is reduced to form copper.

A heat exchanger of the type described above is used, for example, in what are known as thermo-acoustic heat engines. In a
25 heat exchanger of this type, a first heat circuit is formed by a flow of a first fluid, such as a gas or liquid, through generally a plurality of flow passages. A second heat circuit comprises a flow of a second fluid, generally a gas (air, argon), through the porous flow body, which flow body surrounds
30 the flow passages over a certain area. The direction of flow of the second fluid through the flow body is generally virtually perpendicular to the direction of flow of the first fluid in the flow passages. The porous flow body is in heat-exchanging contact with the outer wall of the flow passages. Heat is
35 transferred, for example, from the first fluid to the inner wall of the flow passages and is carried to the outer wall as a result of conduction in the wall material. At the outer wall, heat transfer to the porous flow body takes place through

- 2 -

radiation and conduction. Heat conduction takes place in the porous flow body. When there is only a flow body made from metal foam, this heat conduction is limited, and consequently solid lamellae made from a material with good conductivity are sometimes provided in the metal foam in order to increase the heat conduction. Transfer of heat from the flow body to the second fluid likewise takes place by means of radiation and conduction. The efficiency of the heat transfer overall is dependent, inter alia, on all these transitions, the transfer from the flow body to the second fluid or vice versa - generally the heat transfer on the gas side - in particular possibly representing an inhibiting factor.

It has now been found that, although the use of a metal foam, optionally in combination with lamellae or fins, offers an enlarged heat-exchanging surface area and possibly increased conduction, the flow resistance is relatively high, so that the overall performance, expressed as the ratio between heat transfer and flow resistance, is inferior to that of a conventional heat exchanger with only fins or lamellae. In many cases, an increase in the heat transfer when using a metal foam goes hand-in-hand with a disproportionate increase in the flow resistance.

US-A-4,245,469 has disclosed a heat exchanger in which a porous metal matrix is arranged in a flow passage through which a heat-transferring medium flows. It is stated that this metal matrix has a greater density in an area which is perpendicular to the direction of flow, so that the internal heat transfer coefficient is increased in this area, where the temperature of the environment is much higher than at the end of the passage. To minimize the reduction in volume of the heat-transfer medium which would be produced with a passage of constant diameter, the diameter is increased at the location of the said area. A design of this type aims to improve the internal heat transfer.

Furthermore, DE A1 39 06 446 has disclosed a heat exchanger in which a foam, for example of aluminium, is arranged in a flow

- 3 -

passage. If desired, the pore size in this foam may be varied, i.e. the number of pores may vary.

The general object of the invention is to improve the overall performance, i.e. the abovementioned relationship between heat transfer and flow resistance, of a heat exchanger.

In the heat exchanger of the type described above, according to the invention the metal foam has a gradient of the volume density of the metal. The use of a metal foam with a gradient of the volume density enables the volume density of the foam, in other words the amount of metal, to be adapted to the local heat flux density and flow resistance, while the number of pores (PPI) remains the same. In the metal foam, the heat flux density is highest in the vicinity of the flow passages, so that the metal foam should contain more metal at this location than at the outer periphery of the flow body, where the heat flux density is much lower. This is possible as a result of the volume density of the metal of the metal foam used being varied. The arrangement of the metal foam in the heat exchanger according to the invention has the object of promoting the heat transfer from the metal foam to the wall of the flow passage. A volume gradient of the metal in the metal foam while the PPI remains identical is more effective than varying the number of pores while the thickness of the metal webs which separate the pores remains the same.

Metal foam with a gradient of the volume density of this type can be obtained, for example, by electroplating methods for the electroplating of a plastic foam in an electrolysis bath, as will be explained in more detail below.

It should be noted that FR-A-2 766 967 has disclosed a heat sink, inter alia for electronic components, which comprises a metal foam with a gradient of the thickness of the deposited metal in the thickness direction of the foam.

Since in a production method of this type the density in the foam changes in one direction, the flow body preferably

- 4 -

comprises at least two layers of metal foam, of which layer surfaces which have the same volume density face towards one another. This allows various advantageous embodiments of the flow body to be achieved.

5

In a first preferred embodiment, the volume density of the metal foam increases from an inflow side of the flow body for the second fluid towards a flow passage, so that more metal is present where the heat flux density is greater.

10

The shape of the flow passages is not critical; round tubes, flat hollow plates and the like can be used. However, to limit the flow resistance, the shape of a flow passage is preferably adapted to the flow profile of the second fluid. A flow passage advantageously has an elliptical cross section, the main axis of which extends in the direction of flow of the second fluid. A flow passage of such a shape combines a large heat-exchanging surface area with a relatively low flow resistance.

15

20 The flow body then advantageously comprises two layers of metal foam, preferably having the same number of pores per linear inch (PPI), of which the sides with the highest metal volume density face towards one another. In those sides, recesses for the flow passages are provided.

25

According to another preferred embodiment, which is advantageous in particular on account of the simple modular structure, the flow passages comprise tubular bodies which are rectangular in cross section and are separated by sections of the flow body, the volume density of the sections of the flow body being highest in the vicinity of the outer walls of the flow passages. A module of this preferred embodiment of a heat exchanger may comprise, for example, a flow passage of this type which is rectangular in cross section and of which two opposite walls are provided with a layer of metal foam, of which the layer surface with the highest volume density adjoins the walls in question.

30

35

If a heat exchanger which more closely resembles a heat exchanger with a flow body comprising metal foam parts separated

- 5 -

by lamellae is desired, it is possible to use a plurality of layers of metal foam, of which the gradients of the volume density run parallel to the direction of flow of the first fluid, preferably alternately. In terms of overall performance, this embodiment is less preferred than the other variants described above.

If a metal foam is selected as material for the porous flow body, the heat transfer between metal foam, on the one hand, and the second fluid, on the other hand, is high and no longer the limiting factor, on account of the very large heat-exchanging surface area for a given volume.

The heat conduction in the flow body made from metal foam, however, is low, on account of the porosity thereof, which porosity also has an adverse effect on the heat transfer between the flow body and the outer wall of the flow passages. A gradual increase in the quantity of metal in the foam leads to an improvement in the overall effect of these two contradictory factors.

It is preferable to use a metal foam made from a metal with a high heat conduction coefficient, such as copper. The flow bodies are advantageously also made from a metal with high heat conduction and heat transfer, such as copper. Other suitable metals include, inter alia, indium, silver, nickel and stainless steel. The starting material used for the production of the metal foam is advantageously a plastic foam, such as polyurethane, polyester or polyether with an open network of interconnected pores and a constant PPI value. The diameter of the pores is preferably in the range from 400-1500 micrometers, more preferably 800-1200 micrometers. The volume gradient may rise from less than 5% to more than 95% in the direction of flow of the fluid flowing through the foam. The thickness of the metal deposited on the plastic foam advantageously has a gradient which ranges from 5-10 micrometers, preferably at the inflow side of the flow body, to 30-70 micrometers, preferably in the vicinity of the flow passages, for example 8 micrometers and 42 micrometers, respectively. Metal foams of this type are

- 6 -

easy to produce by means of electroforming of, for example, copper on a substrate of polymer foam in a suitable electrolysis bath, optionally followed by pyrolysis of the polymer. If desired, a thin conductive layer, for example a copper layer, 5 may first be deposited on the foam using other techniques, for example (magnetron) PVD, CVD and the like, after which this film is allowed to grow further in the electrolysis bath.

Various welding techniques (induction, diffusion) and soldering 10 techniques can be used to attach the metal foam to the flow passages. Tin-containing soldering alloys are eminently suitable for copper foam.

The heat exchanger according to the invention is preferably of 15 modular structure, so that a plurality of modules can be combined to form a larger unit.

The invention also relates to a heat pump, for example a thermo- acoustic conversion device, for converting energy as defined in 20 claim 11, in which heat exchangers according to the invention are used. The motor for compressing and displacing the gaseous fluid is, for example, a closed acoustic resonance circuit. The regenerator used preferably has a layered structure comprising foam layers of a metal with poor conductivity. Examples of a 25 thermo-acoustic conversion device of this type include a thermo-acoustic heat engine and a thermo-acoustic motor.

The invention will be explained below with reference to the appended drawing, in which:

30

Figure 1 shows a perspective view of an embodiment of a heat exchanger according to the prior art;

Figure 2 shows a perspective view of a first embodiment of a 35 heat exchanger according to the invention;

Figure 3 shows a perspective view of a second embodiment of a heat exchanger according to the invention;

- 7 -

Figure 4 shows a perspective view of a module of the heat exchanger according to claim 3;

Figure 5 shows a perspective view of a third embodiment of a
5 heat exchanger according to the invention; and

Figure 6 diagrammatically depicts a thermo-acoustic conversion device for energy conversion, in which heat exchangers according to the invention are used.

10

In the embodiment of a heat exchanger 10 according to the prior art which is illustrated in Figure 1, a number of tubular flow passages 12, for example made from copper, are arranged parallel to one another. The direction of flow of a first fluid through
15 the flow passages 12 is indicated by a single arrow, in the situation illustrated from the top downwards. The inlet ends 14 of the flow passages 12 are usually connected to one another with the aid of a distributor cap (not shown). The outlet ends 16 are connected to one another in a similar way. A porous flow
20 body for a second fluid is denoted overall by reference numeral 20 and comprises a number of metal strips 22 which are arranged at a distance from and parallel to one another and each have a layer 24 of metal foam between them. Holes for the flow passages 12 are provided at the appropriate locations in the metal strips
25 22 and layers 24. The metal strips 22 are soldered to the outer walls 26 of the flow passages 12. The flow body 20 is arranged in a chamber or housing (not shown), which are provided with a feed and a discharge and, if desired, distributor means for the second fluid. The sides of the housing of the heat exchanger 10
30 may be provided with coupling means, so that a plurality of heat exchangers can be coupled to one another as required.

Figure 2 shows a preferred embodiment of a heat exchanger according to the invention, in which identical components to
35 those shown in Figure 1 are denoted by the same numbers and references.

The heat exchanger 10 comprises a number of parallel flow passages 12 which are arranged at a distance from one another

- 8 -

and have an elliptical cross section, through which a first fluid, for example a liquid, is guided. The flow body 20 comprises two metal foam parts 30 and 32, each with a gradient of the volume density parallel to the direction of flow of the second fluid, for example a gas. To simplify the figure, the surface with the highest volume density is indicated by a thick solid line in this figure and the following figures. In part 30, the volume density (amount of metal) increases in the direction of flow of the second fluid, while in part 32 the volume density decreases in the direction of flow indicated. Consequently, most metal is present in the immediate vicinity of the flow passages 12, where the highest heat flux density also prevails. The outer surface of the flow body 20, in particular the inflow side (and discharge side), is relatively open.

15

Figure 3 shows another embodiment, in which flow passages 12 which are rectangular in cross section are arranged between sections 40 of the flow body 20. Each section 40 is composed of two metal foam layers 42, whose surfaces with the highest volume density adjoin the outer walls 44 of two flow passages 12 arranged next to one another, while the surfaces having the lowest volume density bear against one another. In this figure, the separating surface between the two foam layers 42 of a section 40 are indicated by a dot-dashed line. Figure 4 shows a module of the embodiment of a heat exchanger according to the invention illustrated in Figure 3.

25

Figure 5 shows yet another variant of a heat exchanger according to the invention, in which six alternately stacked metal foam layers 50 are provided as flow body 20, the gradient of which alternately increases and decreases repeatedly as seen in the direction of flow of the first fluid which is guided through the flow passages 12.

30

Figure 6 shows an outline sketch of a heat pump according to the invention, in this case an embodiment of a thermo-acoustic conversion device 60 for energy conversion, in which heat exchangers according to the invention can advantageously be used.

35

The device 60 comprises a gas-filled acoustic or acousto-mechanical resonance circuit 62 with a regenerator 64, for example made from nickel foam, arranged between two heat exchangers 10 according to the invention. If the device 60 is used as a heat pump, mechanical energy is supplied to the gas, for example via a diaphragm which is made to oscillate with the aid of a linear electric motor. Other possibilities include, for example, a bellows or a free piston structure. The gas which has been made to oscillate and functions as a second fluid extracts heat from a first fluid in the first heat exchanger 10 and pumps the extracted heat via the regenerator to the second heat exchanger 10, where the heat is transferred to a third fluid. In this way, it is possible to transfer heat from a flow of fluid which is at a low temperature to a fluid which is at a high temperature. The periodic pressure variation and gas displacement required for this process takes place in the closed resonance circuit 62 under the influence of a powerful acoustic wave. At this point, it should be noted that the pressure amplitude is many times greater than is customary in a free space, namely of the order of magnitude of 10% of the mean pressure in the system.

If the conversion device is used as a motor, heat is supplied to a heat exchanger at high temperature and is dissipated by a further heat exchanger at low temperature, for example ambient temperature, with the result that the oscillation is maintained. If more heat is supplied than is necessary to maintain the oscillation, it is possible for some of the acoustic energy to be extracted from the resonator as useful output.

The performance of the heat exchangers according to the invention is explained in more detail below on the basis of the following examples.

Various heat exchangers were produced and tested. The porous flow body of a first heat exchanger A is made from strips of copper foam (65 pores per inch) with a length of 90 mm and a width of 12 mm. Holes are stamped out for the flow passages. The

- 10 -

flow passages comprised nine small copper tubes, with an external diameter of 6 mm (internal diameter 4 mm) arranged at regular intervals. The effective passage for the second fluid is 90 mm x 70 mm. Manifolds at the inlet ends and outlet ends of the small copper tubes were connected to a water feed and a water discharge, respectively.

In a second heat exchanger B, a flow body made from the same copper foam is used, but brass lamellae with a thickness of 0.25 mm are fitted in this heat exchanger. The foam and the lamellae are soldered together in a furnace. To prevent the metal foam from closing up under the influence of heat, the strips of copper foam and brass lamellae can also be soldered one by one to the small copper tubes.

15

In a third heat exchanger C, the flow body only comprises 39 brass lamellae.

In a fourth heat exchanger D according to the invention, as shown in Figure 2, having the same dimensions and number of tubes as heat exchangers A-C, the flow body comprises two layers of copper foam, which were produced at room temperature on a PU foam with a pore diameter of 800 micrometers in a copper bath of composition $\text{CuSO}_4 = 250 \text{ g/l}$, $\text{H}_2\text{SO}_4 = 70 \text{ g/l}$, $\text{Cl}^- = 15 \text{ mg/l}$ and $\text{pH} = 0-1$, at a current density of 5 A/dm^2 . After pyrolysis, a copper foam layer produced in this way had a metal thickness of 8 micrometers on one side, while on the other side the thickness of the deposited metal was 42 micrometers. Recesses corresponding to half the diameter of the small copper tubes were provided in the latter sides of these foam layers, after which the small tubes were positioned in these recesses. Tin soldering was used as the joining technique.

These heat exchangers were used to carry out tests, in which a quantity of hot water ($T = \text{approx. } 80^\circ\text{C}$) controlled using a flowmeter was circulated through the small tubes via a thermostat bath. A centrifugal pump was used to suck ambient air through the flow body of the heat exchanger, which was arranged in a passage. The volume of air sucked in was measured using a

- 11 -

flowmeter between the heat exchanger and the centrifugal pump. The pressure drop across the flow body and the inlet temperature T_1 and outlet temperature T_2 of the first flow of fluid, comprising water, and the outlet temperature T_3 of the second
 5 flow of fluid, comprising air, were measured. The quantity of heat Q absorbed by the flow of air is calculated from the volumetric flow rate of water F_W (l/min) and the temperature difference between the incoming and outgoing flow of water (T_1-T_2) using the following formula:

$$10 \quad Q = W_W \cdot (T_1 - T_2) \cdot F_W / 60 \text{ [W]},$$

where W_W is the heat capacity of water (4180 J.Kg.K^{-1}). The tests were carried out at various air velocities. The Reynolds number was determined from the measured gas velocity at the location of the heat exchanger and the hydraulic diameter $D_H=0.0033$ for all
 15 the heat exchangers A-D. The viscosity value applies at the gas temperature of the fresh air sucked in, which temperature was likewise measured. The Nusselt number for the gas side can be calculated by eliminating the heat transfer on the liquid side and assuming turbulent tube flow: $Nu(Re) = Q \cdot D_H / \lambda \cdot \Delta T_1$, where A_W
 20 is the total heat exchange surface area and ΔT_1 is the temperature difference between gas and heat exchanger.

As is customary in the specialist field, the heat transfer is represented as $jH = Nu \cdot Re^{-1} \cdot Pr^{-1/3}$ against Re , where Pr is the
 25 Prandtl number, which for air is 0.7.

The so-called friction coefficient can be calculated in the same way

$$f = A_0 \Delta p / A_W (1/2 \rho v^2)$$

30 from the measured pressure drop and the measured velocity for these heat exchangers of known dimensions and can be represented as a function of the Reynolds number.

The table below shows the results of the heat transfer (jH), the
 35 friction coefficient (f) and the ratio jH/f for $Re=300$ for the various heat exchangers A-D.

Table

Heat exchanger	jH	f	jH/f
A	0.07	20	0.004
B	0.7	40	0.018
C	0.03	1.4	0.021
D	0.5	15	0.033

It can be seen from the above table that, as expected, heat exchanger A (foam alone) provides a higher heat transfer than heat exchanger C (lamellae alone). However, the flow resistance has increased disproportionately. Furthermore, it can be seen that, although heat exchanger B (foam and lamellae) achieves a higher heat transfer than heat exchanger D according to the invention, the flow resistance is very high. The heat exchanger according to the invention has the best overall performance, expressed as jH/f . It is clear from this that, by using a foam with a suitable distribution of metal and by changing the amount of this metal, it is possible to achieve a favourable balance between heat transfer/conduction, on the one hand, and flow resistance, on the other hand.

- 13 -

CLAIMS

1. Heat exchanger (10) for transferring heat from a first fluid to a second fluid, comprising one or more flow passages (12) for a first fluid, which are arranged parallel to and at a distance from one another and the outer wall (26) of which is in heat-transferring contact with a flow body (20) for a second fluid, which is made from metal foam, characterized in that the metal foam has a gradient of the volume density of the metal.
2. Heat exchanger according to claim 1, characterized in that the flow body (20) is composed of two layers of metal foam (30, 32; 42; 50), of which layer surfaces with the same volume density face towards one another.
3. Heat exchanger according to claim 1 or 2, characterized in that the volume density of the metal foam increases from an inflow side of the flow body (20) for the second fluid towards the flow passages.
4. Heat exchanger according to one of the preceding claims, characterized in that the flow passages (12) have an elliptical cross section, the main axis of which extends in the direction of flow of the second fluid.
5. Heat exchanger according to claim 1, characterized in that the flow passages (12) comprise tubular bodies which are rectangular in cross section and are separated by sections (40) of the flow body (20), the volume density of the sections (40) of the flow body (20) being highest in the vicinity of the outer walls (26) of the flow passages (12).
6. Heat exchanger according to claim 2, characterized in that the gradient alternately increases and decreases in the direction of flow of the first fluid.
7. Heat exchanger according to claim 1 or 2, characterized in that the metal of the metal foam is copper.

- 14 -

8. Heat exchanger according to one or more of the preceding claims, characterized in that the connection between the flow body (20) and the outer wall (26) of the at least one flow passage comprises a soldered joint.

5

9. Heat exchanger according to claim 5 or 6, characterized in that the soldered joint comprises tin or a tin alloy.

10. Heat exchanger according to one or more of the preceding claims, characterized in that the heat exchanger (10) has a modular structure and is provided with coupling means for coupling modular heat exchangers to one another.

11. Heat pump for energy conversion, comprising a motor for compressing and displacing a gaseous second fluid, and a heat exchanger for transferring heat from a first fluid to the second fluid, and a heat exchanger for transferring heat from the second fluid to a third fluid, a regenerator (64) being arranged between the heat exchangers, as seen in the direction of flow of the gas, characterized in that the heat exchangers are devices (10) according to one or more of the preceding claims.

12. Heat pump according to claim 11, characterized in that the regenerator (64) comprises a layered structure of a plurality of layers of metal foam made from a metal with pore conductivity.

13. Heat pump according to claim 12, characterized in that the metal of poor conductivity is nickel.

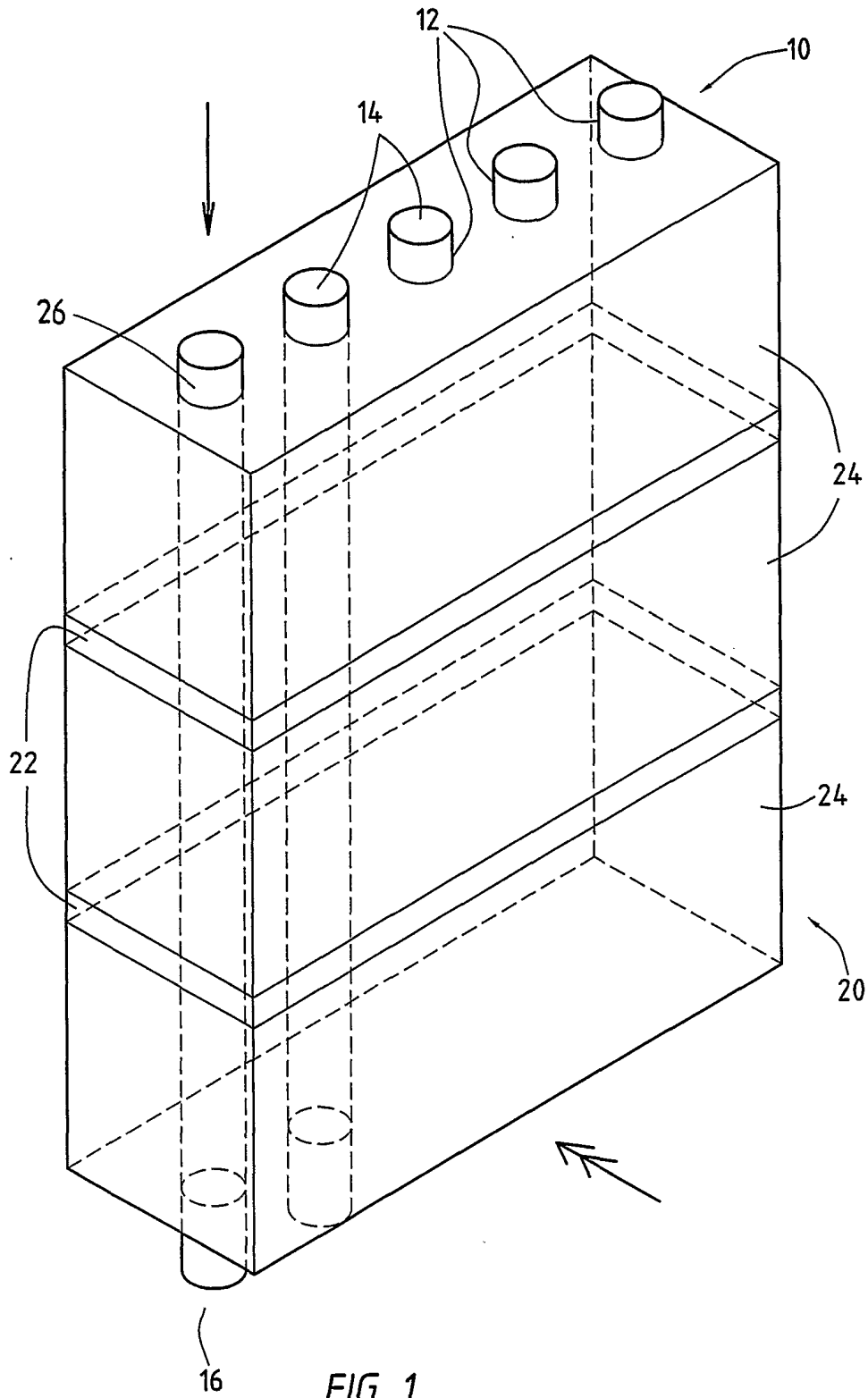
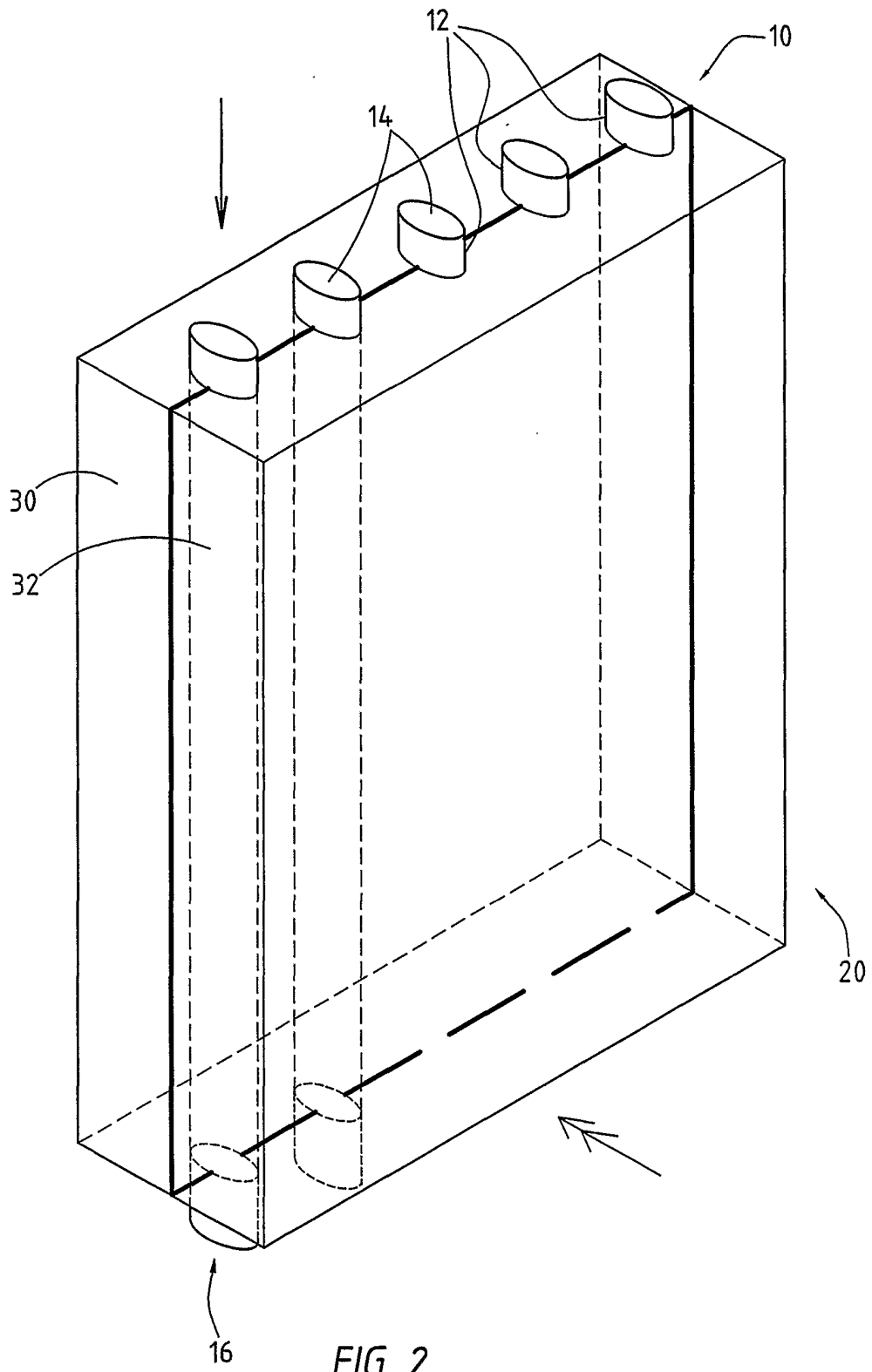

FIG. 1.



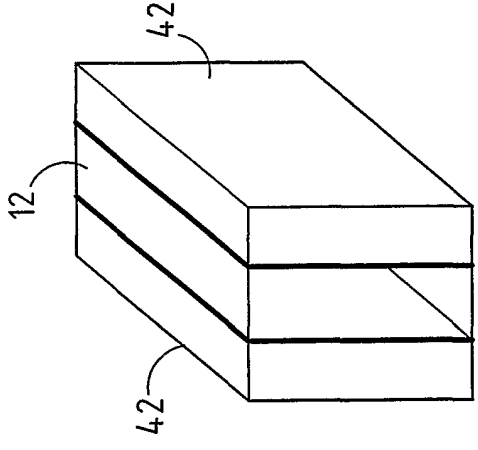

FIG. 4.

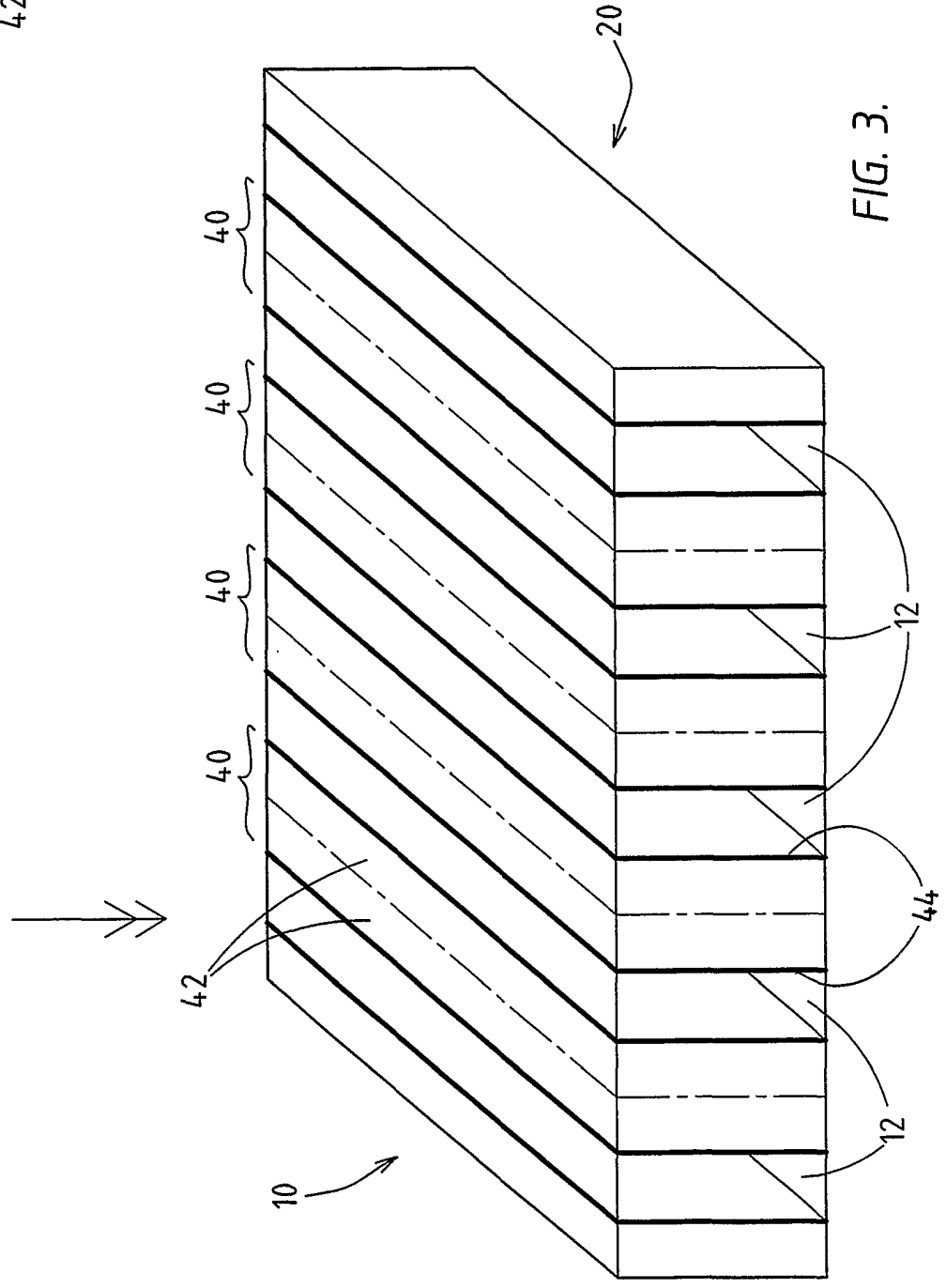

FIG. 3.

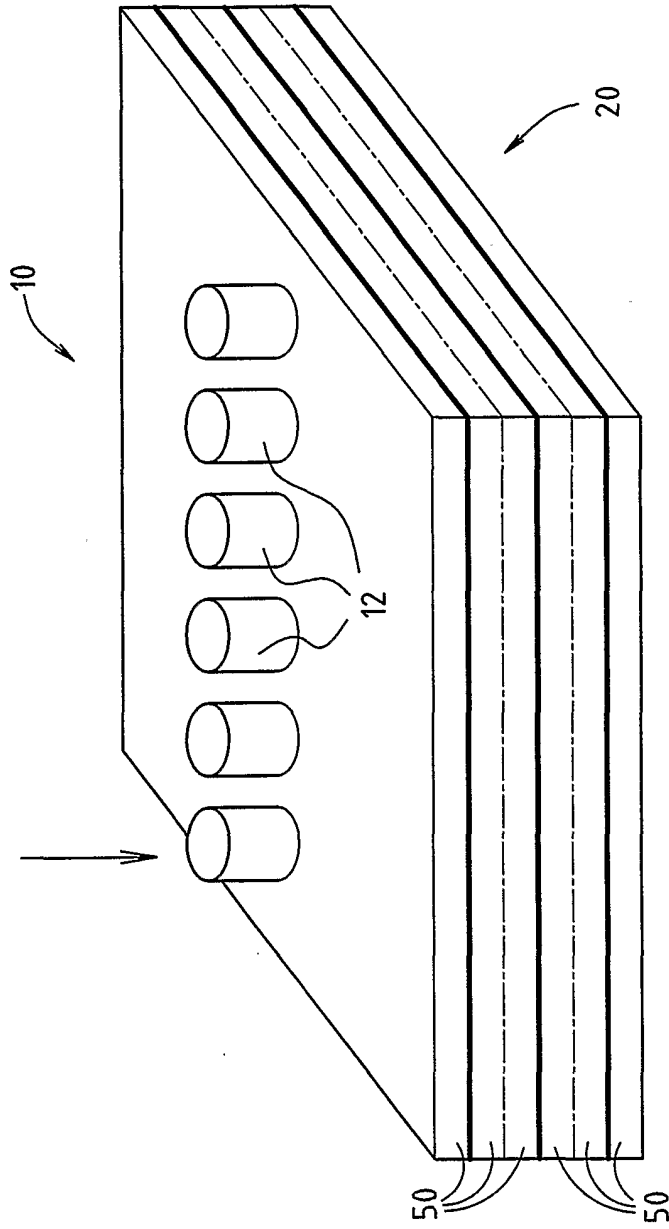

FIG. 5.

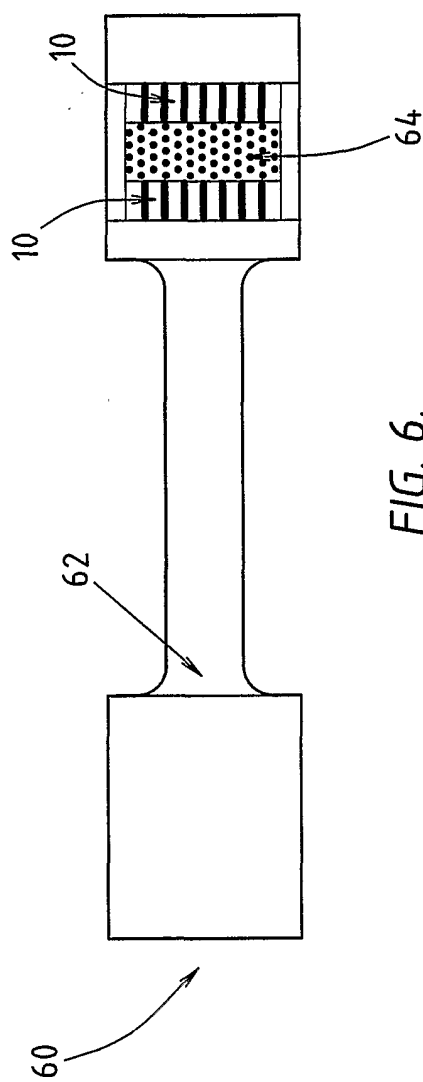

FIG. 6.

INTERNATIONAL SEARCH REPORT

PCT/NL 01/00853

A. CLASSIFICATION OF SUBJECT MATTER
 IPC 7 F28F13/00 F25B9/14

According to International Patent Classification (IPC) or to both national classification and IPC

B. FIELDS SEARCHED

Minimum documentation searched (classification system followed by classification symbols)

IPC 7 F28F F25B

Documentation searched other than minimum documentation to the extent that such documents are included in the fields searched

Electronic data base consulted during the international search (name of data base and, where practical, search terms used)

EPO-Internal, PAJ

C. DOCUMENTS CONSIDERED TO BE RELEVANT

Category °	Citation of document, with indication, where appropriate, of the relevant passages	Relevant to claim No.
X	DE 39 06 446 A (DEUTSCHE FORSCHUNGSANSTALT FÜR LUFT-UND RAUMFAHRT EV) 13 September 1990 (1990-09-13) column 2, line 24 - line 38 column 5, line 9 - line 68; figure 5	1
Y	---	7,8,11
Y	WO 95 23951 A (BROMBERG & CO LTD) 8 September 1995 (1995-09-08) page 5, line 12 - line 25; figure 2	7,8
Y	US 5 901 556 A (HOFLER) 11 May 1999 (1999-05-11) column 8, line 20 - column 10, line 10; figure 1	11

	-/--	



Further documents are listed in the continuation of box C.



Patent family members are listed in annex.

° Special categories of cited documents :

- *A* document defining the general state of the art which is not considered to be of particular relevance
- *E* earlier document but published on or after the international filing date
- *L* document which may throw doubts on priority claim(s) or which is cited to establish the publication date of another citation or other special reason (as specified)
- *O* document referring to an oral disclosure, use, exhibition or other means
- *P* document published prior to the international filing date but later than the priority date claimed

T later document published after the international filing date or priority date and not in conflict with the application but cited to understand the principle or theory underlying the invention

X document of particular relevance; the claimed invention cannot be considered novel or cannot be considered to involve an inventive step when the document is taken alone

Y document of particular relevance; the claimed invention cannot be considered to involve an inventive step when the document is combined with one or more other such documents, such combination being obvious to a person skilled in the art.

* & * document member of the same patent family

Date of the actual completion of the international search

20 March 2002

Date of mailing of the international search report

27/03/2002

Name and mailing address of the ISA

European Patent Office, P.B. 5818 Patentlaan 2
 NL - 2280 HV Rijswijk
 Tel. (+31-70) 340-2040, Tx. 31 651 epo nl,
 Fax: (+31-70) 340-3016

Authorized officer

Beltzung, F

INTERNATIONAL SEARCH REPORT

PCT/NL 01/00853

C.(Continuation) DOCUMENTS CONSIDERED TO BE RELEVANT		
Category *	Citation of document, with indication, where appropriate, of the relevant passages	Relevant to claim No.
A	US 4 245 469 A (FORTINI ET AL) 20 January 1981 (1981-01-20) column 2, line 38 -column 3, line 14; figures 1-5 ----	1-10
Y	FR 2 429 988 A (COMMISSARIAT À L'ÉNERGIE ATOMIQUE) 25 January 1980 (1980-01-25) page 3, line 2 - line 28; figures 1-3 ----	1,2,7
Y	FR 2 766 967 A (SCPS S.A.) 5 February 1999 (1999-02-05) page 7, line 38 -page 8, line 10 ----	1,2,7
A	EP 0 460 392 A (FRAUNHOFER-GESELLSCHAFT ZUR FÖRDERUNG DER ANGEWANDTEN FORSCHUNG E.V.) 11 December 1991 (1991-12-11) column 4, line 41 -column 5, line 28 column 6, line 49 -column 7, line 32 column 8, line 55 - line 57 ----	1-13
Y	PATENT ABSTRACTS OF JAPAN vol. 009, no. 114 (M-380), 18 May 1985 (1985-05-18) -& JP 60 000294 A (MATSUSHITA SEIKO KK), 5 January 1985 (1985-01-05) abstract ----	1
Y	PATENT ABSTRACTS OF JAPAN vol. 009, no. 330 (M-442), 25 December 1985 (1985-12-25) -& JP 60 162195 A (TSUCHIYA SEISAKUSHO:KK), 23 August 1985 (1985-08-23) abstract ----	1
A	----	8
A	DE 298 14 078 U (BAXMANN) 5 November 1998 (1998-11-05) page 9, line 11 -page 10, line 12; figures 1,4,5 ----	1-10
A	US 5 437 328 A (SIMONS) 1 August 1995 (1995-08-01) column 2, line 37 -column 4, line 33; figures 1-4 ----	1-10
A	DE 44 01 246 A (BOSCH GMBH) 20 July 1995 (1995-07-20) column 4, line 20 -column 5, line 19; figure 2 ----	1,11
A	US 5 673 561 A (MOSS) 7 October 1997 (1997-10-07) -----	

INTERNATIONAL SEARCH REPORT

PCT/NL 01/00853

Patent document cited in search report		Publication date	Patent family member(s)	Publication date
DE 3906446	A	13-09-1990	DE 3906446 A1	13-09-1990
WO 9523951	A	08-09-1995	IL 108860 A AU 1996195 A EP 0746739 A1 WO 9523951 A1 US 5727622 A	30-10-1998 18-09-1995 11-12-1996 08-09-1995 17-03-1998
US 5901556	A	11-05-1999	US 5996345 A	07-12-1999
US 4245469	A	20-01-1981	NONE	
FR 2429988	A	25-01-1980	FR 2429988 A1	25-01-1980
FR 2766967	A	05-02-1999	FR 2766967 A1	05-02-1999
EP 460392	A	11-12-1991	DE 4018360 C1 DE 4101630 A1 AT 142135 T CA 2044120 A1 DE 59108133 D1 EP 0460392 A1 JP 2898437 B2 JP 4231403 A US 5151246 A DE 4124591 C1	29-05-1991 12-12-1991 15-09-1996 09-12-1991 10-10-1996 11-12-1991 02-06-1999 20-08-1992 29-09-1992 11-02-1993
JP 60000294	A	05-01-1985	NONE	
JP 60162195	A	23-08-1985	NONE	
DE 29814078	U	05-11-1998	DE 29814078 U1 AU 9531198 A WO 9909594 A1	05-11-1998 08-03-1999 25-02-1999
US 5437328	A	01-08-1995	NONE	
DE 4401246	A	20-07-1995	DE 4401246 A1 WO 9519530 A1	20-07-1995 20-07-1995
US 5673561	A	07-10-1997	AU 3664797 A WO 9806984 A1	06-03-1998 19-02-1998