

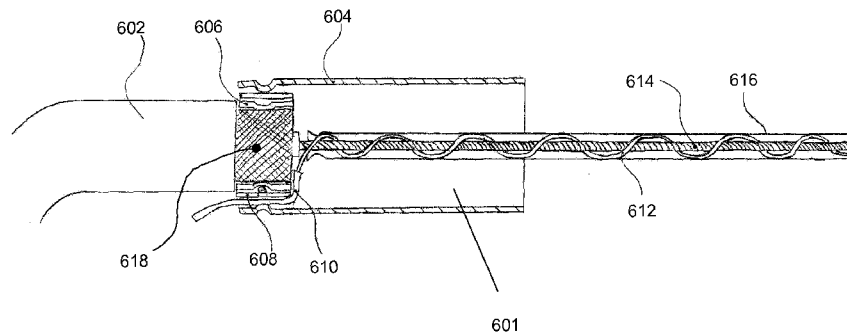

- (51) **International Patent Classification:**  
*G01K 7/04* (2006.01)
- (21) **International Application Number:**  
PCT/US2014/064475
- (22) **International Filing Date:**  
7 November 2014 (07.11.2014)
- (25) **Filing Language:** English
- (26) **Publication Language:** English
- (30) **Priority Data:**  
61/901,052 7 November 2013 (07.11.2013) US
- (71) **Applicant:** **FILTER SENSING TECHNOLOGIES, INC.** [US/US]; 7 Bow Street, Malden, Massachusetts 02148 (US).
- (72) **Inventors:** **SAPPOK, Alexander**; 38 Second Street, Cambridge, Massachusetts 02141 (US). **SMITH, Roland, III**; 11 Doble Avenue, Apt. #1, Medford, Massachusetts 02155 (US). **BROMBERG, Leslie**; 176 Wilshire Drive, Sharon, Massachusetts 02067 (US).
- (74) **Agents:** **NIELDS, LEMACK & FRAME, LLC** et al.; 176 E. Main Street, Suite 5, Westboro, Massachusetts 01581 (US).
- (81) **Designated States** (unless otherwise indicated, for every kind of national protection available): AE, AG, AL, AM, AO, AT, AU, AZ, BA, BB, BG, BH, BN, BR, BW, BY, BZ, CA, CH, CL, CN, CO, CR, CU, CZ, DE, DK, DM, DO, DZ, EC, EE, EG, ES, FI, GB, GD, GE, GH, GM, GT, HN, HR, HU, ID, IL, IN, IR, IS, JP, KE, KG, KN, KP, KR, KZ, LA, LC, LK, LR, LS, LU, LY, MA, MD, ME, MG, MK, MN, MW, MX, MY, MZ, NA, NG, NI, NO, NZ, OM, PA, PE, PG, PH, PL, PT, QA, RO, RS, RU, RW, SA, SC, SD, SE, SG, SK, SL, SM, ST, SV, SY, TH, TJ, TM, TN, TR, TT, TZ, UA, UG, US, UZ, VC, VN, ZA, ZM, ZW.
- (84) **Designated States** (unless otherwise indicated, for every kind of regional protection available): ARIPO (BW, GH, GM, KE, LR, LS, MW, MZ, NA, RW, SD, SL, ST, SZ, TZ, UG, ZM, ZW), Eurasian (AM, AZ, BY, KG, KZ, RU, TJ, TM), European (AL, AT, BE, BG, CH, CY, CZ, DE, DK, EE, ES, FI, FR, GB, GR, HR, HU, IE, IS, IT, LT, LU, LV, MC, MK, MT, NL, NO, PL, PT, RO, RS, SE, SI, SK, SM, TR), OAPI (BF, BJ, CF, CG, CI, CM, GA, GN, GQ, GW, KM, ML, MR, NE, SN, TD, TG).
- Published:**  
— with international search report (Art. 21(3))

(54) **Title:** ADVANCED RADIO FREQUENCY SENSING PROBE



**Figure 6A**

(57) **Abstract:** A radio-frequency probe system with a transmitting or receiving element integrated into a cable assembly is disclosed. In some embodiments a preferred configuration may contain one or more sensing elements integrated into the transmitting or receiving element. In another embodiment, the radio frequency probe comprises an antenna body fixed to a coaxial cable, in which the center conductor of the coaxial cable serves as the transmitting or receiving element. A method for monitoring, transmitting, or detecting one or more parameters using a single radio frequency probe is also disclosed.

## **Advanced Radio Frequency Sensing Probe**

This application claims priority of U.S. Provisional Patent Application Serial No. 61/901,052, filed November 7, 2013, the disclosure of which is incorporated by reference in its entirety.

This invention was made with U.S. Government support under Contract Number DE-EE0005653 awarded by the United States Department of Energy. The Government has certain rights in this invention.

### **Background**

Radio frequency (RF) - and microwave-based sensing techniques, including cavity perturbation methods and the like, are used in many applications ranging from laboratory and research instrumentation to process control systems and even on-vehicle sensors. In many applications, antennas or probes are used to transmit and/or receive radio frequency or microwave signals to conduct these measurements. Oftentimes, additional information is required to accurately interpret the measurement results, as external factors, such as temperature or moisture for example, may introduce additional variables that influence the measurements.

There is a further need in many applications for robust sensing systems, capable of withstanding high levels of vibrations, large temperature variations, harsh or corrosive environments, exposure to the elements, and similar demanding requirements. Many of these requirements can only be met through complex, cumbersome, and expensive systems, which suffer from the following limitations.

First, current sensing systems employing antennas or probes to transmit and receive radio frequency or microwave signals require additional sensors to measure multiple parameters. Temperature sensors, moisture sensors, pressure sensors, and the like are often required (in addition to the antenna or probe) to conduct these ancillary measurements, adding additional cost and complexity to the system.

Second, many conventional antennas and RF/microwave probes are not robust and are incapable of surviving extended operation with exposure to high temperatures, high vibration levels, thermal shock, corrosive or dirty environments, oxidizing or reducing conditions, and the like. Environmental exposure, rain, snow, and salt water for example, as well as exposure to chemicals and solvents, such as oils, fuels, acids, and similar chemicals, is also detrimental to many conventional RF/microwave probes and antennas.

Third, RF/microwave probes and antennas designed for operation in harsh environments are generally expensive, large and bulky, and ill-suited for use in low-cost measurement systems. The expense in these systems stems from both the requirement to utilize more exotic and higher priced materials, as well as the added cost and complexity involved in the manufacture and assembly of the antenna or probe and associated connectors.

Fourth, conventional antenna systems suffer from limitations of variability introduced by reflections, losses, and incorrect impedance matching. Many of these sources of variability are related to the antenna design itself and the manner in which the antenna is connected to the signal cable. For example, most antennas require additional components to connect the antenna to the signal cable, such as interconnects and ancillary components. Not only do these components exhibit some inherent variability,

which may also vary over time (corrosion, loosening, moisture induction, etc.), but they are also subject to operator error, including misalignment, over-tightening, under-tightening, reliability and the like.

Fifth, radio frequency connectors suitable for use in the microwave range are expensive, particularly when high temperature operation is required. Robust connectors, such as Type N for example, are also bulky, making them ill-suited for applications where a small form-factor is required. In some cases, the size of these connectors may be of the same order as the actual component or sensor.

Sixth, the use of an interconnect on the end of an RF probe or antenna, such as a conventional RF connector (BNC, SMA, Type N, and many others) allows for the connection of any type of cable to the antenna with the same type of matching connector, or with a different type of connectors through the use of a suitable adapter. In applications where the measurement, or operation of the system, requires the use of a cable with specific characteristics (impedance, length, temperature rating, or similar performance specifications), additional sources of error may easily be introduced when the connecting cable is replaced with another cable not meeting the required specifications. Thus, measurement systems in which the antennas and RF probes contain an interconnect, may be susceptible to errors introduced by the installation of incorrect cables.

Therefore, it would be beneficial if there were an RF probe or antenna system that addressed the problems described above. Such a system would be advantageous in that inherent variability in the probe or antenna performance would be reduced, and sources of operator error eliminated, ultimately improving the performance of the overall measurement system with which the antennas or probes are used. In addition, probes or antennas containing

multiple sensing elements, or the ability to monitor multiple parameters, an RF signal and temperature, for example, or an RF signal and pressure in another example or an RF signal and gas or liquid composition in yet another example, would greatly simplify the measurement system, by allowing one or more parameters to be monitored with the same probe.

The probes and antennas described herein may be used in a number of applications, ranging from cavities to transmission lines, and even in free space. One range of applications include systems which monitor changes in the dielectric properties of a material or a mixture of materials in order to deduce some information regarding the state of the system. A particular example of such a system is a moisture measurement system used to monitor moisture levels in various materials. Another example includes fluid blend sensors, where the blend may be composed of one or more liquid, gas, or solid materials, and where changes in the dielectric properties of the mixture of materials may provide some information on the state of the system, such as the composition of the mixture, flow rate, or other parameters of interest.

Yet another example includes a class of radio-frequency measurement systems applied to monitor exhaust emissions or the state of various emission control devices. Radio-frequency or microwave systems used to monitor the loading state of particulate filters, such as the amount of soot or ash accumulated in a diesel particulate filter, is one exemplary application. Another application includes the monitoring of various gaseous species, such as oxygen or oxides of nitrogen (among others), adsorbed onto various catalytic emission aftertreatment components, such as three-way catalytic converters, selective catalytic reduction systems, oxidation catalysts, or lean NO<sub>x</sub> traps, to name a few. In yet another embodiment, the monitored parameter may

be a change in the dielectric properties of the material itself, such as the filter material in the case of a diesel particulate filter, in one example and the catalysts substrate, washcoat, or catalyst material in yet another example. Although aftertreatment filters and catalysts are described and are particularly challenging, any filter system or catalyst system can use the technology described herein.

In many applications, there is a need for antennas or measurement probes suitable for extended operation over a range of conditions, including exposure to high temperatures, vibration, mechanical stresses, water and other liquids, and the like. In addition, such antennas or probes may require periodic removal for inspection, maintenance, or replacement. An antenna or probe system which is robust and exhibits little inherent variability is required to ensure proper operation of these systems, and also minimize errors introduced by operators when installing or replacing such antennas or probes.

Furthermore, many measurement systems suffer from variability introduced by changes in parameters other than the measurement parameter of interest. For example, external variables including moisture, flow, temperature, pressure, composition, or the introduction of contaminants, and the like may also affect the performance of radio-frequency or microwave measurement systems. A particular example is the determination of soot accumulation on particulate filters, in which case the dielectric properties of the soot also vary with temperature. Another example is the dielectric state of the catalyst material or the gas-phase species absorbed or adsorbed on a catalyst, or the liquid or solid phase species collected on a filter. Many other measurement systems exhibit similar cross-sensitivities to temperature and other parameters. It is, thus, desirable to monitor the various parameters that may

affect the measurement using a single probe, as opposed to using one or more sensors, where each sensor only measures one specific parameter.

The antenna probe system described herein may be applied to any number of applications in which reducing the variability of the antenna is important to improve the signal. Other applications include those in which the number of additional sensing elements may be reduced through the use of a single antenna probe containing one or more sensing elements.

### **Summary**

This disclosure relates to an advanced radio-frequency probe system with a transmitting or receiving element integrated into a cable assembly. In some embodiments, a configuration may contain one or more sensing elements integrated into the transmitting or receiving element. In another embodiment, the radio frequency probe comprises an antenna body fixed to a coaxial cable, in which the center conductor of the coaxial cable serves as the transmitting or receiving element. A method for monitoring, transmitting, or detecting one or more parameters using a single radio frequency probe is also disclosed. Another embodiment includes electronics for generating the signal inside the antenna assembly, or mounted directly on the antenna assembly eliminating the need for high frequency connectors or cables between the antenna assembly and the RF generator or RF detector.

### Brief Description of the Drawings

**Figure 1** shows a radio frequency measurement system.

**Figure 2A** shows a coaxial cable with an integrated antenna.

**Figure 2B** is cross-sectional view of an antenna integrated with a coaxial cable.

**Figure 2C** is a cross-sectional view of a preliminary step in the assembly of a coaxial cable with integrated antenna and one piece outer sleeve.

**Figure 2D** is a cross-sectional view of a subsequent step in the assembly of a coaxial cable with integrated antenna and one piece outer sleeve.

**Figure 3A** shows an initial step in terminating a conventional coaxial cable with an antenna probe.

**Figure 3B** shows a second step in terminating a conventional coaxial cable with an antenna probe.

**Figure 3C** shows a completed coaxial cable terminated with an antenna probe.

**Figure 4A** is a cross-sectional view of an antenna integrated with a coaxial cable showing additional details of the system, including one type of connection.

**Figure 4B** is a cross-sectional view of an antenna integrated with a coaxial cable showing additional details of the system, including another type of connection.

**Figure 5A** is a radio frequency probe with an integrated second sensing element.

**Figure 5B** is a radio frequency probe with a single sensing element.

**Figure 6A** is a cross-sectional view of an antenna probe integrated with a coaxial cable containing a second sensing element.

**Figure 6B** is a cross-sectional view of an antenna probe integrated with a coaxial cable containing a second sensing element extending from the end of the antenna.

**Figure 6C** is a cross-sectional view of an antenna probe integrated with a coaxial cable containing a second sensing element extending from the end of the antenna.

**Figure 7** is an exploded view of the components used to assemble an antenna probe integrated to the end of a coaxial cable, having a second sensing element.

**Figure 8** is a radio frequency probe containing various sensing elements in various positions.

**Figure 9** is a plot of temperature measurements for two radio frequency probes with integrated temperature sensors

compared with a conventional thermocouple, installed on a diesel burner system.

**Figure 10** are two radio frequency resonance curves for two probes, one with and one without an integrated temperature sensor showing less than 0.35% variation between the two signals.

**Figure 11** shows an antenna integrated with a RF generator or a detector.

**Figure 12A** is an antenna assembly where the antennae and the RF electronics are placed on a board.

**Figure 12B** is an alternative antenna assembly where a hollow tube is used as second element of the antenna.

**Figure 13** is a cross-sectional view of an antenna probe integrated with a coaxial cable containing a second sensing element integrated into the antenna.

### **Detailed Description**

The present disclosure is based on the recognition that conventional coaxial cables can be terminated with an antenna or probe end, without the need for ancillary interconnects and related components. The disclosure addresses the need for robust radio frequency antennas or probes which exhibit low inherent variability, and through their design, reduce operator-induced errors when the probes are installed, removed, or replaced. Probe designs

with enhanced functionality are also disclosed, which permit the measurement of more than one parameter from a single antenna.

Throughout this disclosure, it should be noted, that the terms radio frequency "probe" or "antenna" are used interchangeably and intended to describe the same system, namely a device which is, at a minimum, capable of transmitting or receiving a radio frequency signal. The frequency range is intended to span from KHz to THz, depending on the application, with preferred frequencies in the MHz to GHz range for certain applications. Similarly, the terms "radio frequency" and "microwave" are used interchangeably in this disclosure to describe signals with frequencies from the KHz to THz range.

One application in particular includes radio frequency or microwave systems for monitoring the state of emission control devices. Diesel and gasoline particulate filters represent one category of emission control devices to which radio frequency sensing is applied to monitor soot and ash levels in the filter. Catalytic emission control devices, such as three-way catalytic converters, oxidation catalysts, selective catalytic reduction systems, and lean NO<sub>x</sub> traps, among others, represent another category of emission control devices to which radio frequency sensing may be applied to monitor parameters related to the state or function of the device, such as the amount of various adsorbed gaseous components (oxygen, nitrogen oxides, ammonia, and others).

Other applications include any type of cavity measurement systems, such as cavity perturbation measurement systems. In yet another embodiment, the antenna may be operated in free space, without the need for a cavity. Another embodiment may be the integration of the antenna in a transmission line.

The antennas used in some of these applications must be capable of withstanding high exhaust temperatures, oftentimes in excess of 600 °C, must be sealed to prevent the escape of exhaust gases to the environment, must withstand high vibration levels, exposure to the elements, harsh chemical environments, and a number of additional demanding requirements. Furthermore, the antennas must be easily installed during the factory assembly process, and also be readily serviceable and replaceable in the field with minimal impact on the measurement system performance.

The challenges associated with these demanding requirements are many, particularly when considering component size and cost constraints. In applications such as radio frequency systems used to monitor the state of emission control devices, where the metallic housing of the emission control devices serves as a microwave resonant cavity, the measurement can be very sensitive to the antenna design, location, and orientation of the antenna in the housing. Cables and interconnects between the radio frequency transmitter and receiver and the antennas can introduce losses, reflections, phase shift, and other variables which affect the signal and resulting measurement, in addition to increased costs and reliability issues. The

present disclosure reduces or eliminates these sources of variability in the system.

The presence of interconnects, in particular near transitions to components subject to high levels of vibration, also introduces the possibility of loosening over time, or introducing additional sources of variability into the system. Moisture intrusion, corrosion, the degradation of the connector through high temperatures, and related deleterious effects are a concern. In addition, the use of an interconnect also provides easy access to disable the sensing or measurement system, in some cases.

Furthermore, a number of sensors are generally installed on the afore-mentioned emission control devices, including temperature sensors, pressure sensors, gaseous composition sensors (oxygen sensors, NO<sub>x</sub> sensors, and the like), soot sensors, and related sensors, in addition to the radio frequency antennas. In addition, accurate radio frequency measurements of the state of the emission control device often requires input from one or more sensors, such as temperature measurements, in one example, to compensate or correct the radio frequency signal in cases where cross-sensitivities to other parameters exist. In a particular example, soot level determination in diesel or gasoline particulate filters through radio frequency means requires temperature compensation to correct for the variation in the dielectric properties of the soot with temperature. However, many applications of radio frequency sensing require similar methods to compensate for variations in temperature or other parameters. Aside from temperature, other parameters or conditions may also influence cavity

resonance measurements or antenna measurements and must be known or monitored in order to improve the RF measurements.

The present disclosure also describes a radio frequency probe capable of measuring one or more parameters, in addition to transmitting or receiving a radio frequency signal. In this manner, the same probe may be used to monitor one or more parameters, thereby eliminating the need for other sensors. The parameters monitored by the probe need not be the same parameters for which compensation of the radio frequency signal is required. For example, a probe may be configured to monitor temperature and pressure, in addition to transmitting or receiving a radio frequency signal, even though the radio frequency signal only requires temperature compensation. In this case, the pressure measurement may serve some other purpose, which may or may not be related to the radio frequency measurement. In yet another example, the radio frequency probe may be configured to monitor temperature and a gaseous emissions component.

While examples have been given related to emission control systems and devices, the radio frequency probes described herein are equally applicable to a number of applications ranging from laboratory instruments and medical devices, to process control systems, chemical reactors, sensors, and even wireless signal transmission. The probes may be mounted in a radio frequency cavity, a wave guide, or used in systems transmitting radio frequency signals through free space. Applications requiring robust antennas with low variability or antennas capable of monitoring one or more parameters, in addition to

transmitting or receiving radio frequency signals, will all benefit from the present apparatus.

The apparatus will now be described in conjunction with the figures. With reference first to Fig. 1, one embodiment of a radio frequency sensing system includes a radio frequency control unit **102** in communication with a process control unit **104**, one or more radio frequency probes **106**, a microwave resonant cavity **108**, and cables **110**. The radio frequency control unit **102** may contain a radio frequency transmitter, receiver, and related components required to conduct the radio frequency measurements. The process control unit **104** may be an engine control unit or any other suitable process control unit, but may or may not be required, depending on the application. One or more radio frequency probes **106** may be in communication with the radio frequency control unit **102** through one or more cables **110**. In one embodiment a cable **110** may be integrated into radio frequency probe **106** without the use of any additional connectors. The radio frequency probe **106** may be a rod antenna, loop antenna, waveguide, or any other suitable means for transmitting or receiving a radio frequency signal. Microwave resonant cavity **108** may be catalyst housing or particulate filter housing in one example, and may or may not contain inlet or outlet portions to enable material to enter or exit the cavity. Microwave resonant cavity **108** may or may not be required depending on the application. In another embodiment, radio frequency control unit **102** may be integrated directly into radio frequency probe **106** without use of cable **110**. In yet another embodiment, process control unit **104** may be integrated into radio frequency control unit **102** or vice

versa. One or more interconnects may be used along the length of cable **110** between radio frequency control unit **102** and radio frequency probe **106** or no interconnects may be used. Cable **110** may be a coaxial cable, twisted pair, may or may not contain shielding, or may be another other single or multi-conductor cable.

Radio frequency probe **106** may or may not contain additional sensing elements such as temperature sensors (thermocouple, thermistor, RTD, fiber optic), pressure sensors, strain gauges, gas sensors, moisture sensors, accelerometers, position sensors, and the like, generically referred to as ancillary sensors. One or more ancillary sensors may be integrated into radio frequency probe **106** to provide independent measurements of parameters or state variables in addition to the radio frequency signal which may be transmitted or detected by radio frequency probe **106**. The ancillary sensing electronics, such as a thermocouple or RTD circuit chip, (integrated circuits such as those produced by Maxim in one example), pressure sensing electronics, signal conditioning, wheatstone bridges, and the like may also be contained in radio frequency control unit **102** or process control unit **104** or radio frequency probe **106**. The signals from ancillary sensors may be transmitted through additional conductors or the same conductors contained in cable **110**. In the case where the same cable is used, a series of switches in radio frequency control unit **102** may be used to alternately isolate the radio frequency signal and electronics from the ancillary sensing signal and electronics. In another embodiment, additional cables for the ancillary sensors may be used or additional conductors in cable **110** may be used.

Fig. **2A** presents one exemplary embodiment of radio frequency probe **106** shown in Fig. **1**. The probe in Fig. **2A** includes a coaxial cable **202**, outer sleeve **204**, and inner conductor **206**. The outer sleeve **204** and the inner conductor **206** are both made of a conductive material. The outer sleeve **204** and inner conductor **206** may or may not be of the same material. In one embodiment outer sleeve **204** and inner conductor **206** may be copper, gold, silver, steel, aluminum, stainless steel or similar alloys, such as inconel, but any suitable material may be used. In another embodiment, outer sleeve **204** and inner conductor **206** may be fully or partially encased or enclosed in a non-conductive material **205**, such as ceramic, glass, plastic (for low temperature applications) or the like. The casing may serve to prevent contamination of the probe or otherwise physically separate inner conductor **206** or outer sleeve **204** from the surrounding environment, but still permit transmission or reception of a radio frequency signal. The encasing non-conductive material **205** may or may not be porous.

Although shown as a tube, the outer sleeve **204** can have different topologies: it can be contoured or corrugated, have groves or ridges, as in helically or spirally corrugated conductor, or bellow-like shape. Similarly, inner conductor **206** can have multiple cross sections.

Additional details of the probe assembly are shown in the cut-away view in Fig. **2B**. Outer sleeve **204** may be connected to outer insulating jacket **208** of coaxial cable **202** by means of a mechanical or chemical bond or connection.

In one embodiment, outer sleeve **204** may be connected to the outer insulating jacket **208** by means of one or more second crimp connections **214**. Adhesive or sealant (not shown) may or may not be used to facilitate the connection. In this manner, a conventional coaxial cable may be terminated with an antenna probe connection, suitable for transmitting or receiving radio frequency signals.

The coaxial cable **202** includes an outer insulating jacket **208**, and a coaxial braid **210**. The coaxial cable **202** may be RG58 or RG400 or any other type of coaxial cable meeting the application requirements. Additionally, as shown in Fig. **2C**, the coaxial cable **202** also comprises an inner dielectric material **220** disposed between the inner conductor **206** and the coaxial braid **210**. An inner sleeve **212** is also shown, inserted below the coaxial braid **210**. The inner sleeve **212** is preferably a rigid, cylindrical, and electrically conducting material. In one embodiment, the inner sleeve **212** has an inner diameter the same as that of the coaxial braid **210**, however the diameter may be larger or smaller in other embodiments. The inner sleeve **212** may or may not be knurled or contain other surface features (roughness, threads, spirals, ridges or the like) to increase the contact area and facilitate a robust connection between the inner sleeve **212** and the coaxial braid **210**. Further, the inner sleeve **212** may or may not be connected to outer sleeve **204**.

Fig. **2C** and **2D** present another embodiment showing additional details and a cut-away view of a system in which outer sleeve **204** contains an integrated inner sleeve portion **212** as a single component. In this embodiment, the

inner diameter **222** of inner sleeve portion **212** may or may not be the same as inner diameter **224** of the outer sleeve portion **204**. Further, in this embodiment, inner sleeve portion **212** is inserted below coaxial braid **210** but above inner dielectric material **220** of coaxial cable, as shown in Fig. **2D**. Figure 2C shows a first step in which outer sleeve **204** is first positioned over inner conductor **206** and before coaxial braid **210**, and Figure 2D presents a second step where inner sleeve **212** is slid below coaxial braid **210** prior to crimping.

Once assembled, the outer sleeve **204** is crimped over the inner sleeve **212** with first crimp connections **216** and over the outer insulating jacket **208** with second crimp connections **214**. A variation not shown in Fig. **2B** has the inner sleeve **212** as integral part of the outer sleeve **204**, with first crimp connections **216** and second crimp connections **214** being as a separate sleeve, allowing for ease of placement of the coaxial braid **210** over the inner sleeve **212**.

In one example, crimped portion of outer sleeve **204** may be separate from the remainder of outer sleeve **204**. In another embodiment, inner sleeve **212** may be a separate component from outer sleeve **204** prior to assembly, but may be in electrical contact with outer sleeve **204** following assembly.

In another embodiment, the inner sleeve portion **212** may have an inner diameter **222** equivalent to that of the inner diameter of the coaxial braid **210** and the inner diameter **224** of the outer sleeve portion **204**. In one embodiment, the inner diameters **222**, and **224** and the inner

diameter of coaxial braid 210 may be configured to ensure correct impedance matching of the outer sleeve 204 to the coaxial cable 202. In another embodiment, the impedance matching may be affected by the inner diameters 222, and 224 and the inner diameter of coaxial braid 210 and by the inner dielectric material 220 of the coaxial cable 202 and any dielectric material located within the region bounded or enclosed by outer sleeve 204. In one example, the ratio of the inner diameter 224 of outer sleeve 204 to the outer diameter of inner conductor 206 may be approximately 2.3:1. In yet another example, the ratio of the inner diameter 224 of outer sleeve 204 to the outer diameter of inner conductor 206 may be a function of the dielectric material fully or partially contained within outer sleeve 204, designated as cavity 218 in Fig. 2. The impedance match may be for a 50 Ohm or 75 Ohm cable or any other impedance.

Regardless of whether inner sleeve 212 is connected to outer sleeve 204 (as in Fig. 2C and 2D) or not connected to outer sleeve 204 (as in Fig. 2B), the inner sleeve 212 serves as a rigid support to ensure good electrical contact between the outer sleeve 204 and the coaxial braid 210 of the coaxial cable 202. In one embodiment, a first crimp connection 216 (see Fig. 2B) may be used to mechanically compress outer sleeve 204 onto coaxial braid 210, which is supported internally by inner sleeve 212. In this manner, electrical continuity is ensured between the coaxial braid 210 and outer sleeve 204 of the probe.

One or more second crimp connections 214 (see Fig. 2B) may be made to secure outer sleeve 204 to outer insulating jacket 208 of coaxial cable 202. The second crimp

connections **214** may or may not be required. Adhesives or other suitable bonding or sealing agents may also be applied to enhance the strength of the connection between outer insulating jacket **208** of coaxial cable **202** and outer sleeve **204**. Many crimping options exist; for example, a hexagonal crimping tool can be used for performing the crimping operations, or other tools or crimping methods.

The region between inner conductor **206** and outer sleeve **204**, identified as cavity **218**, in Fig. **2B**, may or may not be filled with a suitable dielectric material. In one embodiment, high temperature mat material, such as intumescent fibers, may be used to completely or partially fill cavity **218**. In a particular embodiment, the material may exhibit similar characteristics to intumescent mounts produced by 3M and commonly used for mat mounts in particulate filter and catalysts assemblies. In another embodiment, the material may be non-intumescent. Various other materials including ceramics, glass, polymers, and related materials may also be used to completely or partially fill cavity **218**, depending on the requirements of the application.

The addition of material to cavity **218** serves several purposes. First, it ensures that inner conductor **206** remains centered in outer sleeve **204**. Second, it increases the strength of the overall probe assembly, and prevents loosening of inner conductor **206** from the probe assembly. Third, it may act to form a seal and prevent introduction of foreign matter, including gases, liquids, or other solid matter into probe assembly.

Inner conductor **206** may be integral to the coaxial cable **202**, such that it is the central conductor of the cable assembly. Inner conductor **206** may or may not be of the same material as the coaxial braid **210**. In one embodiment, outer insulating jacket **208**, coaxial braid **210**, and inner dielectric material **220** may be stripped to expose a specified length of inner conductor **206**. In another embodiment, inner conductor **206** may be fully- or partially encased in a sheath, which may or may not be conducting. The sheath may serve to reinforce and protect inner conductor **206**.

Figs. **3A-C** depict a series of steps to better illustrate the details of the assembly and construction of the coaxial cable with integral radio frequency probe. With reference now to Fig. **3A**, one end of a coaxial cable **202** is shown, which includes an outer insulating jacket **208**, a coaxial braid **210**, an inner dielectric material **220**, and an inner conductor **206**.

First, the coaxial cable **202** is stripped to reveal the internal components, namely coaxial braid **210**, inner dielectric material **220**, and inner conductor **206**. In one embodiment, the coaxial cable **202** is stripped such that the inner conductor **206** is exposed and of a sufficient length to be as long, or slightly longer than the desired inner conductor sheath **312** of the antenna. Inner conductor sheath **312** may be copper, aluminum, stainless steel, steel, iron silver, or gold, inconel or any other suitable material. Inner conductor sheath **312** may be a tube and may or may not be conducting. Next, inner sleeve **212**, which may or may not be knurled or exhibit a textured surface, is

slid over exposed inner conductor **206** and inner dielectric material **220** but under coaxial braid **210**, such that coaxial braid **210** covers all or nearly all of inner sleeve **212**.

In a following step, shown in Fig. **3B**, inner conductor sheath **312** of the antenna is slid over inner conductor **206** of coaxial cable **202**. In one embodiment, inner conductor sheath **312** is a metallic tube (composed of suitable metal alloy, such as a type of stainless steel or any other suitable alloy), which may or may not be closed at one end, with an inner diameter similar to that of the outer diameter of inner conductor **206**. Inner conductor sheath **312** may or may not be fastened to inner conductor **206** by crimping at one or both ends or anywhere along the length of inner conductor sheath **312**. In another embodiment, high temperature solder, brazing, or welding is used, to join inner conductor sheath **312** to inner conductor **206**. In yet another embodiment, connection of inner conductor sheath **312** and inner conductor **206** is facilitated by first heating inner conductor sheath **312** to increase the internal diameter of inner conductor sheath **312** by means of thermal expansion, before sliding inner conductor sheath **312** over inner conductor **206**. Many other methods may also be used to join inner conductor **206** and inner conductor sheath **312**.

In another embodiment, inner conductor **206** may extend fully through inner conductor sheath **312**, such that inner conductor **206** protrudes from the distal end of inner conductor sheath **312**. In this embodiment, inner conductor **206** may be folded over, flattened, or otherwise formed into a shape or position to prevent inner conductor sheath **312** from sliding off inner conductor **206**.

The addition of inner conductor sheath **312** over inner conductor **206** serves to increase the rigidity of inner conductor **206**, and also acts as a protective sheath, thereby protecting inner conductor **206** from harsh environments. Further, completely surrounding inner conductor **206** by the protective sheath formed by inner conductor sheath **312** provides a large amount of surface area to ensure good electrical contact between inner conductor **206** and inner conductor sheath **312**.

In a following step shown in Fig. **3C**, outer sleeve **204** is slid over inner conductor **206** and over exposed coaxial braid **210**. In another embodiment (not shown), inner sleeve **212** may be integrated into outer sleeve **204** such that the two individual components shown in Fig. **3A** form a single component exhibiting the same functionality and features of the two individual components. Fig. **3B** shows inner sleeve **212** positioned under coaxial braid **210** but over the inner dielectric material **220**. Inner sleeve **212** may or may not be connected to outer sleeve **204**.

In Fig. **3C**, outer sleeve **204** is shown positioned over exposed coaxial braid **210**, and may or may not extend over a portion of the outer insulating jacket **208**. In a first step, with reference to Fig. **3C**, outer sleeve **204** is fixed to coaxial cable **202** by means of one or more crimp connections, with at least one first crimp connection **216** positioned over exposed coaxial braid **210** and inner sleeve **212** such as to create a secure mechanical connection between coaxial cable **202** and outer sleeve **204**, and to create an electrically conducting path between coaxial braid **210** and outer sleeve **204**. Adhesives, sealants, or

other type of bonding materials may or may not be applied to further fix outer sleeve **204** to coaxial cable **202**.

It should be noted that outer sleeve **204** need not extend beyond exposed coaxial braid **210** in some embodiments. In a particular embodiment (not pictured), exposed coaxial braid **210** and inner dielectric material **220** may extend through the full length of outer sleeve **204**. In this embodiment, internal diameter of outer sleeve **204** may be of nominally the same diameter, or slightly larger, than the outer diameter of coaxial braid **210**. Inner sleeve **212** may or may not be used in this embodiment, or in any of the aforementioned embodiments. In yet another embodiment, coaxial braid **210** may extend the full length of outer sleeve **204** but inner dielectric material **220** may not. These particular variations of the embodiment depicted in Figure 3, namely variations in the length of coaxial braid **210** and inner dielectric material **220** within outer sleeve **204** may be preferred in some cases.

The fully-assembled radio frequency probe is shown in Fig. **3C**, which includes outer sleeve **204** securely fastened to coaxial braid **210** and outer insulating jacket **208**, as well as inner conductor **206** completely encased in inner conductor sheath **312**. In cases where coaxial braid **210** and inner dielectric material **220** do not extend to the end of outer sleeve **204**, the void cavity formed between the outer diameter of the inner conductor sheath **312** and the inner diameter of the outer sleeve **204** may or may not be fully- or partially-filled with a dielectric, insulating, or sealing material. Further, the geometry of the probe assembly shown in Figure 3, in particular the selection of

the inner diameter of outer sleeve **204**, outer diameter of the inner conductor sheath **312**, and the dielectric, insulating, or sealing material contained in the region bounded thereby (if present) should be selected to match the impedance of the system for which the antenna probe and cable assembly will be used. In one embodiment, an impedance of 50 ohms is used, although any impedance may be used such that it matches the design specifications of the system.

Fig. **4A** and **4B** present additional details of a particular embodiment of a radio frequency probe according to the present invention. The embodiment includes a coaxial cable **402**, external sealing component **404**, outer sleeve **406**, exposed coaxial outer braid **408**, inner sleeve **410**, sealing or adhesive compound **412**, mating components **414** and **416** and inner conductor **418**. External sealing component **404** may or may not be used. In one embodiment, external sealing component **404** is a heat shrink tube, sealing tape, or other suitable component for forming a seal around coaxial cable **402** and outer sleeve **406**. External sealing component **404** may or may not facilitate heat transfer. Internal sealing or adhesive compound **412** may or may not be used. In one embodiment, internal sealing or adhesive compound **412** may be a one- or multi-part epoxy, silicone, polymer, or similar material, used to enhance the strength and stability of the transition between the inner conductor of the coaxial cable (not pictured) and the inner conductor **418**.

An interface consisting of two mating components **414** and **416** is also shown, which enables connection of the

radio frequency probe to the measurement system. In one embodiment, mating components **414** and **416** may form a conventional compression fitting. In another embodiment, mating components **414** and **416** may form a conventional threaded fitting. In yet another embodiment, mating components **414** and **416** may not be threaded at all, but allow for a secure connection using any number of conventional means. In yet another embodiment, mating components **414** and **416** may not be used at all, and outer sleeve **406** may be fixed to surface **420** by soldering, welding, or any other means.

In one embodiment, mating component **416** may be permanently fixed to the measurement system, such as surface **420**. Mating component **414** may be allowed to freely rotate around outer sleeve **406**. A flange, ferule (such as with a conventional compression fitting), or other rigidly mounted stop may also be attached to outer sleeve **406** or integrated into the receiving mating component **416** to ensure correct antenna alignment and insertion depth. In another embodiment, mating component **416** may contain a through hole of two different diameters to provide an internal stop. Integration of such features prevents errors induced by incorrect antenna installation, or improperly tightening the connection. Such errors are not easily avoided with the use of only simple threaded connections. Further, allowing mating component **414** to freely rotate around outer sleeve **406** prevents rotation of outer sleeve **406** and coaxial cable **402** during probe removal and installation.

Fig. **5A** is a probe with integrated ancillary sensor **514**, including outer insulating jacket **502**, coaxial braid **506**, first and second adapter rings **504** and **516**, outer sleeve **508**, inner conductor sheath **510**, inner conductor **512**, where integrated ancillary sensor **514** is wrapped around inner conductor **512** and contained within inner conductor sheath **510**. The integrated ancillary sensor **514** may be any type of sensor. Fig. **5B** shows a similar probe without an integrated ancillary sensor, but with the first and second adapter rings **504** and **516**. Wrapping ancillary sensor **514** around inner conductor **512** ensures tight and continuous contact with inner conductor sheath **510** enhancing the mechanical rigidity and fit. While the ancillary sensor **514** is shown as wrapped around inner conductor **512**, other embodiments are possible, where the ancillary sensor **514** is disposed proximate the inner conductor **512**.

A radio frequency probe with an integrated temperature sensor is shown in Fig. **6A**. The probe is capable of transmitting and receiving radio frequency signals and measuring temperature near the tip of the probe. The probe includes a coaxial cable **602**, an outer sleeve **604** in electrical contact with an exposed portion of the coaxial braid **618**, a series of concentric spacer rings **606** and **608**, an insulated covering **610**, an ancillary sensor **612**, such as a thermocouple or other sensor, an inner conductor **614**, and an inner conductor sheath **616**.

Concentric spacer rings **606** and **608** may or may not be required. The concentric spacer rings **606** and **608** enable the transition from the coaxial cable **602** to an outer sleeve **604** of larger internal diameter than the coaxial

braid **618**, while still maintaining electrical contact between the coaxial braid **618** and outer sleeve **604**. In addition, concentric outer spacer ring **608** contains a slit to allow ancillary sensor insulating sheath **610** and ancillary sensor **612** to pass through. One or more ancillary sensors **612** may be integrated into the radio frequency probe shown in Fig. **6A** in this manner. The diameter and thickness of the concentric spacer rings **606** and **608** may be suitably chosen to form the required transition from the outer diameter of the coaxial braid **618** to the inner diameter of the outer sleeve **604**. In some embodiments, only one spacer ring may be required, and in other embodiments, no spacer rings may be required.

In the embodiment shown in Fig. **6A**, the concentric inner spacer ring **606** is crimped onto the coaxial braid **618**. Not pictured is an inner sleeve below the braid, such as inner sleeve **212** in Fig. 3, which may or may not be required. Concentric outer spacer ring **608** contains a slit allowing ancillary sensor insulating sheath **610** to pass through. Outer sleeve **604** is shown crimped on to concentric outer spacer ring **608**.

Ancillary sensor insulating sheath **610** is used to prevent electrical contact between a metallic ancillary sensor **612** (such as a thermocouple or RTD sheath in one embodiment, with a particular example being a type K thermocouple with an outer sheath diameter between 0.01" to 0.125") and the coaxial braid **618** or outer sleeve **604**. The ancillary sensor insulating sheath **610** may be conventional heat shrink tubing, fiber glass wool, a polymer coating, or any other suitable insulating material.

Ancillary sensor **612** may include a single sheath containing thermocouple wires (not pictured) for any type of thermocouple, with a preferred type being Type K, and a preferred sheath material being inconel (or any suitable alloy), however, any type of appropriate thermocouple and sheath may be used. In one embodiment, the diameter of ancillary sensor **612** ranges from 0.01 to 0.062 inches, but may be larger or smaller in other cases. An example of such a sensor is the KMQXL-020-12 thermocouple sold by Omega, however any suitable thermocouple of similar design may be used. In another embodiment, the ancillary sensor **612** is an RTD sensor, thermister, pressure sensing element, strain gauge, or any other ancillary sensor.

Ancillary sensor **612** may be wrapped around inner conductor **614** contained within inner conductor sheath **616**. Ancillary sensor **612** may extend to the end of inner conductor sheath **616** or any desired intermediate position within inner conductor sheath **616**. In the case of a thermocouple or RTD, the sensing junction or location in ancillary sensor **612** is at the tip or end of the ancillary sensor **612** or at any other preferred position. Ancillary sensor **612**, inner conductor **614** and inner conductor sheath **616** may be joined by crimping at one or both ends, or some intermediate position, or other mechanical or chemical means, such as by glue, solder, brazing, or other suitable means. Inner conductor sheath **616** may or may not be fully or partially filled with a material to enhance the bond between inner conductor sheath **616**, ancillary sensor **612**, and inner conductor **614**.

In another embodiment, ancillary sensor **612** need not be contained within inner conductor sheath **616** but may be wrapped around the exterior surface of inner conductor sheath **616** or run parallel to inner conductor sheath **616**. In yet another embodiment, ancillary sensor **612** may not be in contact with inner conductor **614** or inner conductor sheath **616** at all, but attached at any position along the inner surface of outer sleeve **604**. In the case where ancillary sensor **612** is positioned along or extending from the inner surface of outer sleeve **604**, ancillary sensor insulating sheath **610** and concentric spacer rings **606** and **608** may not be required, thereby simplifying the system.

The end of ancillary sensor **612** extending from the antenna assembly may be connected to any type of suitable connector or cable assembly (not shown) in one embodiment. In another embodiment, the cable connected to ancillary sensor **612** may be wrapped around the coaxial cable **602** to form an integrated ancillary sensor and coaxial cable assembly (also not shown) or a multi-conductor cable may be used.

Outer sleeve **604** may or may not extend past exposed coaxial braid **618**. In one embodiment, outer sleeve **604** may extend beyond exposed coaxial braid **618** and be mechanically or chemically fastened or bonded to coaxial cable **602**. Heat shrink or other type of sealing material may be used to seal the connection between outer sleeve **604** and coaxial cable **602** (not shown).

In yet another embodiment, ancillary sensor **612** may exit outer sleeve **604** through a hole located on the side of outer sleeve **604**, in which case, concentric spacer rings

**606** and **608** may or may not be required. The hole may or may not be sealed with a sealing compound or covered such as by a heat shrink tube or other similar covering.

Fig. **6B** presents another embodiment, where ancillary sensor **612** extends from the end of inner conductor sheath **616**. Yet another embodiment is shown in Fig. **6C** where ancillary sensor **612** is a resistance temperature detector (RTD) or similar sensor which extends from the end of inner conductor sheath **616**. Ancillary sensor **612** need not be a thermocouple or RTD at all, but may be any type of sensing element, including an optical fiber or probe.

An exploded view of the major components comprising the radio frequency probe with integrated temperature sensing element is shown in Fig. **7**. The components include a coaxial cable **602** with an exposed inner conductor **614** and exposed coaxial braid **618**, an ancillary sensor **612** wound around inner conductor **614**, a crimp support **605**, concentric inner spacer ring **606** and concentric outer spacer ring **608**, outer sleeve **604** and inner conductor sheath **616**. Not all the components shown in Fig. **7** are required, depending on the specific design and application. For example, crimp support **605** and concentric spacer rings **606** or **608** may not be required.

Concentric outer spacer ring **608** shows additional details, including the slit to allow ancillary sensor **612** to pass through to the exterior of outer sleeve **604**. Electrical isolation of ancillary sensor **612** is provided by ancillary sensor insulating sheath **610**. A small hole is also shown in concentric outer spacer ring **608** which may be used for a set screw or other suitable fastener (not

pictured) to be used to firmly connect the concentric spacer rings **606** and **608** and ensure good electrical contact between the coaxial braid **618** of the coaxial cable and concentric spacer rings **608** and **606**. Any type of connection, including crimp connections, solder or brazed connections, or other mechanical or chemical (adhesives, sealants) may be used to join outer sleeve **604** to exposed coaxial braid **618** or coaxial cable **602**. Crimp support **605** may or may not be used.

It should be noted however, that the inner conductor **614** and ancillary sensor **612** may be reversed such that inner conductor **614** is wrapped around ancillary sensor **612**, within inner conductor sheath **616**. In another embodiment, inner conductor **614** and ancillary sensor **612** may both be twisted about one another. Additional ancillary sensors may be twisted together in this manner and encased in inner conductor sheath **616**. In one embodiment, different types of ancillary sensors **612** may be used, and each ancillary sensor **612** may or may not have the same length within inner conductor sheath **616**.

The void space within inner conductor sheath **616** not occupied by ancillary sensors **612** or inner conductor **614** may or may not be filled with dielectric material, ceramic powder, conductive material, or the like in order to improve rigidity and mechanical strength of the inner conductor sheath **616**. The addition of dielectric material, sealant, spacer rings, spirally wound spacer, or other packing material into region **601**, shown in Fig. 6A, serves a number of benefits. First it provides additional mechanical and structural stability to fix the position of

the inner conductor sheath **616** containing ancillary sensor **612** and inner conductor **614** within outer sleeve **604**. Second, it may provide additional isolation and sealing of the ancillary sensor insulating sheath **610** from the outer sleeve **604** and inner conductor sheath **616**. Different types of material may be utilized to pack or fill region **601**. In one example, the back 5%-25% of the region **601** may be filled with a sealant or epoxy (nearest the coaxial cable **602**) with the remaining volume filled with a high temperature fibrous matting material or ceramic, in one embodiment. The sealant may fix the ancillary sensor insulating sheath **610** in place, preventing chafing or wearing away of the insulating material and also form an impervious seal to prevent the leakage of liquids, solids, or gases.

Fig **8**. shows a radio frequency probe connected to a coaxial cable **802** with integrated other types of sensors **812, 804, 808, 810** which may or may not be positioned as shown on or inside outer sleeve **814** or inner conductor **816**. Integrated other types of sensors **812, 804, 808, 810** may be any type of one or more sensor, such as pressure sensor, temperature sensor, optical sensor, gas composition sensor, membrane or diaphragm sensor, thin film sensor, resistive or capacitive sensor, or other type of sensing device.

The performance of two radio frequency probes with integrated temperature sensor is shown in Fig. **9**. The data in the figure was collected with two radio frequency probes containing integrated temperature sensors mounted in the inner conductor installed on opposite sides of a diesel particulate filter. The particulate filter was installed

in the exhaust system of a diesel burner. For comparison, a thermocouple was also installed in the exhaust pipe upstream of the particulate filter. Temperature curve **A** in Fig. 9 corresponds to the measured exhaust temperature in the exhaust pipe upstream from the particulate filter. Temperature curves **B** and **C** correspond to the temperature measurements from the radio frequency probes with integral temperature sensors mounted near the inlet and outlet of the filter, respectively. In both cases the temperature response of the radio frequency probes with integral temperature sensors tracks very well with changes in the exhaust gas temperature upstream of the filter system measured by the thermocouple at point **A**. Temperatures **B** and **C** are, however, lower than **A**, due to heat losses from the exhaust system between point **A** and the particulate filter.

Fig. 10 presents a comparison of the radio frequency transmission signal (S12) resonance curves corresponding to two identical antenna probes, one without a temperature sensor **D** and the other with an integrated temperature sensor **E**. There is no significant difference in the radio frequency performance of the probes **D** and **E** (less than 0.35% averaged over the resonance curve) due to the addition of the integrated temperature sensor. Similar measurements may also be conducted in reflection (S11 or S22).

In order to minimize variability from antenna and to provide simplicity, some of the RF electronics can be incorporated on the antenna. Fig. 11 shows a schematic of an antenna where the VCO or the source of the RF signal or

the detector is placed inside the antenna body, thus eliminating any connections between the RF electronics and the antenna after fabrication. In Fig. **11**, one end of the antenna **1110**, and the ground electrode **1120** of the antenna are shown. The RF element (source or detector) **1130** is grounded to the ground electrode **1120** through connector **1160**, and is connected to an outside electronic box **1140** via conduit **1150** that provides power and control to the RF element **1130**. The RF element **1130** is connected internally to both the antenna **1110** and a ground electrode **1120** (although in principle, both electrodes are acting as antennas). Although Fig. **11** shows the source of the RF, it could instead be the detector of the RF or a combined transmitter and detector. The antenna assembly can be long enough in order to locate the RF electronics away from environments that can damage the electronics (such as temperature).

Fig. **12A** shows a schematic where the antenna and the signal generator and additional RF electronics that are located inside the antenna assembly are surface mounted. The advantage of surface mounting the antenna and the other elements is both reduced cost of manufacturing as well as providing very reproducible antennas. Multiple antennas **1210** and **1220** can be placed in the unit **1260**, if desired. For example, the antennas **1210**, **1220** can be made using stripline techniques, or on a PC board **1240**, or alternative surfaces that can be produced using microfabrication techniques. Complex antennae **1210** can be used, if desired, with tight tolerances. The RF electronics **1230** can be mounted on the PC board **1240** such that they are removed

from environments that can be damaging to the electronics, such as temperature.

Fig. 12A shows a schematic where two antennae **1210** and **1220** are placed in the same unit (thus able to measure both S11 and S21 signals using a single unit **1260**). One can be the transmitting antenna while the second one could be the receiving antenna. Alternatively, they can be both transmitting (or receiving) antennae with different phases, for adjusting the characteristics of the launched (received) wave. The number of parts can be decreased while maintaining the flexibility of measuring both transmission and reflection. The RF electronics **1230** both has the capability for generating the RF as well as the sensing capability for detecting the reflected signal to the transmitting antenna or the transmitted signal to the second antenna. The outside electronic box unit **1285** is placed outside of the unit **1260**, and connected to the RF electronics 1230 through connector **1270**.

In order to provide protection, the antenna assembly can be surrounded by a sheath made from a dielectric material (such as a ceramic, alumina for high temperature applications or an organic material for low temperature applications) which can be an integral part of the antenna or it could be an external unit. If external, it could be straight-forward to replace the antenna elements and the RF electronics without exchanging the dielectric sheath. The power and control unit of the RF element can be located outside of the antenna assembly.

An alternative assembly is shown in Figure **12B**. Instead of a second antenna, there is a hollow conducting tube **1280** that serves as the second electrode. A number of arrangements exist that can provide advantages, such as replacing the antenna element **1210** by a second hollow tube. The RF electronics **1230** is grounded to the antenna ground through element **1290** (not shown in Fig. 12A).

One advantage of the embodiments described in Fig. **11-12** is the elimination of coaxial elements outside of the antenna, reducing costs and increasing reliability.

In addition to including the RF electronics onto the antenna, it is possible to include communication between the assembly and an external unit using wireless communication techniques. In this manner, the antenna is self-sufficient, without the needs of electrical connections to the external world. In this case, the antenna assembly needs to include a power source, which could be a battery. Some processing would be required to manage the data, using a processor on the antenna assembly.

The descriptions in FIGs. **11** and **12** are compatible with integrating other sensors onto the antenna assembly. Although dipole-like antennae are described, it would be possible to replace them with a loop or a series of loops. Also it would be possible to have multiple conducting elements in order to make phase-array antennae. In addition, the antennae may be a dielectric antennae, with dielectric elements for adjusting the frequency of operation, directionality of the emitted/received RF energy. Dielectric antennae are attractive because they could be

used in environments where conventional conductive antennae could be not appropriate (because of electrical hazard, temperature or corrosive environment, for example). Dielectric antennae could be fed from a microstrip line and manufactured with surface mounted electrical and dielectric elements.

Fig. 13 depicts a further embodiment where an ancillary sensor **612** is integrated into a radio frequency measurement probe. A coaxial cable **602** may be attached to an outer sleeve **604** whereby coaxial braid **618** is in electrical contact with outer sleeve **604** through a crimp connection, solder connection, compression connection, or any other suitable means. Coaxial cable **602** need not be a coaxial cable, but may be any cable, such as twisted pair in one example, which may terminate with one conductor in electrical contact with outer sleeve **604** and a second conductor forming inner conductor **614**.

Concentric spacer ring **608** may or may not be used. In the case where concentric spacer ring **608** is used, it may or may not contain a passage **1306** to enable wires or electrical conductors **1302** to pass through. Passage **1306** may contain an insulating material to insulate wires or conductors **1302** from each other and from outer sleeve **604** and from coaxial braid **618**.

The radio frequency probe shown in Figure 13 may contain an ancillary sensor **612**, which may be in direct electrical contact with inner conductor **614**. In one embodiment, inner conductor **614** may be wound around ancillary sensor **612**. The number of windings of inner

conductor **614** around ancillary sensor **612** may be used to control the degree or strength of electrical and mechanical coupling of the two components. In another embodiment, inner conductor **614** may not be wound around ancillary sensor **612** and may or may not be in electrical contact with ancillary sensor **612**.

Inner conductor sheath **616** may or may not be used and may or may not extend the full length along ancillary sensor **612**. In one embodiment, the region between inner conductor sheath **616**, ancillary sensor **612** and inner conductor **614** may or may not be filled with some material, such as insulating or conductive material. In one embodiment, inner conductor **614** may be in electrical contact with inner conductor sheath **616** but may not be in electrical contact with ancillary sensor **612**. In yet another embodiment, all three aforementioned elements may be in electrical contact. Inner conductor sheath **616** may or may not be conducting. In one embodiment, inner conductor sheath **616** may be metallic, such as stainless steel or Inconel. In another embodiment, inner conductor sheath **616** may be ceramic, glass, or plastic, or any other material.

When the ancillary sensor **612** is outside of a conducting inner conductor sheath, it is possible for the ancillary sensor **612** and conductors **1302** to act as an antenna extracting RF energy from the cavity and potentially irradiating outside of the system. It is desirable to prevent the RF energy from leaking from the system. It is possible to use capacitive elements, capacitive feedthroughs or magnetic elements (such as

ferrites or other EMI cores) to prevent radiation from leaking through the passage **1306**.

In one exemplary embodiment, ancillary sensor **612** may be a resistance temperature detector (RTD) or thermistor, but may be any sensor. Details of ancillary sensor **612** are shown in Figure **13** and show one or more conductors **1302** extending from a casing **1314** containing a sensing element **1312**. In one embodiment, sensing element **1312** may be a 200 Ohm platinum RTD, but may be any sensing element, including a thermocouple junction, piezo-electric element, strain gauge, or any other sensing element.

One or more conductors **1302** may be used to transmit the sensed signal or provide power or provide power and sense the signal from sensing element **1312**. Any number of conductors **1302** may be used. Conductors **1302** may connect sensing element **1312** to signal conditioning circuits or measurement circuits, chips, or equipment, not shown. In the case of an RTD or thermocouple, conductors **1302** may be connected to an integrated circuit chip such as a thermocouple or RTD chip produced by Maxim, in one example, but any suitable chip or circuit may be used to process and interpret the sensed signal.

In the case where inner conductor sheath **616** is used, conductors **1302** may pass through the inner conductor sheath **616** and be electrically isolated from inner conductor sheath **616** by means of passage **1308**. Conductors **1302** may or may not contain electrical insulation, such as a wire jacket or sleeve (not shown). The region **1304** within outer sleeve **604** may or may not be fully or partially filled with

epoxy, sealant, potting compound, dielectric material, ceramic or glass discs, powders, high temperature matting material, or the like. In one exemplary embodiment, the back 30% abutting the coaxial cable **602** of the region **1304** may be filled with high temperature epoxy potting material sufficient to fully encapsulate conductors **1302** and fill passages **1308** and **1306** to provide electrical isolation, vibration damping, additional support and a sealed connection. The remaining 70% of the region **1304** may contain a high temperature matting material, however any proportion and any type of material may be used, depending on the application.

In another embodiment, inner conductor sheath **616** may extend over ancillary sensor **612** the same length as outer sleeve **604**. Inner conductor **614** may only be wound around ancillary sensor **612** over the length covered by inner conductor sheath **616**. In this embodiment, the full length of ancillary sensor **612** is exposed beyond outer sleeve **604** to provide improved measurement sensitivity or response time. Inner conductor **614** may be in direct electrical contact with ancillary sensor **612**, thereby directly transmitting or receive the RF signal along the length of ancillary sensor **612**.

The system disclosed in Figure 13 has a number of advantages, specifically the high quality connection between inner conductor **614** and ancillary sensor **612** or inner conductor sheath **616**. In addition, fully or partially filling region **1304** with matting material, potting compound, or the like provides a robust and durable assembly. Passages **1308** and **1306** enable electrical

isolation of conductors **1302** from coaxial cable **602** and outer sleeve **604** and inner conductor sheath **616**. Passages **1306** and **1308** may be a hole, slit, or any suitable passage. Any number of conductors **1302** may be used, such as in a two-, three- or four-wire RTD, or any other type of sensor.

Outer sleeve **604** may further be in contact with conducting cavity walls, such as a filter or catalyst housing, or conduit, but may be in contact with any walls or surface. In another example, outer sleeve **604** may not be in contact with any surface. Inner conductor sheath **616** may or may not be sealed or terminated at the end and ancillary sensor **612** may or may not protrude from inner conductor sheath **616**. Inner conductor sheath **616** may or may not be connected to ancillary sensor **612** and inner conductor **614** by crimping, friction fit, solder, glue, or any other suitable means.

The operation of the radio frequency probe with integrated one or more ancillary sensors will now be described with reference to Figure 1. In one method of operation, radio frequency control unit **102** generates and sends a radio frequency signal at a single frequency or multiple frequencies to one or more radio frequency probes **106**. One or more radio frequency probes **106** may receive one or more radio frequency signals at one or more frequencies and transmit the received signal back to radio frequency control unit **102** by means of cable **110**. The signal may be transmitted or received in a microwave resonant cavity **108** or in free space.

Radio frequency control unit **102** may also contain integrated sensing and processing electronics to monitor the signal received from one or more ancillary sensors integrated into radio frequency probes **106**. In one example, the ancillary sensor **514** is a temperature sensor, which transmits a signal proportional to the sensed temperature to radio frequency control unit **102** via cables **110**, but any sensed parameter may be monitored and transmitted. Cables **110** may be a multi-conductor cable assembly or wiring harness.

In another embodiment, radio frequency control unit **102** processes measurements or signals received from the radio frequency probes (radio frequency signals) along with one or more ancillary sensed values. Radio frequency signals may be corrected or modified by radio frequency control unit **102** based on one or more ancillary sensed values from radio frequency probe **106**, such as multiplying or dividing the radio frequency signal by a correction factor. Any type of signal modification may be applied.

In one embodiment, one or more radio frequency signal parameters may be computed from the group consisting of quality factor, amplitude, frequency, frequency shift, phase, or some derivative of one or more of the aforementioned parameters. The radio frequency signal may or may not be at resonance. If at resonance, one or more resonant mode may be monitored. Additional statistics for the parameters may also be computed such as the mean, median, mode, standard deviation, or any other parameter.

Radio frequency control unit **102** may modify one or more of the radio frequency parameters or statistics based on one or more ancillary sensor values, such as temperature, pressure, flow, moisture measurements, gas composition measurements, or the like. The modification to the RF signal or calculated parameter may be via a single or multi-variable equation, transfer function, scaling factor, look-up table or the like. The modifications may be carried out by instructions, algorithms, or the like contained on a computer readable storage medium contained in radio frequency control unit **102** and executed by a processor disposed within the radio frequency control unit **102**. The output of the raw or corrected radio frequency and ancillary sensed signals may be transmitted or communicated to process control unit **104** over a cable or wireless communication technique. Process control unit **104** may or may not be used and may or may not be separate but may be integrated into radio frequency control unit **102** or vice versa.

In one exemplary embodiment, the computed RF signal parameter is modified by means of a multi-variable equation which includes at least one additional variable determined from ancillary sensor measurements integrated into radio frequency probe **106** in order to compute a final value of the form:

$$\text{Final Value} = f(\text{RF\_Parameter}, \text{Ancillary\_Sensor\_Value}),$$

where the final value is a function of both the RF\_parameter obtained from the RF probe and the value returned by the ancillary sensor.

In one particular embodiment, the equation may be:

$$\text{Final Value} = (\text{RF\_Parameter})(A) + (\text{Ancillary\_Sensor\_Value})(B)$$

However any number of additional ancillary sensor values or measurements and RF parameters may be used, and the equation may be first order or higher order or any form (exponential, logarithmic, trigonometric). The variables A and B may be constants, or derived from a look-up table or other means. In another example, any number of constants or other variables may be used. In one example, the final value is the soot or ash level on a particulate filter or the quantity of a gas phase component adsorbed on a catalyst, but may be any final value. In another embodiment, the ancillary sensor value may be derived from a sensor not integrated into the radio frequency probe **106**, but in a preferred embodiment at least one ancillary sensor measurement is received from at least one ancillary sensor integrated into radio frequency probe **106**.

The final value determined by the radio frequency control unit **102** may be stored in radio frequency control unit **102** or used to initiate an action, such as to stop or start a process, trigger an alarm, or some other action.

In another method of operation, radio frequency control unit **102** conducts a plausibility, or on-board diagnostic, check of radio frequency probe containing integrated at least one ancillary sensor **612** (see Fig. **6**) to determine if the radio frequency transmission or reception is functioning correctly or whether or not the

ancillary sensor is functioning correctly. In one example, the plausibility check or self diagnostic determines whether the sensor or antenna has failed. The plausibility check may be carried out at a known steady state condition (reference condition) or by monitoring the transient response or change in the signal's behavior. In the case of the RF transmission or detection function, the plausibility check may determine whether the signal strength or amplitude, power, frequency, phase or some derivative thereof is outside and acceptable limit value. The same method may be applied to the ancillary second sensor value, which may be compared with a known reference condition or an external sensor not integrated into radio frequency probe **106**.

In one example, such as in the case of ancillary temperature sensor integrated into radio frequency probe **106**, the plausibility check may include measuring resistance through the sensor, comparing sensor measurements to a reference state, such as plausible ambient conditions, or monitoring the transient response of the sensor to some perturbation or comparing the temperature values to a values from a known second or third sensor. Any other measurement parameter or ancillary sensor may be diagnosed by radio frequency control unit **102** in this manner.

The benefits of the system and method disclosed herein include highly robust and repeatable RF measurements from a probe capable of conducting one or more additional ancillary measurements from the same probe assembly. Another advantage includes the correction or modification

of the RF signal based upon measurements of one or more ancillary sensors integrated into the same probe, as well as probe self diagnostics.

Although many of the examples cited in this disclosure relate to particulate filters, catalyst systems, and other emission control devices, the present apparatus may be applied to any type of system where radio frequency probes may be used, in any number of applications. Further, although the probes were described with reference to coaxial type cables, other types of cables, such as twisted pair may also be used.

While the above description contains much specificity, this should not be construed as limiting the scope of any embodiment, but as exemplifications of the presently preferred embodiments thereof. Many other ramifications and variations are possible within the teachings of the various embodiments.

Thus the scope of the invention should be determined by the appended claims and their legal equivalents, and not by the examples given.

What is claimed is:

1. A radio frequency probe system, comprising:
  - a coaxial cable having an inner conductor surrounded by an inner dielectric material, the inner dielectric material covered by a conducting coaxial braid, and the conducting coaxial braid covered by an outer insulating jacket;
  - a conductive outer sleeve in direct electrical contact with the coaxial braid; and
  - an inner conductor sheath encasing the inner conductor, extending beyond the outer conducting sleeve.
2. The system of claim 1, further comprising a conductive inner sleeve disposed between the inner dielectric material and the conductive coaxial braid.
3. The system of claim 1, further comprising one or more crimp connections, whereby the conductive outer sleeve is mechanically compressed to contact the coaxial braid.
4. The system of claim 1, wherein the inner conductor extends further than the inner dielectric material, the coaxial braid and the outer insulating jacket.
5. The system of claim 1, wherein the inner conductor sheath comprises a conductive material.
6. A radio frequency probe system, comprising:
  - a coaxial cable having an inner conductor surrounded by an inner dielectric material, the inner dielectric

material covered by a conducting coaxial braid, and the conducting coaxial braid covered by an outer insulating jacket;  
a conductive outer sleeve in direct electrical contact with the coaxial braid; and  
an ancillary sensor disposed proximate the inner conductor.

7. The system of claim 6, wherein the ancillary sensor is wrapped around the inner conductor.

8. The system of claim 6, further comprising a concentric inner spacer ring and a concentric outer spacer ring, wherein the concentric outer spacer ring comprises a hole through which the ancillary sensor passes.

9. The system of claim 6, wherein the ancillary sensor comprises a temperature sensor.

10. The system of claim 6, further comprising an inner conductor sheath encasing the inner conductor.

11. The system of claim 10, wherein the ancillary sensor is disposed in the inner conductor sheath.

12. The system of claim 10, wherein the ancillary sensor is wrapped around the inner conductor sheath.

13. A radio frequency measurement system, comprising:  
a coaxial cable having an inner conductor surrounded by an inner dielectric material, the inner dielectric material covered by a conducting coaxial braid, and

the conducting coaxial braid covered by an outer insulating jacket;  
a conductive outer sleeve in direct electrical contact with the coaxial braid;  
an ancillary sensor disposed proximate the inner conductor; and  
a radio frequency control unit in communication with the ancillary sensor, and function comprising a RF receiver in communication with the inner conductor.

14. The system of claim 13, further comprising a processor, wherein the processor calculates a final value of a parameter based on a received signal from the inner conductor and the ancillary sensor.

15. The system of claim 14, further comprising a microwave resonant cavity, wherein the inner conductor and the ancillary sensor are disposed within the microwave resonant cavity.

16. The system of claim 15, wherein the parameter comprises a soot or ash level on a particulate filter.

17. The system of claim 13, wherein the ancillary sensor comprises a temperature sensor.

18. A method for monitoring more than one parameter with a radio frequency probe, the method comprising:

transmitting or receiving a radio frequency signal with a radio frequency probe; and  
monitoring at least one additional parameter with a sensor integrated into a radio frequency probe.

19. The method of claim 18, wherein the one additional parameter comprises temperature.

20. The method of claim 19, wherein the one additional parameter is used to modify the radio frequency signal.

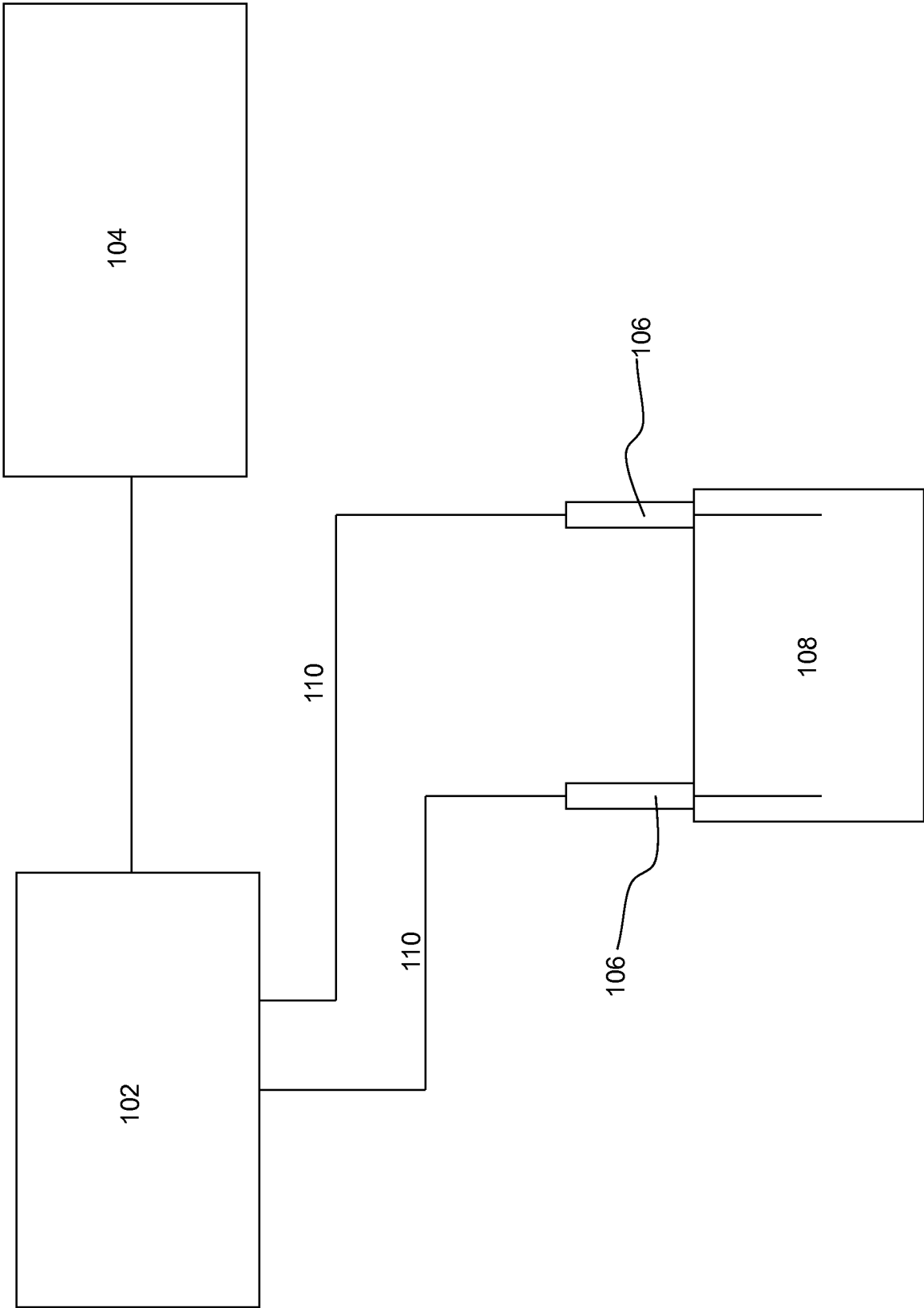

Figure 1

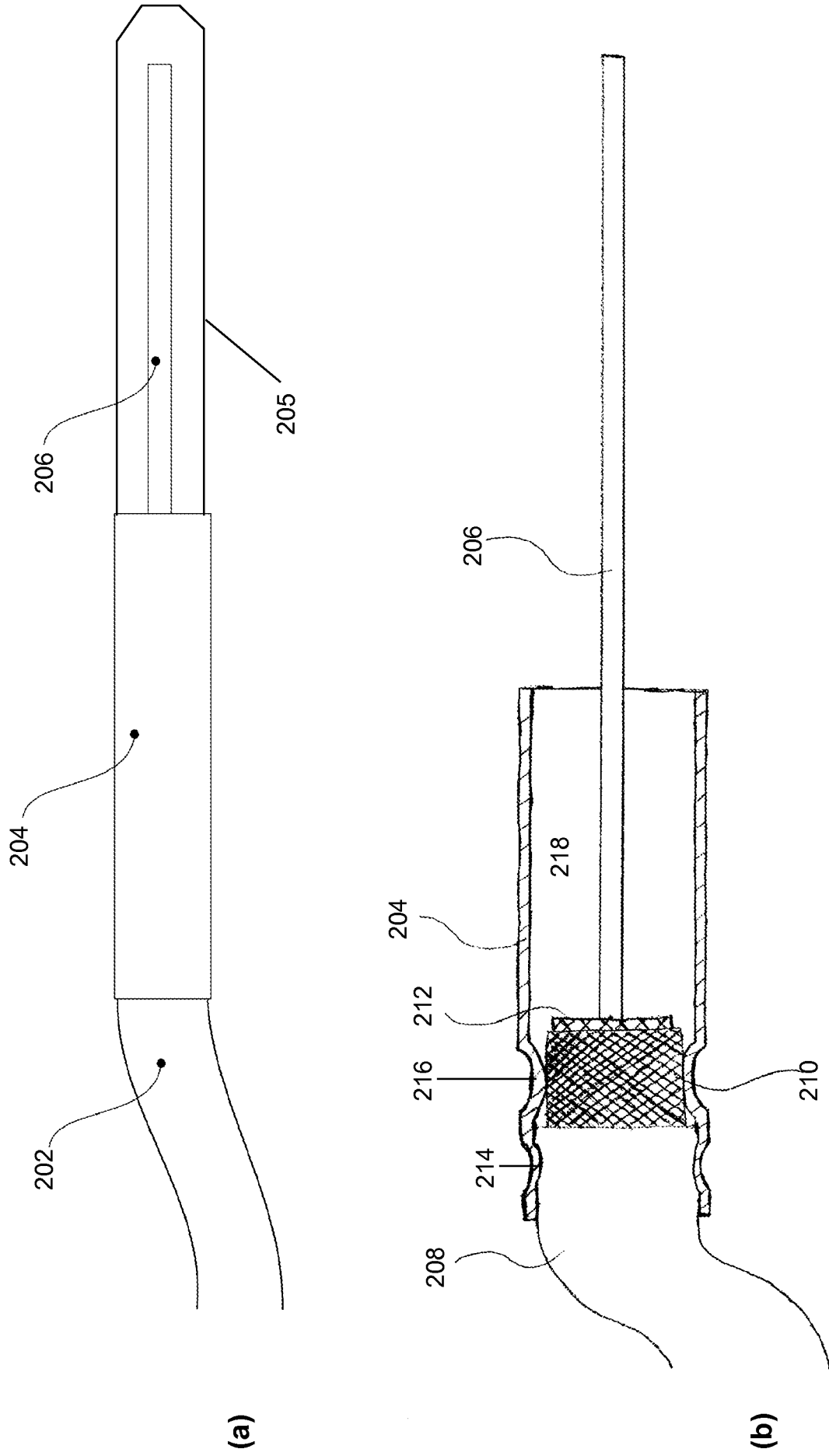

Figure 2

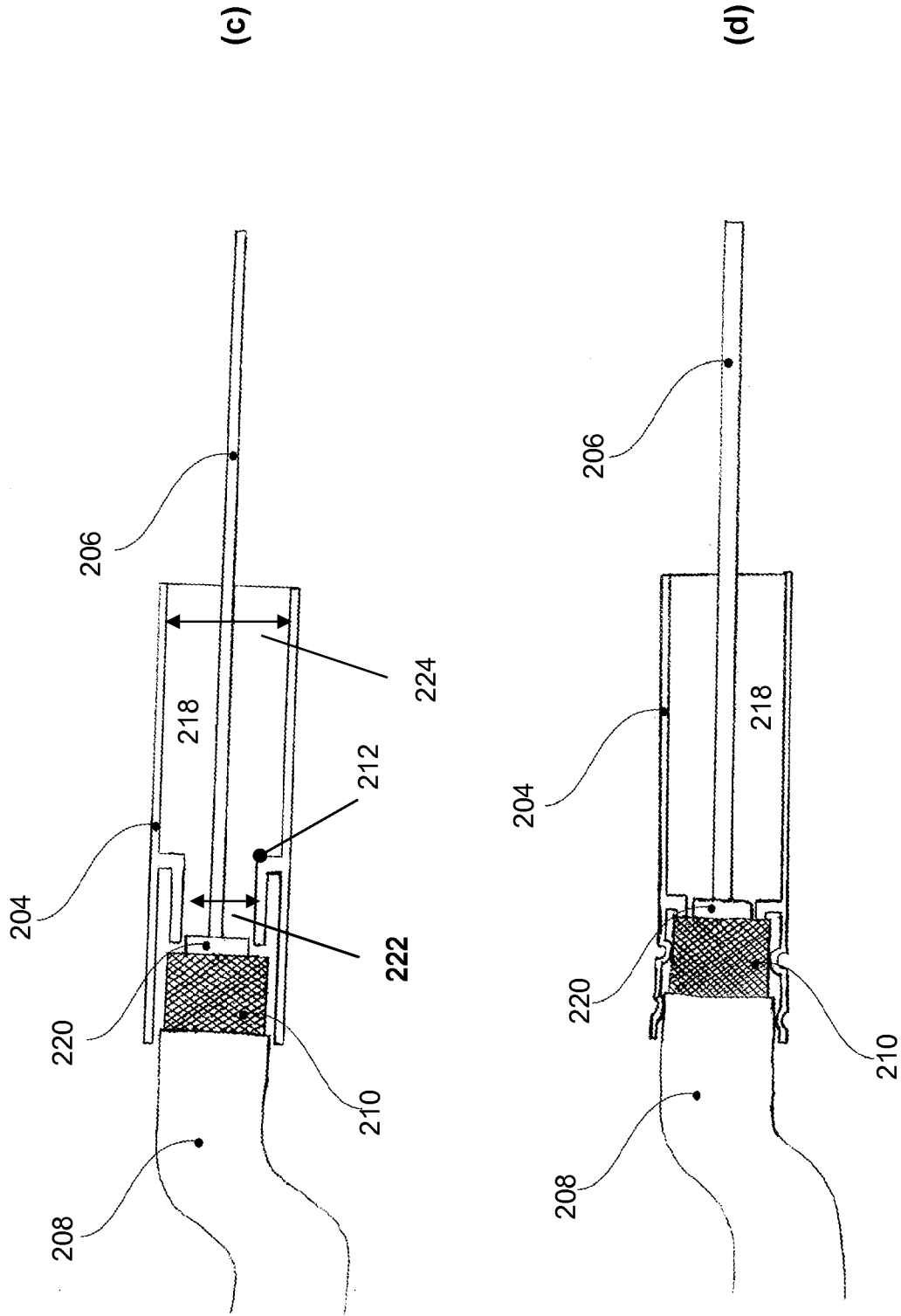

Figure 2

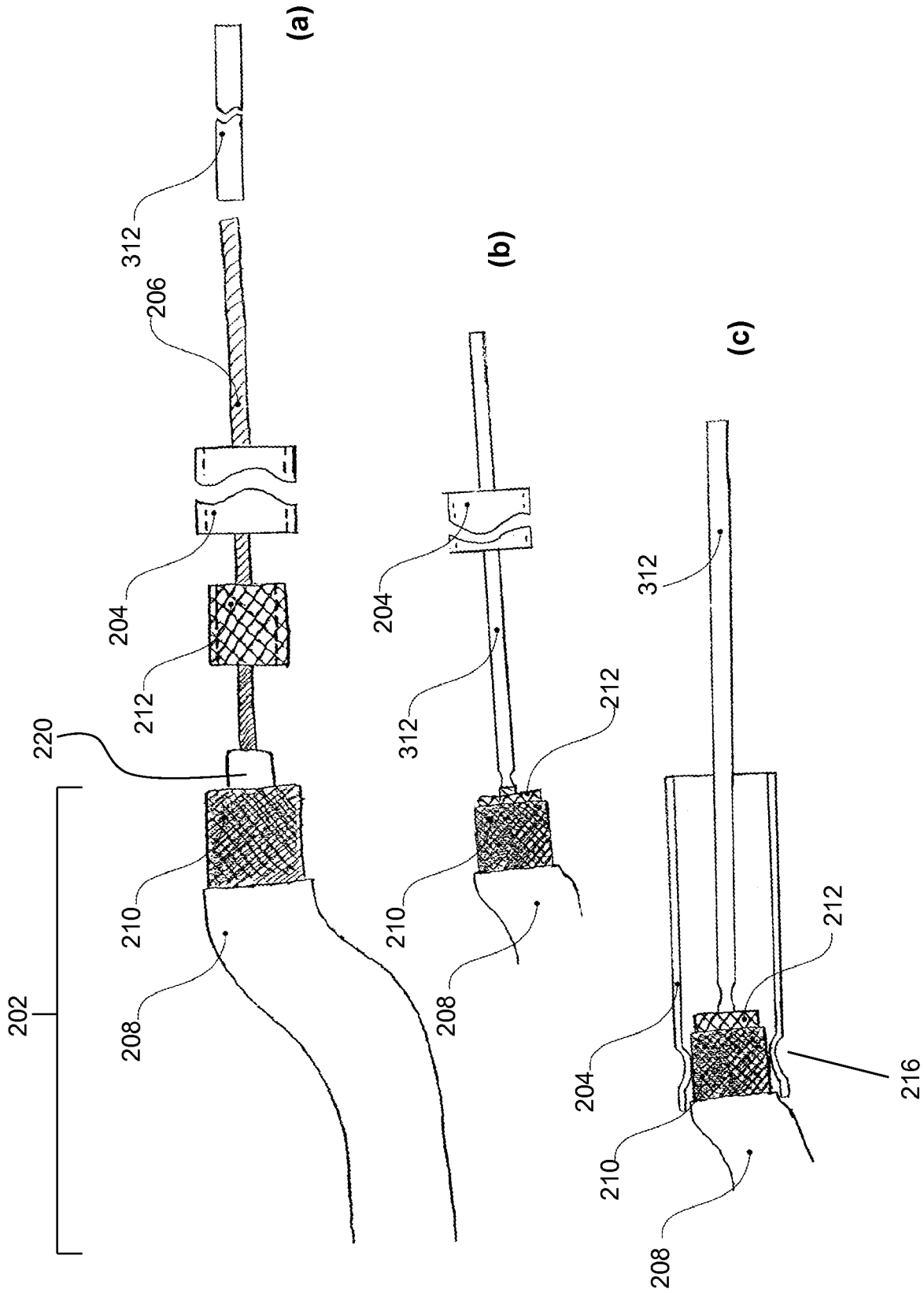

Figure 3

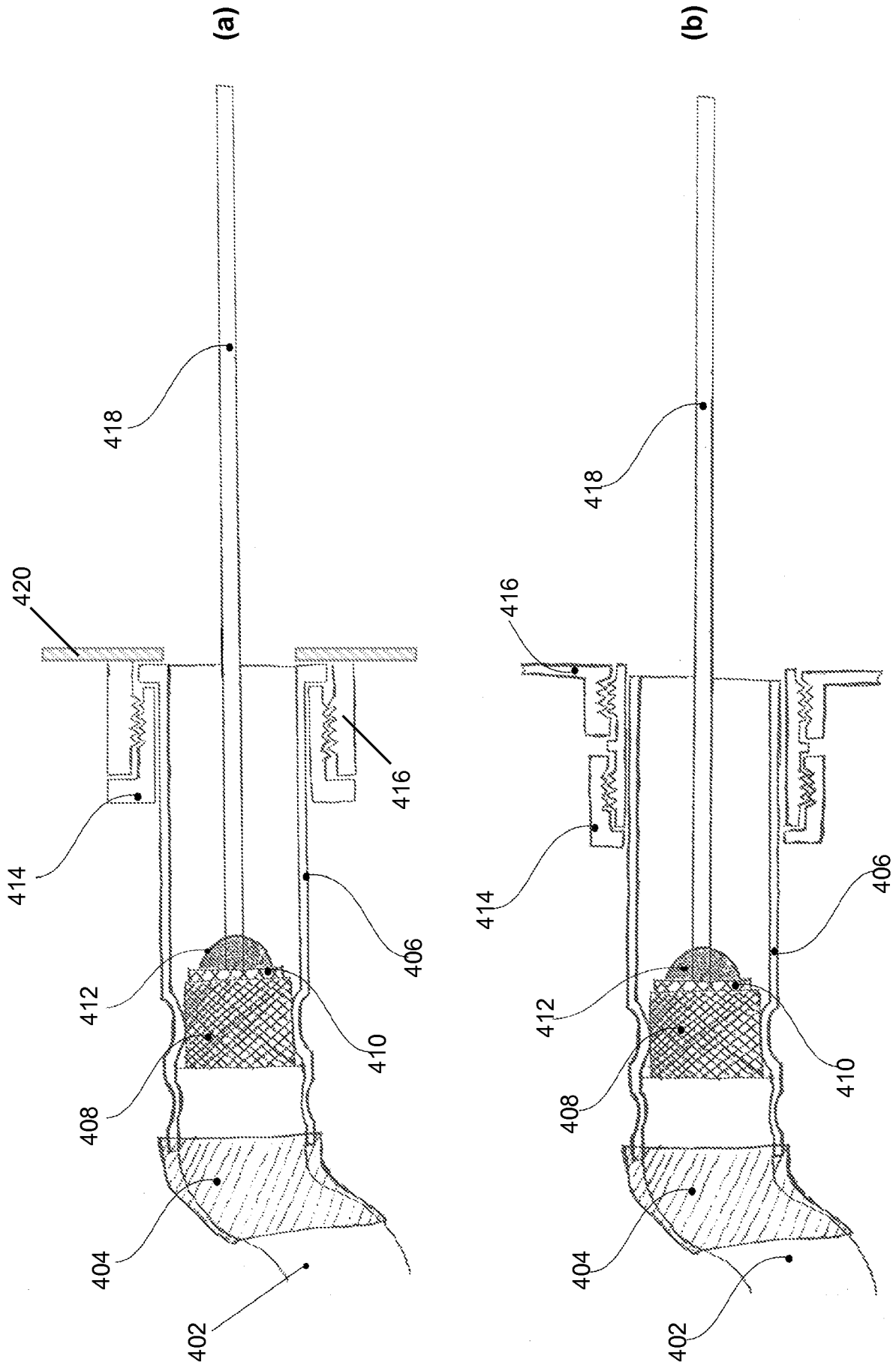

Figure 4

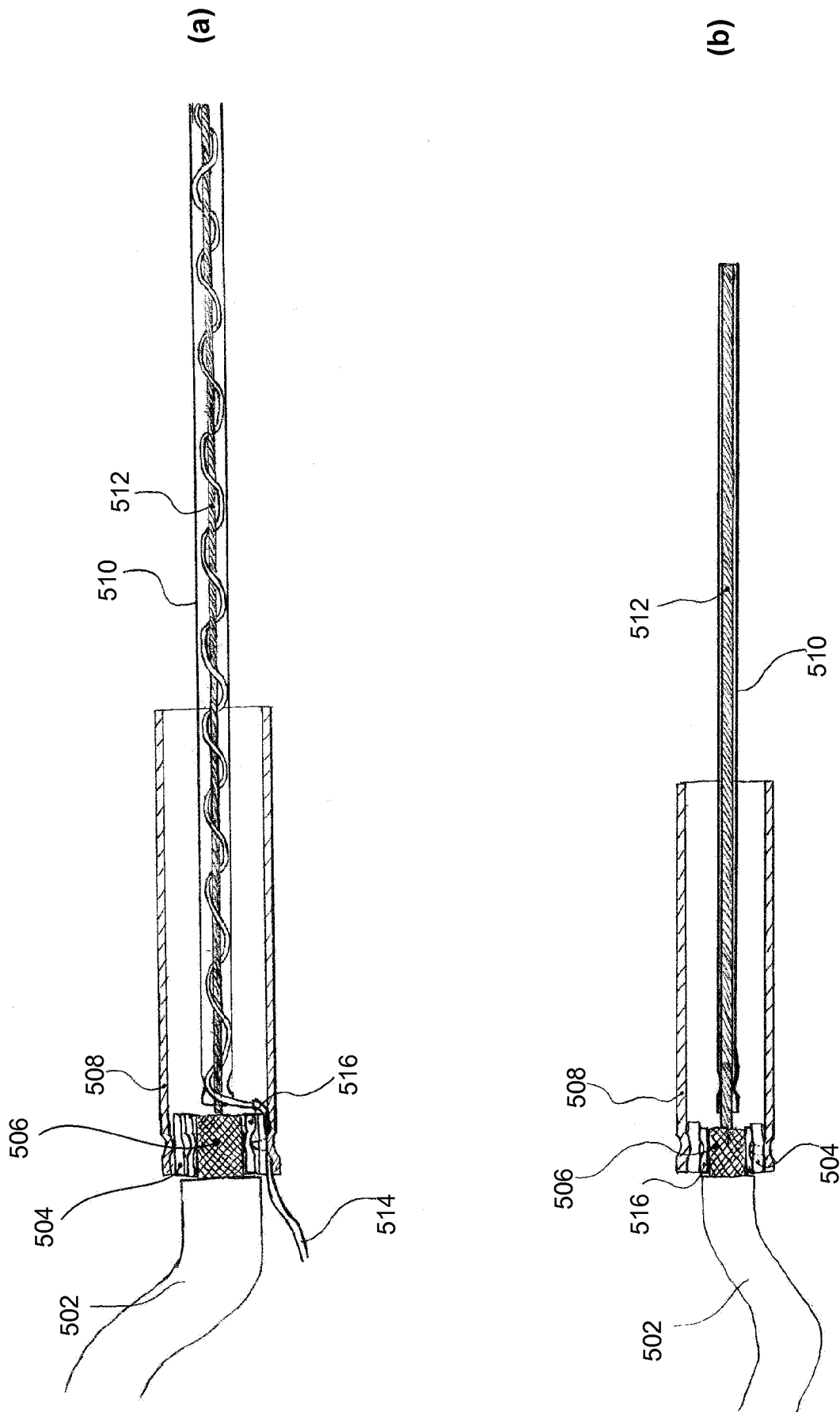

Figure 5

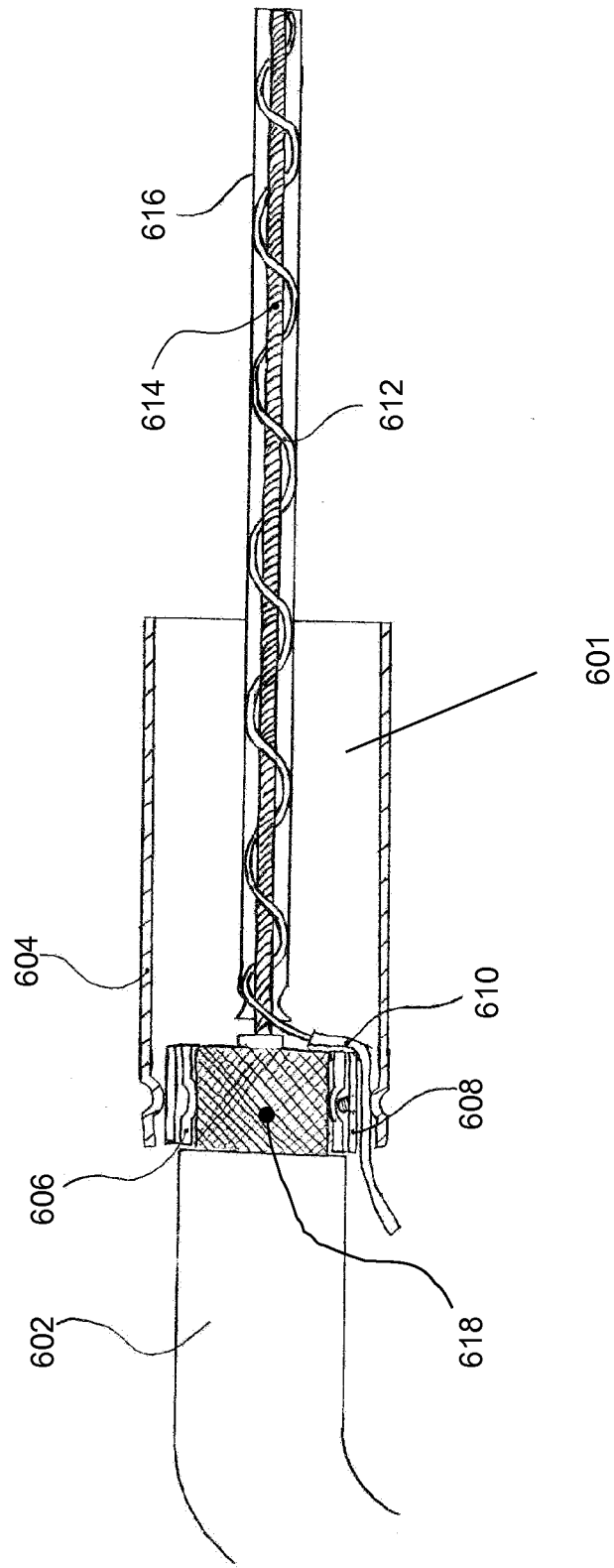

Figure 6A

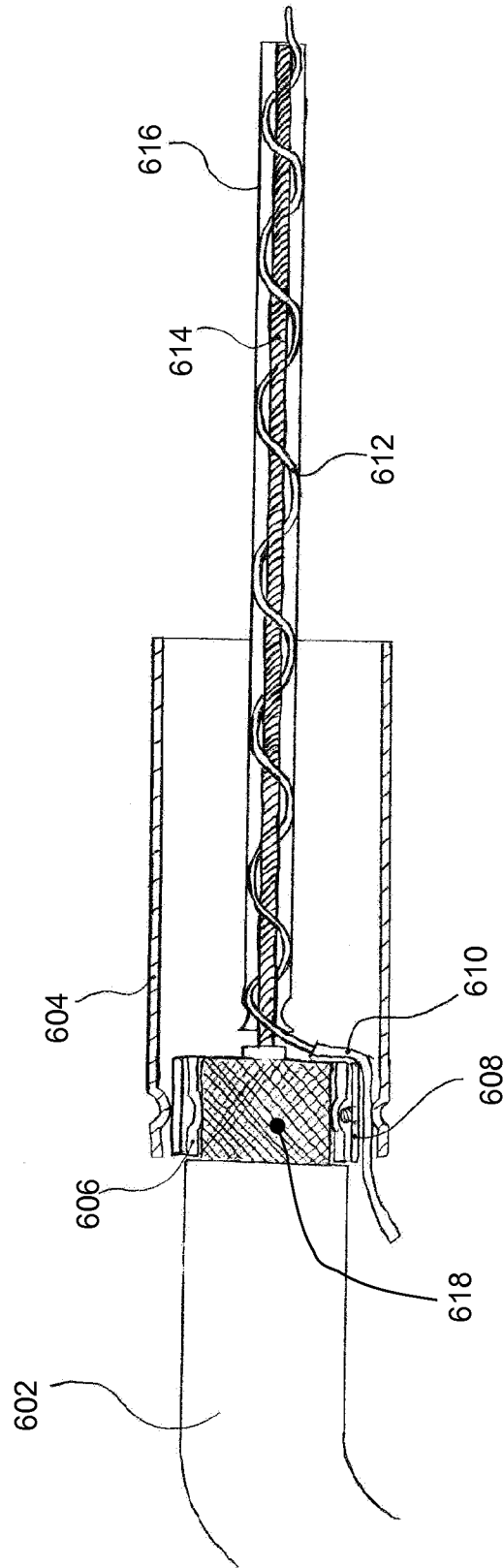

Figure 6B

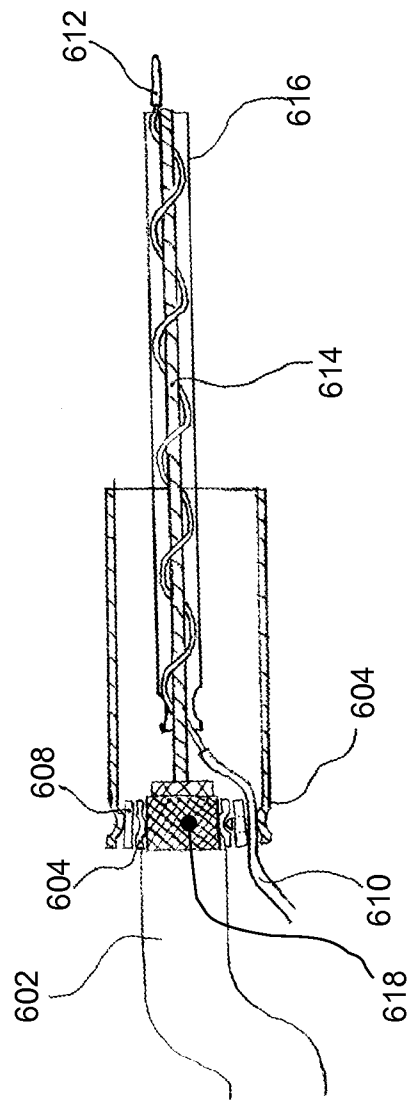

Figure 6C

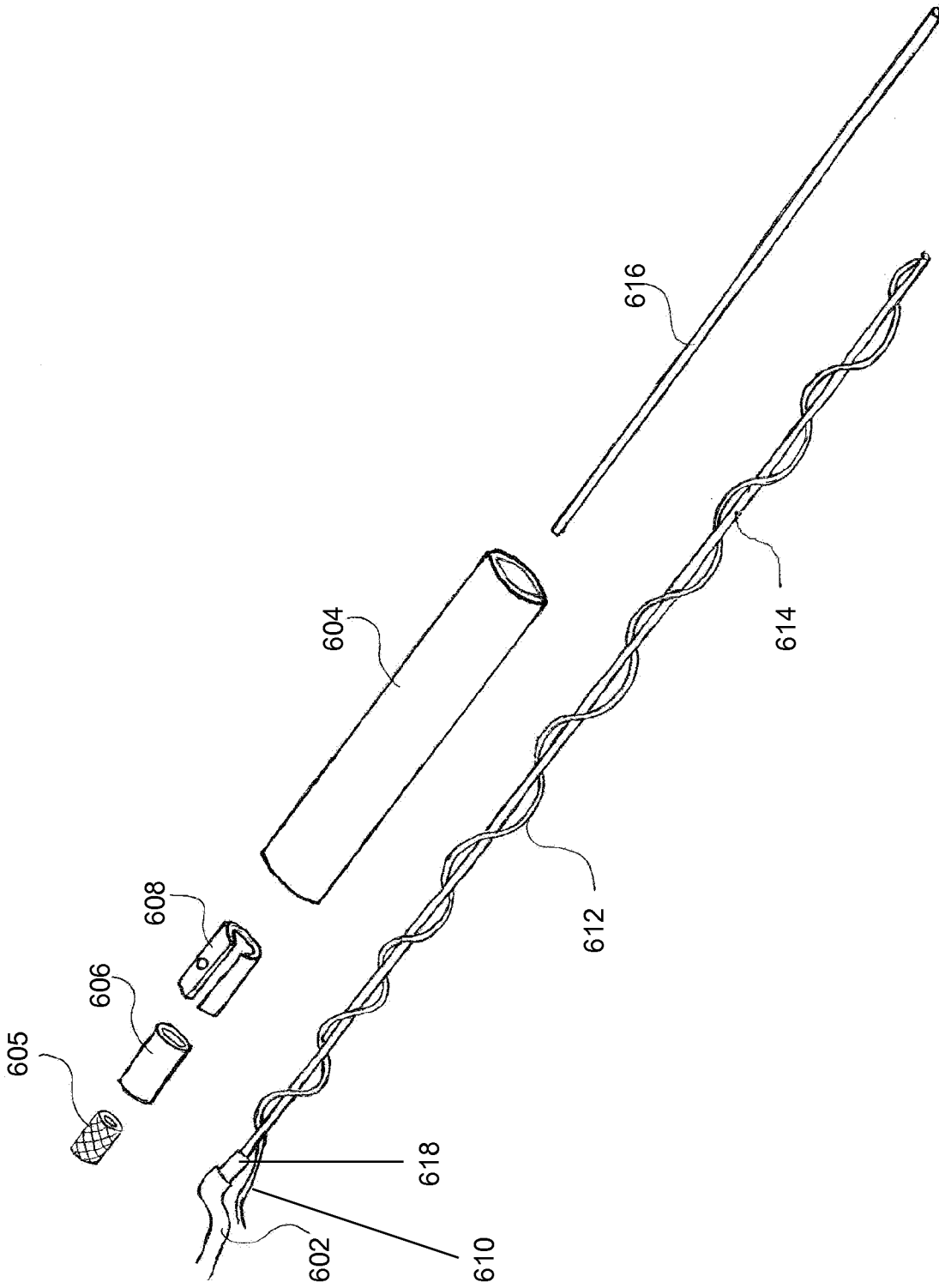

Figure 7

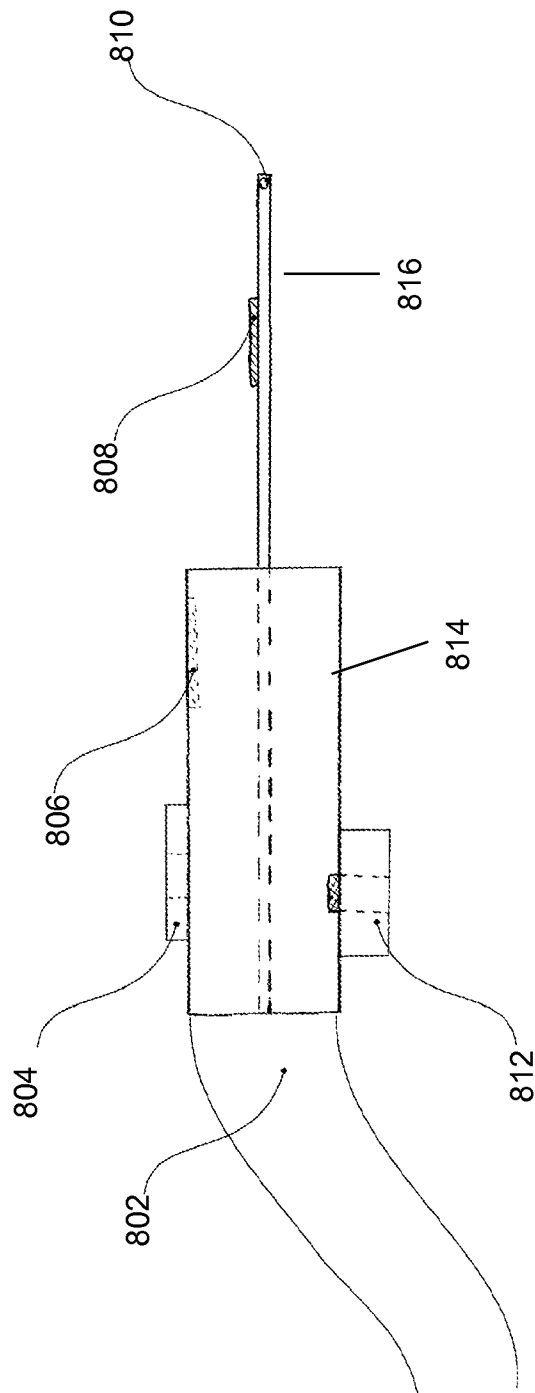

Figure 8

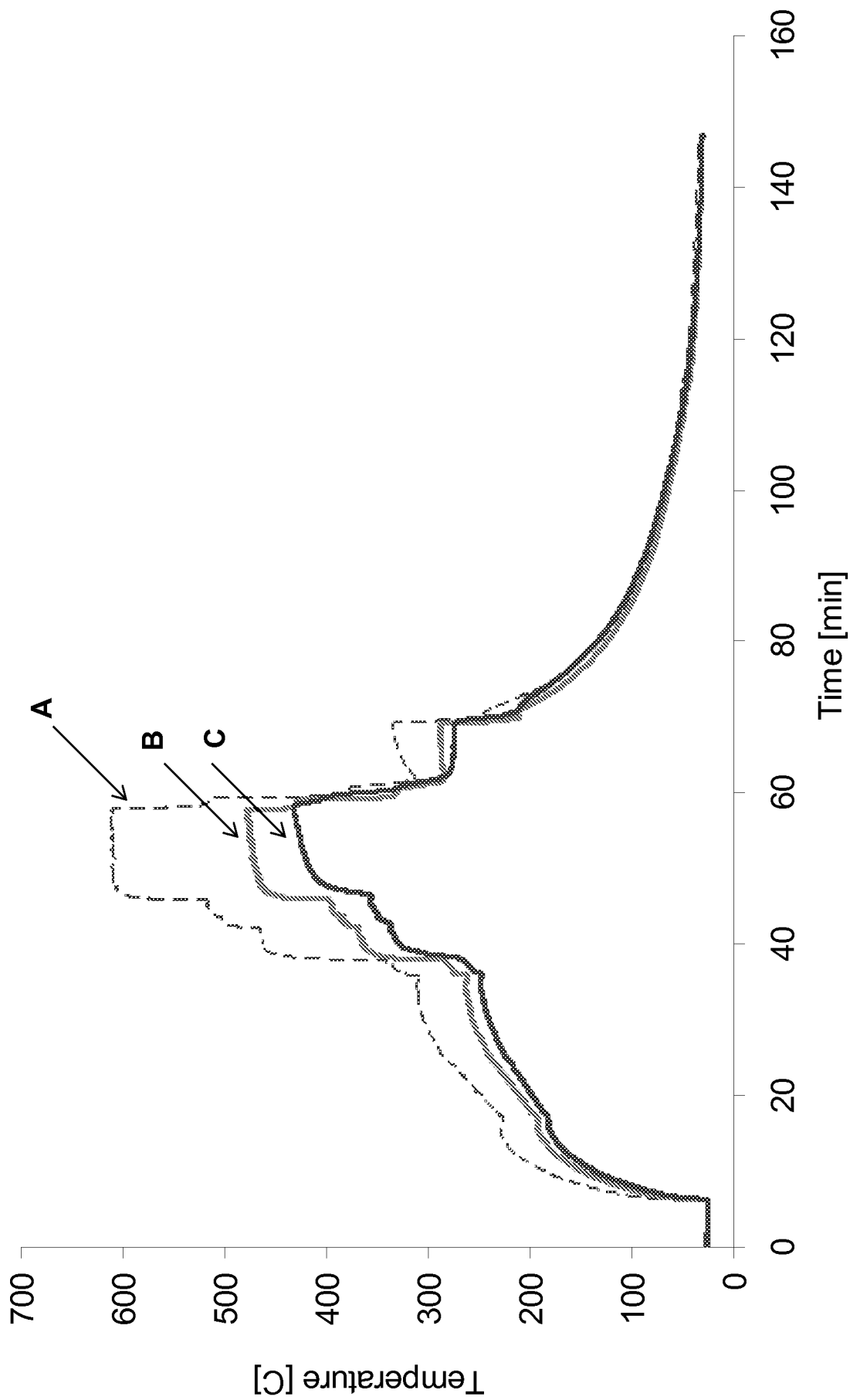

Figure 9

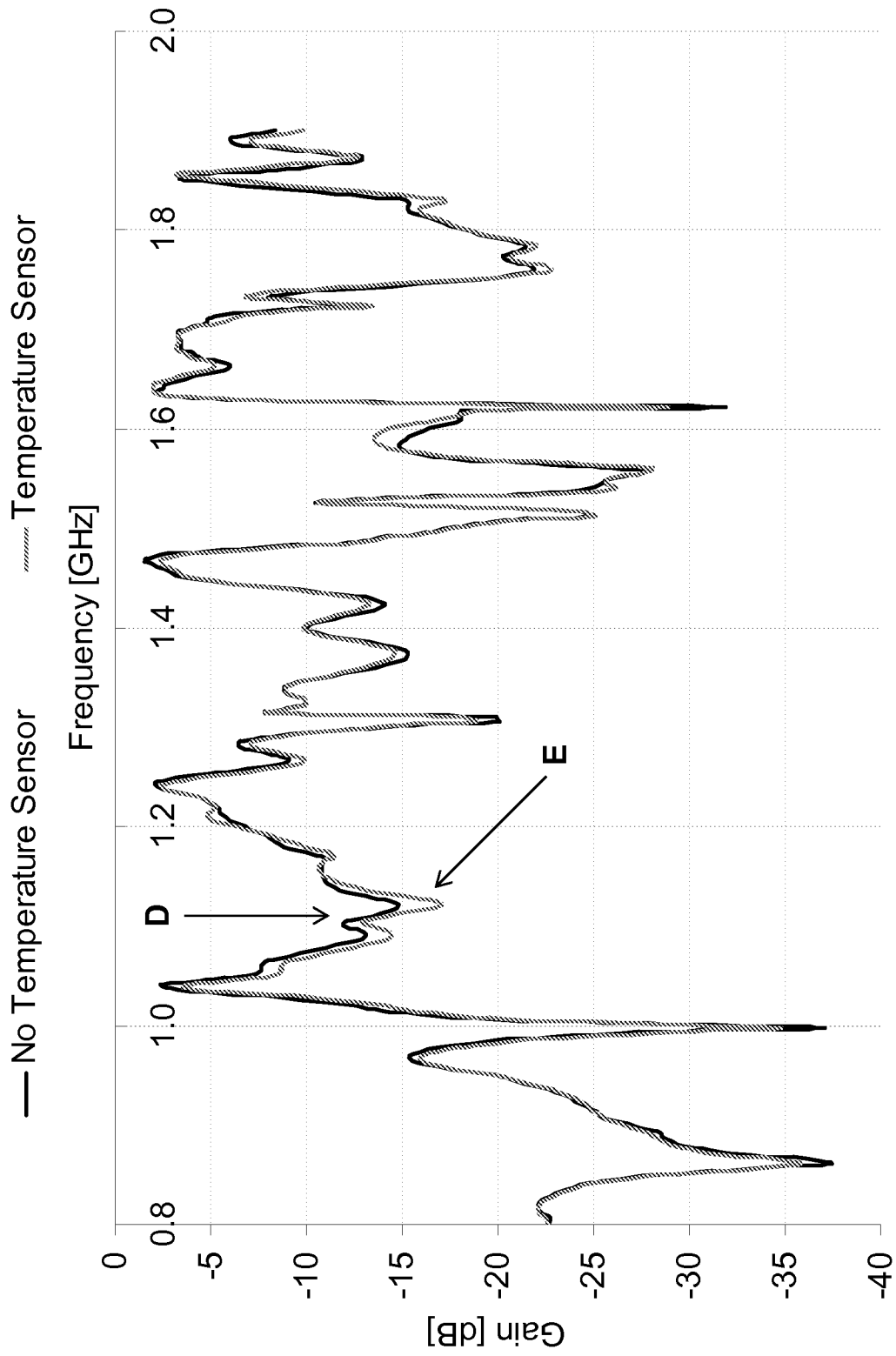

Figure 10

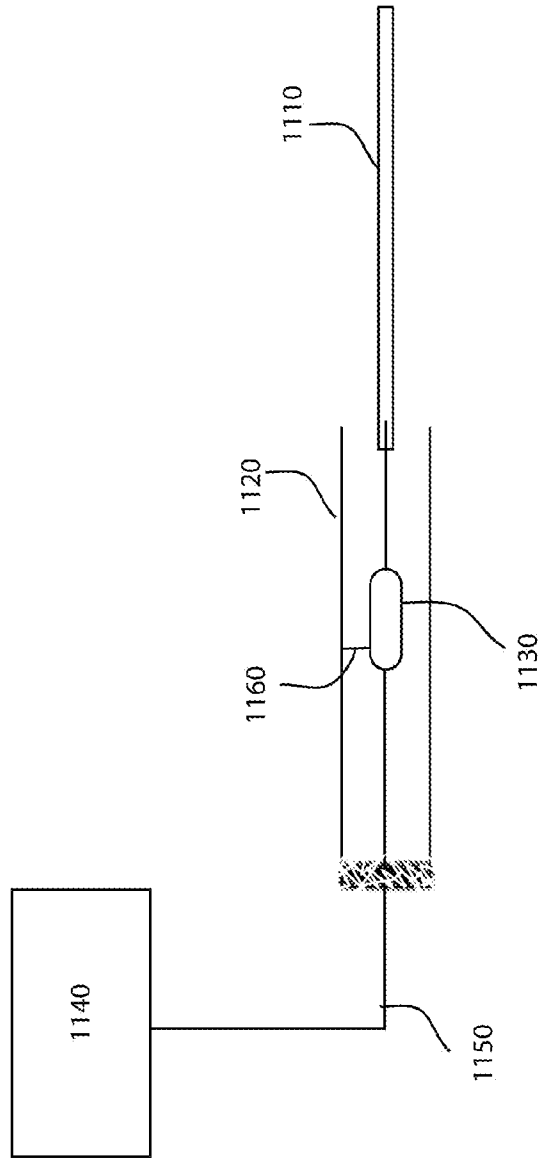

Figure 11

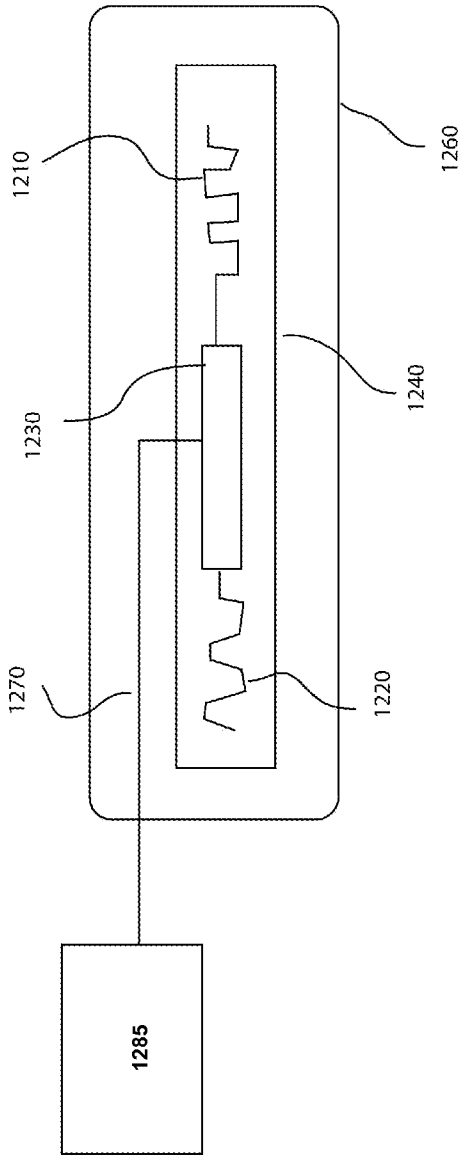

Fig. 12A Antenna assembly where the antennae and the RF electronics are placed on a board.

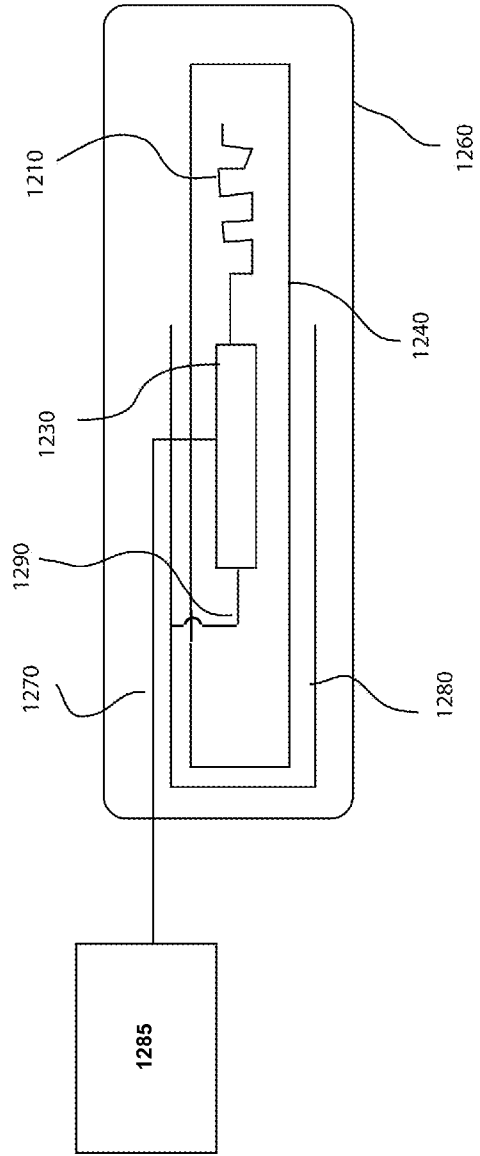

Fig 12B. Alternative antenna assembly where a hollow tube is used as second element of the antenna.

Figure 12

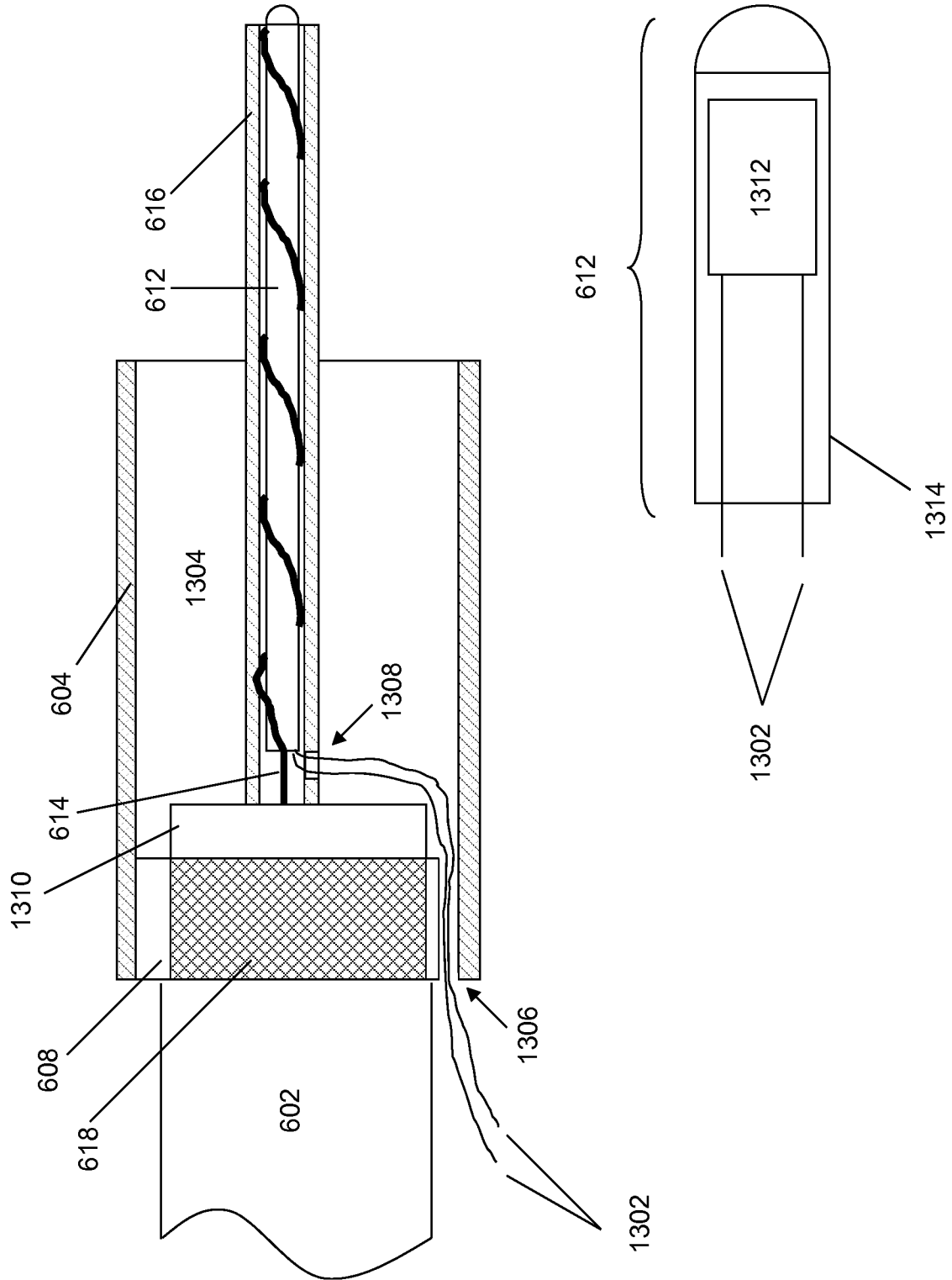

Figure 13

INTERNATIONAL SEARCH REPORT

International application No.

PCT/US2014/064475

<p>A. CLASSIFICATION OF SUBJECT MATTER                  IPC(8) - G01K 7/04 (2015.01)                  CPC - G01K 7/04 (2015.01)                  According to International Patent Classification (IPC) or to both national classification and IPC</p>																							
<p>B. FIELDS SEARCHED</p> <p>Minimum documentation searched (classification system followed by classification symbols)                  IPC(8) - A61B 18/00; G01K 7/04, 13/00; G01N 27/02; G01R 1/067, 31/02; H01J 23/00, 23/46; H01P 1/08, 1/202 (2015.01)                  CPC - A61B 18/18, 18/1815; G01K 7/04, 13/002; G01N 27/023; G01R 1/06722, 1/06788; H01J 23/005, 23/46; H01P 1/08, 1/202 (2015.01)</p> <p>Documentation searched other than minimum documentation to the extent that such documents are included in the fields searched                  USPC - 310/11; 313/20, 21, 30, 35, 36; 315/35; 324/72.5, 204, 224, 236, 446, 715, 755.02; 333/12, 206; 336/57, 179; 374/122; 607/102, 156 (keyword delimited)</p> <p>Electronic data base consulted during the international search (name of data base and, where practicable, search terms used)                  Orbit, Google Patents, Google Scholar.                  Search terms used: radio frequency probe, coaxial cable, inner conductor sheath, inner dielectric, coaxial braid, outer insulating sleeve, crimp connections, ancillary sensor, spacer ring, temperature sensor, radio frequency control unit, microwave resonant cavity.</p>																							
<p>C. DOCUMENTS CONSIDERED TO BE RELEVANT</p> <table border="1"> <thead> <tr> <th>Category*</th> <th>Citation of document, with indication, where appropriate, of the relevant passages</th> <th>Relevant to claim No.</th> </tr> </thead> <tbody> <tr> <td>X -- Y</td> <td>US 4,945,318 A (KABACHINSKI et al) 31 July 1990 (31.07.1990) entire document</td> <td>1-5 ----- 6, 9-11, 13-17</td> </tr> <tr> <td>X -- Y</td> <td>US 4,204,549 A (PAGLIONE) 27 May 1980 (27.05.1980) entire document</td> <td>18-20 ----- 6, 9-11, 13-17</td> </tr> <tr> <td>Y</td> <td>US 4,477,771 A (NAGY et al) 16 October 1984 (16.10.1984) entire document</td> <td>15, 16</td> </tr> <tr> <td>A</td> <td>US 4,841,988 A (FETTER et al) 27 June 1989 (27.06.1989) entire document</td> <td>1-20</td> </tr> <tr> <td>A</td> <td>US 7,194,383 B2 (CLARKE et al) 20 March 2007 (20.03.2007) entire document</td> <td>1-20</td> </tr> <tr> <td>A</td> <td>US 8,384,396 B2 (BROMBERG et al) 26 February 2013 (26.02.2013) entire document</td> <td>1-20</td> </tr> </tbody> </table>			Category*	Citation of document, with indication, where appropriate, of the relevant passages	Relevant to claim No.	X -- Y	US 4,945,318 A (KABACHINSKI et al) 31 July 1990 (31.07.1990) entire document	1-5 ----- 6, 9-11, 13-17	X -- Y	US 4,204,549 A (PAGLIONE) 27 May 1980 (27.05.1980) entire document	18-20 ----- 6, 9-11, 13-17	Y	US 4,477,771 A (NAGY et al) 16 October 1984 (16.10.1984) entire document	15, 16	A	US 4,841,988 A (FETTER et al) 27 June 1989 (27.06.1989) entire document	1-20	A	US 7,194,383 B2 (CLARKE et al) 20 March 2007 (20.03.2007) entire document	1-20	A	US 8,384,396 B2 (BROMBERG et al) 26 February 2013 (26.02.2013) entire document	1-20
Category*	Citation of document, with indication, where appropriate, of the relevant passages	Relevant to claim No.																					
X -- Y	US 4,945,318 A (KABACHINSKI et al) 31 July 1990 (31.07.1990) entire document	1-5 ----- 6, 9-11, 13-17																					
X -- Y	US 4,204,549 A (PAGLIONE) 27 May 1980 (27.05.1980) entire document	18-20 ----- 6, 9-11, 13-17																					
Y	US 4,477,771 A (NAGY et al) 16 October 1984 (16.10.1984) entire document	15, 16																					
A	US 4,841,988 A (FETTER et al) 27 June 1989 (27.06.1989) entire document	1-20																					
A	US 7,194,383 B2 (CLARKE et al) 20 March 2007 (20.03.2007) entire document	1-20																					
A	US 8,384,396 B2 (BROMBERG et al) 26 February 2013 (26.02.2013) entire document	1-20																					
<p><input type="checkbox"/> Further documents are listed in the continuation of Box C. <input type="checkbox"/></p>																							
<p>* Special categories of cited documents:</p> <table border="0"> <tr> <td>“A” document defining the general state of the art which is not considered to be of particular relevance</td> <td>“T” later document published after the international filing date or priority date and not in conflict with the application but cited to understand the principle or theory underlying the invention</td> </tr> <tr> <td>“E” earlier application or patent but published on or after the international filing date</td> <td>“X” document of particular relevance; the claimed invention cannot be considered novel or cannot be considered to involve an inventive step when the document is taken alone</td> </tr> <tr> <td>“L” document which may throw doubts on priority claim(s) or which is cited to establish the publication date of another citation or other special reason (as specified)</td> <td>“Y” document of particular relevance; the claimed invention cannot be considered to involve an inventive step when the document is combined with one or more other such documents, such combination being obvious to a person skilled in the art</td> </tr> <tr> <td>“O” document referring to an oral disclosure, use, exhibition or other means</td> <td>“&amp;” document member of the same patent family</td> </tr> <tr> <td>“P” document published prior to the international filing date but later than the priority date claimed</td> <td></td> </tr> </table>			“A” document defining the general state of the art which is not considered to be of particular relevance	“T” later document published after the international filing date or priority date and not in conflict with the application but cited to understand the principle or theory underlying the invention	“E” earlier application or patent but published on or after the international filing date	“X” document of particular relevance; the claimed invention cannot be considered novel or cannot be considered to involve an inventive step when the document is taken alone	“L” document which may throw doubts on priority claim(s) or which is cited to establish the publication date of another citation or other special reason (as specified)	“Y” document of particular relevance; the claimed invention cannot be considered to involve an inventive step when the document is combined with one or more other such documents, such combination being obvious to a person skilled in the art	“O” document referring to an oral disclosure, use, exhibition or other means	“&” document member of the same patent family	“P” document published prior to the international filing date but later than the priority date claimed												
“A” document defining the general state of the art which is not considered to be of particular relevance	“T” later document published after the international filing date or priority date and not in conflict with the application but cited to understand the principle or theory underlying the invention																						
“E” earlier application or patent but published on or after the international filing date	“X” document of particular relevance; the claimed invention cannot be considered novel or cannot be considered to involve an inventive step when the document is taken alone																						
“L” document which may throw doubts on priority claim(s) or which is cited to establish the publication date of another citation or other special reason (as specified)	“Y” document of particular relevance; the claimed invention cannot be considered to involve an inventive step when the document is combined with one or more other such documents, such combination being obvious to a person skilled in the art																						
“O” document referring to an oral disclosure, use, exhibition or other means	“&” document member of the same patent family																						
“P” document published prior to the international filing date but later than the priority date claimed																							
<p>Date of the actual completion of the international search 22 January 2015</p>		<p>Date of mailing of the international search report <b>12 FEB 2015</b></p>																					
<p>Name and mailing address of the ISA/US                  Mail Stop PCT, Attn: ISA/US, Commissioner for Patents                  P.O. Box 1450, Alexandria, Virginia 22313-1450                  Facsimile No. 571-273-3201</p>		<p>Authorized officer:                  Blaine R. Copenheaver                  PCT Helpdesk: 571-272-4300                  PCT OSP: 571-272-7774</p>																					