



(22) Date de dépôt/Filing Date: 2000/04/07
(41) Mise à la disp. pub./Open to Public Insp.: 2001/10/07

(51) Cl.Int.⁷/Int.Cl.⁷ B62D 63/08, B60P 9/00, B62D 53/00

(71) Demandeur/Applicant:
MCCOY BROS. INC., CA

(72) Inventeur/Inventor:
KAPICKI, ERNEST KEN, CA

(74) Agent: THOMPSON LAMBERT

(54) Titre : DISPOSITIF POUR HAUSSER UN ESSIEU
(54) Title: AXLE BOOSTER

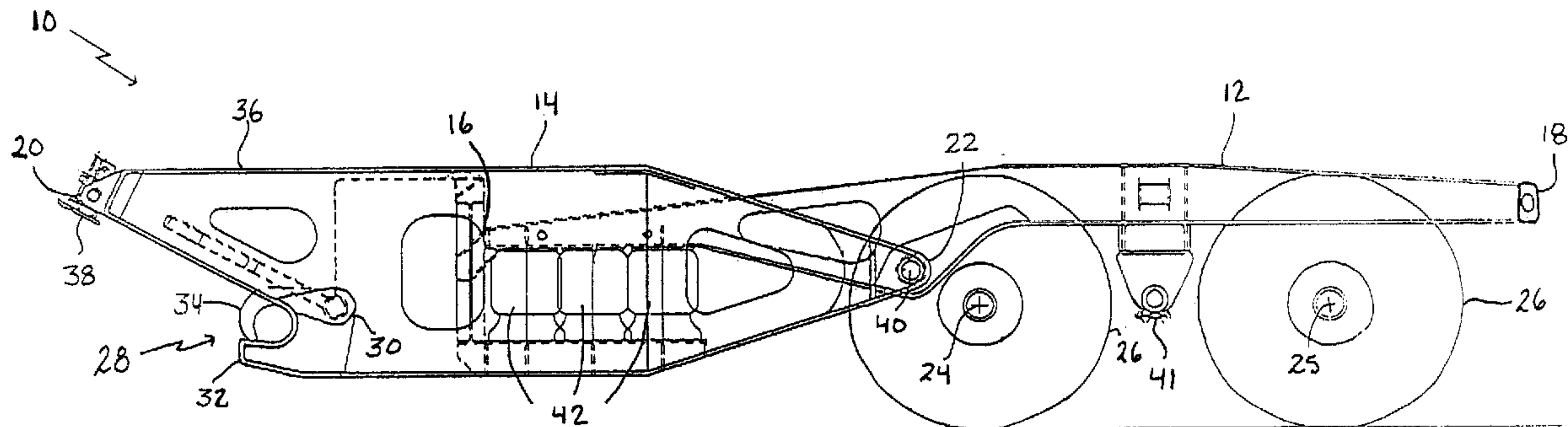

(57) Abrégé/Abstract:

An axle booster having a first frame and a second frame. At least one axle is secured toward a rear end of the first frame. A trailer coupling is positioned at the front end of the second frame. The rear end of the second frame is pivotally connected to the first frame by a pivotal connection. The pivotal connection is spaced forward of the axle of the first frame, with the front end of the first frame overlying the second frame. A plurality of air bags are positioned between the second frame and the front end of the first frame to exert a lifting force.

ABSTRACT OF THE DISCLOSURE

An axle booster having a first frame and a second frame. At least one axle is secured toward a rear end of the first frame. A trailer coupling is positioned at the front end of
5 the second frame. The rear end of the second frame is pivotally connected to the first frame by a pivotal connection. The pivotal connection is spaced forward of the axle of the first frame, with the front end of the first frame overlying the second frame. A plurality of air bags are positioned
10 between the second frame and the front end of the first frame to exert a lifting force.

TITLE OF THE INVENTION:

Axle Booster

FIELD OF THE INVENTION

5 The present invention relates to an axle booster used by trailers that carry indivisible heavy loads.

BACKGROUND OF THE INVENTION

10 There are laws relating to the weight of loads that can be carried on our highways. These load laws are expressed in terms of load upon each axle group. Most heavy loads are capable of being divided into smaller loads in order to comply with these laws. However, some loads are unitary structures that are indivisible. In order to comply with load laws when
15 hauling indivisible heavy loads additional axles groups must be added. These additional axle groups are commonly known as "axle boosters".

20 The theory behind an axle booster, is that an indivisible heavy load can be carried within the limits set by the load laws, if the load can be spread over sufficient additional axle groups. The axle booster consists of a first frame and a second frame. The first frame has a front end and a rear end. At least one axle, preferably two axles, is secured toward the
25 rear end of the first frame. The second frame has a front end and a rear end. A coupling is positioned at the front end of the second frame, which is used to attach the axle booster to a trailer bearing the indivisible heavy load. The second frame is pivotally connected to the first frame by a pivotal
30 connection. The pivotal connection is positioned adjacent to the coupling of the second frame and at the front end of the first frame, with the rear end of the second frame overlying the front end of the first frame. The pivotal connection serves as a fulcrum and the rear end of the second frame serves
35 as a lever. A selective distribution of load from the trailer

to the axle booster is effected by exerting a lifting force upon the rear end of the second frame. This serves to lift the end of the trailer and transfer a portion of the weight onto the axle booster. A plurality of air bags are positioned
5 between the first frame and the rear end of the second frame to exert the lift required to the transfer of weight.

Axle boosters, as described above, operated for a number of years when manual valves were used to inflate the air bags. Problems are occurring, however, now that the industry has
10 started to shift to automatic inflation through height control valves running from the trailer unit. Automatic height control valves vary the inflation pressure in the air bags to maintain the trailer deck at a preset height. The trailer deck is at
15 a constant height whether loaded or unloaded. As load is added to the trailer, the automatic height control valves increase the air pressure to the air bags. When the axle booster is connected to the automatic height control system of the trailer, the air bags of the axle booster receive the same air
20 pressure as the air bags of the trailer. Current axle booster configurations are not working properly with the automatic height controls due to mechanical inefficiencies inherent in the design the axle boosters. The automatic systems are incapable of transferring sufficient weight to the axle
25 boosters. In order to compensate additional air bags are being added, but this is not completely solving the problem. Shimming is also being used, but this also is not completely solving the problem either. As a result, the vast majority of trailers with axle boosters operating with automatic height
30 controls for air bag inflation are not in compliance with load laws.

SUMMARY OF THE INVENTION

What is required is a configuration of axle booster that
35 is compatible with automatic height control systems for air bag inflation.

According to the present invention there is provided an axle booster consists of a first frame and a second frame. The first frame has a front end and a rear end. At least one axle is secured toward the rear end of the first frame whereby support wheels are rotatably mounted to the first frame. The second frame has a front end and a rear end. A coupling is positioned at the front end of the second frame, whereby the second frame is attached to a trailer. The rear end of the second frame is pivotally connected to the first frame by a pivotal connection. The pivotal connection is spaced forward of the least one axle of the first frame, with the front end of the first frame overlying the second frame. A plurality of air bags are positioned between the second frame and the front end of the first frame. Upon inflation of the air bags a lifting force is exerted upon a rear of the trailer to selectively transfer weight from the trailer to the at least one axle of the first frame.

The axle booster, as described above, has proven to be more readily adaptable for use with automated air bag inflation systems incorporated into the trailer's automatic inflation height control. Of course, the axle booster can also be used with manual air bag inflation controls as is necessary for use with a trailer that is not equipped with an air suspension system. Improved mechanical advantage has been obtained by changing the relative positioning of the first frame and the second frame, changing the position of the pivotal connection and changing the position of the air bags, as will hereinafter be further described.

30

BRIEF DESCRIPTION OF THE DRAWINGS

These and other features of the invention will become more apparent from the following description in which reference is made to the appended drawings, the drawings are for the purpose of illustration only and are not intended to in any way limit the scope of the invention to the particular embodiment or

35

embodiments shown, wherein:

FIGURE 1 is a side elevation view of an axle booster constructed in accordance with the teachings of the present invention, with air bags in an intermediate position.

5 **FIGURE 2** is a side elevation view of the axle booster illustrated in **FIGURE 1**, with air bags substantially deflated.

FIGURE 3 is a side elevation view of the axle booster illustrated in **FIGURE 1**, with air bags substantially inflated with a trailer not bearing a load.

10 **FIGURE 4** is a side elevation view of the axle booster illustrated in **FIGURE 1**, with air bags substantially inflated with a trailer bearing a load.

FIGURE 5 is a top plan view of the axle booster illustrated in **FIGURE 1**.

15

DETAILED DESCRIPTION OF THE PREFERRED EMBODIMENT

The preferred embodiment, an axle booster generally identified by reference numeral 10, will now be described with reference to **FIGURES 1** through **5**.

20

Structure and Relationship of Parts:

Referring to **FIGURE 1**, axle booster 10 consists of a first frame 12 and a second frame 14. First frame 12 has a front end 16 and a rear end 18. Second frame 14 has a front end 20 and
25 a rear end 22. A pair of axles 24 and 25 are secured transversely in parallel spaced relation to rear end 18 of first frame 12. Axles 24 and 25 support rotatably mounted wheels 26. A coupling, generally indicated by reference numeral 28 is positioned at front end 20 of second frame 14.
30 Coupling 28 is used to attached second frame 14 to a trailer. Coupling 28 is known in the art and does not form part of the present invention. The particular form of coupling 28 will vary with the style of trailer. The form of coupling 28 chosen for the purpose of illustration has a locking jaw 30 with a fixed
35 jaw member 32 and a second jaw member 34. Coupling 28 also has an extending weight transfer arm 36 terminating in a pressure member 38. Rear end 22 of second frame 14 is pivotally

connected to first frame 12 by a pivotal connection identified by reference numeral 40. Pivotal connection 40 is spaced from axle 24 of first frame 12. It is to be noted that in marked contrast to the prior art front end 16 of first frame 12
5 overlies second frame 14. Referring to **FIGURE 1**, a plurality of air bags 42 are positioned between second frame 14 and front end 16 of first frame 12. Upon inflation of air bags 42 a lifting force is exerted, which is used to selectively transfer weight from a trailer to axle booster 10 as will hereinafter
10 be further described in relation to operation.

Operation:

The use and operation of axle booster 10 will now be
15 described with reference to **FIGURES 1** through **5**. Coupling 28 of axle booster 10, as illustrated in **FIGURE 1**, is intended to be used with a style of trailer commonly used to transport construction vehicles. Referring to **FIGURE 2**, there is
illustrated a rear portion 102 of a trailer 100. Rear portion
20 102 of trailer 100 has a transverse coupling bar 104 and a sloped loading ramp 106. When an indivisible load is to be carried upon trailer 100, axle booster 10 is coupled to trailer 100 with air bags 42 in a deflated condition. In order to do this locking jaw 30 is attached to transverse coupling bar 104.
25 Pressure member 38 of weight transfer arm 36 bears against sloped loading ramp 106. Referring to **FIGURES 3** and **4**, air bags 42 are then inflated. The inflation of air bags 42 can be performed through a manually activated valve or through an air coupling to an automated height adjustment system for
30 trailer 100. Referring to **FIGURE 3** and **4**, an air conduit 108 is shown as extending from trailer 100. Air conduit 108 links axle booster 10 to an automated height adjustment system of trailer 100. As air bags 42 inflate, locking jaw 30 exerts an upward force upon transverse coupling bar 104 and pressure
35 member 38 bears against sloped loading ramp 106. As can be seen from a comparison of **FIGURES 2, 3** and **4**, as air bags 42 continue to inflate rear portion 102 of trailer 100 is

physically lifted. When trailer 100 is not bearing a load, rear portion 102 is lift right off the ground, as is illustrated in **FIGURE 3**. Referring to **FIGURE 4**, when trailer 100 is bearing a load, rear portion 102 is lifted sufficiently to raise the height of the trailer deck and shift a portion of the rear load to axles 24 and 25 of axle booster 10. It is to be noted that the lifting action results in some pivotal movement of first frame 12 at trunnion 41. It also results in a portion of the weight being transferred from rear portion 102 of trailer 100 toward the front, as will hereinafter be further explained.

Cautionary Warnings:

Care must be taken in positioning pivotal connection 40 along first frame 12. On a dual axle trailer, if pivotal connection 40 were positioned to provide the maximum mechanical advantage, pivotal connection 40 would be positioned at trunnion 41. However, this positioning is not practical due to the limited travel in air bags 42. Each of air bags 42 has a limited working range. Although air bags 42 are capable of travel beyond their working range, they are only capable of providing a lifting force within their working range. The precise positioning of pivotal connection 40 is, therefore, a compromise intended to obtain the maximum mechanical advantage within the working range of air bags 42. The flexing of trailer 100 must be taken into account. Air bags 42 will need to inflate axle booster 10 sufficiently to accommodate flexing by trailer 100 before any actual lift can provided by axle booster 10 to trailer 100. When axle booster 10 is first attached to trailer 100, air bags 42 receive the same air pressure as the air bags of trailer 100. This results in an initial lift of rear portion 102 of trailer 100. If trailer 100 were without load, the lift would be enough to lift rear portion 102 of trailer 100 right off the ground. When trailer 100 is under heavy load, rear portion 102 is raised sufficiently to alter the height of the trailer deck. In response to the raising of the height of the trailer deck, the

automatic height control will make an adjustment to reduce air pressure to all air bags to maintain the height of the trailer deck at the preset height. While the addition of the axle booster has the effect of taking some of the weight off the rear axles of trailer 100, the lifting of rear portion 102 of trailer 100 also has the effect of shifting a portion of the weight toward the front. In view of this shift of weight toward the front, in order to achieve maximum loading it is necessary to position the load rearward on trailer 100 when axle booster 10 is to be added. The best positioning for the load on trailer 100 without axle booster 10 will differ from the best positioning of the load on trailer 100 with axle booster 10.

15 In this patent document, the word "comprising" is used in its non-limiting sense to mean that items following the word are included, but items not specifically mentioned are not excluded. A reference to an element by the indefinite article "a" does not exclude the possibility that more than one of the element is present, unless the context clearly requires that there be one and only one of the elements. It will be apparent to one skilled in the art that modifications may be made to the illustrated embodiment without departing from the spirit and scope of the invention as hereinafter defined in the Claims.

25

THE EMBODIMENTS OF THE INVENTION IN WHICH AN EXCLUSIVE PROPERTY OR PRIVILEGE IS CLAIMED ARE DEFINED AS FOLLOWS:

- 5 1. An axle booster, comprising:
a first frame having a front end and a rear end;
at least one axle secured toward the rear end of the first
frame whereby support wheels are rotatably mounted to the first
frame;
- 10 a second frame having a front end and a rear end;
a coupling positioned at the front end of the second
frame, whereby the second frame is attached to a trailer;
the rear end of the second frame being pivotally connected
to the first frame by a pivotal connection spaced forward of
15 the at least one axle of the first frame, with the front end
of the first frame overlying the second frame; and
a plurality of air bags positioned between the second
frame and the front end of the first frame such that upon
inflation of the air bags a lifting force is exerted upon a
20 rear of the trailer to selectively transfer weight from the
trailer to the at least one axle.

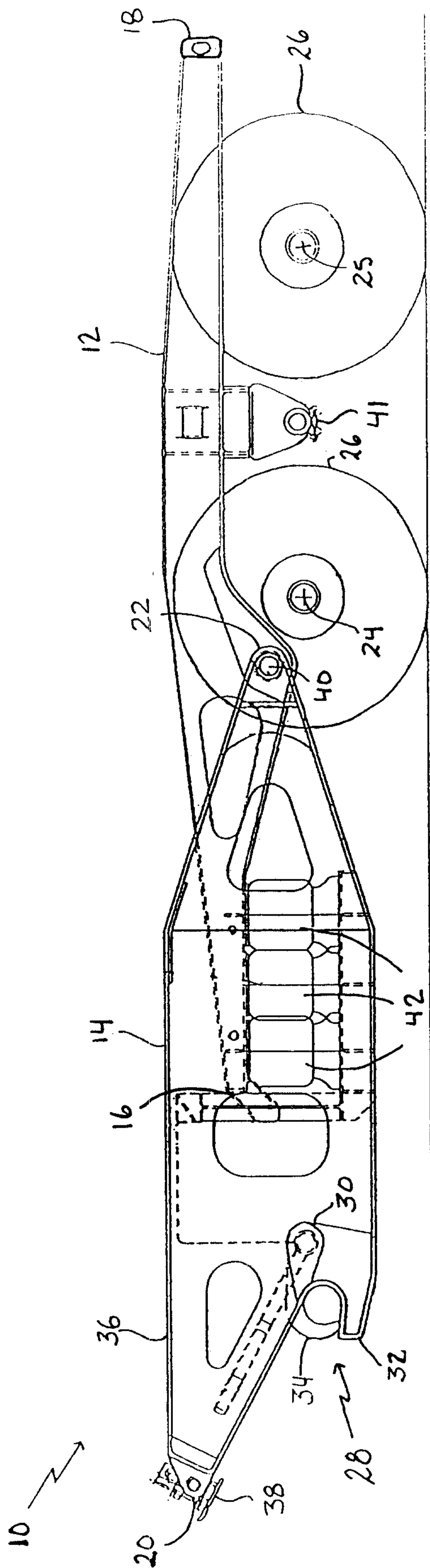

FIGURE 1

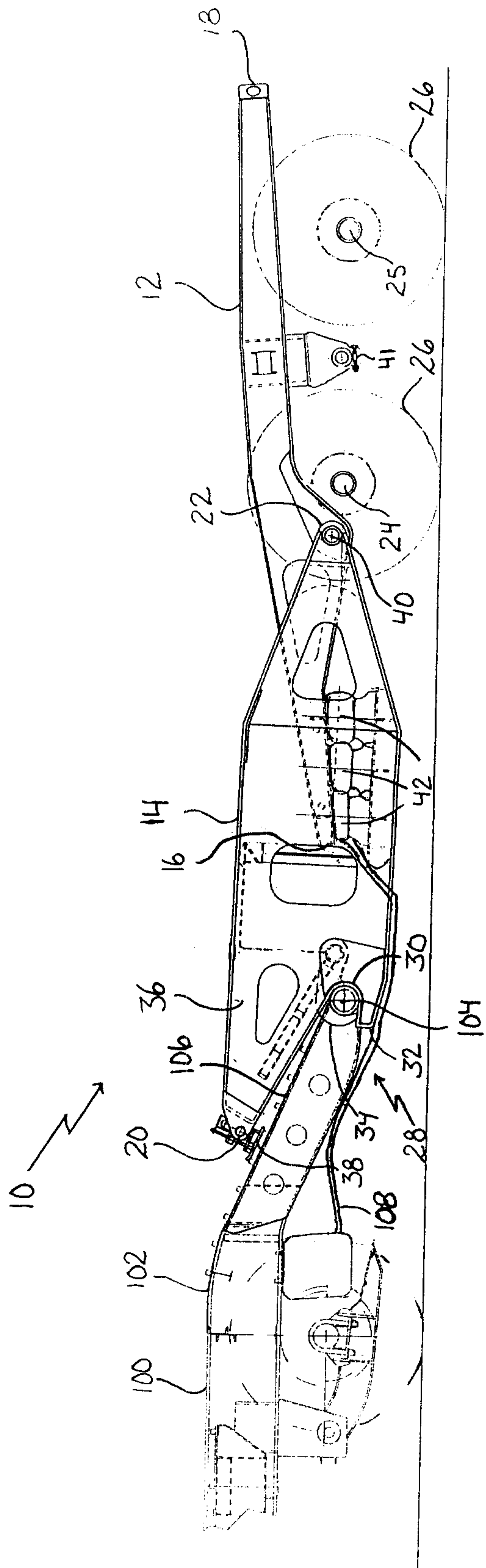

FIGURE 2

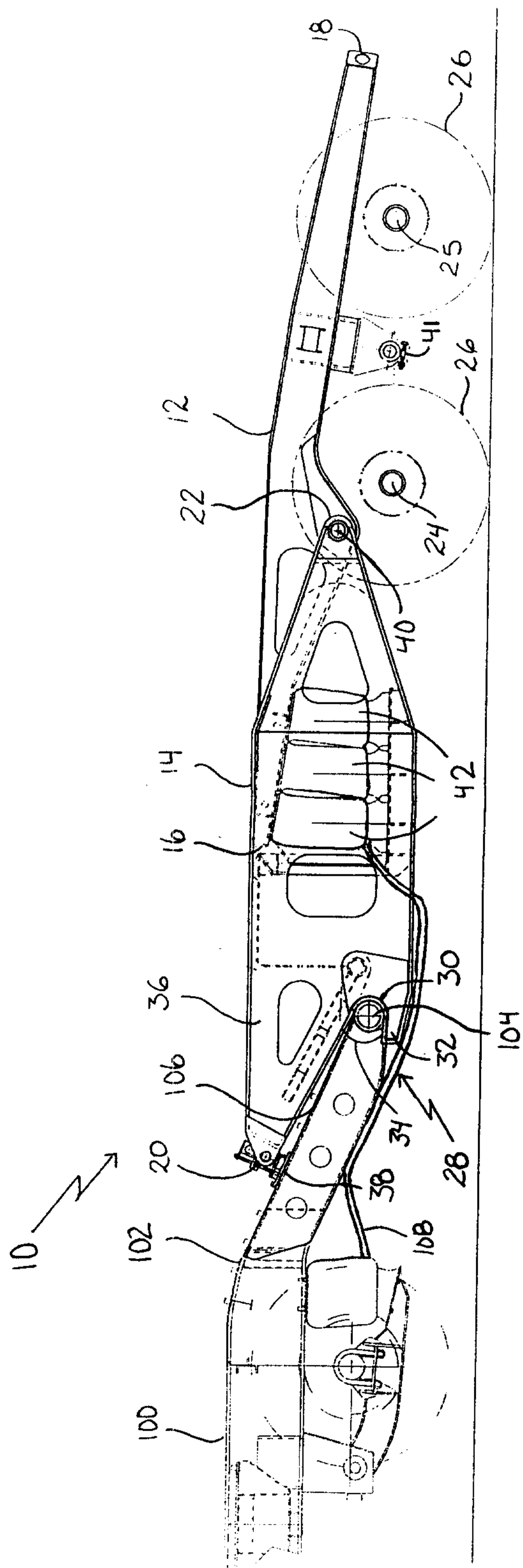

FIGURE 3

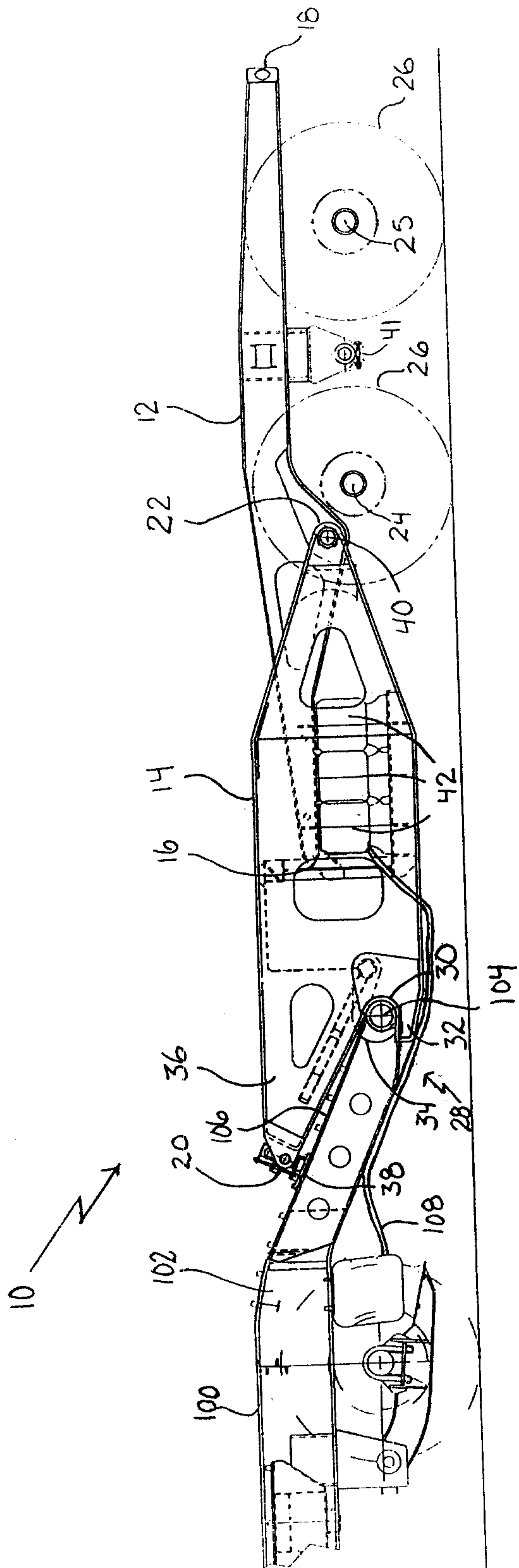

FIGURE 4

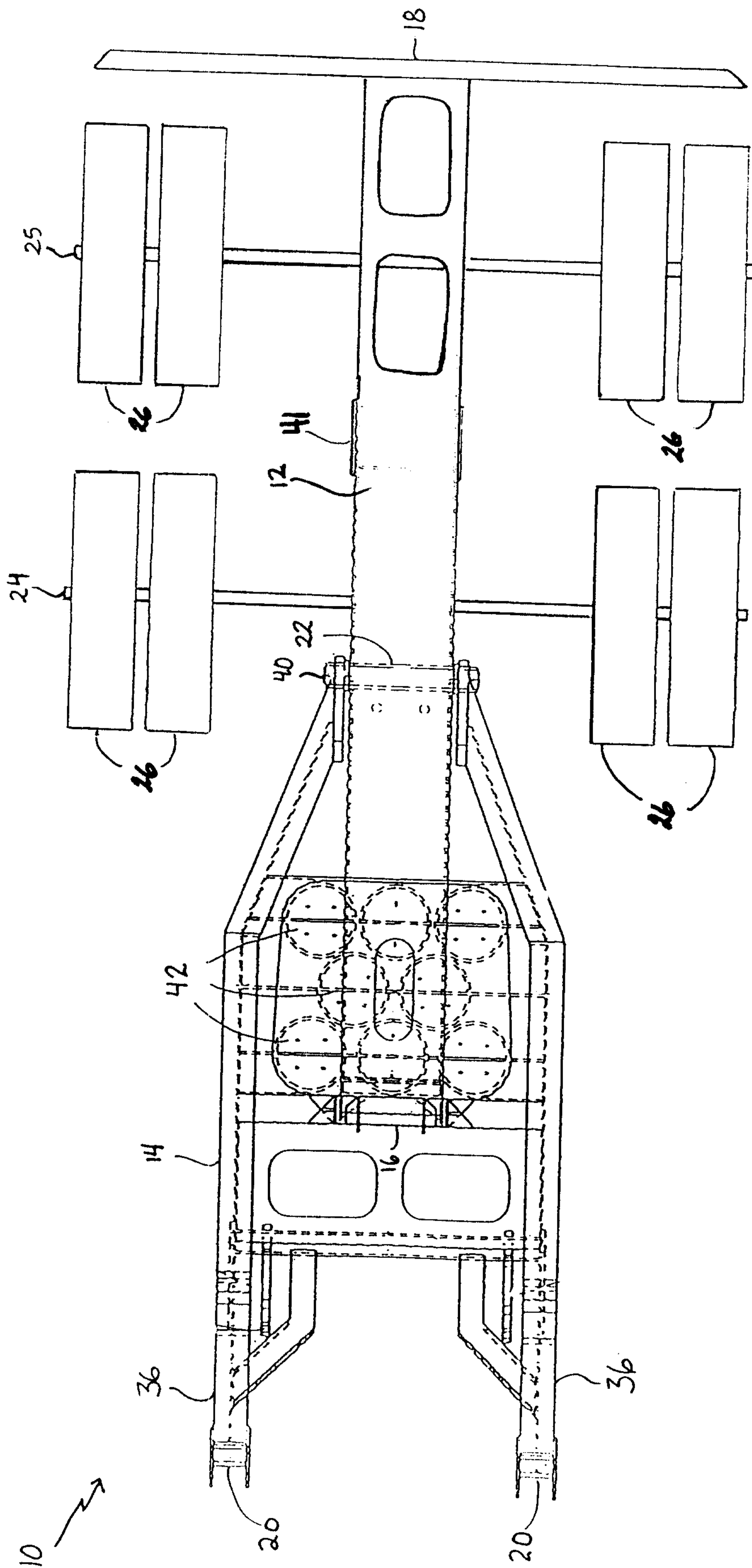

FIGURE 5

