

No. 747,942.

PATENTED DEC. 29, 1903.

B. COLOM Y MARCA.
PIPE CUTTER.

APPLICATION FILED MAY 6, 1903.

NO MODEL.

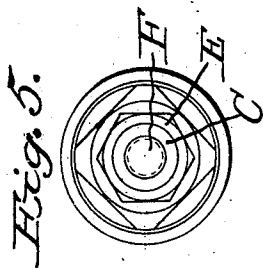

Fig. 5.

Fig. 6.

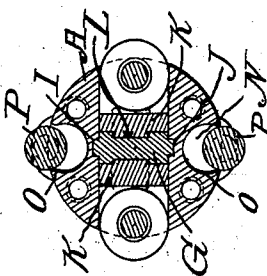

Fig. 7.

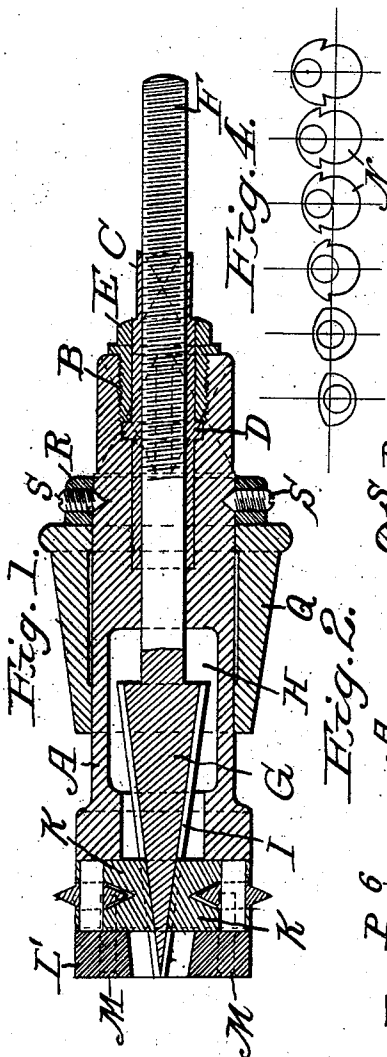
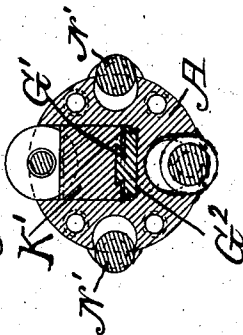

Fig. 1.

Fig. 4.

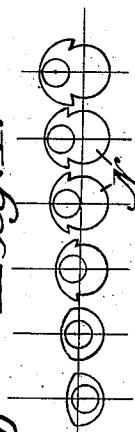

Fig. 2.

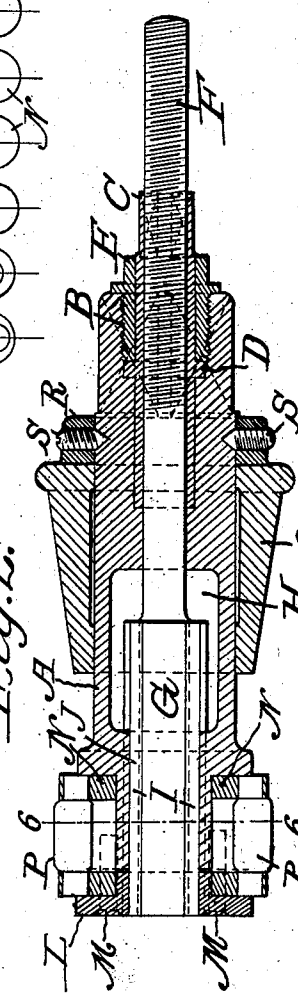
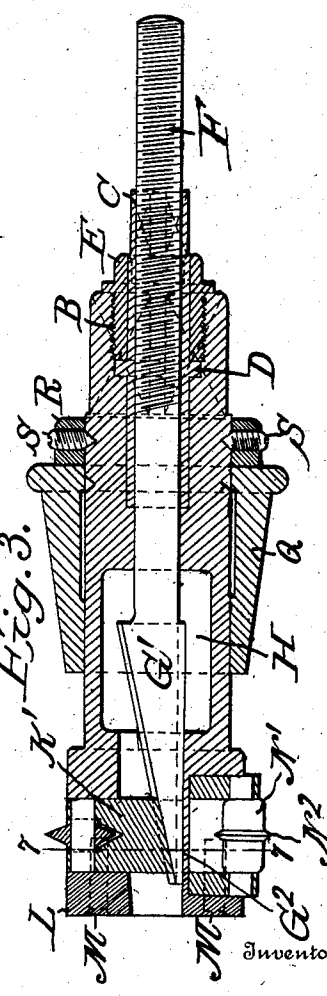

Fig. 3.



Inventor

Witnesses
C. H. Walker
H. C. Boyce

Buena Ventura Colom y Marca
By Frank A. Applemann
Attorney

UNITED STATES PATENT OFFICE.

BUENAVENTURA COLOM Y MARCA, OF BARCELONA, SPAIN.

PIPE-CUTTER.

SPECIFICATION forming part of Letters Patent No. 747,942, dated December 29, 1903.

Application filed May 6, 1903. Serial No. 155,795. (No model.)

To all whom it may concern:

Be it known that I, BUENAVENTURA COLOM Y MARCA, a subject of the King of Spain, and a resident of Barcelona, in the Province of Barcelona and Kingdom of Spain, have invented certain new and useful Improvements in Pipe-Cutters, of which the following is a specification.

This invention relates to pipe-cutters, and particularly to those designed for use in cutting boiler-tubes and the like, where the action on the tube is from the interior.

The objects of the invention are, first, to produce a cutter and, in combination therewith, means for forcing the cutter into contact with the material operated upon and in the provision of steadying-rollers and novel means for mounting the rollers according to the diameter of the work operated upon; second, to produce a cutter-head, cutters operating therein, and, in combination therewith, steadying-rollers and novel means for mounting the steadying-rollers with relation to the work operated upon, and means for securing the bearings of the steadying-rollers in the head; third, to produce a pipe-cutter in which the cutting members are moved with relation to the work operated upon and means for rotating the head and rollers.

A further object of the invention is to produce a pipe-cutter in which the position of the cut may be determined by the adjustment of a gage with relation to the cutters, the said gage abutting the end of the tube to be operated upon.

Further, an object of the invention is to produce a pipe-cutter which is applicable to varying diameters within predetermined bounds, the said cutters and guiding-rolls being in such relation as to permit the guide-rolls to act before bringing the cutters into operation.

Finally, an object of the invention is to produce a pipe-cutter which will possess advantages in points of utility, efficiency, and durability, proving at the same time satisfactory in use and comparatively inexpensive to manufacture.

With the foregoing and other objects in view the invention consists in the details of construction and in the arrangement and combination of parts to be hereinafter more fully set forth and claimed.

In describing the invention in detail reference will be had to the accompanying drawings, forming part of this specification, wherein like characters denote corresponding parts in the several views, and in which—

Figure 1 is a longitudinal vertical sectional view of the cutter. Fig. 2 is a similar view taken at right angles to the section of Fig. 1. Fig. 3 is a longitudinal vertical section of a slightly-modified construction to that shown in Fig. 1. Fig. 4 is a view in elevation of a series of bearing-blocks of graded sizes. Fig. 5 is an end view of the device. Fig. 6 is a sectional view taken on the line 6 6 of Fig. 2. Fig. 7 is a sectional view taken on the line 7 7 of Fig. 3.

In the drawings, A denotes the head of the cutter, having its rear end internally threaded at B for a portion of the distance, the said head having a way therein in which a sleeve C is seated, the said sleeve having an annular shoulder D, which is seated against a shoulder in the head. Ring-nut E is threaded in the end of the head and has its end bearing against the shoulder of the sleeve C, thereby retaining said sleeve in the head. The sleeve C is internally threaded, and the shank F, which is threaded to engage the threads of the sleeve, extends through a portion of the head and terminates in a wedge-shaped head G, the said wedge traveling in a chamber H, formed in the head. The sides of the wedge have ribs I, which travel in grooves J, formed longitudinally of the head, whereby the said wedge is guided. Blocks K are slidable in the head and have dovetailed connections L with the wedge, whereby as the wedge is moved longitudinally of the head the blocks are reciprocated. The blocks are held in place and are guided by the end of the head and the face-plate L', which is attached to the head by means of the screws M.

The bearing-blocks N are slidable in recesses O, formed in the end of the head and in recesses of the face-plate M, and the steadying-rolls P are mounted in the bearing-blocks, and from an inspection of Fig. 4, where a series of these blocks are shown, it will be observed that the distance apart of the said rolls may be regulated according to the size of the bearing-blocks employed.

The gage Q is adjustable on the head and

is moved in relation to the cutters in order to determine the position of the cutters within a tube or pipe. The collar R is held on the head by the screws S and limits the rearward movements of the gage. The head may have a series of recesses for the points of the screws, there being two such recesses, shown side by side in Fig. 3, though they may be multiplied according to requirement.

10 In the modification shown in Fig. 3 the parts are all duplicates of the parts heretofore described, except that in this modification the wedge G' has one beveled face, which acts in conjunction with a single bearing-block K', while the opposite face of the wedge rides on the wall G² of the cutter-head. The wedge is dovetailed in the cutter-head and the bearing-block K' is dovetailed on the wedge. In this construction the bearing-blocks N are the same as those employed in the double cutter; but I prefer to use the guide-roll N' with a rib N² thereon, which will follow in the cut made by the cutting-wheel, and thereby act as a guide and steadying-roll.

25 Having fully described the invention, what I claim as new, and desire to secure by Letters Patent, is—

1. In a pipe-cutter, a head having peripheral

recesses adapted to receive a series of sets of differential bearings for guide-wheels, means for retaining the bearings in position, blocks slidable in the heads, cutter-wheels journaled in the blocks.

2. In a pipe-cutter, a head having recesses adapted to receive sets of differential bearings, blocks slidable in the heads, cutter-wheels carried by the sliding blocks, guide-wheels carried by the differential bearings, a face-plate having recesses to receive the differential bearings and means for securing the face-plate to the head.

3. In a pipe-cutter, a head having recesses adapted to receive series of differential bearings, a wedge having a shank threaded to move longitudinally of the head, blocks slidable transversely of the head, means on the head for engaging the blocks, guide-rolls journaled in the bearings and a gage adjustable on the head.

In testimony whereof I affix my signature in the presence of two witnesses.

BUENAVENTURA COLOM Y MARCA.

Witnesses:

H. M. DANNEEL,
JOHN ALSINA.