

(Model.)

2 Sheets—Sheet 1.

J. KAISER.

ECCENTRIC SHIFTING MECHANISM.

No. 352,995.

Patented Nov. 23, 1886.

FIG. I.

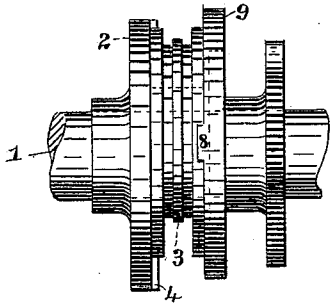

FIG. II.

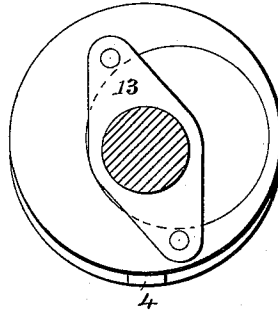

FIG. VII.

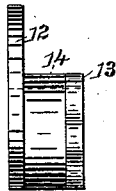

FIG. III.

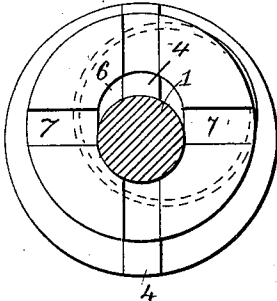

FIG. IV.

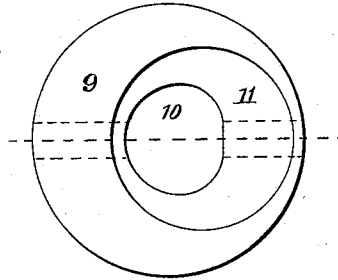
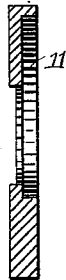

FIG. V.

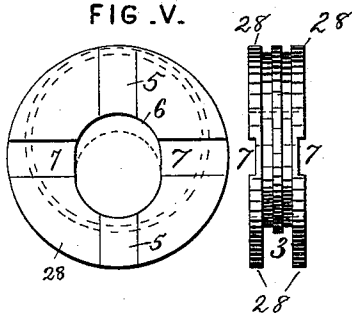
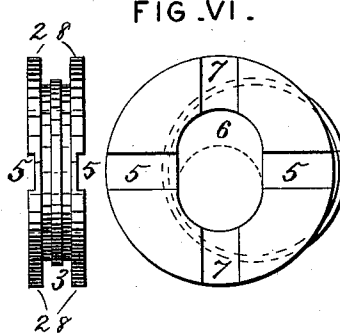

FIG. VI.



WITNESSES.

F. A. Napping.
Geo. Wheelock.

INVENTOR.

Jacob Kaiser
 134 *Knight Bros.*
 ATTORNEYS

(Model.)

2 Sheets—Sheet 2.

J. KAISER.

ECCENTRIC SHIFTING MECHANISM.

No. 352,995.

Patented Nov. 23, 1886.

FIG. VIII.

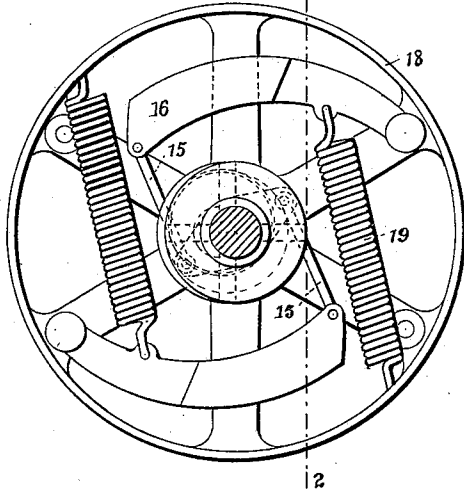

FIG. IX.

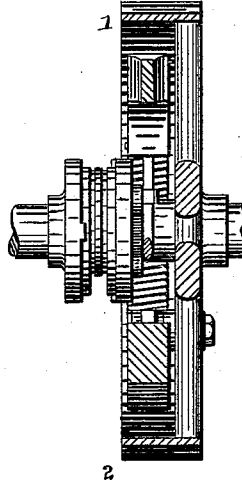

FIG. X.

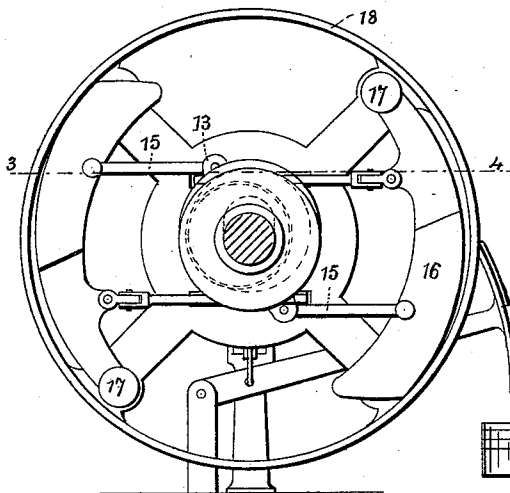
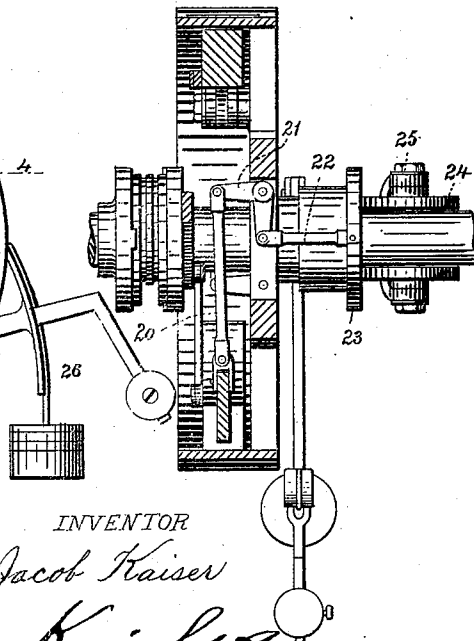

FIG. XI.



WITNESSES.

F. A. St. Clair,
Geo. S. Wheelock.

INVENTOR

Jacob Kaiser
Knight Bros.

ATTORNEYS

UNITED STATES PATENT OFFICE.

JACOB KAISER, OF CLEVELAND, OHIO.

ECCENTRIC-SHIFTING MECHANISM.

SPECIFICATION forming part of Letters Patent No. 352,995, dated November 23, 1886.

Application filed June 2, 1886. Serial No. 203,945. (Model.)

To all whom it may concern:

Be it known that I, JACOB KAISER, a subject of the Emperor of Germany, and a resident of Cleveland, in the county of Cuyahoga and State of Ohio, have invented certain new and useful Improvements in Eccentric-Shifting Mechanisms, of which the following is a specification.

In those governors for the valve-rod of steam-engines in which the amplitude of valve-stroke and the lead of the valve depend upon the relation of a shifting eccentric (controlling the slide-valve) to the main crank it is customary to connect the eccentric movably to the crank-shaft, so that it may be moved in a plane transverse of said shaft by means of centrifugal weights.

My improvements are more particularly intended for engines having a common unbalanced slide-valve, and relate to a construction of the eccentric and of the mechanism for shifting the same which insures its motion in a right line, including the points of maximum and minimum variation, and at the same time renders the gear capable of adjustment, so as to vary the lead alone, the throw of eccentric alone, or simultaneously both the lead and the throw of the eccentric.

In my improved mechanism the eccentric is easily shifted by the action of the governor-weights, but will be firm in any position to which it is adjusted by them, so as to be incapable of dislocation by any external shock or force.

I will first describe my invention with reference to the accompanying drawings, and then point out in the claims the novel features.

Figure I is a side elevation of a portion of a shaft having my improved eccentric. Fig. II is an end elevation of the same. Fig. III is a similar view, the eccentric-shifting disk and connected parts being removed and an eccentric of the form for varying both lead and throw being shown in position. Fig. IV shows in axial section and face view the eccentric-shifting disk. Fig. V shows in face and edge views the form of eccentric employed for changing the stroke of the valve-rod. Fig. VI represents by similar views the form of eccentric employed when the lead is to be regulated. Fig. VII is a side view of the yoke for shifting the eccentric. Fig. VIII is an eleva-

tion of an eccentric spring-governor embodying my invention. Fig. IX is a sectional view of the same in a plane indicated by the line IX IX, Fig. VIII. Fig. X is a view similar to Fig. VIII, showing my present improvements applied to a governor substantially like that shown in my United States Letters Patent No. 333,130, granted December 29, 1885. Fig. XI is a sectional view of the same in a plane indicated by the line XI XI, Fig. X.

1 may represent the crank-shaft of an engine. 2 is a disk rigid with said shaft, and 3 is an eccentric connected to said shaft by means of the disk 2. The means of connection between the disk 2 and the eccentric 3 are a feather or tongue, 4, on the disk 2, occupying a groove, 5, of the eccentric. A slot, 6, is provided in the eccentric 3 in line with the groove 5, so as to permit the eccentric 3 to move upon the feather 4 transversely of the shaft 1. This movement of the eccentric 3 transverse of shaft 1 is effected by a centrifugal governor.

The eccentric 3 bears on its face, opposite groove 5, a groove, 7, in a plane at right angles to the first groove. The groove 7 is occupied by a feather, 8, upon a disk, 9. A hole, 10, is made in the disk 9 of sufficient size to allow the said disk to move freely transversely of the shaft 1 to any necessary position. As the disk 9 thus moves it carries with it the eccentric 3 to a position more or less eccentric on shaft 1. A circular recess, 11, is made eccentrically upon the outer face of disk 9, and this recess is occupied by the circular arm or eccentric 12 of a yoke, 13, whose neck 14 surrounds loosely the shaft 1.

It will be apparent that by oscillating the yoke 13 the eccentric 12 will force disk 9 transversely of shaft 1, and thus effect the adjustment of the eccentric 3. The form of the yoke 13 and its connected parts is shown in Figs. II and VII. Means of oscillation of the yoke 13 may be varied as desired.

In Figs. VIII and IX the improvements are shown applied to an eccentric-shifting governor, in which the weights are counteracted by ordinary spiral springs, while in Figs. X and XI I have shown the adaptation of the improvements to my improved governor described in Letters Patent No. 333,130, already referred to.

In Figs. VIII and IX rods 15 connect the

arms of yoke 13 with the ends of governor-weights 16. The weights 16 have pivotal connection at 17, near the rim of a wheel, 18, rigid with the crank-shaft 1. The centrifugal force of the weights 16, when the shaft is in motion, is counteracted by the spiral springs 19, connected at their ends to the governor-weights 16 and the rim of wheel 18, respectively. It will be seen from an inspection of the face view, Fig. VIII, that increased velocity of rotation of the shaft will give increased centrifugal force to the weights 16, forcing them outwardly against the action of springs 19, and oscillating the yoke 13 upon the shaft 1, so that the eccentric 3 will be forced to travel transversely of the shaft.

In the form of governor shown in Figs. X and XI weights, which may be varied according to the effect desired, are employed for counteracting the centrifugal force of the governor-weights 16, in lieu of the spiral springs 19, Fig. VIII. The construction of the weights 16, their connection by rods 15 with the yoke 13, and pivotal connection with the wheel are similar to the arrangement shown in Fig. VIII. Instead of the spiral springs 19, however, I connect with the weights 16 rods 20, pivoted to the bell-cranks 21, which again are connected with the arms 22 of a spindle, 23. This spindle is thus, when the shaft is in motion, forced outwardly by the centrifugal action of the weights 16 against rollers 24, whose carrying-shaft 25 is controlled by weights 26, in the manner described in my Letters Patent already referred to.

Upon the relation that the line of movement of the eccentric transverse of the shaft bears to the crank on said shaft depends the manner in which such adjustment of the eccentric acts upon the stroke of the slide-valve rod.

In Fig. V the eccentric (whose wrist is indicated by dotted lines) is shown of such form that its movement upon the shaft is in line with the points of maximum and minimum eccentricity. When this form of eccentric is employed, the eccentric will, at slow speed of the engine, rest upon the shaft in the position shown, the shaft being indicated in dotted lines. In this position the greatest length of stroke is provided, and the ports at each movement of the valve-rod are entirely open. At increased speeds, however, the eccentric is forced transversely of the shaft in the direction *a b*, the eccentricity of the eccentric diminishing as the movement continues, until as the eccentric reaches a position on the shaft in which the shaft occupies the opposite end of the slot 6 the ports will remain almost entirely closed and the speed of the engine will correspondingly diminish.

In Fig. VI the relation that the slot 6 (which determines the line of movement of the eccentric) bears to the points of maximum and minimum eccentricity of the eccentric 3 is the reverse of that shown in Fig. V, the slot here lying at right angles to the line connecting such points. It will be seen that in such an arrange-

ment motion of the eccentric transverse of the shaft which is permitted by the slot 6, while not appreciably changing the degree of eccentricity, will change the relation of the points of maximum and minimum eccentricity to the valve or the pitman which operates it, and consequently change the period at which the eccentric—for each revolution of the crank-shaft—will commence to operate the valve-rod. Thus while the shaft is at one extremity of the slot 6 the steam will be entering the cylinder at the commencement of the stroke of the piston, and as the eccentric moves on the shaft till the latter approaches the other extremity of the slot 6 the steam enters at an increasingly early period of the stroke of the piston, and after the shaft has passed the center of the slot the steam will even remain against the piston during a portion of its return-stroke, thus slackening the speed. Figs. V and VI consequently show, respectively, forms of eccentric which are adapted to the changing of the throw of the eccentric alone and the changing of the lead alone.

In Fig. III, I have shown a form in which both the lead and stroke of the valve-rod or throw of the eccentric are regulated simultaneously by the transverse movement of the eccentric. The form here shown involves simply the placing of the slot 6 in a position half-way between the positions shown in Figs. V and VI. The described effect of the movement of an eccentric of this form upon the shaft will be apparent from an inspection of Fig. III.

Both faces of the eccentric 3 are provided with two grooves, arranged at right angles to each other—the one 5, already described, being in line with the slot 6, and for use when the eccentric is to be employed in connection with a governor, as explained; the other, 7, in line with the minor axis of said slot and applied to the tongue 4 of the disk 2 when the relation of the eccentric to the crank-shaft is to remain invariable.

It is apparent that the eccentric 3 may be limited to that portion lying within the dotted lines, Figs. III, V, and VI—in other words, its wrist. The flanges 28 thereon are shown circular, to provide a firm bearing upon disks 2 9.

Having thus described my invention, the following is what I claim as new therein and desire to secure by Letters Patent:

1. The combination, with a crank-shaft and a disk rigid therewith, of a slotted eccentric on said shaft and guided on the face of said disk, a governor, a yoke connected to said governor, and a second disk, slotted for the passage of said shaft, engaged by said yoke and having tongue-and-groove connection with said eccentric, in such manner that the governor shall shift the eccentric transversely of the shaft, substantially as and for the purposes set forth.

2. In combination with a crank-shaft and a disk rigid therewith, a slotted eccentric hav-

ing tongue-and-groove connection with said disk, a second disk slotted for the passage of said shaft, having tongue-and-groove connection with said eccentric, and an eccentric circular recess, a yoke having a circular eccentric arm fitting said recess, and a governor having connection with said yoke, substantially as set forth.

3. In combination with a crank-shaft and a disk rigid thereon and having a tongue upon its face, a slotted eccentric having grooves wherein said tongue can engage, said grooves lying one in line with the major axis of the eccentric-slot and the other in line with its minor axis, a governor, and a yoke connected with said governor and with said eccentric, substantially as and for the purpose set forth.

4. In combination with a crank-shaft, a disk rigid therewith, a slotted eccentric having tongue-and-groove connection with said disk on one face, a second disk movable on the crank-shaft and having tongue-and-groove connection with the opposite face of said eccentric, a yoke engaging said second disk, and a governor for oscillating said disk, substantially as and for the purpose set forth.

5. In combination with a crank-shaft, disks, one rigid therewith and the other loosely movable thereon, an eccentric whose opposite faces engage with said two disks by tongues and grooves arranged transversely to each other,

a yoke having an eccentric engaging in a recess in said loose disk, and a governor for oscillating said disk, substantially as and for the purpose set forth.

6. The combination of a crank-shaft, a slotted eccentric, a disk rigid on said shaft, on which said eccentric is actuated, a yoke engaging with said eccentric for shifting it transversely of the shaft, governor-weights connected with said yoke, a thimble, connecting-rods and bell-cranks between said governor-weights and said thimble, and a weighted lever pressed against said thimble to counteract the action of the governor-weights thereon, substantially as set forth.

7. The combination, with the shaft, the valve-operating eccentric, the governor, and connections between said governor and eccentric, whereby the latter is shifted, of a rectilinear guide for causing said eccentric to move in a line between a line drawn through the points of maximum and minimum eccentricity and a second line drawn at right angles thereto, whereby the "throw" and the "lead" are both regulated by a movement of the eccentric, substantially as set forth.

JACOB KAISER.

Witnesses:

F. A. BEECHER,

C. C. ROGERS.