



US 20040018334A1

(19) **United States**

(12) **Patent Application Publication**
Nee

(10) **Pub. No.: US 2004/0018334 A1**

(43) **Pub. Date: Jan. 29, 2004**

(54) **METAL ALLOYS FOR THE REFLECTIVE OR THE SEMI-REFLECTIVE LAYER OF AN OPTICAL STORAGE MEDIUM**

Related U.S. Application Data

(63) Continuation of application No. 09/834,775, filed on Apr. 13, 2001, now Pat. No. 6,544,616.

(76) Inventor: **Han H. Nee**, Irvine, CA (US)

(60) Provisional application No. 60/219,843, filed on Jul. 21, 2000.

Publication Classification

Correspondence Address:

**Woodard, Emhardt, Moriarty,
McNett & Henry LLP
Bank One Center/Tower
111 Monument Circle, Suite 3700
Indianapolis, IN 46204-5137 (US)**

(51) **Int. Cl.⁷** **B32B 3/02**
(52) **U.S. Cl.** **428/64.1; 428/457; 428/694 RL**

(57) **ABSTRACT**

A silver-based alloy thin film is provided for the highly reflective or semi-reflective coating layer of optical discs. Alloy additions to silver include zinc, aluminum, zinc plus aluminum, manganese, germanium, and copper plus manganese. These alloys have moderate to high reflectivity and reasonable corrosion resistance in the ambient environment.

(21) Appl. No.: **10/409,037**

(22) Filed: **Apr. 8, 2003**

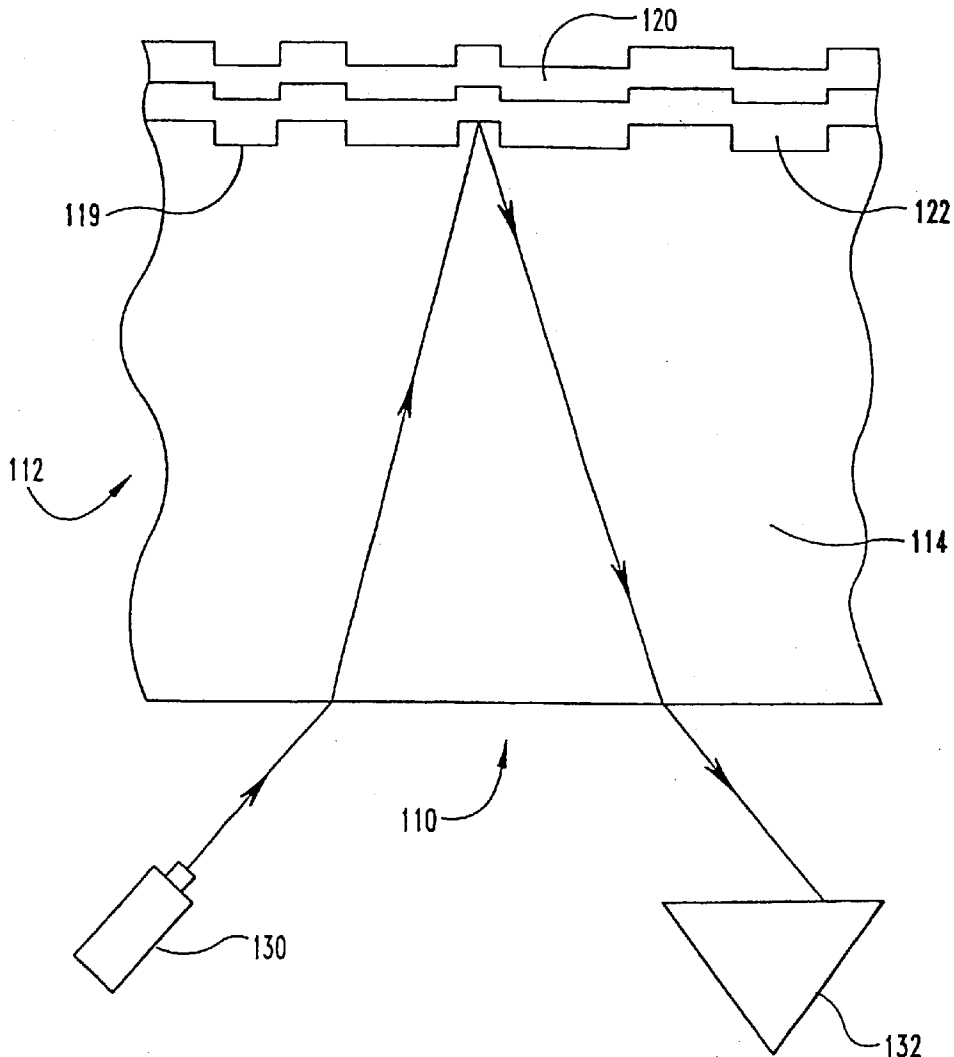

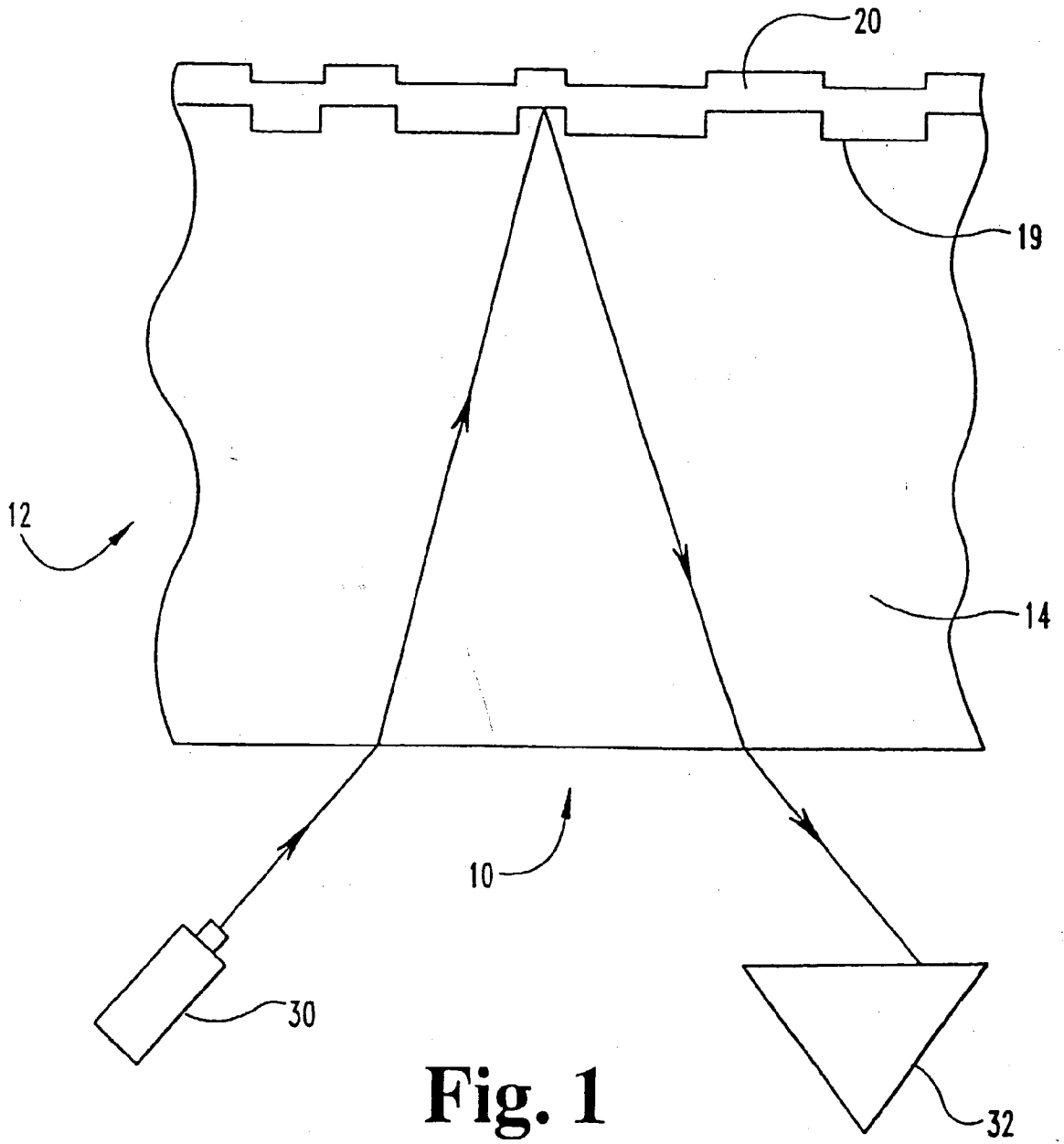

Fig. 1

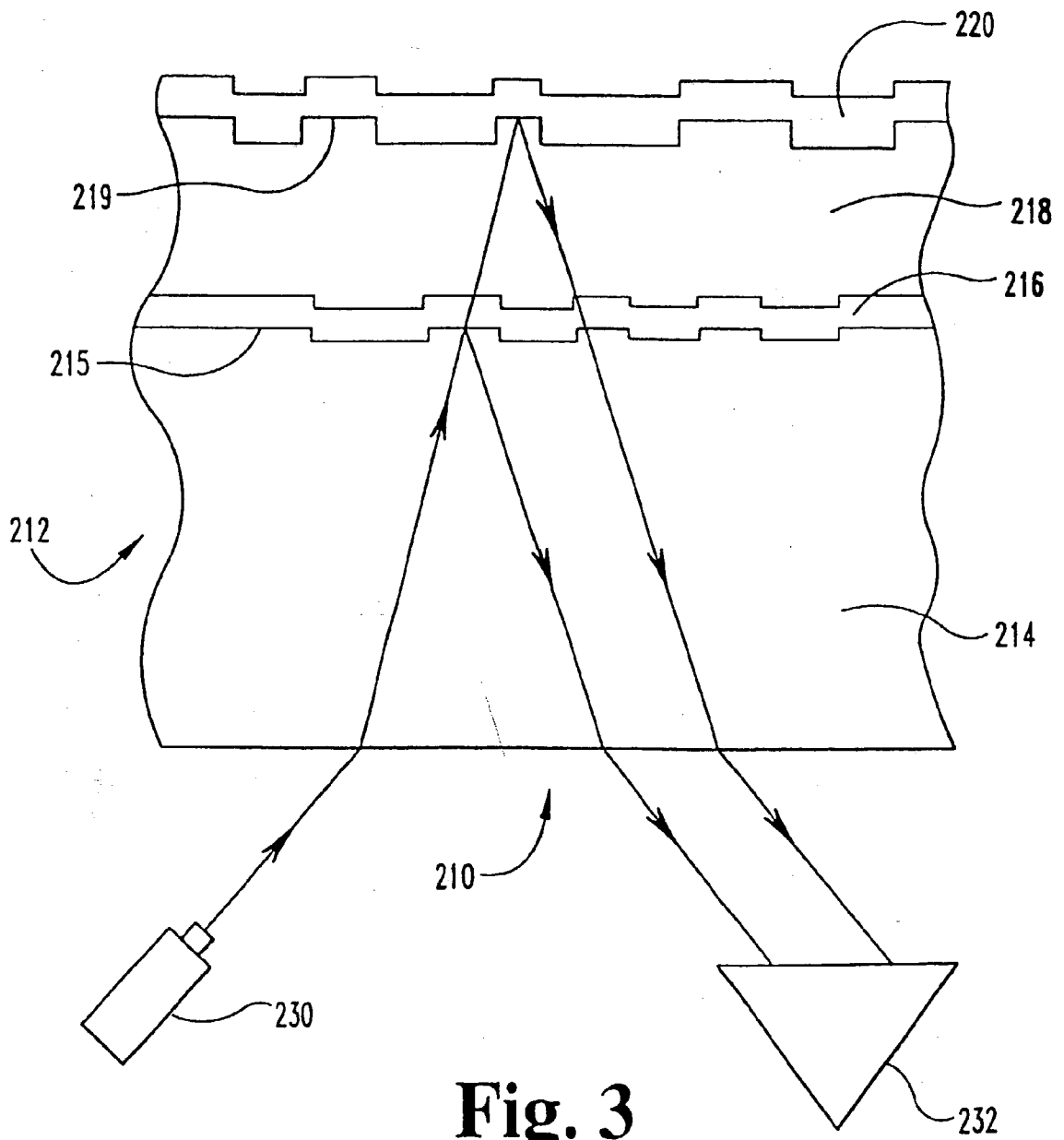

Fig. 3

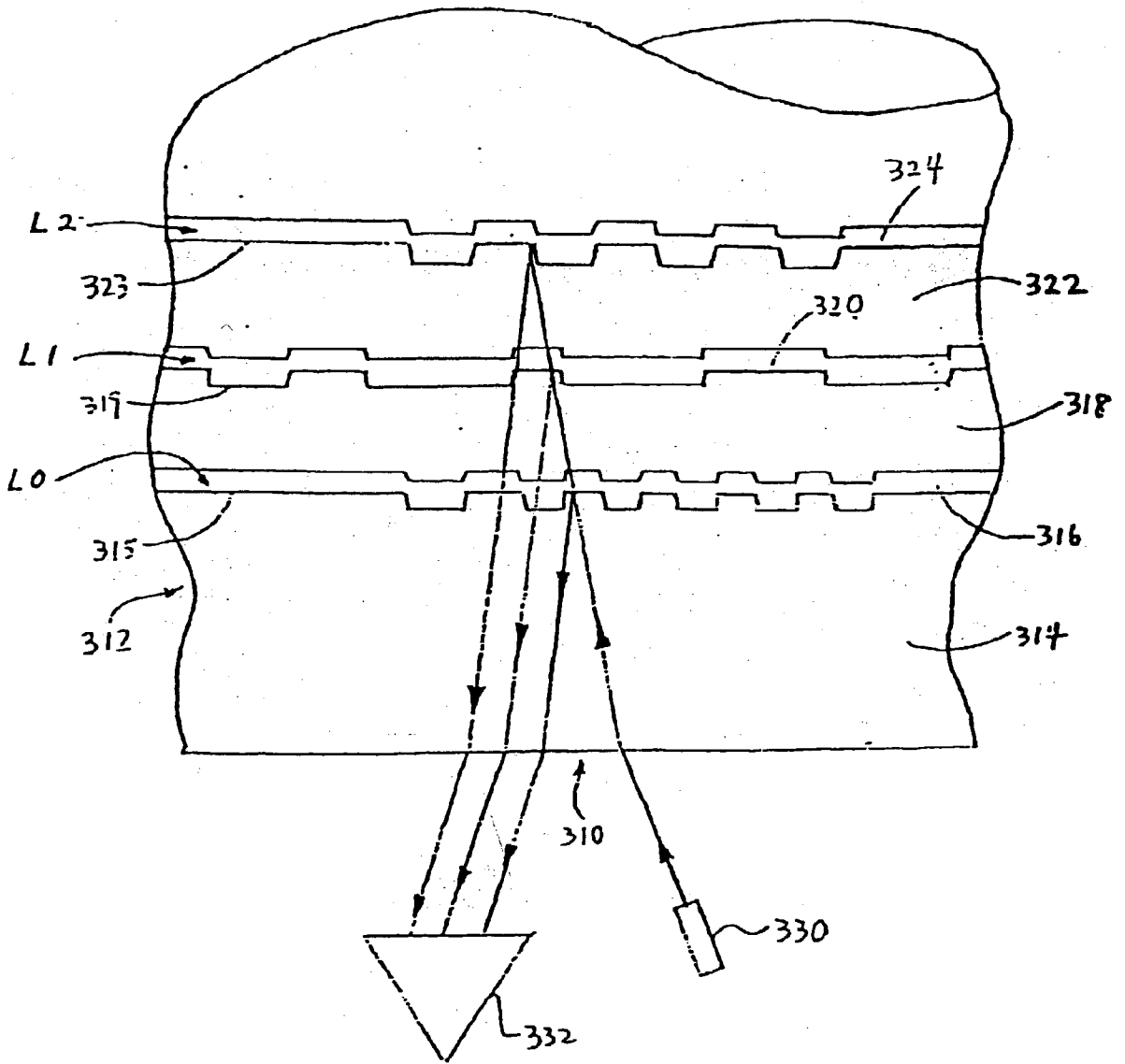

Fig. 4

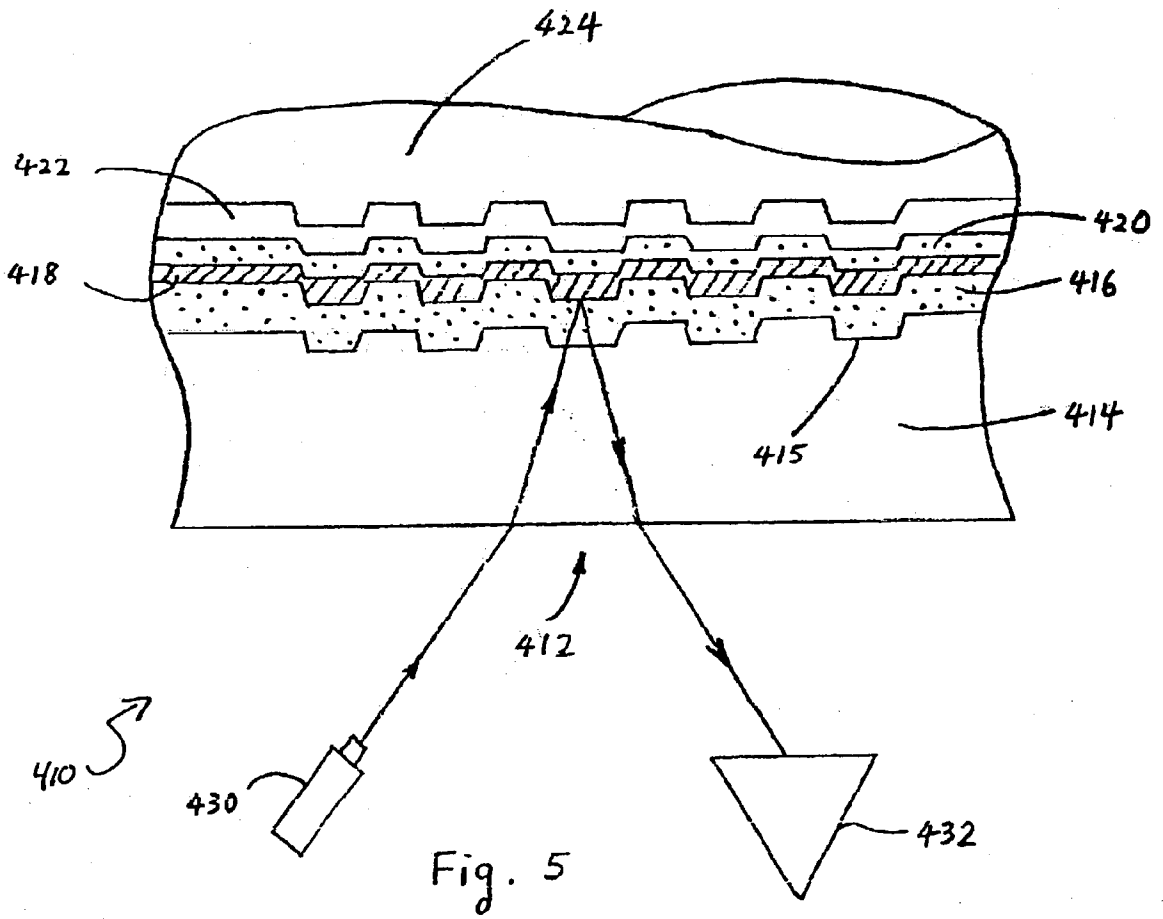

Fig. 5

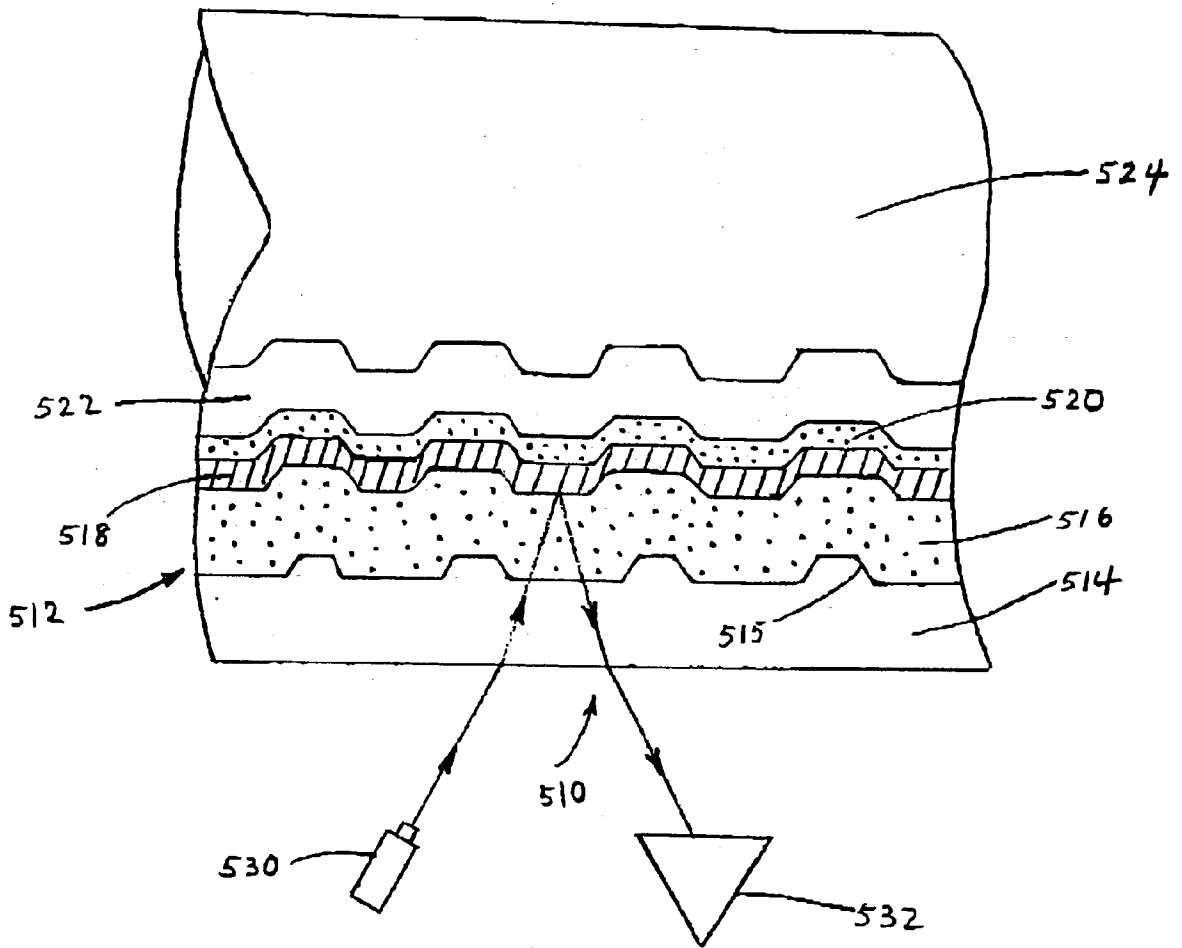

Fig. 6

METAL ALLOYS FOR THE REFLECTIVE OR THE SEMI-REFLECTIVE LAYER OF AN OPTICAL STORAGE MEDIUM

[0001] This patent application is claims priority to U.S. provisional patent application Serial No. 60/219,843.

[0002] This invention relates to reflective layers or semi-reflective layers used in optical storage media that are made of silver-based alloys.

I. BACKGROUND OF THE INVENTION

[0003] Four layers are generally present in the construction of a conventional, prerecorded, optical disc such as compact audio disc. A first layer is usually made from optical grade, polycarbonate resin. This layer is manufactured by well-known techniques that usually begin by injection or compression molding the resin into a disc. The surface of the disc is molded or stamped with extremely small and precisely located pits and lands. These pits and lands have a predetermined size and, as explained below, are ultimately the vehicles for storing information on the disc.

[0004] After stamping, an optically reflective layer is placed over the information pits and lands. The reflective layer is usually made of aluminum or an aluminum alloy and is typically between about 40 to about 100 nanometers (nm) thick. The reflective layer is usually deposited by one of many well-known vapor deposition techniques such as sputtering or thermal evaporation. *Kirk-Othmer, Encyclopedia of Chemical Technology*, 3rd ed. Vol. 10, pp. 247 to 283, offers a detailed explanation of these and other deposition techniques such as glow discharge, ion plating, and chemical vapor deposition, and this specification hereby incorporates that disclosure by reference.

[0005] Next, a solvent-based or an UV (ultraviolet) curing-type resin is applied over the reflective layer, which is usually followed by a label. The third layer protects the reflective layer from handling and the ambient environment. And the label identifies the particular information that is stored on the disc, and sometimes, may include artwork.

[0006] The information pits residing between the polycarbonate resin and the reflective layer usually take the form of a continuous spiral. The spiral typically begins at an inside radius and ends at an outside radius. The distance between any 2 spirals is called the "track pitch" and is usually about 1.6 microns for compact audio disc. The length of one pit or land in the direction of the track is from about 0.9 to about 3.3 microns. All of these details are commonly known for compact audio discs and reside in a series of specifications that were first proposed by Philips NV of Holland and Sony of Japan as standards for the industry.

[0007] The disc is read by pointing a laser beam through the optical grade polycarbonate substrate and onto the reflective layer with sufficiently small resolution to focus on the information pits. The pits have a depth of about $\frac{1}{4}$ of the wavelength of the laser light, and the light generally has a wavelength in the range of about 780 to 820 nanometers. Destructive (dark) or constructive (bright) interference of the laser light is then produced as the laser travels along the spiral track, focusing on an alternating stream of pits and lands in its path.

[0008] This on and off change of light intensity from dark to bright or from bright to dark forms the basis of a digital

data stream of 1 and 0's. When there is no light intensity change in a fixed time interval, the digital signal is "0," and when there is light intensity change from either dark to bright or bright to dark, the digital signal is "1." The continuous stream of ones and zeros that results is then electronically decoded and presented in a format that is meaningful to the user such as music or computer programming data.

[0009] As a result, it is important to have a highly reflective coating on the disc to reflect the laser light from the disc and onto a detector in order to read the presence of an intensity change. In general, the reflective layer is usually aluminum, copper, silver, or gold, all of which have a high optical reflectivity of more than 80 percent from 650 nm to 820 nm wavelength. Aluminum and aluminum alloys are commonly used because they have a comparatively lower cost, adequate corrosion resistance, and are easily placed onto the polycarbonate disc.

[0010] Occasionally and usually for cosmetic reason, a gold or copper based alloy is used to offer the consumer a "gold" colored disc. Although gold naturally offers a rich color and satisfies all the functional requirements of a highly reflective layer, it is comparatively much more expensive than aluminum. Therefore, a copper-based alloy that contains zinc or tin is sometimes used to produce the gold colored layer. But unfortunately, the exchange is not truly satisfactory because the copper alloy's corrosion resistance, in general, is considered worse than aluminum, which results in a disc that has a shorter life span than one with an aluminum reflective layer.

[0011] For the convenience of the reader, additional details in the manufacture and operation of an optically readable storage system can be found in U.S. Pat. Nos. 4,998,239 to Strandjord et al. and 4,709,363 to Dirks et al., the disclosures of which are hereby incorporated by reference.

[0012] Another type of disc in the compact disc family that has become popular is the recordable compact disc or "CD-R." This disc is similar to the CD described earlier, but it has a few changes. The recordable compact disc begins with a continuous spiral groove instead of a continuous spiral of pits and has a layer of organic dye between the polycarbonate substrate and the reflective layer. The disc is recorded by periodically focusing a laser beam into the grooves as the laser travels along the spiral track. The laser heats the dye to a high temperature, which in turn places pits in the groove that coincide with an input data stream of ones and zeros by periodically deforming and decomposing the dye.

[0013] For the convenience of the reader, additional details regarding the operation and construction of these recordable discs can be found in U.S. Pat. Nos. 5,325,351 to Uchiyama et al., and 5,391,462; 5,415,914; and 5,419,939 to Arioka et al., and 5,620,767 to Harigaya et al., the disclosures of which are hereby incorporated into this specification by reference.

[0014] The key component of a CD-R disc is the organic dye, which is made from solvent and one or more organic compounds from the cyanine, phthalocyanine or azo family. The disc is normally produced by spin coating the dye onto the disc and sputtering the reflective layer over the dye after the dye is sufficiently dry. But because the dye may contain

halogen ions or other chemicals that can corrode the reflective layer, many commonly used reflective layer materials such as aluminum may not be suitable to give the CD-R disc a reasonable life span. So being, frequently gold must be used to manufacture a recordable CD. But while gold satisfies all the functional requirements of CD-R discs, it is a very expensive solution.

[0015] Recently, other types of recordable optical disks have been developed. These optical disks use a phase-change or magneto-optic material as the recording medium. An optical laser is used to change the phase or magnetic state (microstructural change) of the recording layer by modulating a beam focused on the recording medium while the medium is rotated to produce microstructural changes in the recording layer. During playback, changes in the intensity of light from the optical beam reflected through the recording medium are sensed by a detector. These modulations in light intensity are due to variations in the microstructure of the recording medium produced during the recording process. Some phase-change and/or magneto-optic materials may be readily and repeatedly transformed from a first state to a second state and back again with substantially no degradation. These materials may be used as the recording media for a compact disc-rewritable disc, or commonly known as CD-RW.

[0016] To record and read information, phase change discs utilize the recording layer's ability to change from a first dark to a second light phase and back again. Recording on these materials produces a series of alternating dark and light spots according to digital input data introduced as modulations in the recording laser beam. These light and dark spots on the recording medium correspond to 0's and 1's in terms of digital data. The digitized data is read using a low laser power focused along the track of the disc to play back the recorded information. The laser power is low enough such that it does not further change the state of the recording media but is powerful enough such that the variations in reflectivity of the recording medium may be easily distinguished by a detector. The recording medium may be erased for re-recording by focussing a laser of intermediate power on the recording medium. This returns the recording medium layer to its original or erased state. A more detailed discussion of the recording mechanism of optically recordable media can be found in U.S. Pat. Nos. 5,741,603; 5,498,507; and 5,719,006 assigned to the Sony Corporation, the TDK Corporation, and the NEC Corporation, all of Tokyo, Japan, respectively, the disclosures of which are incorporated herein by reference in their entirety.

[0017] Still another type of disc in the optical disc family that has become popular is a prerecorded optical disc called the digital videodisc or "DVD." This disc has two halves. Each half is made of polycarbonate resin that has been injection or compression molded with pit information and then sputter coated with a reflective layer, as described earlier. These two halves are then bonded or glued together with an UV curing resin or a hot melt adhesive to form the whole disc. The disc can then be played from both sides as contrasted from the compact disc or CD where information is usually obtained only from one side. The size of a DVD is about the same as a CD, but the information density is considerably higher. The track pitch is about 0.7 micron and the length of the pits and lands is from approximately 0.3 to 1.4 microns.

[0018] One variation of the DVD family of discs is the DVD-dual layer disc. This disc also has two information layers; however, both layers are played back from one side. In this arrangement, the highly reflectivity layer is usually the same as that previously described. But the second layer is only semi-reflective with a reflectivity in the range of approximately 18 to 30 percent at 650 nm wavelength. In addition to reflecting light, this second layer must also pass a substantial amount of light so that the laser beam can reach the highly reflective layer underneath and then reflect back through the semi-reflective layer to the signal detector.

[0019] In a continued attempt to increase the storage capacity of optical discs, a multi-layer disc can be constructed as indicated in the publication "SPIE Conference Proceeding Vol. 2890, page 2-9, Nov, 1996" where a tri-layer or a quadri-layer optical disc was revealed. All the data layers were played back from one side of the disc using laser light at 650 nm wavelength. A double-sided tri-layered read-only-disc that included a total of six layers can have a storage capacity of about 26 gigabytes of information.

[0020] More recently, a blue light emitting laser diode with wavelength of 400 nm has been made commercially available. The new laser will enable much denser digital videodisc data storage. While current DVD using 650 nm red laser can store 4.7 GB per side, the new blue laser will enable 12 GB per side, enough storage space for about 6 hours of standard-resolution video and sound. With a multi-layer disc, there is enough capacity for a featured movie in the high-definition digital video format. Silver alloys of the present invention can be used for any one layer of the multi-layer optical disc.

[0021] Currently, there is an interest in adapting CD-RW techniques to the DVD field to produce a rewritable DVD (DVD-RW). Some difficulties in the production of a DVD-RW have arisen due to the higher information density requirements of the DVD format. For example, the reflectivity of the reflective layer must be increased relative that of the standard DVD reflective layer to accommodate the reading, writing, and erasing requirements of the DVD-RW format. Also, the thermal conductivity of the reflective layer must also be increased to adequately dissipate the heat generated by both the higher laser power requirements to write and erase information and the microstructural changes occurring during the information transfer process. The potential choice of the reflective layer is currently pure gold, pure silver and aluminum alloys. Gold seems to have sufficient reflectivity, thermal conductivity, and corrosion resistance properties to work in a DVD-RW disk. Additionally, gold is relatively easy to sputter into a coating of uniform thickness. But once again, gold is also comparatively more expensive than other metals, making the DVD-RW format prohibitively expensive. Pure silver has higher reflectivity and thermal conductivity than gold, but its corrosion resistance is relatively poor as compared to gold. Aluminum alloy's reflectivity and thermal conductivity is considerably lower than either gold or silver, and therefore is not necessarily a good choice for the reflective layer in DVD-RW or DVD+RW.

[0022] For the convenience of the reader, additional details regarding the manufacture and construction of DVD discs can be found in U.S. Pat. No. 5,640,382 to Florczak et al. the disclosure of which is hereby incorporated by reference.

[0023] Therefore, what is needed are some new alloys that have the advantages of gold when used as a reflective layer or as a semi-reflective layer in an optical storage medium, but are not as expensive as gold. These new alloys also have better corrosion resistance than pure silver. The current invention addresses that need.

II. SUMMARY OF THE INVENTION

[0024] In one aspect, this invention is an optical storage medium with a first substrate having a pattern of features in at least one major surface and a first reflective layer adjacent the feature pattern. The reflective layer is made of a silver and zinc alloy where the relationship between the amount of silver and the amount of zinc is defined by Ag_xZn_y , where $0.85 < x < 0.9999$ and $0.0001 < y < 0.15$.

[0025] In another aspect, this invention is an optical storage medium with a first substrate having a pattern of features in at least one major surface and a first reflective layer adjacent the feature pattern. The reflective layer is made of a silver and aluminum alloy where the relationship between the amount of silver and the amount of aluminum is defined by Ag_xAl_z where $0.95 < x < 0.9999$ and $0.0001 < z < 0.05$.

[0026] In another aspect, this invention is an optical storage medium with a first substrate having a pattern of features in at least one major surface and a first reflective layer adjacent the feature pattern. The reflective layer is made of a silver and zinc and aluminum alloy where the relationship between the amount of silver and the amount of zinc and the amount of aluminum is defined by $Ag_xZn_yAl_z$ where $0.80 < x < 0.998$ and $0.001 < y < 0.15$, and $0.001 < z < 0.05$.

[0027] In another aspect, this invention is an optical storage medium with a first substrate having a pattern of features in at least one major surface and a first reflective layer adjacent the feature pattern. The reflective layer is made of a silver and manganese alloy where the relationship between the amount of silver and manganese is defined by Ag_xMn_t where $0.925 < x < 0.9999$ and $0.0001 < t < 0.075$.

[0028] In another aspect, this invention is an optical storage medium with a first substrate having a pattern of features in at least one major surface and a first reflective layer adjacent the feature pattern. The reflective layer is made of a silver and germanium alloy where the relationship between the amount of silver and the amount of germanium is defined by Ag_xGe_q where $0.97 < x < 0.9999$ and $0.0001 < q < 0.03$.

[0029] In another aspect, this invention is an optical storage medium with a first substrate having a pattern of features in at least one major surface and a first reflective layer adjacent the feature pattern. The reflective layer is made of a silver and copper and manganese alloy where the relationship between the amount of silver and the amount of copper and the amount of manganese is defined by $Ag_xCu_pMn_t$ where $0.825 < x < 0.9998$ and $0.0001 < p < 0.10$, and $0.0001 < t < 0.075$.

[0030] It is an objective of this invention to provide a new metallic alloy for thin film reflective layers that have high reflectivity and similar sputtering characteristics as gold, and is corrosion resistant and yet inexpensive. When a layer of this invention is made thin enough, it can be semi-reflective and transmissive to laser light for the application of DVD-dual layer.

[0031] It is another objective of this invention to provide a lower cost alternative to the gold reflective layer in a recordable compact disc and still satisfy other functional requirements of the disc such as high reflectivity and corrosion resistance.

[0032] It is a further objective of this invention to provide a silver-based alloy with sufficient chemical, thermal and optical properties to satisfy the functional requirements of the reflective layer in a DVD-RW or DVD+RW disc and other current or future generations of optical discs in which reflectivity, corrosion resistance, and ease of application are all important requirements for a low cost and high performance product.

III. BRIEF DESCRIPTION OF THE DRAWINGS

[0033] FIG. 1 is an optical storage system according to one embodiment of this invention.

[0034] FIG. 2 is an optical storage system according to another embodiment of this invention where an organic dye is used as a recording layer.

[0035] FIG. 3 is an optical storage system according to another embodiment of this invention with two layers of information pits where the playback of both layers is from one side.

[0036] FIG. 4 is an optical storage system according to another embodiment of this invention with three layers of information pits where the playback of all three layers is from one side.

[0037] FIG. 5 is an optical storage system according to another embodiment of this invention where the system contains a rewritable information layer.

[0038] FIG. 6 is an optical storage system according to another embodiment of this invention where the system contains a rewritable information layer.

IV. DESCRIPTION OF PREFERRED EMBODIMENTS

[0039] Specific language is used in the following description and examples to publicly disclose the invention and to convey its principles to others. No limits on the breadth of the patent rights based simply on using specific language are intended. Also included are any alterations and modifications to the descriptions that should normally occur to one of average skill in this technology.

[0040] As used in this specification the term "atomic percent" or "a/o percent" refers to the ratio of atoms of a particular element or group of elements to the total number of atoms that are identified to be present in a particular alloy. For example, an alloy that is 15 atomic percent element "A" and 85 atomic percent element "B" could also be referenced by a formula for that particular alloy: $A_{0.15}B_{0.85}$.

[0041] As used herein the term "of the amount of silver present" is used to describe the amount of a particular additive that is included in the alloy. Used in this fashion, the term means that the amount of silver present, without consideration of the additive, is reduced by the amount of the additive that is present to account for the presence of the additive in a ratio. For example, if the relationship between Ag and an element "X" is $Ag_{0.85}X_{0.15}$ (respectively 85 a/o

percent and 15 a/o percent) without the considering the amount of the additive that is present, and if an additive "B" is present at a level 5 atomic percent "of the amount of silver present"; then the relationship between Ag, X, and B is found by subtracting 5 atomic percent from the atomic percent of silver, or the relationship between Ag, X, and B is $Ag_{0.80} X_{0.15} B_{0.05}$ (respectively 80 a/o percent silver, 15 a/o percent "X", and 5 a/o percent "B").

[0042] As used in this specification the term "adjacent" refers to a spatial relationship and means "nearby" or "not distant." Accordingly, the term "adjacent" as used in this specification does not require that items so identified are in contact with one another and that they may be separated by other structures. For example, referring to FIG. 5, layer 424 is "adjacent" or "nearby" layer 422, just as layer 414 is "adjacent" or "nearby" layer 422.

[0043] This invention comprises multi-layer metal/substrate compositions that are used as optical data storage media. One embodiment of this invention is shown in FIG. 1 as optical data storage system 10. Optical storage medium 12 comprises a transparent substrate 14, and a highly reflective thin film layer or coating 20 on a first data pit pattern 19. An optical laser 30 emits an optical beam toward medium 12, as shown in FIG. 1. Light from the optical beam that is reflected by thin film layer 20 is sensed by detector 32, which senses modulations in light intensity based on the presence or absence of a pit or land in a particular spot on the thin film layer. The disc is unique in that one of the alloys presented below is deposited upon the information pits and lands and is used as the highly reflective thin film 20. In one alternative (not shown), the disc may be varied by attaching two optical storage media 12 back-to-back, that is, with each transparent substrate 14 facing outward.

[0044] Another embodiment of this invention is shown in FIG. 2 as optical data storage system 110. Optical storage medium 112 comprises a transparent substrate 114, and a highly reflective thin film layer 120, over a layer of dye 122, placed over a first pattern 119. An optical laser 130 emits an optical beam toward medium 112, as shown in FIG. 2. As discussed earlier, data is placed upon the disc by deforming portions of the dye layer with a laser. Thereafter, the disc is played by light from the optical beam, which is reflected by thin film layer 120 and sensed by detector 132. Detector 132 senses modulations in light intensity based on the presence or absence of a deformation in the dye layer. The disc is unique in that one of the alloys presented below is deposited over the dye layer 122 and is used as the highly reflective thin film or coating 120. In one alternative (not shown), the disc may be varied by attaching two optical storage media 112 back-to-back, that is, with each transparent substrate 114 facing outward.

[0045] Another embodiment of this invention is shown in FIG. 3 as optical data storage system 210. Optical storage medium 212 comprises a transparent substrate 214, a partially reflective thin film layer or coating 216 on a first data pit pattern 215, a transparent spacer layer 218, and a highly reflective thin film layer or coating 220 on a second data pit pattern 219. An optical laser 230 emits an optical beam toward medium 212, as shown in FIG. 3. Light from the optical beam that is reflected by either thin film layer 216 or 220 is sensed by detector 232, which senses modulations in light intensity based on the presence or absence of a pit in

a particular spot on the thin film layers. The disc is unique in that one of the alloys presented below is deposited upon the information pits and lands and used as the highly reflective thin film 220 or semi-reflective layer 216. In another alternative (not shown), the disc may be varied by attaching two optical storage media 212 back-to-back, that is, with each transparent substrate 214 facing outward. The attachment method could be by UV cured adhesive, hot melt adhesive or other type of adhesives.

[0046] Another embodiment of this invention is shown in FIG. 4 as optical data storage system 310. Optical storage medium 312 comprises a transparent substrate 314, a partially reflective thin film layer or coating 316 or layer "zero" on a first data pit pattern 315, a transparent spacer layer 318, another partially reflective thin film layer or coating 320 or layer "one" on a second data pit pattern 319, a second transparent spacer layer 322, and a highly reflective thin film layer or coating 324 or layer "two" on a third pit pattern 323. An optical laser 330 emits an optical beam toward medium 312, as shown in FIG. 4. Light from the optical beam that is reflected by thin film layer 316, 320 or 324 is detected by detector 332, which senses modulation in light intensity based on the presence or absence of a pit in a particular spot on the thin film layers. The disc is unique in that any or all of the alloys presented below can be deposited upon the information pits and lands and used as the highly reflective thin film or coating 324 or the semi-reflective layer or coating 316 and 320. To playback the information on Layer 2, the light beam from laser diode 330 is going through the transparent polycarbonate substrate, passing through the first semi-reflective Layer 0, and the second semi-reflective Layer 1 and then reflected back from layer 2 to the detector 332. In another alternative (not shown), the disc may be varied by attaching two optical storage media 312 back-to-back, that is, with each transparent substrate 314 facing outward. The attachment method could be by UV cured adhesive, hot melt adhesive or other type of adhesives.

[0047] Still another embodiment of this invention is shown in FIG. 5 as optical data storage system 410. Optical storage medium 412 comprises a transparent substrate or a transparent layer 414, a dielectric layer 416 on a first data pit pattern 415, a recording layer 418 made of a material having a microstructure including domains or portions capable of repeatedly undergoing laser-induced transitions from a first state to a second state and back again (i.e., an optically re-recordable or rewritable layer), such as a phase change material or a magneto-optic material, another dielectric material 420, a highly reflective thin film layer 422, and a transparent substrate or layer 424. As used in this specification, a dielectric material is a material that is an electrical insulator or in which an electric field can be sustained with a minimum dissipation of power. The different layers 414, 416, 418, 420 and 422 of the optical storage medium 410 are preferably oriented so as to be adjacent with one another.

[0048] Commonly used phase change materials for the recording layer 418 include germanium-antimony-tellurium (Ge—Sb—Te), silver-indium-antimony-tellurium (Ag—In—Sb—Te), chromium-germanium-antimony-tellurium (Cr—Ge—Sb—Te) and the like. Commonly used materials for the dielectric Layer 416 or 420 include zinc sulfide-silica compound. ($ZnS.SiO_2$), silicon nitride (SiN), aluminum nitride (AlN) and the like. Commonly used magneto-optic materials for the recording layer 418 include terbium-iron-

cobalt (Tb—Fe—Co) or gadolinium-terbium-iron (Gd—Tb—Fe). An optical laser **430** emits an optical beam toward medium **412**, as shown in **FIG. 5**. In the recording mode for the phase change recordable optical medium, light from the optical beam is modulated or turned on and off according to the input digital data and focused on the recording layer **418** with suitable objective while the medium is rotated in a suitable speed to effect microstructural or phase change in the recording layer. In the playback mode, the light from the optical beam that is reflected by the thin film layer **422** through the medium **412** is sensed by the detector **432**, which senses modulations in light intensity based on the crystalline or amorphous state of a particular spot in the recording layers. The disc is unique in that one of the alloys presented below is deposited upon the medium and used as the highly reflective thin film **422**. In another alternative (not shown), the disc may be varied by attaching two optical storage media **412** back-to-back, that is, with each transparent substrate or coating **414** facing outward. The attachment method could be by UV cured adhesive, hot melt adhesive or other type of adhesives.

[**0049**] As shown in **FIG. 5**, if the thickness of the transparent substrate **414** is about 1.2 mm thick made of injection molded polycarbonate with continuous spirals of grooves and lands, **424** is a UV cured acrylic resin 3 to 15 micron in thickness acting as a protective layer with the playback laser **430** at 780 to 820 nanometer, and the rewritable layer **418** is a phase change material of a typical composition such as Ag—In—Sb—Te, it is a structure of a compact disc-rewritable disc, or commonly known as CD-RW. To record and read information, phase change discs utilize the recording layer's ability to change from an amorphous phase with low reflectivity (dark) to a crystalline phase with high reflectivity (bright). Before recording, the phase change layer is in a crystalline state. During recording, a laser beam with high power focused on the recording layer will heat the phase change material to high temperature and when the laser is turned off, the heated spot cools off very fast to create an amorphous state. Thus a series of dark spots of amorphous states are created according to the input data of turning the focused laser beam on and off. These on and off correspond to "0" and "1" of a digital data stream.

[**0050**] In reading, a low laser power is used to focus on and read the dark or bright spots along the track of the disc to play back the recorded information. To erase, an intermediate laser power is used to focus on the grooves or tracks with the disc spinning so that an intermediate temperature of the focused spots is reached. After the laser spots are moved to another location, the spots cool to room temperature with a crystalline structure of high reflectivity. This returns the recording layer to its original or erased state. The change of the spots from amorphous to crystalline state is very reversible, thus many record and erase cycles can be accomplished and different data can be repeatedly recorded and read back with no difficulty.

[**0051**] If the thickness of the transparent substrate **414** is about 0.5 to 0.6 mm thick made of injection molded polycarbonate with continuous spirals of grooves and lands, with **416** and **420** being the dielectric layers made of typically ZnS.SiO₂, and **418** is made of a phase change material such as Ag—In—Sb—Te or Ge—Sb—Te, with **422** made of a silver alloy of the current invention, and **424** is a UV cured resin bonding another half of the same structure as depicted

in **FIG. 5**, with the read and write laser **430** at 630 to 650 nanometer wavelength, then it is a digital versatile disc with rewritable capability or commonly referred to as DVD+RW. Some preferred phase-changeable materials include materials from the following series: As—Te—Ge, Te—Ge—Sn, Te—Ge—Sn—O, Te—Se, Sn—Te—Se, Te—Ge—Sn—Au, Ge—Sb—Te, Sb—Te—Se, In—Se—Tl, In—Sb, In—Sb—Se, In—Se—Tl—Co, Cr—Ge—Sb—Te and Si—Te—Sn, where As is arsenic, Te is tellurium, Ge is germanium, Sn is tin, O is oxygen, Se is selenium, Au is gold, Sb is antimony, In is indium, Tl is thallium, Co is cobalt, and Cr is chromium. In this disc configuration, the highly reflective layer **422** needs not only high reflectivity at 650 nanometer wavelength and high thermal conductivity, but also high corrosion resistance against ZnS.SiO₂. Conventional aluminum alloy does not have high enough reflectivity nor high enough thermal conductivity. Pure silver or other conventional silver alloys do not have either high corrosion resistance or high reflectivity and high thermal conductivity. Thus it is another objective of the current invention to provide a series of silver alloy that can meet the requirements for this application.

[**0052**] Another embodiment of the current invention is shown in **FIG. 6** as an optical information storage system **510** of the rewritable type. Transparent cover layer **514** is approximately 0.1 mm in thickness. Dielectric layers **516** and **520** are preferably made of ZnS.SiO₂ and serve as a protective layer for the rewritable layer or phase change layer **518**. Rewritable layer **518** is preferably formed from Ag—In—Sb—Te or the like. Highly reflective layer **522** is preferably formed from a silver alloy, such as disclosed herein. Transparent substrate **524** is preferably approximately 1.1 mm in thickness with continuous spiral tracks of grooves and land usually made with polycarbonate resin. Laser **530** preferably has a wavelength of about 400 nm with associated optics to focus the laser beam on to the recording layer **518**. The reflected laser beam is received by the detector **532**, which preferably includes associated data processing capability to read back the recorded information. This system **510** is sometimes called a "Digital Video Recording System" or DVR designed to record high definition TV signal. The principle of operation of this optical information storage system **510** is about the same as a CD-RW disc except the recording density is considerably higher and the storage capacity of a 5-inch diameter disc is approximately 20 gigabytes. Again the performance of the disc stack depends on a highly reflective, layer **522** at 400 nm wavelength with high corrosion resistance and very high thermal conductivity. Conventional reflective layer such as aluminum, gold or copper all have difficulty meeting this requirement. Thus it is another objective of the current invention to provide a silver alloy reflective layer that is capable of meeting these demanding requirements.

[**0053**] As used herein, the term "reflectivity" refers to the fraction of optical power incident upon transparent substrate **14**, **114**, **214**, **314**, **414** or **514** which, when focused to a spot on a region of layer **20**, **120**, **216**, **220**, **316**, **320**, **324**, **422** or **522** could in principle, be sensed by a photodetector in an optical readout device. It is assumed that the readout device includes a laser, an appropriately designed optical path, and a photodetector, or the functional equivalents thereof.

[**0054**] This invention is based on the inventor's discovery that a particular silver-based alloy provides sufficient reflec-

tivity and corrosion resistance to be used as the reflective or the semi-reflective layer in an optical storage medium, without the inherent cost of a gold-based alloy or the process complication of a silicon-based material. In one embodiment, the silver is alloyed with a comparatively small amount of zinc. In this embodiment, the relationship between the amounts of zinc and silver ranges from about 0.01 a/o percent (atomic percent) to about 15 a/o percent zinc and from about 85 a/o percent to about 99.99 a/o percent silver. But preferably in respect to each metal, the alloy has from about 0.1 a/o percent to about 10.0 a/o percent zinc and from about 90.0 a/o percent to about 99.9 a/o percent silver.

[0055] In another embodiment, the silver is alloyed with a comparatively small amount of aluminum. In this embodiment, the relationship between the amounts of aluminum and silver ranges from about 0.01 a/o percent (atomic percent) to about 5 a/o percent aluminum and from about 95 a/o percent to about 99.99 a/o percent silver. But preferably in respect to each metal, the alloy has from about 0.1 a/o percent to about 3.0 a/o percent aluminum and from about 97 a/o percent to about 99.9 a/o percent silver.

[0056] In another embodiment of the present invention, the silver-based, binary alloy systems as mentioned above are further alloyed with cadmium (Cd), lithium (Li), or manganese (Mn). If one or more of these metals replaces a portion of the silver in the alloy, the corrosion resistance of the resultant thin film will likely increase; however, the reflectivity will also likely drop. The amount of cadmium, lithium, or manganese that may favorably replace some of the silver in the binary alloy ranges from about 0.01 a/o percent to about 20 a/o percent of the amount of silver present for cadmium, from about 0.01 a/o percent to about 10 a/o percent or even to about 15 a/o percent of the amount of silver present for lithium, and from about 0.01 a/o percent to about 7.5 a/o percent of the amount of silver present for manganese.

[0057] In still another embodiment of the present invention, the silver-based, zinc and aluminum binary alloy systems as mentioned above are further alloyed with a precious metal such as gold (Au), rhodium (Rh), copper (Cu), ruthenium (Ru), osmium (Os), iridium (Ir), platinum (Pt), palladium (Pd), and mixtures thereof, which may be added to the above binary alloys with the preferable range of precious metal to be about 0.01 a/o to 5.0 a/o percent of the amount of silver present. In addition to the precious metals, the above alloys may be still further alloyed with a metal such as titanium (Ti), nickel (Ni), indium (In), chromium (Cr), germanium (Ge), tin (Sn), antimony (Sb), gallium (Ga), silicon (Si), boron (B), zirconium (Zr), molybdenum (Mo), and mixtures thereof. In relation to the amount of silver that is present in the above silver alloy system, the amount of these metals that may be preferably added ranges from about 0.01 a/o percent to about 5.0 a/o of the amount of silver present.

[0058] In still another embodiment, the silver is alloyed with a comparatively small amount of both zinc and aluminum. In this embodiment, the relationship between the amounts of zinc, aluminum and silver ranges from about 0.1 a/o percent to about 15 a/o percent zinc, from about 0.1 a/o percent to about 5 a/o percent aluminum, and from about 80 a/o percent to about 99.8 a/o percent silver. But preferably

in respect to each metal, the alloy has from about 0.1 a/o percent to about 5.0 a/o percent zinc, from about 0.1 a/o percent to about 3.0 a/o percent aluminum, and from about 92.0 a/o percent to about 99.8 a/o percent silver.

[0059] In yet another embodiment of the present invention, the silver-based zinc-aluminum ternary alloy system as mentioned above is further alloyed with a fourth metal. The fourth metal may include manganese or nickel. If one or a mixture of these metals replaces a portion of the silver in the alloy, the corrosion resistance of the resultant thin film will likely increase; however, the reflectivity will also likely drop. The amount of manganese or nickel that may favorably replace some of the silver in the above ternary alloy ranges from about 0.01 a/o percent to about 7.5 a/o percent of the amount of silver present for manganese, with a preferable range being between about 0.01 a/o percent and about 5.0 a/o percent of the amount of silver present. The amount of nickel may range from between about 0.01 a/o percent to about 5.0 a/o percent of the amount of silver present with a preferable range being between from about 0.01 a/o percent and about 3.0 a/o percent of the amount of silver present.

[0060] In still another embodiment of the present invention, the silver-based zinc-aluminum ternary alloy system as mentioned above is further alloyed with a precious metal such as gold, rhodium, copper, ruthenium, osmium, iridium, platinum, palladium, and mixtures thereof, which may be added to the above ternary alloys with the preferable range of precious metal to be about 0.01 a/o to 5.0 a/o percent of the amount of silver present. In addition to the precious metals, the above alloys may also be alloyed with a metal such as titanium, nickel, indium, chromium, germanium, tin, antimony, gallium, silicon, boron, zirconium, molybdenum, and mixtures thereof. In relation to the amount of silver that is present in the above silver alloy system, the amount of such metals that may be preferably added ranges from about 0.01 a/o percent to about 5.0 a/o percent of the amount of silver present.

[0061] In another embodiment, the silver is alloyed with a comparatively small amount of manganese. In this embodiment, the relationship between the amounts of manganese and silver ranges from about 0.01 a/o percent to about 7.5 a/o percent manganese and from about 92.5 a/o percent to about 99.99 a/o percent silver. But preferably in respect to each metal, the alloy has from about 0.1 a/o percent to about 5 a/o percent manganese and from about 95 a/o percent to about 99.9 a/o percent silver.

[0062] In yet another embodiment of the present invention, the silver-based binary manganese alloy system as mentioned above is further alloyed with a third metal. The third metal may include cadmium, nickel, lithium and mixtures thereof. If one or a mixture of these metals replaces a portion of the silver in the alloy, the corrosion resistance of the resultant thin film will likely increase; however, the reflectivity will also likely drop. In relation to the amount of silver that is present in the above binary alloy systems, the amount of cadmium may be range from about 0.01 a/o percent to about 20 a/o percent of the alloy of the amount of silver present, the amount of nickel may range from between about 0.01 a/o percent to about 5.0 a/o percent of the amount of silver present, and the amount of lithium may range from about 0.01 a/o percent to about 10.0 a/o percent of the amount of silver present.

[0063] In still another embodiment of the present invention, the silver-based manganese alloy system as mentioned above is further alloyed with a precious metal such as gold, rhodium, copper, ruthenium, osmium, iridium, platinum, palladium, and mixtures thereof, which may be added to the above binary alloys with the preferable range of precious metal to be about 0.01 a/o to 5.0 a/o percent of the amount of silver present. In addition to the precious metals, the above alloys may also be alloyed with a metal such as titanium, indium, chromium, germanium, tin, antimony, gallium, silicon, boron, zirconium, molybdenum, and mixtures thereof. In relation to the amount of silver that is present in the above silver alloy system, the amount of the latter metal(s) that may be preferably added ranges from about 0.01 a/o percent to about 5.0 a/o percent of the amount of silver present.

[0064] In still another embodiment, the silver is alloyed with a comparatively small amount of germanium. In this embodiment, the relationship between the amounts of germanium and silver ranges from about 0.01 a/o percent to about 3.0 a/o percent germanium and from about 97.0 a/o percent to about 99.99 a/o percent silver. But preferably in respect to each metal, the alloy has from about 0.1 a/o percent to about 1.5 a/o percent germanium and from about 98.5 a/o percent to about 99.9 a/o percent silver.

[0065] In yet another embodiment of the present invention, the silver-based germanium alloy system as mentioned above is further alloyed with a third metal. The third metal may include manganese or aluminum. If one or a mixture of these metals replaces a portion of the silver in the alloy, the corrosion resistance of the resultant thin film will likely increase; however, the reflectivity will also likely drop. In relation to the amount of silver that is present in the above binary alloy system, the amount of manganese may be range from about 0.01 a/o percent to about 7.5 a/o percent of the amount of silver present and the amount of aluminum may range from between about 0.01 a/o percent to about 5.0 a/o percent of the amount of silver present.

[0066] In still another embodiment of the present invention, the silver-based germanium alloy system as mentioned above is further alloyed with a precious metal such as gold, rhodium, copper, ruthenium, osmium, iridium, platinum, palladium, and mixtures thereof, which may be added to the above binary alloys with the preferable range of precious metal to be about 0.01 a/o to 5.0 a/o percent of the amount of silver present. In addition to the precious metals, the above alloys may also be alloyed with a metal such as zinc, cadmium, lithium, nickel, titanium, zirconium, indium, chromium, tin, antimony, gallium, silicon, boron, molybdenum, and mixtures thereof. In relation to the amount of silver that is present in the above silver alloy system, the amount of these metals that may be preferably added ranges from about 0.01 a/o percent to about 5.0 a/o percent of the amount of silver present.

[0067] In still another embodiment, the silver is alloyed with a comparatively small amount of both copper and manganese. In this embodiment, the relationship between the amounts of copper, manganese and silver ranges from about 0.01 a/o percent to about 10 a/o percent copper, from about 0.01 a/o percent to about 7.5 a/o percent manganese, and from about 82.5 a/o percent to about 99.98 a/o percent silver. But preferably in respect to each metal, the alloy has

from about 0.1 a/o percent to about 5.0 a/o percent copper, from about 0.1 a/o percent to about 3.0 a/o percent manganese, and from about 92.0 a/o percent to about 99.8 a/o percent silver.

[0068] In yet another embodiment of the present invention, the silver-based copper-manganese alloy system as mentioned above is further alloyed a fourth metal. The fourth metal such as aluminum, titanium, zirconium, nickel, indium, chromium, germanium, tin, antimony, gallium, silicon, boron, molybdenum, and mixtures thereof. In relation to the amount of silver that is present in the above silver alloy system, the amount of fourth metal that may be preferably added ranges from about 0.01 a/o percent to about 5.0 a/o percent of the amount of silver present.

[0069] The optical properties of these silver alloys as thin film in the thickness of 8 to 12 nanometers for the semi reflective layer of DVD-9 dual, layer discs are illustrated in Table I in the following. As mentioned in U.S. Pat. No. 5,464,619 assigned to Matsushita Electric and U.S. Pat. No. 5,726,970 assigned to Sony that in a dual layer optical disc structure as indicated in FIG. 3 and in Table I, the relationship between the reflectivity of Layer "0" or 216 in FIG. 3 as R_0 , the reflectivity of Layer "1" or 220 measured from outside the disc in FIG. 3 as R_1 , and the transmission of Layer "0" as T_0 is $R_0=R_1T_0^2$ where R_1 is the reflectivity of Layer "1" itself. When the layer "0" thickness is optimized for balanced signal and reflectivity, and Layer "1" is an conventional aluminum alloy at 50 to 60 nanometers, the balanced reflectivity of various silver alloys is shown in Table I where R is the reflectivity of the thin film achievable at 60 nanometer or higher in thickness at 650 nanometer wavelength if used as the Layer "1" or the high reflectivity layer of DVD-9 or any other high reflectivity application of optical information storage medium. All compositions in the table are in atomic percent.

TABLE I

Balance of reflectivity of Layer 0 and Layer 1 of DVD-9 dual layer disc for various silver alloy Layer 0 and typical aluminum alloy Layer 1.				
Composition	T_0	R_0	R_1	R
Ag-13.0% Zn	0.47	0.185	0.183	0.80
Ag-6.0% Zn	0.52	0.22	0.224	0.92
Ag-4.0% Zn	0.53	0.23	0.233	0.93
Ag-10.3% Cd	0.51	0.22	0.216	0.91
Ag-14.5% Li	0.53	0.23	0.232	0.93
Ag-4.3% Al	0.47	0.18	0.183	0.80
Ag-1.5% Al	0.53	0.23	0.234	0.93
Ag-2.0% Ni	0.54	0.241	0.241	0.94
Ag-1.0% Ni	0.545	0.247	0.246	0.95
Ag-3.1% Mn	0.51	0.216	0.214	0.91
Ag-1.5% Mn	0.54	0.243	0.242	0.94
Ag-0.4% Ti	0.49	0.198	0.197	0.88
Ag-1.0% Zr	0.52	0.229	0.224	0.93

[0070] In still another embodiment of the present invention, the sputtering target and the thin film on the optical information storage medium is a silver alloy with a comparatively small addition of aluminum as alloying elements. In this embodiment, the relationship between the amounts of silver and aluminum ranges from about 0.01 a/o percent to about 5.0 a/o percent aluminum and from about 95.0 a/o percent to about 99.99 a/o percent silver. But preferably

from about 0.1 a/o percent to about 3.0 a/o percent aluminum, and from about 97.0 a/o percent to about 99.9 a/o percent silver. This silver and aluminum binary alloy can be further alloyed with zinc, cadmium, lithium, manganese, nickel, titanium and zirconium or mixtures of these metals. In relation to the amount of silver that is present in the above silver and aluminum binary alloy, the amount of the above-identified metal that may be preferably added ranges from 0.01 a/o percent to about 5.0 a/o percent of the silver content.

[0071] For the convenience of the reader, the following are some combinations of silver alloys, where the alloying elements are identified by their periodic table symbols, which may be preferably alloyed with silver: Ag+Zn, or Ag=Cd, or Ag+Li, or Ag+Al, or Ag+Ni, or Ag+Mn, or Ag+Ti, or Ag+Zr, or Ag+Pd+Zn, or Ag+Pt+Zn, or Ag+Pd+Mn, or Ag+Pt+Mn, or Ag+Zn+Li, or Ag+Pt+Li, or Ag+Li+Mn, or Ag+Li+Al, or Ag+Ti+Zn, or Ag+Zr+Ni, or Ag+Al+Ti, or Ag+Pd+Ti or Ag+Pt+Ti, or Ag+Ni+Al, or Ag+Mn+Ti, or Ag+Zn+Zr, or Ag+Li+Zr, or Ag+Mn+Zn, or Ag+Mn+Cu, or Ag+Pd+Pt+Zn or Ag+Pd+Zn+Mn, or Ag+Zn+Mn+Li, or Ag+Cd+Mn+Li, or Ag+Pt+Zn+Li, or Ag+Al+Ni+Zn, or Ag+Al+Ni+Ti, or Ag+Zr+Ti+Cd, or Ag+Zr+Ni+Li, or Ag+Zr+Ni+Al, or Ag+Pt+Al+Ni, or Ag+Pd+Zn+Al, or Ag+Zr+Zn+Ti, or Ag+Ti+Ni+Al.

[0072] In another embodiment of the present invention, silver can be alloyed additionally with indium, chromium, nickel, germanium, tin, antimony, gallium, silicon, boron, zirconium, and molybdenum or mixture of these elements. In relation to the amount of silver that is present in the alloy systems, the amount of the above-identified elements that may be added ranges from about 0.01 a/o percent to about 5.0 a/o percent of the silver content. But more preferably, the amount of alloying elements added to silver may ranges from about 0.1 a/o percent to about 3.0 a/o percent. This is further illustrated in Table II for an optical information storage medium as presented in FIG. 3. All the optical property symbols in Table II have the same meaning as in Table I.

TABLE II

Balance of reflectivity of Layer 0 and Layer 1 of DVD-9 dual layer disc for various silver alloy Layer 0 and typical aluminum alloy Layer 1.				
Composition	T ₀	R ₀	R ₁	R
Ag-2.5% In	0.500	0.212	0.208	0.91
Ag-1.2% Cr	0.535	0.243	0.238	0.94
Ag-0.7% Ge	0.515	0.220	0.220	0.92
Ag-1.0% Sn	0.504	0.216	0.211	0.92
Ag-0.5% Sb	0.520	0.224	0.224	0.93
Ag-3.0% Ga	0.475	0.195	0.187	0.86
Ag-1.5% Si	0.490	0.202	0.199	0.90
Ag-1.2% B	0.513	0.247	0.218	0.92
Ag-0.8% Mo	0.515	0.220	0.218	0.92

[0073] It is well understood that the compositions listed in table I or Table II can also be used as the high reflectivity layer or layer 1 in a prerecorded dual layer optical disc structure such as DVD-9, DVD-14 or DVD-18, or in a tri-layer optical disc structure as in FIG. 4 or in a recordable optical disc such as DVD-R or in a rewritable optical disc such as DVD-RAM or DVD-RW or as the one illustrated in FIG. 5.

[0074] For the convenience of the reader, the following are some combination of silver alloys, where the alloying elements are identified by their periodic table symbols, which may be preferably alloyed with silver: Ag+In, or Ag+Cr, or Ag+Ge, or Ag+Sn, or Ag+Sb, or Ag+Ga, or Ag+Si, or Ag+B, or Ag+Mo, or Ag+In+Cr, or Ag+Cr+Ge, or Ag+Cr+Sn, or Ag+Cr+Sb, or Ag+Cr+Si, or Ag+Si+In, or Ag+Si+Sb, or Ag+Si+B, or Ag+Si+Mo, or Ag+Mo+In, or Ag+Mo+Sn, or Ag+Mo+B, or Ag+Mo+Sb, or Ag+Ge+B, or Ag+In+Cr+Ge, or Ag+Cr+Sn+Sb, or Ag+Ga+Si+Mo, or Ag+Cr+Si+Mo, or Ag+B+Mo+Cr, or Ag+In+Sb+B, or Ag+Cr+Si+B, Ag+Ga+Ge+Cr, or Ag+Si+Ge+Mo or Ag+Sb+Si+B, or Ag+Cr+Si+In, or Ag+Si+Cr+Sn.

[0075] The optical properties of a few of the ternary silver alloys of the present invention are further illustrated in Table III wherein the reflectivity and transmission as layer zero thin film in the thickness of about 8 to 12 nm in a DVD-9 dual layer disc construction are shown. The meaning of each symbol is the same as in Table I.

TABLE III

Balance of reflectivity of Layer 0 and Layer 1 of DVD-9 dual layer disc for various ternary silver alloy layer 0 and typical aluminum alloy Layer 1.				
Composition	T ₀	R ₀	R ₁	R
Ag-1.2% Pd-1.4% Zn	0.54	0.245	0.242	0.95
Ag-0.8% Cu-1.5% Ni	0.535	0.240	0.238	0.94
Ag-1.5% Al-1.0% Mn 0.50	0.213	0.208	0.91	
Ag-1.0% Cu-0.3% Ti	0.50	0.210	0.207	0.90
Ag-1.2% Al-1.3% Zn	0.53	0.224	0.233	0.93
Ag-1.0% Ge-0.7% Al	0.49	0.203	0.201	0.89
Ag-1.2% Sb-0.3% Li	0.47	0.187	0.183	0.83

[0076] In still another embodiment of the current invention, the sputtering target and the thin film on the optical information storage medium is a silver alloy with a comparatively small addition of copper as an alloying element in conjunction with other alloying elements selected from the group consisting of aluminum, nickel, manganese, titanium, zirconium, indium, chromium, germanium, tin, antimony, gallium, silicon, boron, molybdenum and mixtures thereof. In this embodiment, the relationship between the amounts of silver and copper ranges from about 0.01 a/o percent to about 5.0 a/o percent copper and from about 95.0 a/o percent to about 99.99 a/o percent silver. But preferably from about 0.1 a/o percent to about 3.0 a/o percent copper, and from about 97.0 a/o percent to about 99.9 a/o percent silver. In relationship to the amount of silver that is present in the alloy system, the amount of the above-identified elements that may be added ranges from 0.01 a/o percent to about 5.0% of the silver content. But more preferably, the amount of alloying elements added to silver may ranges from about 0.1 a/o percent to about 3.0 a/o percent. As data presented in Table I, II and III indicated, if the individual alloy addition to silver is more than 5.0 a/o percent, the balanced reflectivity between layer zero and layer one in the DVD-9 dual layer disc structure is likely to be lower than the DVD specification of 18 percent, therefore not composition with utility.

[0077] Having presented the preceding compositions for the thin film materials, it is important to recognize that both the manufacturing process of the sputtering target and the

process to deposit the target material into a thin film play important roles in determining the final properties of the film. To this end, a preferred method of making the sputtering target will now be described. In general, vacuum melting and casting of the alloys or melting and casting under protective atmosphere, are preferred to minimize the introduction of other unwanted impurities.

[0078] Afterwards, the as-cast ingot should undergo a cold working process to break down the segregation and the nonuniform as-cast microstructure. One preferred method is cold forging or cold uniaxial compression with more than 50 percent of size reduction, followed by annealing to recrystallize the deformed material into fine equi-axed grain structure with preferred texture of $\langle 1,1,0 \rangle$ orientation. This texture promotes directional sputtering in a sputtering apparatus so that more of the atoms from the sputtering target will be deposited onto the disc substrates for more efficient use of the target material.

[0079] Alternatively, a cold multi-directional rolling process of more than 50 percent size reduction can be employed, followed by annealing to promote a random oriented microstructure in the target and finally by machining to the final shape and size suitable for a given sputtering apparatus. This target with random crystal orientation will lead to a more random ejection of atoms from the target during sputtering and a more uniform thickness distribution in the disc substrate.

[0080] Depending on different discs' optical and other system requirements, either a cold forging or a cold multi-directional rolling process can be employed in the target manufacturing process to optimize the optical and other performance requirements of the thin film for a given application.

[0081] The alloys of this invention can be deposited in the well-known manners described earlier, those being sputtering, thermal evaporation or physical vapor deposition, and possibly electrolytic or electroless plating processes. Depending on the method of application, the alloy thin film's reflectivity could vary. Any application method that adds impurities to or changes the surface morphology of the thin film layer on the disc could conceivably lower the reflectivity of the layer. But to the first order of approximation, the reflectivity of the thin film layer on the optical disc is primarily determined by the starting material of the sputtering target, evaporation source material, or the purity and composition of the electrolytic and electroless plating chemicals.

[0082] It should be understood that the reflective layer of this invention can be used for future generations of optical discs that use a reading laser of a shorter wavelength, for example, when the reading laser's wavelength is shorter than 650 nanometers.

[0083] It should also be understood that, if the reflective film is reduced to a thickness of approximately 5 to 20 nanometers, a semi-reflective film layer can be formed from the alloys of this invention that have sufficient light transmittance for use in DVD dual-layer applications.

V. EXAMPLES

Example 1

[0084] An alloy composition of silver with approximately 1.2 atomic percent chromium and approximately 1.0 atomic

percent zinc will have a reflectivity of approximately 94 to 95 percent at the wavelength of 800 nanometers and a reflectivity of approximately 93 to 94 percent at the wavelength of 650 nanometers and a reflectivity of approximately 86 to 88 percent at the wavelength of 400 nanometers with the film thickness at about 60 to 100 nanometers.

Example 2

[0085] A silver-rich alloy with 1.5 a/o percent of manganese, 0.8 a/o percent of copper will have a reflectivity of approximately 94 to 95 percent at 650 nanometers wavelength. If the thickness of the thin film is reduced to the 8 to 12 nanometers range, the reflectivity will be reduced to the 18 to 30 percent range applicable for DVD-9's semi-reflective layer. Adding a low concentration of deoxidizer such as lithium can further simplify the manufacturing process of the starting material of the thin film. As silver has a tendency to dissolve some oxygen in the solid state which tends to lower the reflectivity of the alloy, the added lithium will react with the oxygen and lessen the degree of oxygen's impact to reflectivity. The desirable range of lithium is in the approximate range of 0.01 percent to 5.0 atomic percent, with the preferred range from about 0.1 to 1.0 a/o percent.

Example 3

[0086] A silver based alloy with about 0.5 a/o percent of nickel and about 0.5 a/o percent of zinc will have a reflectivity of approximately 95 percent at the wavelength of about 650 nanometers at a thickness of 60 to 70 nanometers and is suitable for any high reflectivity application in an optical information storage medium.

Example 4

[0087] Another silver based alloy sputtering target with the composition of about 1.0 a/o percent manganese, 0.3 a/o percent titanium and the balance silver is employed to produce the semi-reflective layer of the DVD-9 dual layer disc with the following procedure: On top of a transparent polycarbonate half disc of approximately 0.6 millimeter thickness and 12 centimeter in diameter with information pits injection molded from a suitable stamper, a semi-reflective thin film or layer "zero" of silver based alloy approximately 10 to 11 nanometers in thickness is deposited or coated onto the half disc using the sputtering target of the above-mentioned composition in a magnetron sputtering machine. On top of another transparent polycarbonate half disc of approximately 0.6 millimeter thickness with information pits injection molded from another suitable stamper, a high reflectivity thin film or layer "one" of aluminum based alloy approximately 55 nanometers in thickness is deposited using a suitable aluminum sputtering target in another sputtering machine. These two half discs are then spin-coated with suitable liquid organic resins separately, bonded together with layer "zero" and layer "one" facing each other and the resin is cured with ultraviolet light. The distance between the layer "zero" and the layer "one" is kept at about 55 ± 5 microns within the disc. The reflectivity of the two information layers is measured from the same side of the disc and found to be about the same at 21 percent for the 650 nanometers wavelength laser light. Electronic signal such as jitter and PI error are measured and found to be within the published DVD specifications. Subsequently, an accelerated aging test at 80 degrees C. and 85 percent relative humidity

for 4 days is conducted on the disc. Afterwards, the reflectivity and the electronic signals are measured again and no significant changes were observed as compared to the same measurements before the aging test.

Example 5

[0088] A silver alloy sputtering target with the composition in atomic percent of about 0.2 percent lithium, 1.0 percent manganese, 0.3 percent germanium and the balance silver is employed to produce the semi-reflective layer of the DVD-9 dual layer disc. The procedure used to make the discs is the same as in example 4 above. The reflectivity of the two information layer in the finished disc is measured from the same side of the disc and found to be about the same at 22.5 percent for the 650 nanometers wavelength laser light. Electronic signals such as jitter and PI error are also measured and found to be within the published DVD specifications. Subsequently, an accelerated aging test at 70 degrees C. and 50 percent relative humidity for 96 hours is conducted on the disc. Afterwards, the reflectivity and the electronic signals are measured again and no significant changes are observed as compared to the same measurements before the aging test.

[0089] It is understood that the same silver alloy thin film in this example deposited on the disc in the thickness range from about 30 to about 200 nanometers range can serve the purpose of the high reflectivity layer such as Layer "one" in DVD-9, or Layer "two" in a tri-layer optical disc as in FIG. 4 or other high reflectivity application in a rewritable optical disc such as DVD-RW, DVD-RAM in a general structure as illustrated in FIG. 5 at 650 nanometers wavelength or any other future optical information storage medium played back at around 400 nanometers wavelength.

Example 6

[0090] A silver based alloy sputtering target with the composition in a/o % of approximately 1.3% manganese, 0.7% aluminum, and the balance silver is used to produce the reflective layer of a DVD-R disc, another type of recordable disc according to FIG. 2 with the following procedure: On top of a transparent polycarbonate half disc of about 0.6 mm thickness and 12 cm in diameter with pre-grooves suitable for DVD-R injection molded from a suitable stamper, a cyanine based recording dye is spin-coated on the substrate, dried, and subsequently a reflective layer of silver based alloy approximately 60 nm in thickness is deposited or coated on the recording dye using the sputtering target of the above mentioned composition in a magnetron sputtering machine. Afterwards, this half disc is bonded to another 0.6 mm thickness half disc by a UV cured resin. Information is recorded onto the disc in a DVD-R recorder and the quality of the electronic signal is measured. Then the disc is subjected to an accelerated aging test at 80 degrees C. and 85% RH for 96 hours. Afterwards, the reflectivity and the electronic signal is measured again and no significant changes are observed as compared to the same measurements before aging test.

Example 7

[0091] A process to make the sputtering target with the composition as indicated in example 6 will be described hereafter. Suitable charges of silver, manganese and alumi-

num are put into the crucible of a suitable vacuum induction furnace. The vacuum furnace is pumped down to vacuum pressure of approximately 1 milli-torr and then induction heating is used to heat the charge. While the charge is heating up and the out gassing is finished, the furnace can be back filled with argon gas to a pressure of about 0.2 to 0.4 atmosphere. Casting of the liquid melt can be accomplished at a temperature of approximately 10% above the melting point of the charge. The graphite crucible holding the melt can be equipped with a graphite stopper at the bottom of the crucible. Pouring of the molten metal into individual molds of each sputtering target can be accomplished by opening and closing of the graphite stopper and synchronizing this action with mechanically bringing each mold into position just underneath the melting crucible so that the proper amount of melt can be poured and cast into each target mold by gravity. Afterwards, additional argon flow into the vacuum furnace can be introduced to cool and quench the casting to lower temperature. Subsequently, a cold or warm multi-directional rolling process with more than 50% thickness reduction can be used to break up any nonuniform casting microstructure. Then final anneal is done at 550 to 600 degrees C. in a protective atmosphere for 15 to 30 minutes. After machining the target piece into the right shape and size, cleaning in detergent and properly dried, the finished sputtering target is ready to be put into a magnetron sputtering apparatus to coat optical discs. The approximate sputtering parameters to make the semi-reflective layer of an ultra high density optical disc with playback laser wavelength at 400 nanometers as mentioned in example 9 are 1 kilowatt of sputtering power, 1 second of sputtering time at an argon partial pressure of 1 to 3 milli-torr for a deposition rate of 10 nanometers per second with the target to disc distance of approximately 4 to 6 centimeters. The high reflectivity layer can be made with about the same sputtering parameters as the semi-reflective layer except the sputtering power needs to be increased to 4 to 5 kilowatts to deposit the high reflectivity layer using the same sputtering target and sputtering apparatus. Thus a 5 inch diameter ultra high density read-only optical disc can be made in this manner with user storage capacity of about 12 to 15 giga bytes per side. A dual layer disc with the construction as shown in FIG. 3. can store approximately 24 to 30 giga bytes of information, enough for a full length motion picture in the high-definition digital television format.

Example 8

[0092] A silver alloy sputtering target having the composition in a/o %: Pd, 1.2%, Zn, 1.4% and balance silver was used to produce a dual layer optical information storage medium as depicted in FIG. 3. Thin film about 10 nanometers thickness of this silver alloy was deposited by a magnetron sputtering machine on a suitable polycarbonate substrate. The feasibility of using the same silver alloy thin film for both the reflective layer and the semi-reflective layer of a dual layer ultra high density read-only optical disc with a playback laser wavelength at 400 nanometers is investigated. As indicated in FIG. 3, the indices of refraction n of the transparent substrate 214, the semi-reflective layer 216, the spacer layer 218 and the high reflectivity layer are 1.605, 0.035, 1.52, 0.035 respectively. The extinction coefficient k for the semi-reflective layer and the high reflectivity layer is 2.0. Calculation shows that with a thickness of 24 nm, the semi-reflective layer will have a reflectivity R_0 of 0.242 and

a transmission T_0 of 0.600 in the disc at 400 nm wavelength. With a thickness of 55 nm, the high reflectivity layer will have a reflectivity R_1 of 0.685. The reflectivity of the high reflectivity layer measured from outside the disc through the semi-reflective layer will be $R_0=R_1T_0^2$ or 0.247. In other words, to the detector outside the disc, the reflectivity from both the semi-reflective layer and the high reflectivity layer will be approximately the same. This fulfills one of the important requirements of a dual layered optical information storage medium that the reflectivity from these 2 layers of information should be approximately equal and the relationship between the optical properties of these two layers is $R_0=R_1T_0^2$.

Example 9

[0093] The same silver alloy in example 8 can also be used as the high reflectivity layer and the two semi-reflective layers in a tri-layer optical information storage medium as depicted in FIG. 4 at 400 nm playback laser wavelength. Calculations show that for a thickness of 16 nm for the first semi-reflective layer 316, a thickness of 24 nm for the second semi-reflective layer 320 and a thickness of 50 nm for the high reflectivity layer 324 in FIG. 4, the reflectivity measured at the detector 332 will be 0.132, 0.137, 0.131 respectively from the three layers. And approximately the same reflectivity from all three layers can be achieved. Thus balance of reflectivity from three information layers using the same silver alloy can be achieved and one sputtering machine and one silver alloy sputtering target can be used to manufacture all three layers of an ultra high density tri-layer optical information storage medium with playback laser wavelength at 400 nm in a production environment. It will be obvious that the aluminum alloys can also be used for the high reflectivity layer of this tri-layer medium

Example 10

[0094] A silver alloy sputtering target having the composition in a/o % : Au, 2.6%; Pd, 1.1%; Pt, 0.3%; Cu, 0.4% and balance silver was used to produce the high reflectivity layer in a rewritable phase change disc structure or DVD+RW as shown in FIG. 5. On the 0.6 mm thickness polycarbonate substrate with continuous spiral tracks of grooves and lands injection molded from a suitable stamper, successive layers of ZnO.SiO₂, Ag—In—Sb—Te, and ZnO.SiO₂ with suitable thickness are coated on the substrate. Afterwards the sputtering target of the above composition is used in a magnetron sputtering apparatus to deposit about 150 nm thickness of the silver alloy film on top of the ZnO.SiO₂ film. Subsequently, the half disc is bonded with a suitable adhesive to the other 0.6 mm thickness half disc with the same construction as mentioned above to form the complete disc. Repeated record and erase cycles are performed in a suitable DVD+RW drive. The disc meets the performance requirements imposed on the recording medium. The disc further goes through an accelerated environmental test at 80 degrees C., 85% relative humidity for 10 days. Afterwards, the disc performance is checked again, no significant change in the disc property is observed as compared to the disc performance before the environmental test.

Example 11

[0095] A silver alloy sputtering target having the composition in a/o % : Cu, 1.0%; Ag, 99.0% was used to produce

the highly reflective layer in a rewritable phase change disc structure or "DVR" as shown in FIG. 6 except that between the dielectric layer 520 and the highly reflective-layer 522, there is an interface layer of SiC (not shown). Compared to Example 10, layers in the disc in this example are deposited in the reverse order. The transparent substrate 524 was made of polycarbonate and injection molded from a suitable stamper, then the silver alloy reflective layer was deposited on the transparent substrate using the above-mentioned sputtering target in a magnetron sputtering apparatus. The dielectric layer 520 (preferably ZnO.SiO₂), the recording layer 518 (preferably Ag—In—Sb—Te), another dielectric layer 516 (preferably ZnO.SiO₂) and the interface layer (preferably SiC) were then vacuum coated in sequence. Lastly, the disc was coated by a covering layer of UV cured resin 514 10 to 15 microns in thickness. The performance of the disc was verified with a DVR type of player with 400 nm wavelength laser beam recording and play back system. Repeated record and erase cycles were conducted satisfactorily. Afterwards, the disc was further subjected to an accelerated environmental test condition of about 80 degrees C. and 85% relative humidity for 4 days. The performance of the disc was again checked and verified. No significant degradation of the disc property was observed.

[0096] While the invention has been illustrated and described in detail, this is to be considered as illustrative and not restrictive of the patent rights. The reader should understand that only the preferred embodiments have been presented and all changes and modifications that come within the spirit of the invention are included if the following claims or the legal equivalent of these claims describes them.

I claim:

1. An optical storage medium, comprising:
 - a first layer having a pattern of features in at least one major surface; and
 - a first coating adjacent the first layer, the first coating including a first metal alloy; wherein the first metal alloy includes silver and zinc; and wherein the relationship between the amounts of silver and zinc is defined by Ag_xZn_y , where $0.85 < x < 0.9999$ and $0.0001 < y < 0.15$.
2. The medium of claim 1, and wherein $0.001 < y < 0.10$.
3. The medium of claim 1 wherein said first coating directly contacts said first metal alloy.
4. The medium of claim 1, further including:
 - a second layer having a pattern of features in at least one major surface; and
 - a second coating adjacent the second layer.
5. The medium of claim 1 further including:
 - a second layer having a pattern of features in at least one major surface, the second layer including a dielectric material;
 - a third layer having a pattern of features in at least one major surface, the third layer including an optically re-recordable material; and
 - a fourth layer having a pattern of features in at least one major surface, the fourth layer including a dielectric material.

6. The medium of claim 5 wherein the optically recordable material is a phase-changeable material.

7. The medium of claim 6 wherein the optically recordable material further comprises a phase changeable material selected from the group consisting of Ge—Sb—Te, As—In—Sb—Te, Cr—Ge—Sb—Te, As—Te—Ge, Te—Ge—Sn, Te—Ge—Sn—O, Te—Se, Sn—Te—Se, Te—Ge—Sn—Au, Ge—Sb—Te, Sb—Te—Se, In—Se—Tl, In—Sb, In—Sb—Se, In—Se—Tl—Co, and Si—Te—Sn.

8. The medium of claim 5 wherein the optically recordable material is a magneto-optic material.

9. The medium of claim 8 wherein the optically recordable material further comprises a magneto-optic material selected from the group consisting of Tb—Fe—Co and Gd—Tb—Fe.

10. The medium of claim 1, wherein the first metal alloy includes cadmium present from about 0.01 a/o percent to about 20.0 a/o percent of the amount of silver present.

11. The medium of claim 1, wherein the first metal alloy includes lithium present from about 0.01 a/o percent to about 10.0 a/o percent of the amount of silver present.

12. The medium of claim 1, wherein the first metal alloy includes manganese present from about 0.01 a/o percent to about 7.5 a/o percent of the amount of silver present.

13. The medium of claim 1, wherein the first metal alloy includes a metal selected from the group consisting of gold, rhodium, copper, ruthenium, osmium, iridium, platinum and palladium and mixtures thereof, and wherein the metal is present from about 0.01 a/o percent to about 5.0 a/o percent of the amount of silver present.

14. The medium of claim 1, and wherein the first metal alloy includes a metal selected from the group consisting of titanium, nickel, indium, chromium, germanium, tin, antimony, gallium, silicon, boron, zirconium, molybdenum and mixtures thereof, and wherein the metal is present from about 0.01 a/o percent to about 5.0 a/o percent of the amount of silver present.

15. An optical storage medium, comprising:

a first layer having a pattern of features in at least one major surface; and

a first coating adjacent the first layer, the first coating including a first metal alloy; wherein the first metal alloy includes silver and aluminum; and wherein the relationship between the amounts of silver and aluminum is defined by Ag_xAl_z where $0.95 < x < 0.9999$ and $0.0001 < z < 0.05$.

16. The medium of claim 15, and wherein $0.001 \leq z \leq 0.03$.

17. The medium of claim 15 wherein said first coating directly contacts said first metal alloy.

18. The medium of claim 15, further including:

a second layer having a pattern of features in at least one major surface; and

a second coating adjacent the second layer.

19. The medium of claim 15 further comprising:

a second layer having a pattern of features in at least one major surface, the second layer including a dielectric material;

a third layer having a pattern of features in at least one major surface, the third layer including an optically re-recordable material; and

a fourth layer having a pattern of features in at least one major surface, the fourth layer including a dielectric material.

20. The medium of claim 19 wherein the optically recordable material is a phase-changeable material.

21. The medium of claim 20 wherein the optically recordable material further comprises a phase changeable material selected from the group consisting of Ge—Sb—Te, As—In—Sb—Te, Cr—Ge—Sb—Te, As—Te—Ge, Te—Ge—Sn, Te—Ge—Sn—O, Te—Se, Sn—Te—Se, Te—Ge—Sn—Au, Ge—Sb—Te, Sb—Te—Se, In—Se—Tl, In—Sb, In—Sb—Se, In—Se—Tl—Co, and Si—Te—Sn.

22. The medium of claim 19 wherein the optically recordable material is a magneto-optic material.

23. The medium of claim 22 wherein the optically recordable material further comprises a magneto-optic material selected from the group consisting of Tb—Fe—Co and Gd—Tb—Fe.

24. The medium of claim 15, wherein the first metal alloy includes manganese present from about 0.01 a/o percent to about 7.5 a/o percent of the amount of silver present.

25. The medium of claim 15, wherein the first metal alloy includes cadmium present from about 0.01 a/o percent to about 20.0 a/o percent of the amount of silver present.

26. The medium of claim 15, wherein the first metal alloy includes a metal selected from the group consisting of lithium, zinc and mixtures thereof, and wherein the metal is present from about 0.1 a/o percent to about 15.0 a/o percent of the amount of silver present.

27. The medium of claim 15, wherein the first metal alloy includes a metal selected from the group consisting of gold, rhodium, copper, ruthenium, osmium, iridium, platinum, palladium and mixtures thereof, and wherein the metal is present from about 0.01 a/o percent to about 5.0 a/o percent of the amount of silver present.

28. The medium of claim 15, and wherein the first metal alloy includes a metal selected from the group consisting of titanium, nickel, indium, chromium, germanium, tin, antimony, gallium, silicon, boron, zirconium and molybdenum and mixtures thereof, and wherein the metal is present from about 0.01 a/o percent to about 5.0 a/o percent of the amount of silver present.

29. An optical storage medium, comprising:

a first layer having a pattern of features in at least one major surface; and

a first coating adjacent the first layer, the first coating including a first metal alloy; wherein the first metal alloy includes silver, zinc and aluminum; and wherein the relationship between the amounts of silver, zinc and aluminum is defined by $Ag_xZn_yAl_z$ where $0.80 < x < 0.998$, $0.001 < y < 0.15$, and $0.001 < z < 0.05$.

30. The medium of claim 29, and wherein $0.001 \leq y \leq 0.05$ and $0.001 \leq z \leq 0.03$.

31. The medium of claim 29 wherein said first coating directly contacts said first metal alloy.

32. The medium of claim 29, further including:

a second layer having a pattern of features in at least one major surface; and

a second coating adjacent the second layer.

- 33.** The medium of claim 29 further including:
- a second layer having a pattern of features in at least one major surface, the second layer including a dielectric material;
 - a third layer having a pattern of features in at least one major surface, the third layer including an optically re-recordable material;
 - a fourth layer having a pattern of features in at least one major surface, the fourth layer including a dielectric material.
- 34.** The medium of claim 33 wherein the optically re-recordable material is a phase-changeable material.
- 35.** The medium of claim 34 wherein the optically re-recordable material further comprises a phase changeable material selected from the group consisting of Ge—Sb—Te, As—In—Sb—Te, Cr—Ge—Sb—Te, As—Te—Ge, Te—Ge—Sn, Te—Ge—Sn—O, Te—Se, Sn—Te—Se, Te—Ge—Sn—Au, Ge—Sb—Te, Sb—Te—Se, In—Se—Tl, In—Sb, In—Sb—Se, In—Se—Tl—Co, and Si—Te—Sn.
- 36.** The medium of claim 33 wherein the optically re-recordable material is a magneto-optic material.
- 37.** The medium of claim 36 wherein the optically re-recordable material further comprises a magneto-optic material selected from the group consisting of Tb—Fe—Co and Gd—Tb—Fe.
- 38.** The medium of claim 29, wherein the first metal alloy includes manganese present from about 0.01 a/o percent to about 7.5 a/o percent of the amount of silver present.
- 39.** The medium of claim 38, wherein the manganese is present from about 0.01 a/o percent to about 5.0 a/o percent of the amount of silver present.
- 40.** The medium of claim 29, wherein the first metal alloy includes nickel present from about 0.01 a/o percent to about 5.0 a/o percent of the amount of silver present.
- 41.** The medium of claim 40, wherein the nickel is present from about 0.01 a/o percent to about 3.0 a/o percent of the amount of silver present.
- 42.** The medium of claim 29, and wherein the first metal alloy includes a metal selected from the group consisting of ruthenium, copper, rhodium, osmium, iridium, gold, palladium and platinum and mixtures thereof, and wherein the metal is present from about 0.1 a/o percent to about 5.0 a/o percent of the amount of silver present.
- 43.** An optical storage medium, comprising:
- a first layer having a pattern of features in at least one major surface; and
 - a first coating adjacent the first layer, the first coating including a first metal alloy; the first metal alloy including silver and manganese wherein the relationship between the amounts of silver and manganese is defined by Ag_xMn_t where $0.925 < x < 0.9999$ and $0.0001 < t < 0.075$.
- 44.** The medium of claim 43, and wherein $0.001 \leq t \leq 0.05$.
- 45.** The medium of claim 43 wherein said first coating directly contacts said first metal alloy.
- 46.** The medium of claim 43, further including:
- a second layer having a pattern of features in at least one major surface; and
 - a second coating adjacent the second layer.
- 47.** The medium of claim 43 further comprising:
- a second layer having a pattern of features in at least one major surface, the second layer including a dielectric material;
 - a third layer having a pattern of features in at least one major surface, the third layer including an optically re-recordable material; and
 - a fourth layer having a pattern of features in at least one major surface, the fourth layer including a dielectric material.
- 48.** The medium of claim 47 wherein the optically re-recordable material is a phase-changeable material.
- 49.** The medium of claim 48 wherein the optically re-recordable material further comprises a phase changeable material selected from the group consisting of Ge—Sb—Te, As—In—Sb—Te, Cr—Ge—Sb—Te, As—Te—Ge, Te—Ge—Sn, Te—Ge—Sn—O, Te—Se, Sn—Te—Se, Te—Ge—Sn—Au, Ge—Sb—Te, Sb—Te—Se, In—Se—Tl, In—Sb, In—Sb—Se, In—Se—Tl—Co, and Si—Te—Sn.
- 50.** The medium of claim 47 wherein the optically re-recordable material is a magneto-optic material.
- 51.** The medium of claim 50 wherein the optically re-recordable material further comprises a magneto-optic material selected from the group consisting of Tb—Fe—Co and Gd—Tb—Fe.
- 52.** The medium of claim 43, wherein the first metal alloy includes cadmium present from about 0.01 a/o percent to about 20.0 a/o percent of the amount of silver present.
- 53.** The medium of claim 43, wherein the first metal alloy includes lithium present from about 0.01 a/o percent to about 10.0 a/o percent of the amount of silver present.
- 54.** The medium of claim 43, wherein the first metal alloy includes manganese present from about 0.01 a/o percent to about 5.0 a/o percent of the amount of silver present.
- 55.** The medium of claim 43 wherein the first metal alloy further comprises a metal selected from the group consisting of ruthenium, copper, rhodium, osmium, iridium, gold, palladium and platinum and mixtures thereof, and wherein the metal is present from about 0.01 a/o percent to about 5.0 a/o percent of the amount of silver present.
- 56.** The medium of claim 43 wherein the first metal alloy further comprises a metal selected from the group consisting of titanium, indium, chromium, germanium, tin, antimony, gallium, silicon, zirconium, boron, and molybdenum and mixtures thereof, and wherein the metal is present from about 0.1 a/o percent to about 5.0 a/o percent of the amount of silver present.
- 57.** An optical storage medium, comprising:
- a first layer having a pattern of features in at least one major surface; and
 - a first coating adjacent the first layer, the first coating including a first metal alloy; the first metal alloy including silver and germanium wherein the relationship between the amounts of silver and germanium is defined by Ag_xGe_q where $0.97 < x < 0.9999$ and $0.0001 < q < 0.03$.
- 58.** The medium of claim 57, and wherein $0.001 \leq q \leq 0.015$.
- 59.** The medium of claim 57 wherein said first coating directly contacts said first metal alloy.
- 60.** The medium of claim 57, further including:
- a second layer having a pattern of features in at least one major surface; and
 - a second coating adjacent the second layer.

- 61.** The medium of claim 57 further comprising:
- a second layer adjacent having a pattern of features in at least one major surface, the second layer including a dielectric material;
 - a third layer having a pattern of features in at least one major surface, the third layer including an optically re-recordable material; and
 - a fourth layer having a pattern of features in at least one major surface, the fourth layer including a dielectric material.
- 62.** The medium of claim 61 wherein the optically re-recordable material is a phase-changeable material.
- 63.** The medium of claim 62 wherein the optically re-recordable material further comprises a phase changeable material selected from the group consisting of Ge—Sb—Te, As—In—Sb—Te, Cr—Ge—Sb—Te, As—Te—Ge, Te—Ge—Sn, Te—Ge—Sn—O, Te—Se, Sn—Te—Se, Te—Ge—Sn—Au, Ge—Sb—Te, Sb—Te—Se, In—Se—Tl, In—Sb, In—Sb—Se, In—Se—Tl—Co, and Si—Te—Sn.
- 64.** The medium of claim 61 wherein the optically re-recordable material is a magneto-optic material.
- 65.** The medium of claim 64 wherein the optically re-recordable material further comprises a magneto-optic material selected from the group consisting of Tb—Fe—Co and Gd—Tb—Fe.
- 66.** The medium of claim 57 wherein the first metal alloy further includes manganese present from about 0.01 a/o percent to about 7.5 a/o percent of the amount of silver present.
- 67.** The medium of claim 57 wherein the first metal alloy further includes aluminum present from about 0.01 a/o percent to about 5.0 a/o percent of the amount of silver present.
- 68.** The medium of claim 57 wherein the first metal alloy further comprises a metal selected from the group consisting of ruthenium, copper, rhodium, osmium, iridium, gold, palladium and platinum and mixtures thereof, and wherein the metal is present from about 0.1 a/o percent to about 5.0 a/o percent of the amount of silver present.
- 69.** The medium of claim 57 wherein the first metal alloy further comprises a metal selected from the group consisting of zinc, cadmium, lithium, nickel, titanium, zirconium, indium, chromium, tin, antimony, gallium, silicon, boron, and molybdenum and mixtures thereof, and wherein the metal is present from about 0.01 a/o percent to about 5.0 a/o percent of the amount of silver present.
- 70.** An optical storage medium, comprising:
- a first layer having a pattern of features in at least one major surface; and
 - a first coating adjacent the first layer, the first coating including a first metal alloy; wherein the first metal alloy includes silver, copper and manganese; and wherein the relationship between the amounts of silver, copper and manganese is defined by Ag_xCu_pMn , where $0.825 < x < 0.9998$, $0.0001 < p < 0.10$, and $0.0001 < t < 0.075$.
- 71.** The medium of claim 70, and wherein $0.001 \leq p \leq 0.05$ and $0.001 \leq t \leq 0.03$.
- 72.** The medium of claim 70 wherein said first coating directly contacts said first metal alloy.
- 73.** The medium of claim 70, further including:
- a second layer having a pattern of features in at least one major surface; and
 - a second coating adjacent the second layer.
- 74.** The medium of claim 70 further comprising:
- a second layer: having a pattern of features in at least one major surface, the second layer including a dielectric material;
 - a third layer having a pattern of features in at least one major surface, the third layer including an optically re-recordable material;
 - a fourth layer having a pattern of features in at least one major surface, the fourth layer including a dielectric material.
- 75.** The medium of claim 74 wherein the optically re-recordable material is a phase-changeable material.
- 76.** The medium of claim 75 wherein the optically re-recordable material further comprises a phase changeable material selected from the group consisting of Ge—Sb—Te, As—In—Sb—Te, Cr—Ge—Sb—Te, As—Te—Ge, Te—Ge—Sn, Te—Ge—Sn—O, Te—Se, Sn—Te—Se, Te—Ge—Sn—Au, Ge—Sb—Te, Sb—Te—Se, In—Se—Tl, In—Sb, In—Sb—Se, In—Se—Tl—Co, and Si—Te—Sn.
- 77.** The medium of claim 74 wherein the optically re-recordable material is a magneto-optic material.
- 78.** The medium of claim 77 wherein the optically re-recordable material further comprises a magneto-optic material selected from the group consisting of Tb—Fe—Co and Gd—Tb—Fe.
- 79.** The medium of claim 70, wherein the first metal alloy further comprises a metal selected from the group consisting of aluminum, titanium, zirconium, nickel, indium, chromium, germanium, tin, antimony, gallium, silicon, boron, molybdenum, and mixtures thereof, and wherein the metal is present from about 0.01 a/o percent to about 5.0 a/o percent of the amount of silver present.

* * * * *