

E. G. JACKSON.
RAILWAY SWITCH.
APPLICATION FILED OCT. 15, 1910.

996,858.

Patented July 4, 1911.

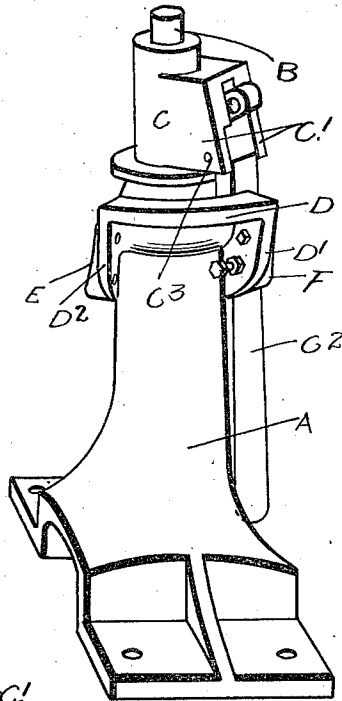

FIG. 1.

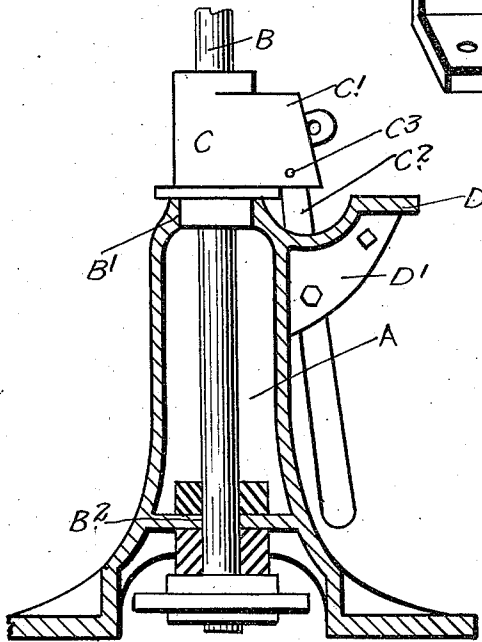

FIG. 2.

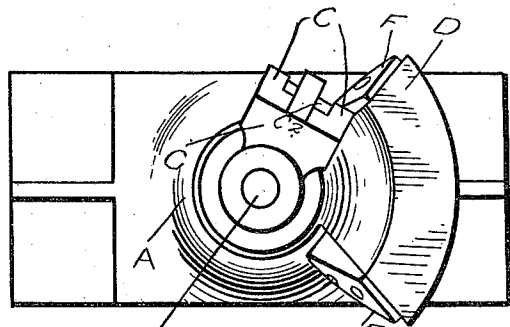

FIG. 3.

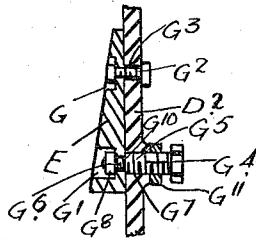

FIG. 4.

WITNESSES
J. M. Law,
J. Moore

INVENTOR,
E. G. Jackson
By Fred. B. Dellestrucchi

UNITED STATES PATENT OFFICE.

ERNEST GEORGE JACKSON, OF TORONTO, ONTARIO, CANADA.

RAILWAY-SWITCH.

996,858.

Specification of Letters Patent.

Patented July 4, 1911.

Application filed October 15, 1910. Serial No. 587,645.

To all whom it may concern:

Be it known that I, ERNEST GEORGE JACKSON, of the city of Toronto, in the county of York, in the Province of Ontario, Canada, have invented certain new and useful Improvements in Railway-Switches, of which the following is the specification.

My invention relates to improvements in railway switches and the object of the invention is to devise a simple device whereby the adjustment of the switch point may be accomplished by the operation of the switch stand lever so as to positively and automatically bring the switch point to a completely closed position and thus dispense with various means of adjustment in the switch itself, and it consists essentially of a bracket forming part of the switch stand and of segmental form, wedge blocks secured to each side of the bracket and adjustable means for securing the block to the bracket, whereby the wedge may be adjusted to different degrees of incline, as hereinafter more particularly described by the following specification.

Figure 1 is a general perspective view of a switch stand. Fig. 2 is a vertical sectional view through the switch stand. Fig. 3 is a plan view of the switch stand. Fig. 4 is an enlarged sectional detail of the means for adjustably connecting the wedge blocks to the segmental switch stand bracket.

In the drawings like letters of reference indicate corresponding parts in each figure.

"A" is a switch stand of usual form and provided with a vertically journaled mast "B" held in the usual manner in the vertical bearings "B¹" and "B²," as will be seen from the drawings. I only show the lower part of the mast the upper part to which the target is secured being broken away.

"C" is a block secured to the mast "B" and provided with the usual jaws "C¹" between which the operating lever "C²" is pivoted on pin "C³."

All the parts I have hitherto described are usual to the construction of switch stands and I therefore lay no claim to them. I will now describe the means by which the switch point is positively drawn into its two closed positions when the operating lever "C²" is thrown into its depressed position and which I claim to be new.

"D" is a bracket secured to or forming part of the switch stand. The bracket "D" is of segmental form and is provided with

depending wings "D¹" and "D²," forming the sides of the bracket.

"E" and "F" are wedge blocks provided with countersunk orifices "G" and "G¹," (see Fig. 4).

"G²" and "G⁴" are bolts extending through the countersunk orifices "G" of the blocks "E" and "F" and the orifices "G³" in the wings "D¹" "D²." It will, of course, be understood that the bolt "G²" extends through the countersunk orifices and is used to secure wedge after adjustment by bolt "G⁴."

"G⁴" is a bolt provided with a major portion "G⁵" and a minor threaded portion "G⁶." The major threaded portion "G⁵" is threaded into an orifice "G⁷" and a minor threaded portion "G⁶" extends loosely through the orifice "G¹" the end thereof being provided with a nut "G⁸" threaded thereon. It will be seen by referring to Fig. 4 of the drawing, that the wedge blocks "E" and "F" are held between the shoulder "G¹⁰" and the nut "G⁸." It will thus be seen that by turning the bolts "G⁴" in the orifice "G⁷" that the lower end of the blocks "E" and "F" may be adjusted inwardly or outwardly to increase or decrease the incline of the blocks.

"G¹¹" is a lock nut designed to lock the bolt "G⁵" in place after it has been adjusted.

It will be readily seen from this description that when the lever "C²" is lowered the side of the lever is brought into contact with the inclined face of one of the blocks "E" and "F." It will be seen that when the lever "C²" is thrown over into either closed positions and brought into contact with the inclined blocks, that the inclined face of such blocks would further carry the lever over toward either of the closed positions, so as to bring the switch point positively tight into place. If any adjustment is required to bring the switch point more closely into position, the adjustment may be quickly and readily accomplished by turning the threaded nut "G⁴," so as to give a greater incline to the inclined blocks.

By my device the mast is retained intact and the adjustment automatically accomplished in a simple and efficient way by the operation of the operating lever.

What I claim as my invention is:

1. In a switch stand operating mechanism for switches, the combination with the

mast, the block secured to the mast and the operating lever pivoted between the jaws of the blocks, of inclined members supported by the switch stand and with which the operating lever is designed to be brought into contact as it is lowered at its closed positions, as and for the purpose specified.

2. In a switch stand operating mechanism for switches, the combination with the mast supported in the stand, the block secured to the mast provided with jaws and the operating lever pivoted between the jaws of a bracket forming part of the switch stand, wedge blocks supported by the bracket and with which operating lever is designed to be brought into contact, as it is lowered, as and for the purpose specified.

3. In a switch stand operating mechanism for switches, the combination with the mast supported in the stand, the blocks secured to the mast provided with jaws, and the operating lever pivoted between the jaws, of a bracket forming part of the switch stand, wedge blocks supported by the bracket and with which the operating lever is designed to be brought into contact as it is lowered, as adjustable means for increasing the incline of the blocks as and for the purpose specified.

4. In a switch stand operating mechanism for switches, the combination with the mast supported in the stand, the blocks secured to the mast provided with jaws and the operating lever pivoted between the jaws, of a bracket forming part of the switch stand, wedge blocks supported by the bracket and with which the operating lever is designed to be brought into contact as it is lowered, means for pivoting the block at the top, a

threaded bolt extending through the lower portion having an enlarged portion extending through the bracket, a nut threaded on to the bolt so as to engage the block between itself and the enlarged portion of the bolt as and for the purpose specified.

5. In a switch stand operating mechanism for switches, the combination with the mast having a crank thereon, of an operating lever and handle suitably secured to the mast and means for increasing the throw of the crank beyond the normal by throwing the operating lever from the horizontal to the vertical position as and for the purpose specified.

6. In a switch stand operating mechanism for switches, the combination with the mast, the block secured to the mast and provided with jaws and the operating lever pivoted thereon, of inclined members supported by the switch stand and with which the operating lever is designed to be brought into contact as it is lowered at its closed position.

7. In a switch stand operating mechanism for switches, the combination with the mast supported in the stand, a lever connected with the mast, and means for causing the lever to move about the axis of the mast as said lever is moved downwardly.

8. In a switch stand operating mechanism for switches, the combination with the mast supported in the stand, a lever connected with the mast, and adjustable means for causing the lever to move about the axis of the mast as said lever is moved downwardly.

ERNEST GEORGE JACKSON.

Witnesses:

LOUIS BAGINET,
S. B. RITCHIE.