

(No Model.)

C. W. NEEDLES.
SHOVELING BOARD FOR WAGONS.

No. 524,345.

Patented Aug. 14, 1894.

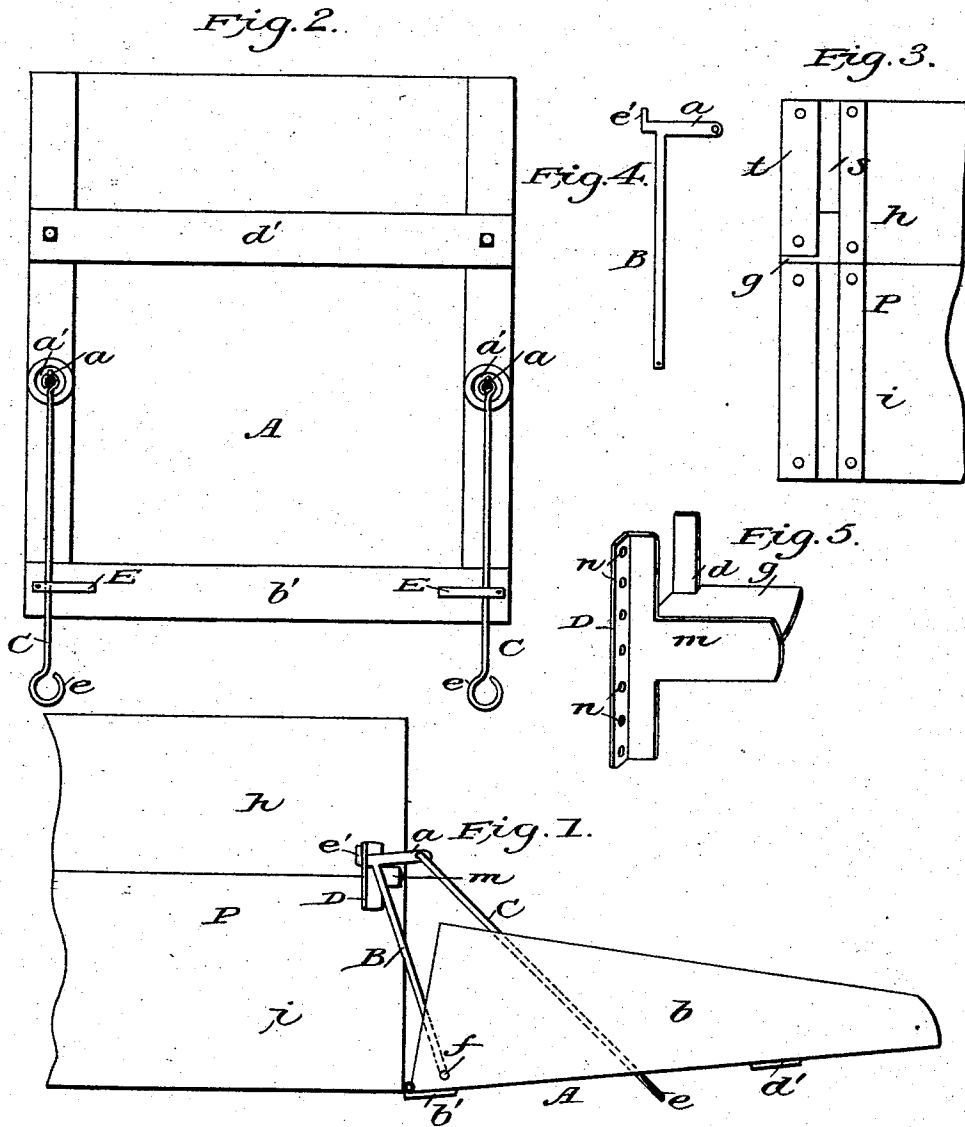

Witnesses.
Lilford, E. Ingess
Joseph, S. Goss

Inventor.
Charles W. Needles
By Thomas B. Swan
His Attorney

UNITED STATES PATENT OFFICE.

CHARLES W. NEEDLES, OF ATLANTIC, IOWA.

SHOVELING-BOARD FOR WAGONS.

SPECIFICATION forming part of Letters Patent No. 524,345, dated August 14, 1894.

Application filed March 12, 1894. Serial No. 503,322. (No model.)

To all whom it may concern:

Be it known that I, CHARLES W. NEEDLES, a citizen of the United States, residing at the city of Atlantic, in the county of Cass and State of Iowa, have invented certain new and useful Improvements in Shoveling-Boards; and I do declare the following to be a full, clear, and exact description of the invention, such as will enable others skilled in the art to which it appertains to make and use the same, reference being had to the accompanying drawings, and to the letters of reference marked thereon, which form a part of this specification.

My invention relates to improvements in shoveling-boards for wagons, and it consists in the peculiar construction and combination of the parts that will be more fully set forth hereinafter and particularly pointed out in the claims.

My invention relates especially to an improved means for securing the shoveling-board to the wagon box, consisting of supports or brackets, removably and readily secured to the sides of the wagon-box without the use of bolts or screws as hereinafter described, having apertures which receive the hooked ends of straps which are pivotally connected to the shoveling-board.

The objects of my invention are to provide a shoveling-board, which shall be simple in construction, economical in manufacture, durable in use, efficient and reliable in operation, and which can be readily secured to an ordinary farm wagon, without the use of bolts or screws. I attain these objects by the device illustrated in the accompanying drawings, in which—

Figure 1 is a view in side elevation of the shoveling-board showing the same open; Fig. 2, an end view of shoveling-board showing same closed; Fig. 3, a view in side elevation of the inside of one of the sides of the wagon-box; Fig. 4, a detailed view in side elevation of the rod or strap that connects the shoveling-board to the wagon-box; Fig. 5, an enlarged detailed perspective view of the support or bracket to which the shoveling-board is hinged.

Similar letters refer to similar parts throughout the several views.

In the accompanying drawings, P repre-

sents the rear portion of a wagon-box or wagon-bed.

A is the shoveling-board having the sides *b*.

D is a support or bracket provided with a series of apertures *n*, and having secured thereto and made integral therewith the plate *m*, plate *g*, and prong *d*.

B is a supporting strap having at its upper end the hook *e'* and laterally projecting arm *a*, each made integral with said strap, the lower end of the strap is pivoted by the pivot *f* to the side of shoveling-board, and the upper end is hinged, by means of the hook *e'* which enters one of the apertures *n*, to the support or bracket D.

There are two supports D, and two straps B, one of each being on each side of wagon-box.

C C are rods having loops *e e* at their lower ends and having their upper ends bent or looped so that they pass through apertures adapted to receive them in the outer ends of the arms *a a*, thereby hinging the rods to the arms *a a*. *d'* and *b'* are cleats secured to shoveling-board.

E E are spring-clamps secured to the cleat *b'* of the shoveling board.

a' a' are apertures through which the rods C C loosely play when the shoveling-board is being opened or closed, and into which the arms *a a* of the strap B enter when the shoveling-board is closed. The loops *e e* of the rods C C are of such size that they will not pass through the apertures *a' a'*, so that when the shoveling-board is open the same rests upon the loops *e e*.

t and *s* are cleats such as are commonly secured to farm wagons and between which the ordinary farm wagon end-gate is located and retained.

h is the upper side board of the wagon-box and *i* the lower board of the wagon box, the upper board *h*, being secured to the lower board and separable therefrom in the usual manner. The plate *m* of the support or bracket D bears against the outside of the wagon-box, and the plate *g* thereof rests between the upper and lower boards of the wagon-box, and the prong *d* thereof is located between the cleats *t* and *s* and bears against the inside of the wagon-box.

The support or bracket D is secured to an ordinary farm wagon, without the use of bolts or screws, in the following manner: Remove the ordinary end-gate from between the cleats *t* and *s* that retain it, then separate the side boards of the wagon-box sufficiently to permit the insertion of the prong *d* between the cleats *t* and *s*, then insert the prong between the cleats *t* and *s* in such a manner that the upper portion of the plate *m* and the prong will straddle the upper side board *h* of the wagon-box, then force the side board *h* downward into its proper and usual position so that the plate *g* of the support D will rest snugly between the upper and lower side boards. After securing to each side of the wagon-box a support D as hereinbefore explained, the shoveling-board can be readily secured to the wagon-box by inserting the hooked ends of the straps B into the proper apertures *n* of the support D.

On account of farm wagons being constructed with lower side boards of various heights it is necessary to have the series of apertures *n* in the support D, for the insertion of the hooked ends of the straps B, and the hooks should be inserted in such apertures *n*, that will cause the lower inner end of the shoveling-board, when it is open, to abut against the lower part of the wagon-box.

When the shoveling-board is closed it is held firmly in position by inserting the lower portion of the rods C C under the free ends of the spring-clamps E E.

The shoveling-board can be readily opened by removing the rods C C from under the spring-clamps and permitting the rods to slide through the apertures *a'* until the shoveling-board rests upon the loops *e e* of the rods.

Having described my invention, what I claim as new, and desire to secure by Letters Patent, is—

1. In a shoveling-board, the combination

substantially as described of the bracket or support D, secured to the side of the wagon-box, the supporting strap B, pivoted at its lower end to the shoveling-board, and secured at its upper end to the support D, and being provided with the laterally projecting arm *a*, the shoveling board A, and the rod C, which passes through the aperture *a'*, of the shoveling-board, and is hinged at its upper end to the arm *a*.

2. A shoveling-board support or bracket consisting of a perforated plate, having secured thereto a fastening therefor, which passes between the side boards of the wagon-box, and which straddles the side board of the wagon box, substantially as described.

3. The means for securing the shoveling board bracket to the wagon box, consisting of the plate which is firmly secured to the bracket and which passes between the side boards of the wagon box and is provided at its inner end with a prong, projecting laterally therefrom, which fits between the cleats usually employed to retain the end-gate of the wagon box, substantially as described.

4. The herein described shoveling-board support consisting of the plate having a series of perforations, the plate *m*, secured thereto, the plate *g*, secured to the plate *m*, and the prong or plate *d*, secured to the plate *g*, substantially as described.

5. A shoveling-board provided with a supporting strap pivoted thereto, having at its upper end a laterally projecting arm to which a supporting rod is secured, substantially as described.

In testimony whereof I affix my signature in presence of two witnesses.

CHARLES W. NEEDLES.

Witnesses:

C. NORTHUP,
MILO B. KENYON.