



(12) **DEMANDE DE BREVET CANADIEN
CANADIAN PATENT APPLICATION**

(13) **A1**

(86) Date de dépôt PCT/PCT Filing Date: 2018/12/05
(87) Date publication PCT/PCT Publication Date: 2019/06/13
(85) Entrée phase nationale/National Entry: 2020/05/29
(86) N° demande PCT/PCT Application No.: US 2018/064141
(87) N° publication PCT/PCT Publication No.: 2019/113259
(30) Priorités/Priorities: 2017/12/06 (US62/573,578);
2018/06/07 (US62/682,091)

(51) Cl.Int./Int.Cl. *A61K 9/50* (2006.01),
A61K 9/51 (2006.01), *A61K 9/52* (2006.01),
B01J 13/20 (2006.01), *B41M 5/165* (2006.01),
B65B 29/10 (2006.01)
(71) Demandeur/Applicant:
JONES, JAMES PHILLIP, US
(72) Inventeur/Inventor:
JONES, JAMES PHILLIP, US
(74) Agent: MCMILLAN LLP

(54) Titre : SYSTEME DE CAPSULE DE PRELEVEMENT
(54) Title: SAMPLING CAPSULE SYSTEM

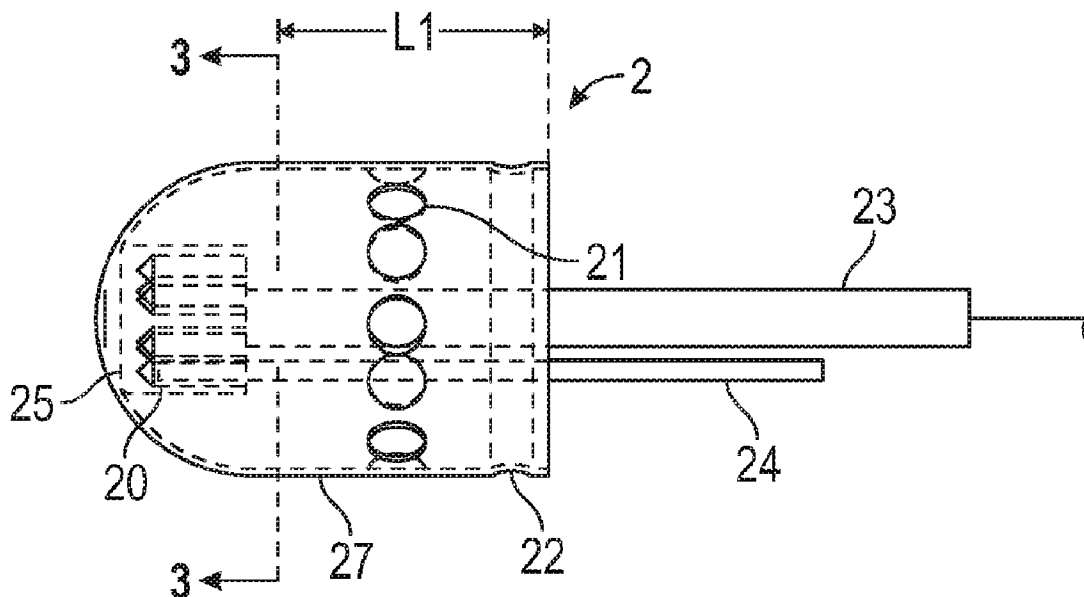

FIG. 1

(57) **Abrégé/Abstract:**

A non-invasive system for sampling gastrointestinal microbiota with their associated environment for discovery, characterization, medical research, diagnostics, and treatment using an ingestible, non-digestible sampling capsule. The capsule device, with ports open for acquiring a sample of gastrointestinal microbiota and content, is placed inside an immediate or delayed release capsule. When the outer capsule dissolves according to its specifications, enteric fluid and content enters the sampling capsule through the ports triggering a hydrophilic stop to release a pulling force to close the ports by enveloping the capsule outer casing over the inner casing, capturing the sample, and holding it sealed until it completes passage through the digestive track, and is recovered from feces for analysis.

(12) INTERNATIONAL APPLICATION PUBLISHED UNDER THE PATENT COOPERATION TREATY (PCT)

(19) World Intellectual Property
Organization
International Bureau

(43) International Publication Date
13 June 2019 (13.06.2019)



(10) International Publication Number
WO 2019/113259 A1

(51) International Patent Classification:

A61K 9/50 (2006.01) *B65B 29/10* (2006.01)
A61K 9/51 (2006.01) *B01J 13/20* (2006.01)
A61K 9/52 (2006.01) *B41M 5/165* (2006.01)

(21) International Application Number:

PCT/US2018/064141

(22) International Filing Date:

05 December 2018 (05.12.2018)

(25) Filing Language:

English

(26) Publication Language:

English

(30) Priority Data:

62/573,578 06 December 2017 (06.12.2017) US
62/682,091 07 June 2018 (07.06.2018) US

(72) Inventor; and

(71) Applicant: **JONES, James, Phillip** [US/US]; 402 West FM 303, Sudan, TX 79371 (US).

(74) Agent: **NAECKEL, Arno, T.**; 15850 N. Thompson Peak Pkwy, #2161, Scottsdale, AZ 85260 (US).

(81) Designated States (unless otherwise indicated, for every kind of national protection available): AE, AG, AL, AM, AO, AT, AU, AZ, BA, BB, BG, BH, BN, BR, BW, BY, BZ, CA, CH, CL, CN, CO, CR, CU, CZ, DE, DJ, DK, DM, DO, DZ, EC, EE, EG, ES, FI, GB, GD, GE, GH, GM, GT, HN, HR, HU, ID, IL, IN, IR, IS, JO, JP, KE, KG, KH, KN, KP, KR, KW, KZ, LA, LC, LK, LR, LS, LU, LY, MA, MD, ME, MG, MK, MN, MW, MX, MY, MZ, NA, NG, NI, NO, NZ, OM, PA, PE, PG, PH, PL, PT, QA, RO, RS, RU, RW, SA, SC, SD, SE, SG, SK, SL, SM, ST, SV, SY, TH, TJ, TM, TN, TR, TT, TZ, UA, UG, US, UZ, VC, VN, ZA, ZM, ZW.

(84) Designated States (unless otherwise indicated, for every kind of regional protection available): ARIPO (BW, GH, GM, KE, LR, LS, MW, MZ, NA, RW, SD, SL, ST, SZ, TZ, UG, ZM, ZW), Eurasian (AM, AZ, BY, KG, KZ, RU, TJ, TM), European (AL, AT, BE, BG, CH, CY, CZ, DE, DK, EE, ES, FI, FR, GB, GR, HR, HU, IE, IS, IT, LT, LU, LV, MC, MK, MT, NL, NO, PL, PT, RO, RS, SE, SI, SK, SM, TR), OAPI (BF, BJ, CF, CG, CI, CM, GA, GN, GQ, GW, KM, ML, MR, NE, SN, TD, TG).

(54) Title: SAMPLING CAPSULE SYSTEM

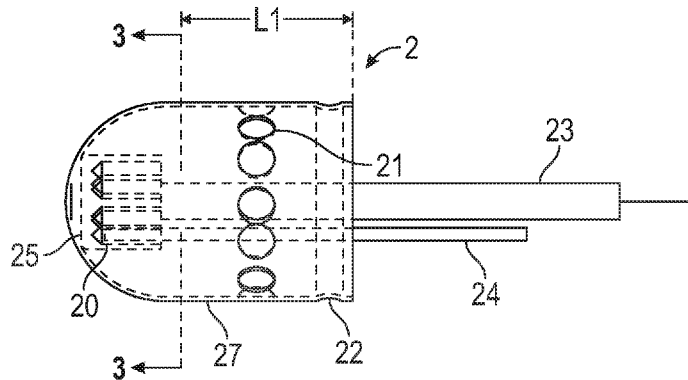

FIG. 1

(57) Abstract: A non-invasive system for sampling gastrointestinal microbiota with their associated environment for discovery, characterization, medical research, diagnostics, and treatment using an ingestible, non-digestible sampling capsule. The capsule device, with ports open for acquiring a sample of gastrointestinal microbiota and content, is placed inside an immediate or delayed release capsule. When the outer capsule dissolves according to its specifications, enteric fluid and content enters the sampling capsule through the ports triggering a hydrophilic stop to release a pulling force to close the ports by enveloping the capsule outer casing over the inner casing, capturing the sample, and holding it sealed until it completes passage through the digestive track, and is recovered from feces for analysis.

[Continued on next page]



WO 2019/113259 A1

WO 2019/113259 A1 

Published:

— *with international search report (Art. 21(3))*

SAMPLING CAPSULE SYSTEM

PRIORITY APPLICATIONS

[0001] The present Paris Cooperation Treaty (PCT) application claims priority from both United States provisional applications 62/573,578 filed on December 6, 2017 and 62/682,091 filed on June 7, 2018, both of which are incorporated herein by reference in their entireties.

BACKGROUND OF THE INVENTION

[0002] Field of Invention

[0003] The present invention relates to at least one device, at least one system, at least one process or method thereof to be used within the medical sciences, engineering, research and medical technologies. The device is ingestible and is untethered and is designed to collect samples from or release substances into a gastrointestinal tract.

[0004] Description of the Related Art

[0005] Major scientific research and medical efforts are being dedicated to discovering an ever increasing amount of knowledge regarding the roles played in human and animal life and disease by gastrointestinal microbes. An individual's gastrointestinal microbiome varies with location and time due to a multitude of factors including symbiosis and antibiosis relationships, time, ingesta, age, and health. Microbiota taxa vary from location to location in the digestive tract becoming increasingly diverse and abundant through the differing stages of the digestive tract from the stomach to the colon. One published estimate indicates that approximately 10^4 microbes are found in the small intestine and 10^{10} microbes (or 50% of the fecal mass) are found in the colon. The nature of the microbes and their function remain much of a mystery due to inaccessibility of the gut, the lack of an effective means to sample and characterize them, and the complex symbiotic relationships in their localized taxa.

[0006] Medicine has advanced in all major human body systems, such as cardiovascular, neurological, muscular and skeletal, but the intestinal tract still remains much of a mystery. Though there are instruments and devices which can be used for endoscopy/colonoscopy, there are sections of intestines that remain unexplored and are found incredibly difficult to collect and preserve samples there from. Even these upper and lower extremities, which can be viewed by camera and can only be treated for visible damage, such as polyps or ulcers. The roles bacteria play in the intestinal tract are poorly understood, except that there are "good" and "bad" bacteria. In fact, only a few of the estimated thousands of strains of bacteria are known, or have been

identified, have been characterized and their roles determined. One known device is of a camera pill that can now be swallowed and pictures taken throughout the intestinal tract, but visible inspection does not address the scientific mysteries of diseases and their causes or cures.

[0007] Specifically, the human gut is a huge void in medical science. The aim of this invention is to help determine information such as: what biochemical products exist for any specific diet as a function of the gut length x ; what biochemical reactions take place along the gut length x ; what microbes exist at any point within the gut anatomical system; what are the byproducts of all microbes including their toxins, exotoxins and endotoxins, and virulence factors and enzymes existing within the gut. Further, the interaction of a) the normal biochemical reactions, b) the microbes, and c) the microbe byproducts are largely unknown, and believed to be a major source of several major diseases. Some 15 categories of bacteria have been broadly identified within the Phylogenetic Tree as existing within major components of the gastrointestinal tract. Thus, in general, bacteria strains and colonies and their populations, population densities, habitats, and characteristics and contributions to the digestive process are only vaguely known in healthy individuals, and largely unknown in unhealthy individuals, much less as a function of gut length x .

[0008] The inaccessible regions of the most important anatomy of the gut, and the lack of technology to explore, discover, and experiment in an *in vivo* manner, and then administer medications and measure *in vivo* the immediate results, has constrained and obstructed beyond description throughout history the advance of medical science pertaining to the gut. A competent research effort investigating any animate or inanimate system should attempt to identify the fundamental multidisciplinary scientific principles of science and engineering upon which the system is based and functions, and then develop quantitative measures of those principles. The inaccessibility of the gut, and heretofore lack of technology, has resulted in speculation and statistical correlation of symptoms from a distance throughout history as a means of researching the gut. The need for *in vivo* technology became immediately apparent. The first step to further this technology is the determination of what exists at various distances x along the gastrointestinal tract.

[0009] Noninvasive sampling processes are presently limited to oral spit, internal swabs, and feces analysis. Minimal invasive sampling processes include swabs of the rectum. They do not provide for examination of localized microbiota community content within the gut that is important, for example, to gain understanding of bacteria and host-bacterial interactions. This is complicated by changing environmental conditions such as pH and the release of resident bacteria and other microbiota (alive and dead), bodily chemistry, particles, and fluids from

upstream regions of the gastrointestinal tract that transit through the intestines and are subsequently detectable in feces. The intraluminal pH is rapidly changed from highly acid in the stomach (pH 1-3.5) to about pH 6 in the duodenum. The pH gradually increases in the small intestine from pH 6 to about pH 7.4 in the terminal ileum. The pH drops to 5.7 in the caecum, but again gradually increases, reaching pH 6.7 in the rectum. Feces confounds characterization of microbial communities that are extremely diverse and include a large number of Gram-positive eubacteria, Gram-negative bacteria, cyanobacteria, archaea, fungi, protozoa, and virus as luminal communities within the colon that differ, for example, from dynamic mucosa-associated communities found in the small intestine.

[0010] Invasive gastroscopy and endoscopy procedures are used to sample microbiota of the upper gastrointestinal track of the esophagus, stomach, and duodenum and for the lower intestinal tract of the colon, large intestine, and lower portion of small intestine, but approximately 5m of ileum and jejunum cannot be reached for scope sampling. Both scopes necessitate expensive procedures and require anesthesia, risk, and recovery in a medical setting. They are a poor strategy for time course data acquisition, diagnosis support, or treatment support.

[0011] Efforts to find an effective method to sample intestinal microbiota in their local area have not met with success, indeed citations show there have been inventive efforts including ingestible capsules operated with electrical circuits, batteries, radio, magnetic fields, steel compression and torsion springs working alone or together, and vacuums. Examples of such contributions may be found in U.S. Pat. Nos. 8,491,495, 8,915,863, 8,926,526, 9,215,997, and 9,955,922 to Shuck and all of which are included herein by reference in their entireties. However, these devices and methods are not in present use and appear to be impractical for production or general use. Research, medical communities, and patients beg novel solutions that can be repetitively used at home or in a general medical practice setting.

[0012] The subject matter herein comprises a mechanical device and system for acquiring samples of matter along an intestinal track of a user in-vivo. The device is a capsulized device and system configured to be swallowed and passed through the intestinal track. The device comprises a hollow casing or housing defining one or more openings adapted to allow samples of liquid and semi-liquid matter to pass into the housing during a specified time interval and then sealed therein for collection outside the body for analysis. Further, embodiments are capable of releasing substances stored within the device into the surrounding environment.

SUMMARY

[0013] The subject matter presented herein describes a sampling system comprising an inner capsule and an outer casing. The inner casing comprises a ported first casing with an open end, a closed end, an inner surface, and an outer surface and a ported second casing with an open end, a closed end, an inner surface, and an outer surface. The system further comprises a hydrophobic, acid resistant elastomeric filament fixedly attached to the closed end of the ported first casing and to the closed end of the ported second casing, a hydrophilic strut, wherein the hydrophilic strut spaces the closed end of the ported first casing away from the closed end of the ported second casing and is of such a length as to impart a tension in the hydrophobic elastomeric filament; and a first digestible outer capsule enveloping the inner capsule, the first digestible outer capsule being configured to temporarily isolate the inner capsule from bodily fluids.

[0014] The subject matter presented herein also describes a gastrointestinal sampling device comprising a hollow capsule having a ported inner casing with a closed end and an open end and having a ported outer casing with a closed end and an open end, an elastomeric filament fixedly securing the closed end of the inner casing to the closed end of the outer casing; and a hydrophilic strut spacing the closed end of the inner casing away from the closed end of the outer casing when intact.

[0015] The subject matter presented here in further describes a gastrointestinal sampling system comprising a hollow capsule having a ported inner casing having a closed end and an open end slidingly engaged within a ported outer casing also having a closed end and an open end; and, an elastomeric filament fixedly securing the closed end of the inner casing to the closed end of the outer casing.

BRIEF DESCRIPTIONS OF THE DRAWINGS

[0016] FIG. 1 depicts a perspective view of an exemplary ported inner casing of the gastrointestinal sampling device according to an embodiment.

[0017] FIG. 2 depicts a perspective view of an exemplary ported outer casing of the gastrointestinal sampling device according to an embodiment.

[0018] FIG. 3 depicts a cross-sectional view of an exemplary ported inner casing of the gastrointestinal sampling device according to an embodiment.

[0019] FIG. 4 depicts a cross-sectional view of an exemplary ported outer casing of the gastrointestinal sampling device according to an embodiment.

[0020] FIG. 5 depicts a perspective view of an assembled gastrointestinal sampling device in the strutted, open configuration.

[0021] FIG. 6 depicts a perspective view of the gastrointestinal sampling device in the closed configuration.

[0022] FIG. 7 is a side view of the gastrointestinal sampling device in the strutted open configuration.

[0023] FIG. 8 is a cross sectional view of the gastrointestinal sampling device of FIG. 7.

[0024] FIG. 9 is a side view of the gastrointestinal sampling device of FIG. 7 in the sealed closed configuration after the hydrophilic elastomeric filament fails.

[0025] FIG. 10 depicts an exploded perspective view of a gastrointestinal sampling device according to an embodiment with a compound strut.

[0026] FIG. 11 is a cross sectional view of the outer ported casing of FIG. 10.

[0027] FIG. 12 is a perspective view of the assembled gastrointestinal sampling device of FIG. 10 in its open configuration.

[0028] FIG. 13 is a perspective view of the assembled gastrointestinal sampling device of FIG. 10 in its closed configuration.

[0029] FIG. 14 is a cross sectional view of an assembled gastrointestinal sampling system in its open configuration inside a digestible outer casing.

[0030] FIG. 15 is a cross sectional view of an assembled gastrointestinal provision system in its closed configuration inside a digestible outer casing.

[0031] FIG. 16 is a cross sectional view of an assembled gastrointestinal provision system in its closed configuration inside a digestible outer casing and an inner thin casing.

DETAILED DESCRIPTION

[0032] The following detailed description is merely exemplary in nature and is not intended to limit the invention, or the application, or uses of the subject matter disclosed. As used herein, the word “exemplary” means “serving as an example, instance, or illustration.” Thus, any embodiment described herein as “exemplary” is not necessarily to be construed as preferred or advantageous over other embodiments. All of the embodiments described herein are exemplary embodiments provided to enable persons skilled in the art to make or use the invention and not to limit the scope of the invention which is defined by the claims. Furthermore, there is no intention

to be bound by any expressed or implied theory presented in the preceding technical field, background, brief summary, or the following detailed description.

[0033] The terminology used herein is for the purpose of describing particular embodiments only and is not intended to be limiting of the invention. As used herein, the term “and/or” includes any and all combinations of one or more of the associated listed items. As used herein, the singular forms “a,” “an,” and “the” are intended to include the plural forms as well as the singular forms, unless the context clearly indicates otherwise. It will be further understood that the terms “comprises” and/or “comprising,” when used in this specification, specify the presence of stated features, steps, operations, elements, and/or components, but do not preclude the presence or addition of one or more other features, steps, operations, elements, components, and/or groups thereof.

[0034] New electronic device cases and apparatuses are discussed herein that are configured to receive and secure a portable electronic device. It should be understood that for the purposes of understanding the orientation of individual elements or components of the invention, the terms “front” and “front side” shall generally be used to indicate a surface or surface of an element or component that when assembled in a protective mobile device case apparatus, is orientated toward the primary display screen of the portable electronic device. Conversely, for the purposes of understanding the orientation of individual elements or components of the invention, the terms “back” and “back side” shall generally be used to indicate a surface or a surface of an element or component that when assembled in a protective mobile device case apparatus is orientated away from (i.e. faces away from) the primary display screen of the electronic device.

[0035] It should also be understood that the terms “right” and “left” are used solely to denote opposite sides of an element, component, or surface in the same manner that “top” and “bottom” are used solely to denote opposite sides of an element, component, or surface and should not unnecessarily be construed as limiting the position or orientation of said element, component, or surface.

[0036] In the following description, for purposes of explanation, numerous specific details are set forth in order to provide a thorough understanding of the present invention. It will be evident, however, to one skilled in the art that the present invention may be practiced without these specific details.

[0037] In this document, relational terms such as first and second, and the like may be used solely to distinguish one entity or action from another entity or action without necessarily requiring or implying any actual such relationship or order between such entities or actions.

Numerical ordinals such as "first," "second," "third," etc. simply denote different singles of a plurality and do not imply any order or sequence unless specifically defined by the claim language. The sequence of the text in any of the claims does not imply that process steps must be performed in a temporal or logical order according to such sequence unless it is specifically defined by the language of the claim. The process steps may be interchanged in any order without departing from the scope of the invention as long as such an interchange does not contradict the claim language and is not logically nonsensical.

[0038] Furthermore, depending on the context, words such as "connect" or "coupled to" used in describing a relationship between different elements do not imply that a direct physical connection must be made between these elements. For example, two elements may be connected to each other physically, electronically, logically, or in any other manner, through one or more additional elements.

[0039] Reference should now be made to the drawings in which the same reference numbers are used throughout the various figures to designate the same or similar components. **FIG. 1** (inner casing **2**) and **FIG. 2** (outer casing **4**) are each one-piece acid tolerant medicinal grade elastomer or metallic devices with port holes **21** that penetrate through casing walls **27** and **26**, respectively. When assembled the inner casing **2** and the outer casing **4** comprise the gastrointestinal sampling device **1**. The inner casing **2** and the outer casing **4** may be circular cylinders, each with a domed closed end portion. However, different shapes may be employed that provide efficient or structural advantage in a given situation, including a simple sphere.

[0040] As a non-limiting example, a gastrointestinal sampling device **1** may have an open configuration length of approximately 24 mm and a closed configuration length of approximately 20 mm. The inner casing **2** may have a diameter of approximately 9.0 mm. The outer casing **4** may have a diameter of 9.91 mm. When in the closed configuration, the volume of the enclosed sample may be approximately 0.50 ml or eight (8) drops of fluid sample. The material of the gastrointestinal sampling device **1** may be a molded biomedical ingestible grade elastomer with a Shore A hardness of approximately 40.

[0041] The number of ports **21**, their size, shape, or their configuration on the casings may be varied to satisfy sample collection or material delivery efficacy. However, it should be noted that the casing walls **26** and **27** are of such lengths **L1** and **L2** so as to cover and effectively seal the ports **21** in the other casing's walls such that all of the holes **21** in the gastrointestinal sampling device are fluid tight such that the sample enclosed therein does not leak out after the time of closing.

[0042] Each of the inner casing **2** and outer casing **4** includes its own receiver **25** and **29**, respectively. Receivers **25** and **29** are used to guide and support a strut **24** within one pair of multiple channels **20** and **28**, respectively.

[0043] In some embodiments, strut **24** may be physically fashioned out of a single piece of medical grade hydrophilic material such that the hydrophilic action strut **24** rapidly fails upon contact with a specified bowel material, acid, chemical or with fluids generally. Alternatively, the strut **24** may be engineered to fail after a period of time (a delayed action strut) rather than immediately (an immediate action strut). The time to fail may be controlled by the choice of material, the physical shape of the strut or both. One such material may be cellulose. Other possible materials include polyvinyl alcohol, seaweed derivatives from the Evoware Company of Indonesia, casein proteins developed by the US Department of Agriculture, Agar, and the root of the cassava plant produced by the Avani Company of Bali. In short, any suitable medical grade dissolvable/digestible material may be used that currently exists or that may be developed in the future. The term “digestible” as used herein in regard to an outer capsule means “able to be softened or decomposed by heat and moisture or chemicals,” such as may be found in the digestive tract.

[0044] In other embodiments (See, e.g. **FIGs. 12-13**), strut **24** may be comprised of two or more hydrophobic members (**24A-B**) temporally connected by an attachment means **40** such as an adhesive, a pin, or similar means that may currently exist or be developed in the future. In some embodiments the attachment means may be a hydrophilic attachment means such that bowel material or fluid attacks only the attachment means **40** and not the hydrophobic members themselves. This multiple piece embodiment of strut **24** may also be referred to a hydrophilic action strut **24** but may be claimed in alternative language such as an immediate release strut. In other embodiments the attachment means **40** may be comprised of a pH sensitive material and may be termed a pH attachment means or a delayed action strut. A non-limiting example of an adhesive suitable for purpose of attaching two hydrophobic struts is polyvinyl alcohol, which may be both a hydrophilic attachment means and a pH attachment means.

[0045] As a non-limiting example the strut **24** may have a length **L** of approximately 20.5 mm and a diameter of 1.3 mm. Strut **24** may be a cylinder or a parallelepiped and may be further shaped to tailor the timing of its failure to a desired time period, including immediate failure upon contact with an intestinal fluid.

[0046] Inner casing **2** and outer casing **4** are mated by inserting one end of strut **24** into one of the channels (**20, 28**) in receiver (**25, 29**) of one casing (**2, 4**) and the other end into a corresponding channel (**20, 28**). The number of channels (**20, 28**) may vary but there must be

at least one channel in one of the two casings. In some embodiments, the closed ends of the inner casing **2** and the outer casing **4** may each include a hole **31** penetrating through both of the center of the receiver and the center of closed end of each casing to accept and pass through an elastomeric filament **23**.

[0047] Elastomeric filament **23** may be attached to the same receivers (**25, 29**) as the strut **24** in both the inner and outer casings and is partially relaxed until both ends of strut **24** engage one of the channels (**20, 28**) in a casing, thereby requiring elastomeric filament **23** to stretch. In some embodiments the elastomeric filament **23** extends through the receiver(s) (**25, 29**) and into a hole **31** in the closed end(s) of one or both casings (**2, 4**) and is attached therein. The end of elastomeric filament **23** may be tensioned and then affixed to the walls of the receiver defining the hole **31** by welding or gluing to make the hole(s) **31** fluid tight. A non-limiting example of a glue for this purpose is Cyanoacrylate.

[0048] When the inner casing **2** is partially inserted into the outer casing **4** and spaced apart by the strut **24** with a length **L**, the elastomeric filament **23** may be trimmed flush to the outer surface of casing (**2, 4**). The length **L** of strut **24** is such that when inserted into both receivers (**25, 29**) it maintains the gastrointestinal sampling device **1** in its open configuration with all ports **21** unobstructed while imparting a tension in the elastomeric filament **23** (see, **FIG. 5**). The tension strains against the strut to place the gastrointestinal sampling device **1** into its closed configuration (see, **FIG. 6**). It should be noted that the elastomeric filament **23** is of a length that is less than the distance between receivers (**25, 29**) such that it continues to maintain the inner casing **2** and outer casing **4** into the closed configuration in the absence of an intact strut **24**.

[0049] In some embodiments the elastomeric filament **23** is comprised of an elastomer that is non-reactive to, or it is at least resistant to digestion by, bodily fluids. In some cases the elastomeric filament **23** may be notably acid resistant if it is to operate in the stomach where the gastric environment is at a pH of 3.0 and lower. A non-limiting example of a substance that is suitable for the elastomeric filament **23** is a medical grade silicone rubber.

[0050] Strut **24** holds the assembled gastrointestinal sampling device **1** in its open configuration, or open port position, against the tension provided by the elastomeric filament **23** until the strut **24** is weakened and fails by inflowing enteric fluids and collapses allowing the pulling tension to further encourage travel of outer casing **4** over inner casing **2** to close ports **21** by overlap of the casings. The two casings are secured in the closed configuration by a male locking stop ring **32** in one of the casings that is configured to lock by interference fit into the female locking stop ring **22** in the other casing. The residual tension remaining in

elastomeric filament **23** insures that the gastrointestinal sampling device **1**, and the capsule ports **21**, remain closed while the gastrointestinal sampling device **1** and it captured sample is recovered. Instead or, or in addition to, an O-ring may also be employed to help seal the device in its closed configuration.

[0051] In some embodiments the inner capsule can carry delayed release compounds to “fix” or preserve the sample flowing in through the ports. For example the fluid flowing into the inner capsule triggers the strut collapse. At the same time, the fluid also starts dissolving the preservative. When the capsule is recovered it can be kept inside the closed capsule for storage. There are several chemical approaches to preserving samples as may be known in the art but they should not have reactive effect on the microbiota. Such, a preservative may be obtained from DNA Genotek, a Lonza company located in Kanata, Ontario, Canada.

[0052] **FIGs. 3 and 4** are cross sectional views of **FIGs. 1 and 2**. As can be seen in **FIG. 3**, strut **24** is inserted in one of the chambers **20** of receiver **25**, and elastomeric filament **23** is secured to the closed end of inner casing **2**.

[0053] **FIG. 7** is a side view of the inner casing **2** partially and slideably inserted into the outer casing **4** and thereby assembled into the gastrointestinal sampling device **1** in its open configuration. As can be seen the ports **21** are all open and the strut **24** is in place keeping the device in its open configuration.

[0054] **FIG. 8** presents a cut away view of **FIG. 7** revealing both the strut **24** supporting the open port configuration and elastomer band **23** providing a persistent contracting force in contravention. **FIG. 8** also shows the female stop ring **22** and the male stop ring **32**. When the strut **24** fails and the elastomeric filament **23** pulls the inner and outer casings together, the stop male stop ring **32** inserts itself into the female stop ring **22**, thereby encouraging the gastrointestinal sampling device **1** to stay in its closed configuration along with any residual tension from the elastomeric filament **23**. It should be understood that in other equivalent embodiments the stop rings **22** and **32** may be designed differently as may be known in the art with a similar effect. For example, there may be a stop ring, or rib, or edge created on the exterior side of the wall **27** that engages and stops the sliding advance of the edge of outer casing **4**. Hence, the example of stop rings (**22, 32**) described herein is a non-limiting example.

[0055] **FIG. 9** is a side view of the gastrointestinal sampling device **1** in its closed configuration. As a means of identifying one gastrointestinal sampling device **1** from another, each device may carry a radio frequency identification device (RFID) transponder **42**. A RFID is well known in the art and needs not be discussed further herein.

[0056] **FIG. 10** is an exploded side view of another embodiment of the gastrointestinal sampling device **1**. The gastrointestinal sampling device **1** is similar to that of combined **FIGs. 1-2**. However, the gastrointestinal sampling device **1** of **FIG. 10** has one receiver **29**, which is in outer casing **4** and comprises only three channels **20**. The receiver **25** in inner casing **2** has no channels. In this embodiment, the strut **24** merely abuts the flat surface of the receiver **25**. The strut **24** of the embodiment of **FIG. 10** is a compound strut comprising two or more hydrophobic components **24A** and **24B** secured together by a hydrophilic attachment means **33**. A non-limiting example of a hydrophilic attachment means is a polyvinyl alcohol or polyvinyl alcohol glue.

[0057] In use as a sampling system **3** (see, **FIGs. 14-15**), the gastrointestinal sampling device **1** is fluidly isolated within one of a wide choice of available delayed or immediate release digestible outer capsules **10** (see, **FIG. 14**) as are known in the art, and is ingested. The outer capsule **10** may be chosen or designed to dissolve in an proscribed amount of time after ingestion, which implies failure of its fluid tight integrity at an approximate location along gut length *x*. Design parameters of the outer capsule related to time of failure of its fluid tight integrity include choice of material, thickness of the material, shape of the capsule, and mechanical weakening to intentionally create weak points in the capsule that may open faster than a general failure. Because stomach acid ranges from a pH of 1-3.5, the outer capsule **10** may necessarily need to be acid resistant below a 3.5 pH from a few minutes for liquids to five hours for meat and high fat substances. Thickness and material can adjust for this timing.

[0058] The digestible outer capsule **10** is an excipient that dissolves in the stomach or intestines in a desired timeframe providing fluid access to and through the normally open ports **21** of the gastrointestinal sampling device **1**. The fluid flow here comprises local community microbiota along with their environment including ingesta, loosely adherent mucus layer particles, and bodily chemistries into the gastrointestinal sampling device **1**. The fluid flow enters the gastrointestinal sampling device **1**, envelopes the dissolvable, non-toxic strut **24** causing it to fail structurally, which in turn allows the tension provided by the elastomeric filament **23** to pull or slide the inner casing **2** further into the outer casing **4** and hold gastrointestinal sampling device **1** in a closed, sealed port position (see, **FIG. 13**). The capsule continues through the gastrointestinal tract and is recovered from the stool, cleaned, identified by the RFID tag **42**, and can be opened for analysis or frozen for future analysis. The RFID tag contains information such as when the gastrointestinal sampling device was ingested, in what order, and the parameters of its digestible outer capsule **10**. The circuitry of the RFID tag may include a sub-circuit wherein the sub-circuit is closed when the inner capsule **1** is in the closed configuration and is open in the open configuration. As such, it can be electronically determined where the capsule is located

and if it is open or closed. A device with multiple receivers or multiple transceivers may provide a location in three dimensions.

[0059] As discussed above the physical and chemical parameters of the digestible outer capsule **10** will indicate approximately where in the gastrointestinal tract the sample was taken based on an expected elapsed time to dissolution. Alternatively, the outer capsule **10** may be comprised of a material that only deteriorates in the presence of certain enzymes, bacteria, or the immediate byproducts thereof.

[0060] The outer digestible capsule(s) **10** may be a standard state of the art publicly available or proprietary biomedical immediate or delayed release gastrointestinal capsule. Enteric capsules are capable of protecting the inner capsule from the strong acidity of the stomach for later disintegration in the intestines. Other non-limiting examples of possible digestible materials include polyvinyl alcohol, seaweed derivatives from the Evoware Company of Indonesia, casein proteins developed by the US Department of Agriculture, Agar, and the Cassava root from the Avani Company of Bali. Other non-limiting examples of biodigestible polymers may include Polyactic acid and Polly-3-hydroxybutyrate (PHB). Suitable proprietary materials may also be obtained from Capsugel of Morristown, Jew Jersey, USA and the Eudragit® brand of pH sensitive materials from Evonik Industries AG of Essen, Germany.

[0061] In short, any suitable medical grade dissolvable/digestible material may be used that currently exists or that may be developed in the future. The outer capsule may be approximately 25.5mm in length with a diameter of approximately 8.7-9.95 mm.

[0062] In other embodiments, an interstitial thin capsule or “skin” **11** (see, **FIG. 16**) may be incorporated between the outer capsule **10** and the gastrointestinal sampling device **1**, thereby providing a two parameter selection mechanism to taking a sample. For example, the outer capsule **10** may fail at a pH of 5.8 or less and the inner thin capsule **11** may be designed to deteriorate on contact with a certain bacteria. Only when both capsules fail will a sample be captured as discussed above.

[0063] Furthermore, the gastrointestinal sampling system **3** may include another embodiments of ingestible capsule **10** that may be used independently or in conjunction with the ingestible capsule of **FIG. 14**. For example, **FIG. 15** depicts another embodiment of the gastrointestinal sampling device **1A**, that may operate to deliver a drug, device or other substance to a targeted area of the digestive tract. In this embodiment, the strut **24** and elastomeric filament **23** of **FIG. 1** may be replaced with a spring. Or alternatively, the strut **24** may be shortened and a spring **15** added to the end being inserted into the outer casing **2**. The casings (**2, 4**) may then be filled with a medicine or drug and then the casings compressed together and inserted into a digestible

outer capsule **10** of such dimensions so as to keep the gastrointestinal sampling device **1A** in its closed and sealed configuration. The outer capsule **10** may be constructed of such a material and construction that the patient's digestion causes the outer capsule **10** to fail at an expected area of the digestive track, releasing the payload substance as the spring **15** forces the gastrointestinal sampling device **1A** into its open configuration. Non-limiting exemplary payloads may be any of medicines, chemical substances, enzymes, antibiotics, proteins, fecal matter, fecal transplants, and microbes.

[0064] An exemplary technique using a coordinated set of gastrointestinal sampling devices **1** and **1A** may include two sampling device **1** and one delivery device **1A** being ingested at the same time with slightly different-to dissolution time settings built into the material of the outer capsules **10**. The three devices should travel relatively close together through the digestive tract. Timing differences may be constructed into each capsule such that a first sampling device **1** triggers into its closed configuration capturing a "before" sample. A specified time later the delivery device **1A** triggers into its open configuration to release a medicine. And, at a third time the second sampling device **1** triggers into its closed configuration to take a second sample of the material that should still be in the proximity of the first sample.

[0065] While at least one exemplary embodiment has been presented in the foregoing detailed description of the invention, it should be appreciated that a vast number of variations exist. It should also be appreciated that the exemplary embodiment or exemplary embodiments are only examples, and are not intended to limit the scope, applicability, or configuration of the invention in any way. Rather, the foregoing detailed description will provide those skilled in the art with a convenient road map for implementing an exemplary embodiment of the invention. It being understood that various changes may be made in the function and arrangement of elements described in an exemplary embodiment without departing from the scope of the invention as set forth in the appended claims.

What is claimed is:

1. A sampling system comprising:
an inner capsule further comprising,
a ported first casing with an open end, a closed end, an inner surface, and an outer surface,
a ported second casing with an open end, a closed end, an inner surface, and an outer surface,
a hydrophobic, acid resistant elastomeric filament fixedly attached to the closed end of the ported first casing and to the closed end of the ported second casing, and
a hydrophilic strut, wherein the hydrophilic strut spaces the closed end of the ported first casing away from the closed end of the ported second casing and is of such a length as to impart a tension in the hydrophobic elastomeric filament; and
a first digestible outer capsule enveloping the inner capsule, the first digestible outer capsule being configured to temporarily isolate the inner capsule from bodily fluids.
2. The sampling system of claim 1, wherein the outer surface of the open end of one of the ported first casing and the ported second casing slideably engages the inner surface of the open end of the other ported casing permitting a sliding transition of the inner capsule from an open configuration to a closed configuration.
3. The sampling system of claim 2, wherein in the closed configuration the inner capsule is fluid tight.
4. The sampling system of claim 2 further comprising a slide ring stop circumscribing the inner surface of one of the ported first casing and the ported second casing, wherein the slide ring stop is configured to engage the outer surface of the other ported casing when the inner capsule is in the closed configuration thereby arresting any further sliding transition thereof.
5. The sampling system of claim 4, wherein the hydrophobic elastomeric filament applies a contracting force that holds the outer surface of the other ported casing against the slide ring when the inner casing is in its closed configuration.
6. The sampling system of claim 2, wherein the hydrophobic elastomeric filament provides a

contracting force between the ported first casing and the ported second casing when the inner capsule is in either of the closed configuration or in the open configuration.

7. The sampling system of claim 1, wherein the hydrophilic strut is one of an immediate action strut and a delayed action strut.

8. The Sampling system of claim 1 further comprising a second digestible outer capsule that envelops the inner capsule and is enveloped by the first digestible capsule, wherein the second digestible capsule is formulated to fail based on different environmental factors than the first digestible capsule.

9. A gastrointestinal sampling device comprising:

a hollow capsule having a ported inner casing with a closed end and an open end and having a ported outer casing with a closed end and an open end;

an elastomeric filament fixedly securing the closed end of the inner casing to the closed end of the outer casing; and

a hydrophilic strut spacing the closed end of the inner casing away from the closed end of the outer casing when intact.

10. The sampling device of claim 9, wherein the open end of the outer casing envelopes the open end of the inner casing leaving all ports unobstructed in an open configuration as long as the hydrophilic strut is structurally intact.

11. The sampling device of claim 9, wherein the open end of the outer casing envelopes the open end of the inner casing and fluidly blocks all ports of the inner casing and the open end of the inner casing fluidly blocks all ports of the outer casing when the hydrophilic strut has structurally failed resulting in the sampling device sliding into in a closed configuration.

12. The sampling device of claim 9, wherein the hydrophilic strut has a length sufficient to place the sampling device in the open configuration and also inducing a first tension in the elastomeric filament.

13. The sampling device of claim 11, further comprising a slide ring stop circumscribing an inner surface of the outer casing, wherein the slide ring stop is configured to engage the ported inner casing thereby defining the closed condition, wherein further in the closed condition the elastomeric filament has a second tension.
14. The sampling device of claim 9, wherein the delayed hydrophilic strut comprises two or more hydrophobic members temporality attached together by a hydrophilic attachment means to form the strut.
15. The Sampling device of claim 9, wherein the length of the elastomeric filament always applies a closing force between the ported inner casing and the ported outer casing.
16. A gastrointestinal sampling system comprising:
 - a hollow capsule having a ported inner casing having a closed end and an open end slidingly engaged within a ported outer casing also having a closed end and an open end; and
 - an elastomeric filament fixedly securing the closed end of the inner casing to the closed end of the outer casing.
17. The gastrointestinal sampling system of claim 16 further comprising a hydrophilic strut spacing apart the closed end of the ported inner casing from the closed end of the ported outer casing, thereby imparting a tension in the hydrophobic elastomeric filament.
18. The gastrointestinal sampling system of claim 17 further comprising a fluid tight enteric outer casing enveloping the hollow capsule.
19. The gastrointestinal sampling system of claim 16, wherein the hollow capsule includes a radio frequency ID (RFID) device uniquely identifying the capsule.
20. The gastrointestinal sampling system of claim 19, wherein a circuit of the RFID device is configured to detect and report when queried whether the hollow capsule is in an open configuration or a closed configuration.

21. A gastrointestinal sampling system comprising:

an ingestible means for obtaining and containing a sample of gastrointestinal microbiota and content;

a means for temporarily maintaining the ingestible means for obtaining and containing a sample of gastrointestinal microbiota and content in an open configuration; and

a means for collapsing the ingestible means for obtaining and containing a sample of gastrointestinal microbiota and content into a closed configuration after obtaining the sample.

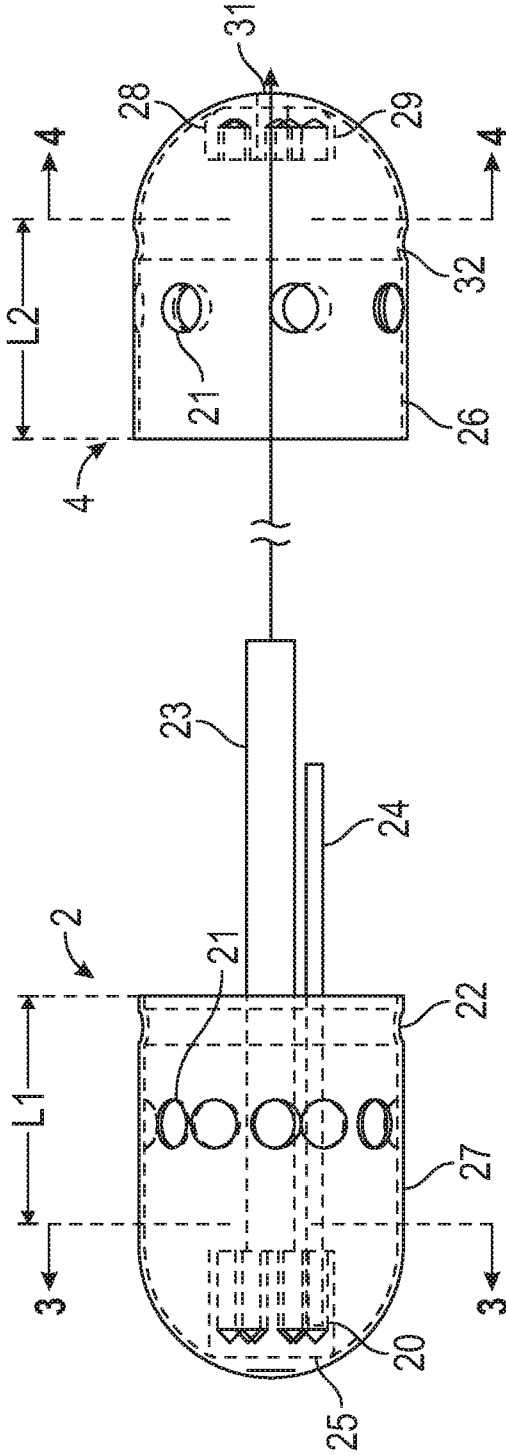

FIG. 1

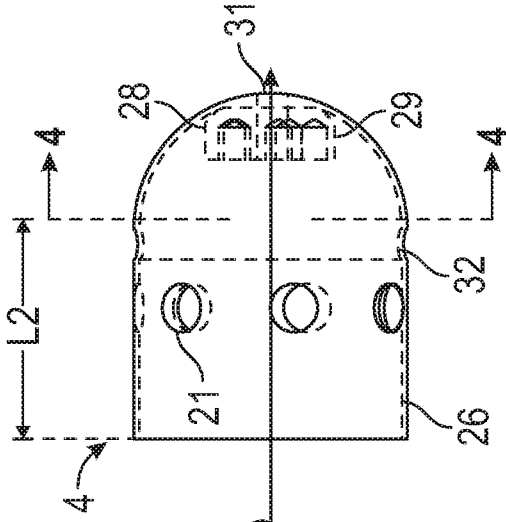

FIG. 2

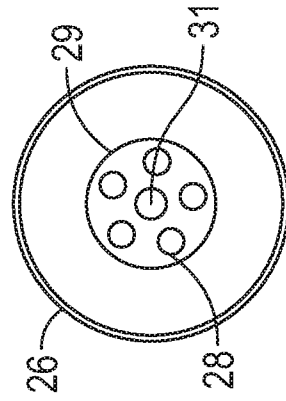

FIG. 3

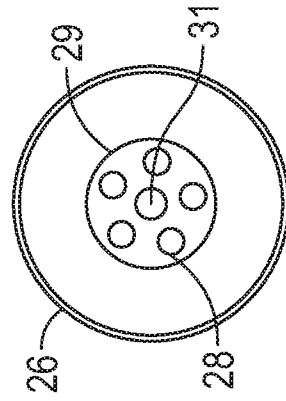

FIG. 4

2/6

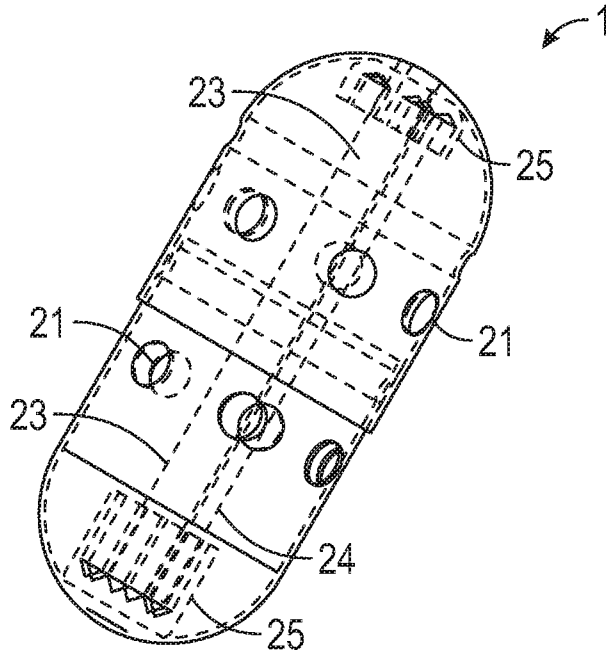

FIG. 5

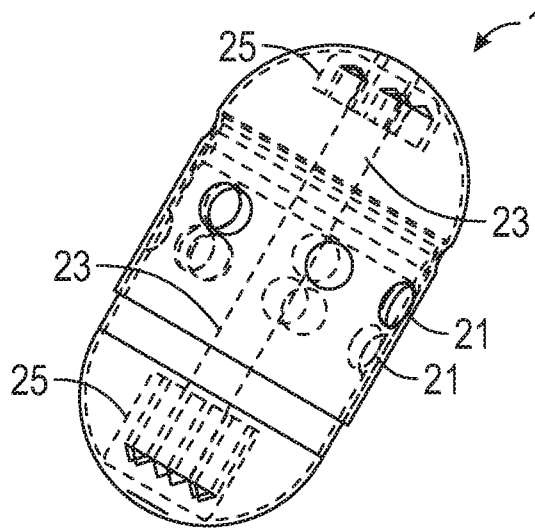

FIG. 6

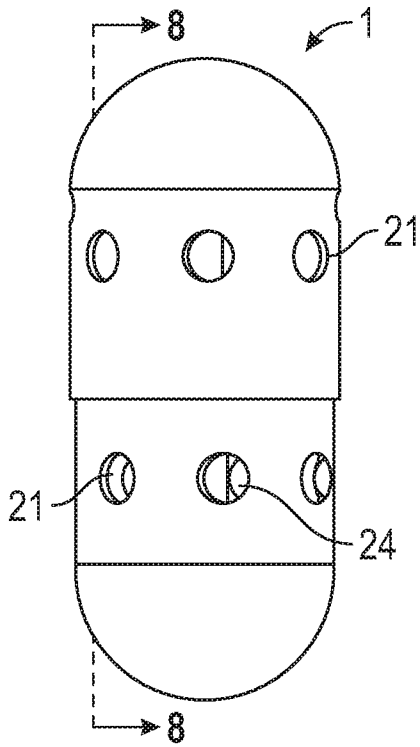

FIG. 7

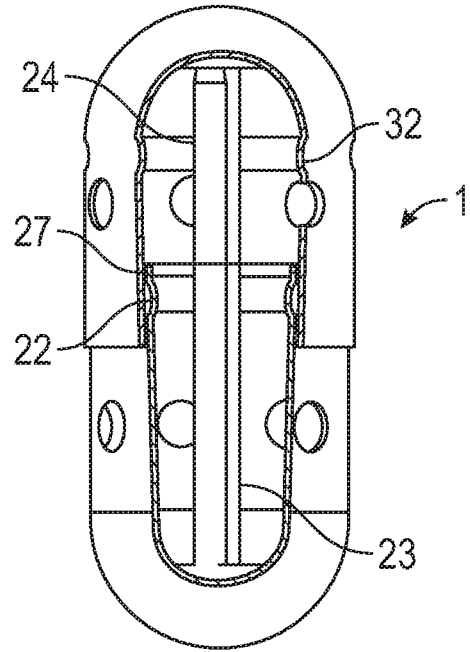

FIG. 8

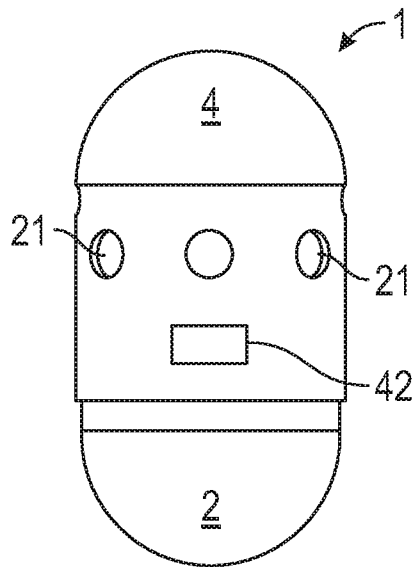

FIG. 9

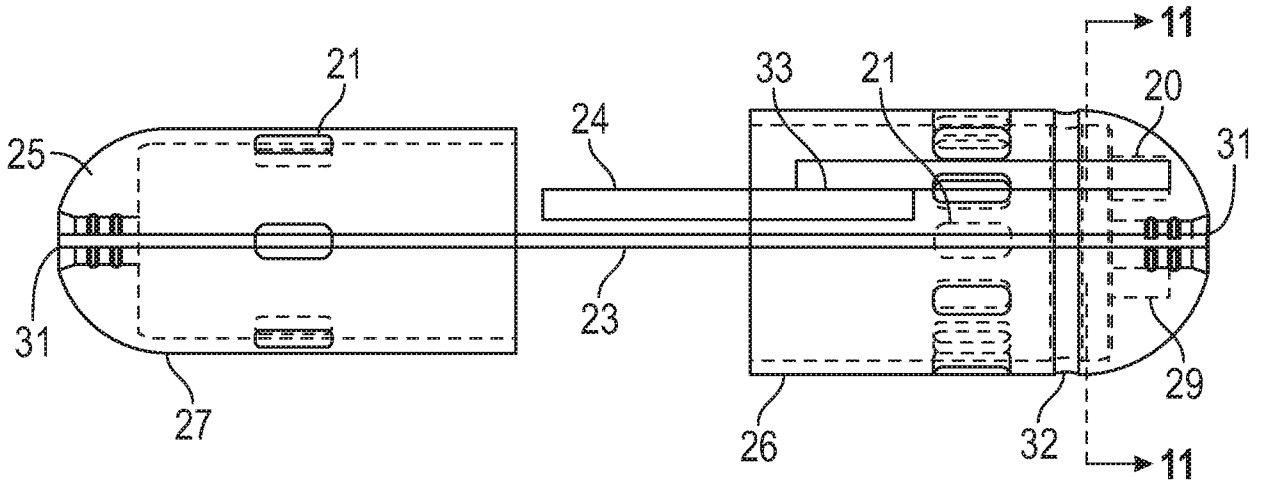

FIG. 10

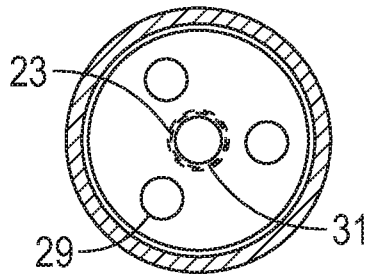

FIG. 11

5/6

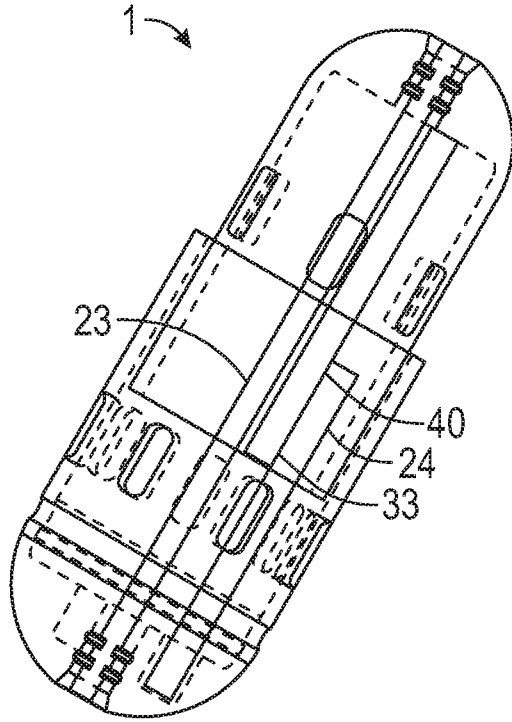

FIG. 12

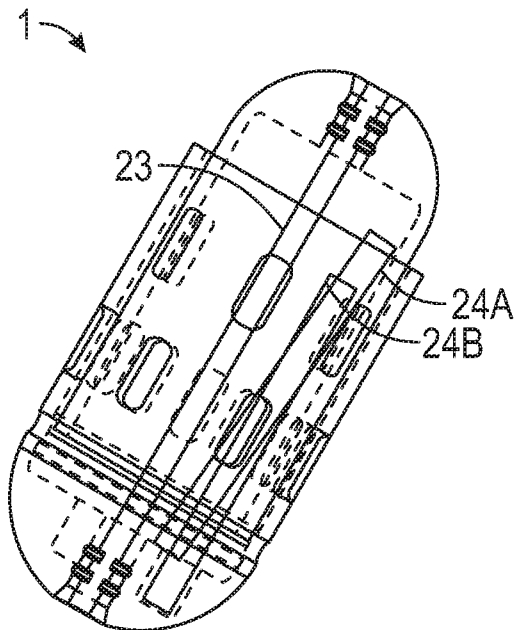

FIG. 13

6/6

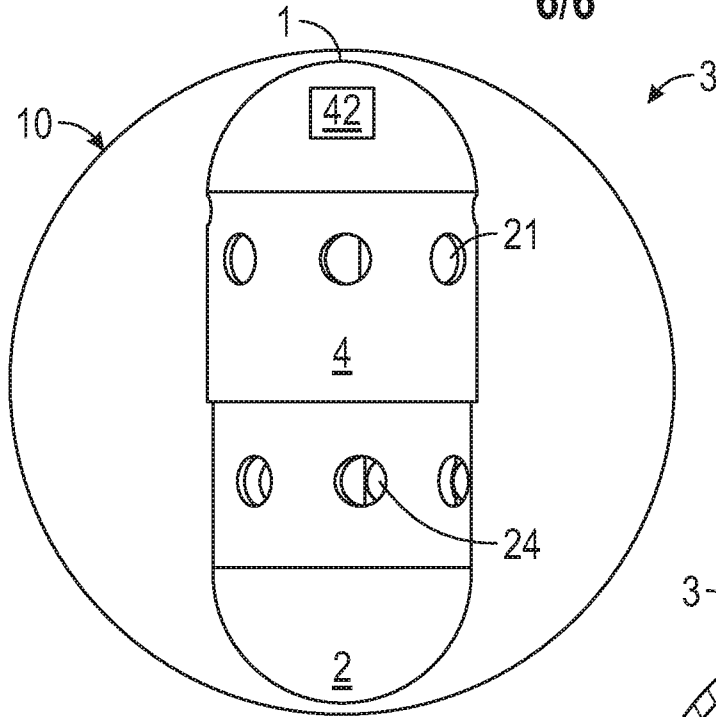

FIG. 14

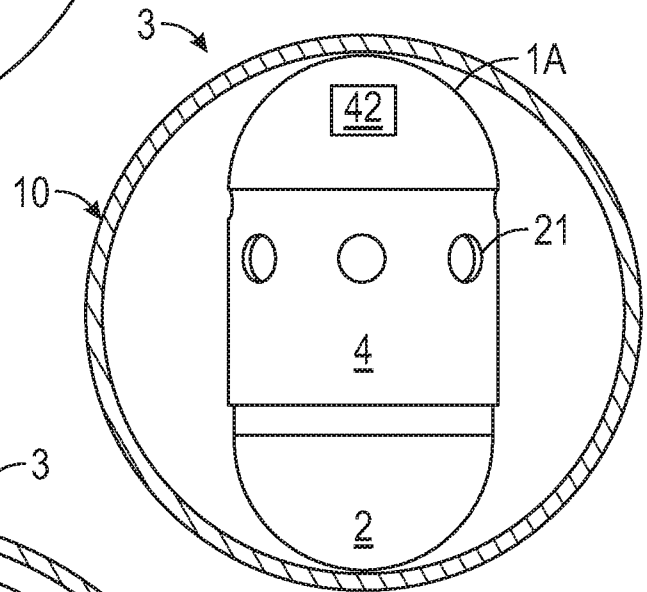

FIG. 15

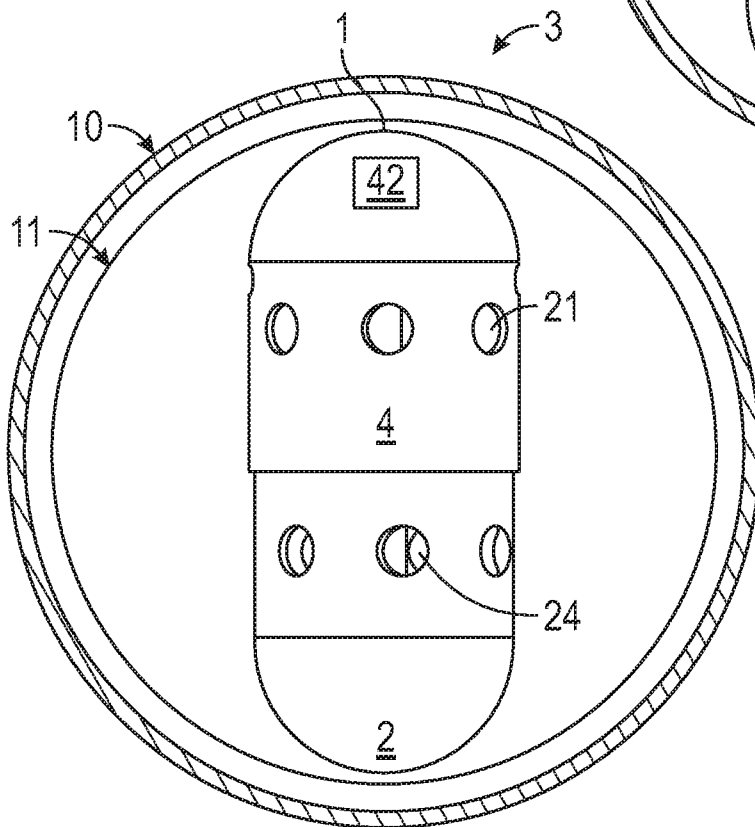

FIG. 16

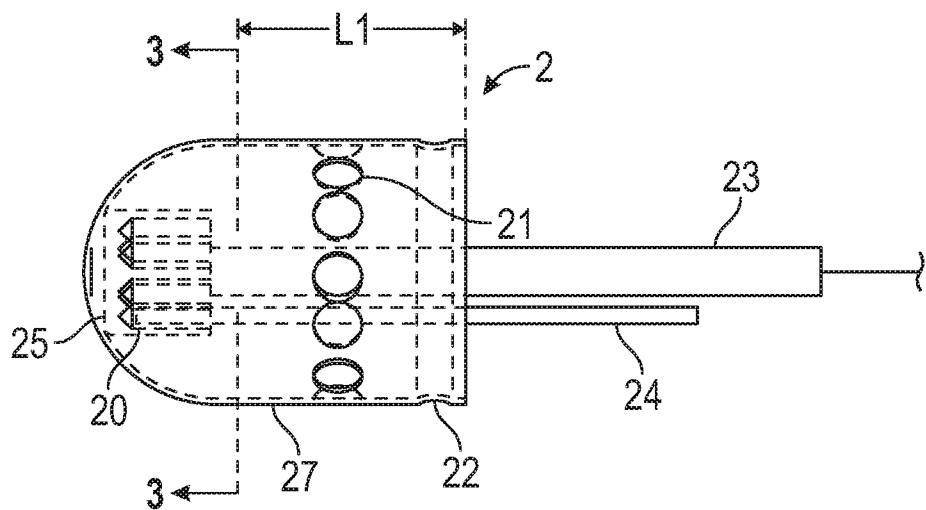

FIG. 1