

March 29, 1932.

LE ROI E. HUTCHINGS

1,851,581

PAPER FILE

Filed June 15, 1928

2 Sheets-Sheet 1

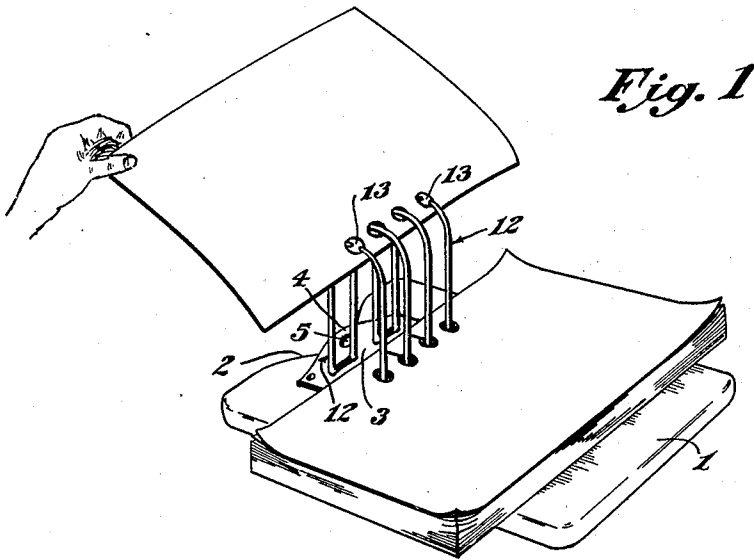
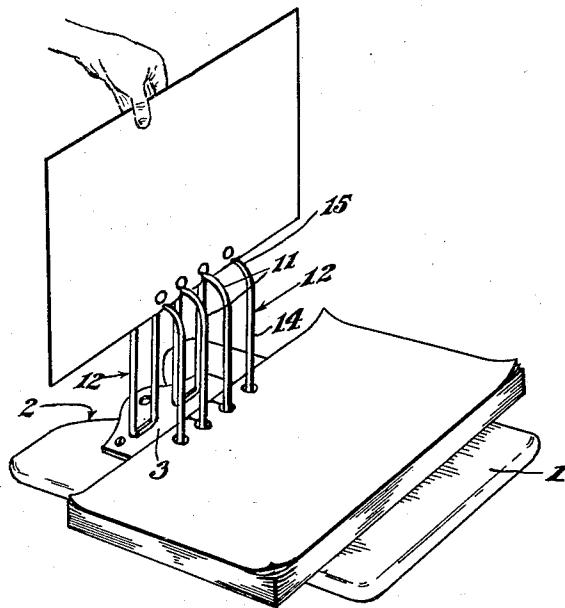

Fig. 1

Fig. 2



Inventor
Le Roi E. Hutchings
by Barton A. Beard
Attorney

March 29, 1932.

LE ROI E. HUTCHINGS

1,851,581

PAPER FILE

Filed June 15, 1928

2 Sheets-Sheet 2

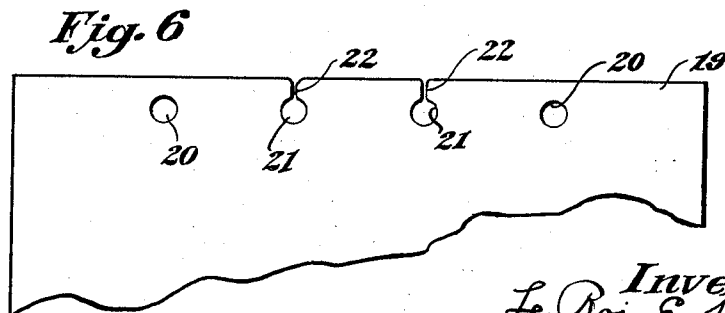
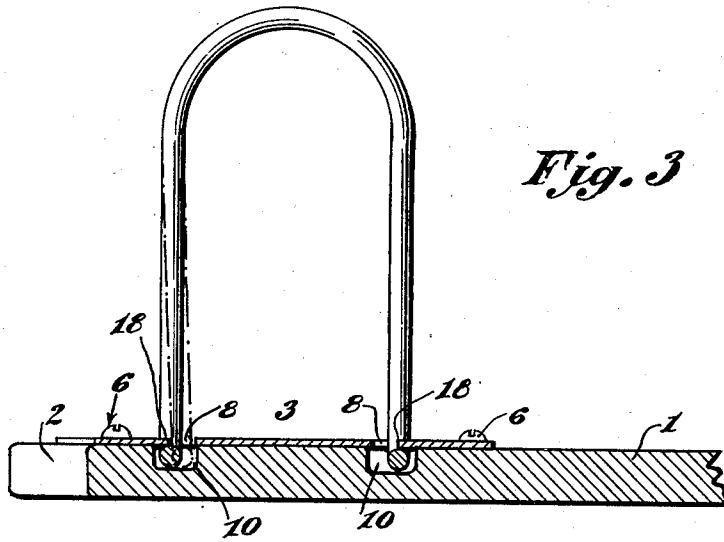
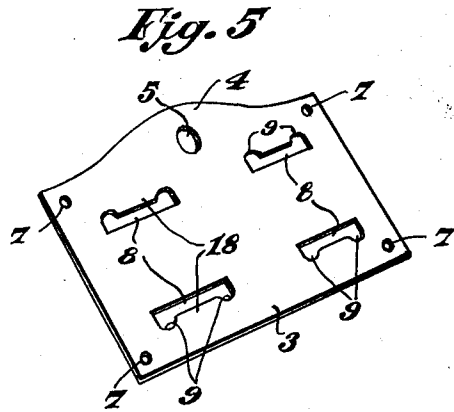
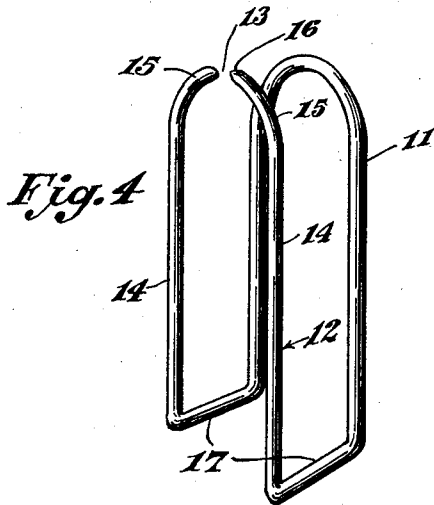

Inventor
Le Roi E. Hutchings
by Barton A. Beau Jr.
Attorney

UNITED STATES PATENT OFFICE

LE ROI E. HUTCHINGS, OF BUFFALO, NEW YORK, ASSIGNOR TO REMINGTON RAND INC.,
OF TONAWANDA, NEW YORK

PAPER FILE

Application filed June 15, 1928. Serial No. 285,659.

This invention relates to improvements in paper files and particularly to the type of file having a supporting plate, at one end portion of which is mounted a plurality of suitable leaf-supporting and retaining structures which project laterally from the face of the supporting plate.

This invention is designed to provide a paper file in which the leaf-retaining structures are detachably engaged in interlocked relation with the supporting plate so that they may be removed from the supporting plate when it is desired to transfer the filed papers from a temporary to a permanent file or the like, or when it may be desired to store the same. This permits the use of the supporting plate for the reception of other files by the engagement of other similar leaf-retaining structures therewith, so that the supporting plates are always in use in active files.

Another object of the invention resides in the provision of a special construction for the leaf-retaining structures for detachably supporting leaves in such a manner that they may be readily moved from one end of the retaining structures to the other, in which movement, the formation of the sheets effectively cooperate with the retaining structures to prevent detachment of the sheets therefrom, and in which the retaining structures and sheets are so formed that the sheets may be readily attached or detached in one position thereof relative to the retaining structures.

A further object of the invention resides in providing a paper file in which a plurality of substantially U-shaped retaining structures are provided, some of which are imperforate while others are provided with gaps intermediate the ends adapted to have special cooperation with specially formed sheets to permit attachment and detachment of the sheets with the retaining structures at the portions aligned with gaps, and wherein the sheets and retaining structures normally cooperate to prevent detachment of the sheets from the retaining structures in their movement from one end of the retaining structures to the other as they pass over the gaps in some of said structures.

The invention also comprehends the provision of specially constructed units formed of single lengths of wire to provide a pair of leaf-retaining structures of U-shaped construction, normally inverted and in which one of the structures is an integral or imperforate member while the other is provided with a gap intermediate its ends formed by the opposed ends of the wire forming the structures, intermediate portions of the wire being adapted for interlocking cooperation with a suitable retaining plate carried by the supporting member for the file.

The invention includes numerous other objects and advantages which reside in the special construction and association of the several parts, which are all more particularly pointed out in detail in the following description and claims, directed to a preferred form of construction, it being understood, however, that various changes may be made in the construction, relation and assembly of the parts without departing from the features of the invention as set forth in the following description and claims.

In the drawings forming part of this application:

Fig. 1 is a perspective of the improved paper file illustrating how a sheet is moved from one side of the file to the other and effectively guided across the gap portions of some of the retaining structures without detachment therefrom.

Fig. 2 is a perspective similar to Fig. 1, but illustrating the method of operating a sheet to detach the same from the retaining structures.

Fig. 3 is a vertical longitudinal section through one of the leaf-retaining structures.

Fig. 4 is a perspective showing the construction of one pair of dissimilar leaf-retaining structures from a single length of wire.

Fig. 5 is a perspective of the retaining plate for the leaf retaining structures.

Fig. 6 is a plan view of one end portion of one of the sheets for the file, showing the formation of the apertures therein which receive the file-retaining structures.

This improved file includes a supporting

plate or base member 1 which may be made of wood, metal or any suitable material found most desirable for the purpose. This supporting plate forms the main support for the handling of the entire file and the supported sheets in the ordinary use thereof. One end of this supporting plate is provided with a V-shaped recess 2, and a retaining plate 3 is mounted on this end of the supporting plate so that the projecting portion 4 of the retaining plate formed with the opening 5 therein will over-lie the recess 2. This provides a means by which the entire file may be hung up on a wall, the side of a desk, or the like, by engaging the plate 3 with a suitable prong or nail projecting through the opening 5. The plate 3 is secured to the supporting plate in any suitable manner such as by screws 6 inserted through the openings 7 at the corner portions thereof, while the central portion of this retaining plate is provided with pairs of slots 8 having enlargements or laterally extending portions 9 at the opposite ends, the enlargements 9 of one slot extending in opposite directions to the enlargements of the other slot of each pair, as clearly illustrated in Fig. 5. The supporting plate 1 is recessed at 10, as shown in Fig. 3, in registry with the pairs of slots 8, the recess 10 being substantially wider than the slots in the retaining plate.

In the file illustrated, four inverted U-shaped leaf supporting structures are provided, as shown in Figs. 1 and 2, which are mounted in spaced parallel relation and in alignment transversely with respect to one another. The two central leaf-supporting structures indicated at 11 are continuous members so as to provide a pair of continuous supporting rods for sheets attached thereto. The outside leaf-supporting structures, indicated at 12 in Figs. 1 and 2, are formed to provide gaps 13 substantially equidistant from the ends thereof. The U-shaped retaining structures 12 each comprise a pair of parallel prong sections 14 having the free ends 15 curved toward each other and terminating in opposed relation. The ends are in substantial alignment and are preferably formed of ogival shape, as indicated at 16 in Fig. 4, to facilitate the ready engagement and disengagement thereof in the openings in a paper sheet without the likelihood of tearing the sheet.

Each of the U-shaped leaf-retaining structures, as shown in Figs. 1 and 2, terminating at the retaining plate 3 and is suitably secured thereto. The preferred form of constructing these leaf-retaining structures is shown in Figs. 3 and 4 which provides for the formation of one of the continuous structures 11 with one of the structures 12 to form an integral unit. This is done by forming one of the members 11 and one of the structures 12 from a single piece of wire of suit-

able size and rigidity so that the ends of the wire terminate in adjacent spaced relation intermediate the prongs 14 of the structure 12 to provide the gap 13. Intermediate sections of the wire 17 join the ends of the U-shaped portions 11 and 12 and support each pair of dissimilar leaf-retaining structures in their proper spaced relation.

This form of construction permits of the detachable mounting of the leaf-retaining units in the retaining plate 3 through the special formation of the slots in the plate so that the ends of the retaining structures with the connecting portions 17 can be inserted through one pair of slots by flexing these portions 17 toward one another, as shown in dot and dash lines in Fig. 3. When the portions 17 are received within the recess 10 of the supporting plate, they may be released from the flexed position under tension, following which the resiliency of the wire will spring the ends apart so that the end portions of each structure will seat in the outwardly extending enlargements 9 of each pair of slots while the connecting portions 17 will engage under the intervening portions 18 of the retaining plate with which they will have interlocking cooperation to rigidly mount the leaf-retaining structures in the retaining plate and on the supporting member to project laterally therefrom in the manner illustrated in Figs. 1 and 2.

A special form of sheet is obviously required for this file which is illustrated in detail in Fig. 6 at 19. One marginal portion of this sheet has a series of aligned apertures 20 and 21 at proper spaced intervals to receive the four leaf-retaining structures of the file. The central openings 21 have a slot 22 formed in the marginal portion of the sheet communicating therewith, which also extend through the edge of the sheet. This permits of the insertion of the sheet on to the central pair of leaf-retaining structures 11 so that they will be received in the openings 21 in such a manner that the sheet will be freely slidable along these structures.

To apply the sheets to the file, they are inserted transversely of the leaf-retaining structures at the center thereof as shown in Fig. 2, so that the margin formed with the openings can be engaged through the gaps 13 in the end structures 12, while the center portion of the sheet receives the central structures 11 through the slots 22 into the apertures 21. Then, the sheet may be moved to either end of the leaf-retaining structures as desired and may be supported thereby on the supporting plate 1 as clearly shown in Figs. 1 and 2.

In the use of the file, the sheets may be turned from the superposed position of one upon the other, shown in Fig. 1, to the opposite ends of the leaf-retaining structures so as to expose the surface of a desired sheet

for recording thereon or obtaining access to a record thereon by grasping the free margin of the sheet in the central portion and with a semi-circular movement of the hand through an arc of 180°, the sheet will slide along all of the retaining structures to the opposite ends thereof. In this movement, the portion of the sheet engaged with the retaining structures will follow the movement of the hand, and as the gaps 13 in the outer structures 12 are approached, the effective guiding and retaining cooperation of the sheet with the structures 11 will flex the sheet slightly in this following action so as to hold the openings 20 in position to receive the ends 15 at the opposite side of the gap and as a result of this the sheet will move freely around the central curved portion of the retaining structures without becoming disengaged or catching on the ends 15.

When it is desired to remove a sheet from a file, it is grasped at the free margin and a direct upward motion is made so as to raise the sheet upwardly at right-angles to the central curved portions of the retaining structures, as illustrated in Fig. 2, which will draw the sheet to the portions of the structures 12 providing the gaps 13, and with the aligning of the marginal portion of the sheet with the gaps a slight additional pull will serve to disengage the structures 11 from the sheet through the slots 22. This operation of the sheets to move them from one side of the file to the other or to disengage them from the file, materially facilitates the working of the same and the sheets operate in an unusually easy manner over the leaf-retaining structures and in an unusually efficient manner.

When a group of papers are filed on the leaf-retaining structure units, they may be readily disengaged in group form from the supporting plate 1 without removal from the leaf-retaining structure units by disengaging the retaining structure units from the retaining plate 3 through the slight flexing of the ends toward one another so that the connecting portions 17 may be withdrawn through the slots 8. The detached group including the units may then be stored or boxed for transportation or transferred to some other type of holder construction which may be used for inactive files without disassembling the sheets from their filed order, while the supporting plate may have a new set of leaf-retaining structure units engaged therein for receiving new sheets for filing.

It should be understood from the above description that the invention provides a portable file holder in which the papers are efficiently retained, including a specially constructed sheet, special leaf-retaining structures and a specially constructed supporting structure for the leaf-retaining structures in which the sheets, the leaf-retaining structures

and the supporting structure therefor each cooperate one with the other to provide a highly novel and useful file adapted to supply numerous requirements for the convenient handling of groups of papers.

What is claimed is:

1. A paper file, comprising a pair of inverted U-shaped leaf-retaining structures arranged in spaced parallel relation, and cooperating outer leaf-retaining structures arranged on each side of said pair of structures in a plane parallel thereto and in transversely aligned relation therewith, each outer structure comprising a pair of spaced prongs having curved ends terminating in opposed and spaced relation, said ends being substantially ogival-shaped.

2. A paper file, comprising a pair of leaf-retaining structures arranged in spaced parallel relation, one of said leaf-retaining structures being an inverted U-shape, and the other structure consisting of a pair of spaced parallel prongs having the ends curved toward each other and terminating in adjacent aligned and spaced relation.

3. A paper file, comprising a pair of leaf-retaining structures arranged in spaced parallel relation, each structure being of inverted U-shape, and one of said structures having a gap intermediate its ends.

4. A paper file, comprising a pair of inverted U-shaped leaf retaining structures arranged in spaced parallel relation, one of said structures being formed to provide a gap intermediate its ends, and means joining adjacent ends of said structures to form an integral unit.

5. A paper file, comprising a length of wire formed to provide a pair of inverted U-shaped leaf-retaining structures arranged in spaced parallel relation, one of said structures being formed to provide a gap intermediate its ends, said structures having corresponding ends joined by intermediate portions of said wire.

6. In combination, a paper file having a pair of inverted U-shaped leaf-retaining structures, one of said structures being complete and the other structure having a gap intermediate the ends, and a sheet having a pair of apertures in one marginal portion receiving said leaf-retaining structures, the aperture receiving said complete structure having a slot formed in the marginal portion of said sheet communicating therewith, whereby the sheet may be removed from said structures by withdrawing the complete structure through the slot, and the marginal portion of the sheet through the gap in the other structure.

7. In combination, a paper file having a pair of leaf-retaining structures, one of said structures being complete and the other structure having a gap intermediate the ends, and a sheet slidably mounted on said structures

having a pair of apertures, each receiving one of said structures, the aperture receiving said complete structure having a slot formed in the marginal portion of the sheet communicating therewith, said sheet being normally guided in sliding movement from end to end of said file by said structures, said complete structure normally retaining the sheet in the file as it passes the gap of the other structure, and said sheet being removable from said file by withdrawal thereof through the gap in said other structure, the slot permitting removal from said imperforate structure.

8. A paper file, comprising a supporting member having recesses in one face, a plurality of retaining units, each unit consisting of a pair of inverted U-shaped retaining structures having means connecting their corresponding legs, one of the structures in each unit having a slot intermediate its ends, and means for mounting said units on said supporting member with portions of each unit including said connecting means engaging in the recesses in said supporting member, said recesses in said supporting member being spaced to mount said units in spaced aligned and parallel relation with the spacing between all the retaining structures on all the units equal.

LE ROI E. HUTCHINGS.

35

40

45

50

55

60

65