



INTERNATIONAL APPLICATION PUBLISHED UNDER

WO 9606018A1

(51) International Patent Classification⁶ :

B65D 51/24

A1

(11) International Publication Number:

WO 96/06018

(43) International Publication Date:

29 February 1996 (29.02.96)

(21) International Application Number: PCT/US94/11701

(22) International Filing Date: 14 October 1994 (14.10.94)

(30) Priority Data:

08/292,992

19 August 1994 (19.08.94)

US

(71) Applicant: W. L. GORE & ASSOCIATES, INC. [US/US]; 551
Paper Mill Road, P.O. Box 9206, Newark, DE 19714 (US).(72) Inventor: JONES, C., Bradford; 32 Autumnwood Drive,
Newark, De 19717 (US).(74) Agents: SAMUELS, Gary, A. et al.; W. L. Gore & Associates,
Inc., 551 Paper Mill Road, P.O. Box 9206, Newark, DE
19714 (US).(81) Designated States: AT, AU, BB, BG, BR, BY, CA, CH, CN,
CZ, DE, DK, ES, FI, GB, HU, JP, KP, KR, KZ, LK, LU,
LV, MG, MN, MW, NL, NO, NZ, PL, PT, RO, RU, SD,
SE, SK, UA, UZ, VN, European patent (AT, BE, CH, DE,
DK, ES, FR, GB, GR, IE, IT, LU, MC, NL, PT, SE).

Published

With international search report.

(54) Title: VENTED VIAL FOR FREEZE-DRYING AND METHOD OF MINIMIZING CONTAMINATION OF FREEZE-DRIED PRODUCTS

(57) Abstract

The present invention relates to a lyophilization process and a cap (10) intended for vials or use therewith for containers that are subjected to lyophilization conditions where the cap (10), which may be resiliently helped in place or screwed on, includes a plug member (20) movable within a fluid passageway (23) in the cap, the plug member while positioned in the fluid passageway (23) is movable between a first upwardly extending venting position and second downwardly engaging, sealing position whereby fluid from the vial or container is precluded from flowing through the fluid passageway (23) in the cap (10).

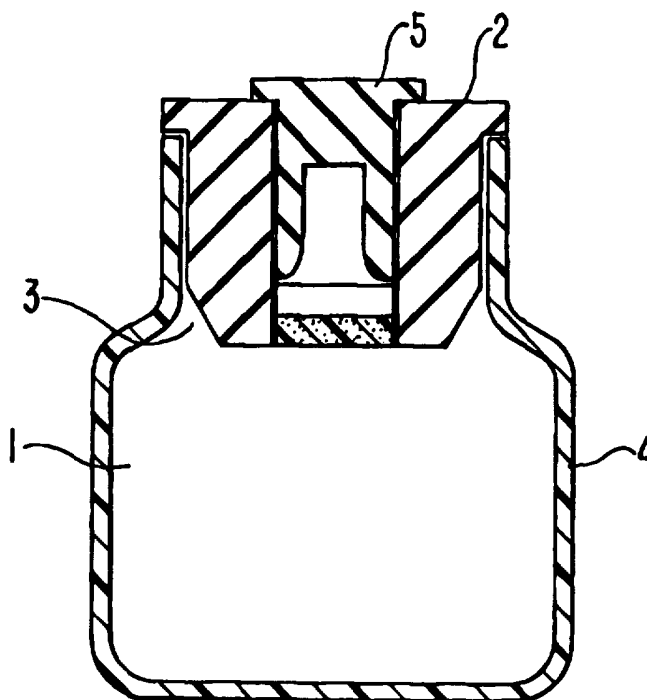

FOR THE PURPOSES OF INFORMATION ONLY

Codes used to identify States party to the PCT on the front pages of pamphlets publishing international applications under the PCT.

| | | | | | |
|----|--------------------------|----|--|----|--------------------------|
| AT | Austria | GB | United Kingdom | MR | Mauritania |
| AU | Australia | GE | Georgia | MW | Malawi |
| BB | Barbados | GN | Guinea | NE | Niger |
| BE | Belgium | GR | Greece | NL | Netherlands |
| BF | Burkina Faso | HU | Hungary | NO | Norway |
| BG | Bulgaria | IE | Ireland | NZ | New Zealand |
| BJ | Benin | IT | Italy | PL | Poland |
| BR | Brazil | JP | Japan | PT | Portugal |
| BY | Belarus | KE | Kenya | RO | Romania |
| CA | Canada | KG | Kyrgystan | RU | Russian Federation |
| CF | Central African Republic | KP | Democratic People's Republic of Korea | SD | Sudan |
| CG | Congo | KR | Republic of Korea | SE | Sweden |
| CH | Switzerland | KZ | Kazakhstan | SI | Slovenia |
| CI | Côte d'Ivoire | LI | Liechtenstein | SK | Slovakia |
| CM | Cameroon | LK | Sri Lanka | SN | Senegal |
| CN | China | LU | Luxembourg | TD | Chad |
| CS | Czechoslovakia | LV | Latvia | TG | Togo |
| CZ | Czech Republic | MC | Monaco | TJ | Tajikistan |
| DE | Germany | MD | Republic of Moldova | TT | Trinidad and Tobago |
| DK | Denmark | MG | Madagascar | UA | Ukraine |
| ES | Spain | ML | Mali | US | United States of America |
| FI | Finland | MN | Mongolia | UZ | Uzbekistan |
| FR | France | | | VN | Viet Nam |
| GA | Gabon | | | | |

TITLE OF THE INVENTION

5 **VENTED VIAL FOR FREEZE-DRYING AND METHOD OF MINIMIZING
CONTAMINATION OF FREEZE-DRIED PRODUCTS**

FIELD OF THE INVENTION

10 This invention relates to a method of freeze-drying and to a cap for
venting a vial in freeze-drying processes. The cap is designed to protect the
contents of the vial from contamination while allowing a path for water vapor to
escape from the vial during the freeze-drying process.

BACKGROUND OF THE INVENTION

15 Freeze-drying is used for the preservation of a wide variety of foods,
pharmaceuticals, and biological products. Extreme care must be taken in
handling and processing many of these products to minimize opportunities for
contamination. For example, freeze-drying equipment is often steam-sterilized
20 between batches, and in many cases the entire operating area in which the
equipment is located may be outfitted as a sterile clean room to minimize the
exposure of products to contaminants as they are being transported to and
from the freeze-dryer. In many cases, products must be re-packaged after
freeze-drying, thus presenting yet another handling step that provides an
25 opportunity to introduce contaminants into the freeze dried product.

30 Many freeze-drying processes involve placing open containers of
material in the freeze-dryer. Containers are kept open until the freeze-drying
process is completed to allow a path for water vapor to be removed from the
product. This practice, however, presents an opportunity for contamination;
hence the concern for cleanliness and sterility of the freeze-drying equipment
and the area surrounding it.

35 Cross-contamination between different batches of product being dried at
the same time is also a problem. Freeze-drying equipment is expensive, and
freeze-drying cycles are generally very long, consuming many hours or even
several days for the processing of a single batch of material. As a result, it is
very common for freeze-dryers to maximize the use of their capital investment
in the equipment by attempting to fully load the freeze-drying chamber every
time it is cycled. This in turn results in the common practice of freeze-drying

- 2 -

different materials in the same chamber at the same time. Since all the materials are in open containers, cross-contamination of product can, and commonly does, occur.

For example, in U.S. Patent No. 3,454,178 to Bender, et al., a vial
5 contains a slotted vial cap that, when in the "up" position, allows a path for water vapor to escape the vial. Vials are introduced into the process with their caps in the "up" position, and remain that way until the drying cycle is complete. At the end of the cycle, freeze-drier shelves squeeze down on the vials and press the caps into the "down" position, thus sealing the vials before
10 the drier door is opened. This approach assures that contents of the vials are not contaminated after the process is complete. It also assures that water vapor cannot enter the vials and rehydrate the product once the drier doors are open; indeed, the vials are often repressurized at the end of the process with a dry inert gas, such as nitrogen, prior to pushing the vial caps into the
15 "down" position, to maximize the shelf life of the freeze-dried product. But the problem of contamination of the vial contents when the vials are being loaded into the drier or during the freeze-dry process itself is not addressed by this patent.

In European Patent No. 343,596, a container that has been designed to
20 protect freeze-dried products from contamination during the freeze-drying process is described. The container has at least one side that includes a hydrophobic, porous, germ-tight, water vapor-permeable membrane. Water vapor can escape the closed container through this porous membrane, while the membrane represents a barrier to contamination. Another technique used,
25 such as that taught in U.S. Patent No. 5,309,649 to Bergmann, involves freeze-drying material in a container that has a porous hydrophobic wall. Neither of these patents, however, addresses the concern about re-hydrating the contents of the container once the doors of the drier are opened. It is not obvious how products freeze-dried in such a container could be kept dry and
30 finally packaged in a vapor-tight container without first exposing the dried product to humidity. Thus, a need exists for a container for freeze-dried products that maintains a well-defined level of protection throughout the entire drying process, as well as providing means for forming a vapor-tight seal on the container before the dryer doors are open.

35

SUMMARY OF THE INVENTION

This invention relates to a vial cap that provides a well-defined degree of protection of the contents of a lyophilization vial throughout the entire life cycle of the vial's contents, from the time the product is introduced into the vial prior to freeze-drying, to the time the vial is ultimately opened by the end-user.

The vial cap of the present invention incorporates a controllable venting port that is protected by a porous sterile barrier venting media. The porous venting media provides a barrier to bacteria and other particulate contamination, while permitting the passage of gasses such as air and water vapor. The cap is designed to fit securely in or about the mouth of the vial so that once in place, it forms a bacterial - resistant seal that provides a well-defined degree of protection for the contents of the vial.

One feature of the cap is that, while it is sealed in place in the throat of a vial, its vent can be opened to permit vapor flow through the venting medium or closed to block vapor flow. Another feature of the invention is that closure of the venting port can be accomplished by simply pressing down on the top of the cap.

These and other purposes of the present invention will become evident from a review of the following description when considered in conjunction with the accompanying drawings.

BRIEF DESCRIPTION OF THE DRAWINGS

Figure 1 shows a cross-section of a vial with a vented cap of the present invention.

Figure 2 shows the vented cap of Figure 1 in open position.

Figure 3 shows the vented cap of Figure 1 in closed position.

Figures 4-6 show a vented cap of the present invention using a finned plug.

Figure 7 shows a vented cap of the present invention using a plug member having an interiorly located venting port.

Figures 8 and 9 show a vented cap of the present invention using a plug member having a surface channel venting port.

Figures 10 and 11 show another embodiment of a vented cap of the present invention.

Figure 12 shows an alternate vented cap of the present invention.

Figure 13 shows a vial with a vented screw cap and vial of the present invention.

DETAILED DESCRIPTION OF THE INVENTION

5

The present invention relates to closures that are used with containers, e.g., bottles, vials, etc., that are subjected to lyophilization processes, wherein the contents of the container are lyophilized. The closure or cap assembly of the present invention includes:

- 10 1. A cap or stopper body that can form a vapor-tight seal with the mouth of a vial or bottle.
2. A venting port that comprises a hole or passage in the cap or stopper and which provides a pathway between the interior of the bottle and the exterior of the bottle
- 15 3. A water vapor permeable, sterile barrier venting media that is placed in the path of vapor travel through the venting port.
4. Means for permitting the venting port to be opened or sealed, and that is activated to be closed by pressing down on the cap or stopper.

20 13. Figure 1 shows a container or vial 1 having a mouth 3, sidewall 4, and a cap or stopper assembly 2, with a movable plug 5. In Figure 1, the mouth 3 has a smaller diameter than sidewall 4. However, the mouth 3 and sidewall 4 can also have the same diameter, or the mouth could be larger than the bottle. The cap or stopper assembly 2 of Figure 1 is described in greater detail in the
25 discussion below relating to Figures 2-9.

In Figure 2, the stopper or cap assembly 10 has a body 11 of resilient material with a cylindrical section 12, a tapered portion 13, and an inner channel or venting port 14. The channel 14 is shown to have a stepped configuration, although other designs are possible, and includes upper end 15
30 and lower end 16. Ends 15 and 16 have respective openings 17 and 18 to respectively receive a plug member 20 and venting media 30.

The plug member 20 is shown in an open venting position in Figure 2 and a closed, non-venting position in Figure 3. In Figures 2 and 3, plug member 20 has two downwardly extending legs 21 and 22 that are spaced
35 apart from one another to provide a passageway or channel 23 for fluids to be vented from the interior of vial 1 (Figure 1) through venting media 30. The outer diameter formed by said downwardly extending legs is sufficiently large so that the plug member 20 may be resiliently maintained in an upper, open

venting position with end 15. Although plug member 20 is shown as having two legs, it is possible to have three or more downwardly extending legs.

5 Porous sterile venting media 30 extends across opening 18. By porous sterile venting media is meant any material that is water vapor permeable, but which provides effective resistance to bacteria penetration. Examples of venting media include papers, non-woven polymer films such as polyolefin, e.g., spun-bonded Tyvek®, and porous polymer membranes such as expanded porous PTFE. It is preferred that the venting media be hydrophobic. By hydrophobic is meant that the media is resistant to
10 penetration by water. Preferably, the materials' resistance to water vapor flow versus effective pore size should also be considered. Pore sizes in the 0.2 to 3.0 micrometer range will yield performance in bacterial challenge tests that are generally associated with "sterile barrier" media. The smaller the pore size, the more reliable the sterile barrier performance. For the aforesaid, porous, stretched PTFE, which has a microstructure of nodes interconnected with fibrils, nominal pore sizes of 0.1 micrometer, or 0.2 or up to 3 or more micrometers are useful. On the other hand, smaller reference pore sizes in a given material will also yield higher resistance to vapor flow, which can affect productivity in lyophilization. Stretched, porous PTFE is a preferred venting
15 media based on its superior combination of hydrophobicity and water vapor flow for a given nominal pore size.

While the venting media is shown to be located within the opening 18, it is also contemplated to affix the peripheral edge of the venting media to the bottom most edge of tapered portion 13.

25 The operation of the device of Figures 1-3 is as follows. Stopper 10 is inserted into the mouth of the vial and provides a barrier against contamination of the vial contents from bacteria or other particulate contamination from the outside. It also prevents the loss of particulates and their contamination from inside the vial. As shown in Figure 2, when the plug is in the "up" position, the channel slot or passageway 23 in plug 20 presents a path for vapors to enter or leave the vial. When plug 20 is pressed into the "down" position, Figure 3,
30 it seals the vent port, thus prohibiting further passage of particulates, water vapor or other gases into or out of the vial.

Figures 4-9 depict caps that differ from that of Figures 2 and 3 in design. In Figures 4-6, plug member 17' is supported on rigid vanes 41, 42, 43 and 44
35 that allow plug 17' to ride up and down in channel or venting port 14. Figure 4 shows plug member 17' in the "up" position for venting whereby vapor can travel throughout channel 14 around the vanes 41-44.

Figure 5 shows plug member 17' in the down non-venting position. Figure 6 shows a bottom view of plug member 17' with vanes 41-44.

5 In Figure 7, the plug member 17" has a passage 50 that opens at the bottom 51, runs up part of the length 52 of plug member 17", and exits the side of the plug member 17" via side exit or port 54. Again, when the plug is in the "up" position (Figure 7), vapor can travel through passage 50; when the plug member 17" is pressed down, the side exit or port 54 of passage 54 is blocked off and the port 54 is closed.

10 In Figures 8-9, the plug member 17"" has a slot 60 in its side 61 that permits vapor flow when the top 62 of the slot 60 is exposed above the top of assembly cap 2.

15 Figures 10-11 show an alternate embodiment wherein vial 1 uses plug member 70 to vent or close the mouth of the vial 1. Plug member 70 is a stopper that is open at its bottom portion 71. A sterile venting media 72 is wrapped around the circumference of the stopper. The entire plug 70 moves up and down within the neck of the vial. O-rings 73 at the bottom portion of the plug 70, or base of the stopper, seal the plug in the neck of the vial or bottle when the plug 70 is in the "up" or "venting" position. Figure 11 is a bottom view of the plug member 17"".

20 In operation, when plug member 70 is in its elevated position as shown in Figure 10, vapor escapes from the bottle by travelling up the hollow bottom 71 of the stopper and out through the sides through the venting media 72. When the stopper is pressed down, the solid top 74 of the stopper seals the vial completely.

25 Figure 12 shows a plug or stopper 80 with the sterile barrier venting media 81 in the form of a disk that covers the bottom of the hollow stopper. When the stopper 80 is in the "up" position, vapor can move up through the disk 81, into the hollow stopper, and out the hole 82 in the side of the stopper. When the stopper is pressed down into the bottle, all vapor flow is blocked.

30 Figure 13 depicts a screw-on cap 90 for a lyophilization vial. The cap 90 has a stopper or plug 91, a flow through channel 92, venting media disk 93 (similar to venting media 30), gasket 94 and threads 95 to engage the complementary threads on the vial. In the Figure 13, vapor escapes through vent disk 93 in the cap when the stopper in the top of the cap is in the "up" position. When the stopper is pressed down, the system is completely sealed.

35 It can be seen that there are a number of other specific configurations that could be conceived that would remain within the scope or spirit of this invention. Likewise, there are a wide variety of stopper or cap materials that

may be used. A key consideration is the materials' ability to resist moisture penetration or retention, and to maintain an excellent vaporproof seal over a wide range of temperatures. Stoppers or seals of butyl rubber have provided excellent performance.

5 As indicated in the figures, there are a wide variety of configurations of vent ports, venting media, vent port stoppers, plugs, and caps that may be used that would remain within the scope of this invention.

An exemplary process for using the vented vial cap of the subject invention includes, but is not limited to:

- 10 (a) filling the vial or bottle with product under sterile conditions;
 (b) inserting the vented cap or stopper of the present invention into or onto the mouth of the bottle with the vent plug in the "open" position;
 (c) freeze-drying the product in the vial, allowing the water vapor to escape through the venting media and the vent port;
15 (d) optionally re-pressurizing the chamber and the vial with a dry, inert gas such as nitrogen; and
 (e) sealing the vent port by pressing down on the stopper.

EXAMPLE 1

20 Venting Media Tests

To demonstrate that stretched, porous PTFE membranes in the 0.2 micron to 3.0 micrometers reference pore size range could provide an effective barrier to cross-contamination between vials, the following three
25 experiments were run:

Liquid challenge test

In some cases, the membrane might be challenged by contaminated liquid. For example, if a liquid pharmaceutical vial tips over before it is frozen.
30 To demonstrate that the vented vial could retain contaminants in the liquid under such conditions, a liquid challenge test was devised.

In the test, sample membranes obtained from W. L. Gore & Associates, Inc. were challenged with a suspension of ϕ X174 bacteriophage, one of the smallest known viruses, in tryptone broth. Challenge concentration was
35 maintained at at least 100 million PFU/ml. Sterile membrane was contacted with the challenge suspension for 5 minutes at atmospheric pressure; the pressure on the challenge side was then slowly increased to a pressure below the water entry pressure of the membrane sample (as indicated in Table 1),

-8-

and then held constant for an additional 5 minutes. The reverse side of the membranes were then rinsed and assayed for ϕ X174. No virus breakthrough was detected.

5

TABLE 1

| Reference Pore Size | Test Pressure | Challenge Titer (PFU/ml.) | Assay Titer (PFU/ml.) |
|---------------------|---------------|---------------------------|-----------------------|
| 0.2 | 20 psig | 1.8×10^8 | 0 |
| 0.45 | 20 psig | 1.4×10^8 | 0 |
| 1.0 | 15 psig | 1.4×10^8 | 0 |
| 3.0 | 2 psig | 1.4×10^8 | 0 |

Particle challenge test

10 Another possible scenario is that, during drying, very small particles of freeze-dried material could be entrained by vapor evolving below them in the vial and be drawn out of the vial in that manner (this is quite common in freeze-dry processes). To demonstrate that the vented vial could present a barrier to contaminants being carried under this condition, a dry particle filtration challenge test was devised.

15 Salt particles were generated by air drying a finely atomized mist of salt water; the membranes were challenged with an air flow carrying these particles and the particles that penetrated were counted in the downstream air flow by redundant laser particle counters. Air velocity at the membrane surface was > 2 meters/minute. Results of this filtration efficiency test are
20 shown in Table 2.

TABLE 2
Filtration Efficiency of Sample Membranes

| Particle Size (μ) | Reference Pore Size of Membrane | | | |
|-------------------------|---------------------------------|-------------|-------------|-------------|
| | 0.2 | 0.45 | 1.0 | 3.0 |
| 0.10 - 0.12 | 100.000000% | 99.999977% | 99.999954% | 99.999892% |
| 0.12 - 0.15 | 100.000000% | 99.999985% | 99.999985% | 99.999926% |
| 0.15 - 0.20 | 100.000000% | 99.999985% | 99.999985% | 99.999936% |
| 0.20 - 0.25 | 100.000000% | 100.000000% | 100.000000% | 99.999936% |
| 0.25 - 0.35 | 100.000000% | 100.000000% | 100.000000% | 99.999931% |
| 0.35 - 0.45 | 100.000000% | 100.000000% | 100.000000% | 100.000000% |
| 0.45 - 0.60 | 100.000000% | 100.000000% | 100.000000% | 100.000000% |
| 0.60 - 0.75 | 100.000000% | 100.000000% | 100.000000% | 100.000000% |
| 0.75 - 1.00 | 100.000000% | 100.000000% | 100.000000% | 100.000000% |

5 This is a demonstration of the fact that the millions of very fine fibrils in expanded porous PTFE is a unique structure providing very high air filtration efficiencies through the mechanisms of impaction, interception, and diffusion within the membrane.

10 **Aerosol Challenge test**

 While it is undesirable in the freeze dry process, it can be imagined that under certain conditions liquid might form on the membrane or in the vial during the freeze dry process, and small droplets might be entrained by the evolving vapors. Contamination could be carried in these droplets out through
 15 the vent port. To demonstrate that the vented vial could provide a barrier to contaminants that are carried in a fine spray of liquid, the membranes were subjected to a viral filtration efficiency test, a test that is commonly used in testing packaging for sterile medical devices such as disposable surgical
 instruments or implants.

20 In this test, ϕ X174 bacteriophage stock suspension was pumped through a "Chicago" nebulizer at a controlled flow rate and fixed air pressure to form aerosol droplets with a mean particle size of 2.9 microns. The air flow carrying the droplets was driven through the membrane samples and then into a six stage "viable particle" Andersen sampler, which impinges the aerosol droplets
 25 onto one of six agar plates based on size. Samples of 0.2, 0.45, 1.0, and 3.0 micron reference pore size membrane were challenged in this test. After the challenges, the agar plates were incubated at 37°C for 4-18 hours. The

-10-

plaques formed by each virus-laden particle were then counted and converted to probable hit values using the published conversion chart of Andersen.

No colonies were detected downstream of any of the membrane samples.

5

EXAMPLE 2

To demonstrate that freeze-drying could be successfully accomplished with this novel vial cap, prototypes of the design shown in Figure 1 were
10 evaluated in a commercial bone tissue bank application. The objective of this application is to reduce moisture content of bone chips to 1-5% by weight.

Vial caps of the design indicated in Figure 1 were fabricated using a 0.2
15 micron reference pore size expanded PTFE membrane as the sterile barrier venting media. The stopper bodies were made of butyl rubber, and they were sized to mate with the vials that were used in a standard lyophilization
process.

The vials and caps were sterilized. Bone chips were placed in the vials, and the caps firmly sealed in the mouth of the vial with the vent port plugs in the "up" position. Thus, as the vials were introduced to the process, the only
20 path available for water vapor to escape from the vials was through the sterile barrier venting media and out the vent port. The vials were then placed in a drier; the door was closed, the temperature was reduced to -80°C, and a vacuum was drawn. The bone was dried in a 14 day cycle, during which time the vent port plugs were in the "up" position so that water vapor could escape.
25 At the end of the cycle, automatic shelf assemblies squeezed down on the cap sealing the plugs and thus sealing the vial under a dry vacuum condition. The drying chamber was then re-pressurized with nitrogen, and then the doors were opened and the sealed vials were removed. With this process, moisture content of the bone chips was reduced to the vicinity of 1 - 5% by weight and
30 maintained at that low level until the vials were re-opened.

CLAIMS:

1. A vial cap intended for use in lyophilization of the vial's contents, which comprises:
 - 5 (a) a cap or stopper body shaped to form a vapor-tight seal with the mouth of the vial or bottle;
 - (b) a venting port that comprises a hole or passage in the cap or stopper body;
 - (c) a water vapor permeable, sterile barrier venting media that is placed in the path of the vapor travel through the venting port;
 - 10 (d) means for permitting the venting port to be opened or closed off that is activated to be closed by pressing down on the cap or stopper assembly.
2. The vial cap of Claim 1 in which the sterile barrier venting media is, additionally, hydrophobic.
- 15 3. The vial cap of Claim 1 in which the sterile barrier venting media is stretched, porous PTFE.
4. The vial cap of Claim 1 in which the means for closing off the venting port is a plug with a slot or hole that forms an air path when the plug is raised, but seals the air path when the plug is lowered.
- 20 5. The vial cap of Claim 1 in which the means for closing off the venting port is a solid plug or closure device that can seal the port by mechanical means when a downward force is applied to it.
6. The vial cap of Claim 1 in which the body of the cap is a stopper that seals the mouth of the vial or bottle by pressing into it.
- 25 7. The vial cap of Claim 1 in which the body of the cap is a screw-on device that seals the mouth of the vial or bottle by screwing down onto it.
8. The vial cap of Claim 6 in which the vent port enters the bottom of the body of the cap, and exits out the side, so that when the cap is only partially inserted in the mouth of the vial, vapor can pass through the port from the interior of the vial to the outside, but when the cap is fully
30 inserted into the mouth of the vial, the vent port no longer provides a path for vapor to move between the interior and the exterior of the vial.
9. A vial cap intended for use in lyophilization of a vial's contents, which comprises:
 - 35 (a) a resilient stopper having a fluid passageway extending therethrough with an inlet end and an upper outlet end, said inlet end adapted to communicate with an interior of a vial to be

- subjected to a lyophilization process, said resilient stopper having an exterior surface for sealing engagement with a mouth of a vial;
- (b) a plug member movable within said fluid passageway, said plug member being movable between a first upwardly extending venting position and second downwardly engaging sealing position whereby in said second position fluid is precluded from flowing through said fluid passageway; and
- (c) water vapor permeable, sterile, barrier venting media located in the path of vapor travel between the interior and exterior of the vial, and being constructed and arranged to provide a barrier to passage of bacteria and particulate therethrough.
- 5
- 10
10. The cap according to Claim 9, wherein said sterile barrier material is hydrophobic.
- 15
11. The cap according to Claim 9, wherein said sterile barrier material is stretched, porous polytetrafluoroethylene.
12. The cap according to Claim 9, wherein said fluid passageway has an upper section, in which said plug is located, in flow communication with a diametrically enlarged section in which said inlet end is located.
- 20
13. The cap according to Claim 12, wherein said sterile barrier extends across the entire circumferential area of said diametrically enlarged section.
- 25
14. The cap according to Claim 12, wherein said plug has an upper end of larger diameter than said outlet end and further includes flow channel means for venting fluid from a vial when said plug is maintained in said upwardly extending venting position.
- 30
15. The cap according to Claim 14, wherein said flow channel means comprises a plurality of spaced apart, downwardly extending legs having their upper ends connected to said upper end of said plug and defining therebetween a path for venting fluids from a vial.
- 35
16. The cap according to Claim 15, wherein there are two downwardly depending legs.
17. The cap according to Claim 14, wherein said flow channel means comprises a plurality of radially outwardly extending fins and defining between adjacent fins flow paths for vapor being vented from a vial.
18. The cap according to Claim 14, wherein said flow channel means includes a downwardly extending section having a centrally disposed flow path and a circumferentially located venting port in communication therewith.

19. The cap according to Claim 14, wherein said flow channel means includes a downwardly extending section having a longitudinally extending surface mounted channel defining a flow path for venting vapor from a vial.
- 5 20. The cap according to Claim 12, wherein said plug has an upper end of larger diameter than said outlet end and a downwardly depending tubular section open at a lower end thereof and having an outlet port mounted in a wall of said tubular section adjacent to said larger diameter end, and said sterile barrier venting media extends across said lower end.
- 10 21. A process for freeze drying a material which comprises:
- (a) filling a vial or bottle with product under sterile conditions;
 - (b) sealing the sterilized vented cap of Claim 1 to the mouth of the bottle with the vent in the "open" position;
 - (c) freeze drying the product in the vial, allowing the water vapor to escape through the venting media and the vent port;
 - 15 (d) sealing the vent port by pressing down on the stopper.
22. The process of Claim 21 in which, after step (c), the container is filled with a dry inert gas such as nitrogen.
23. A process for freeze drying a material which comprises:
- 20 (a) filling a vial or bottle with product under sterile conditions;
 - (b) attaching a cap to a mouth of said vial or bottle, said cap having:
 - (i) a resilient stopper having a fluid passageway extending therethrough with an inlet end and an upper outlet end, said inlet end adapted to communicate with an interior of said vial or bottle, said resilient stopper having an exterior surface for sealing engagement with a mouth of said vial or bottle;
 - 25 (ii) a plug member movable within said fluid passageway, said plug member being movable between a first upwardly extending venting position and second downwardly engaging sealing position whereby in said second position fluid is precluded from flowing through said fluid passageway; and
 - 30 (iii) water vapor permeable, sterile barrier venting media located in the path of vapor travel between the interior of said vial or bottle and the exterior of said vial or bottle, and being constructed and arranged to provide a barrier to passage of bacteria and particulate there through..
 - 35
 - (c) Moving said plug into said first venting position;

- (d) freeze-drying the product in said vial or bottle with said plug in said first position, thereby allowing water vapor from said product to escape through the sterile barrier venting media; and
 - (e) moving said plug into said second sealing position by pressing down on said plug.
- 5
24. The process of Claim 23 in which, after step (d), the container is filled with a dry inert gas such as nitrogen.

FIG. 1

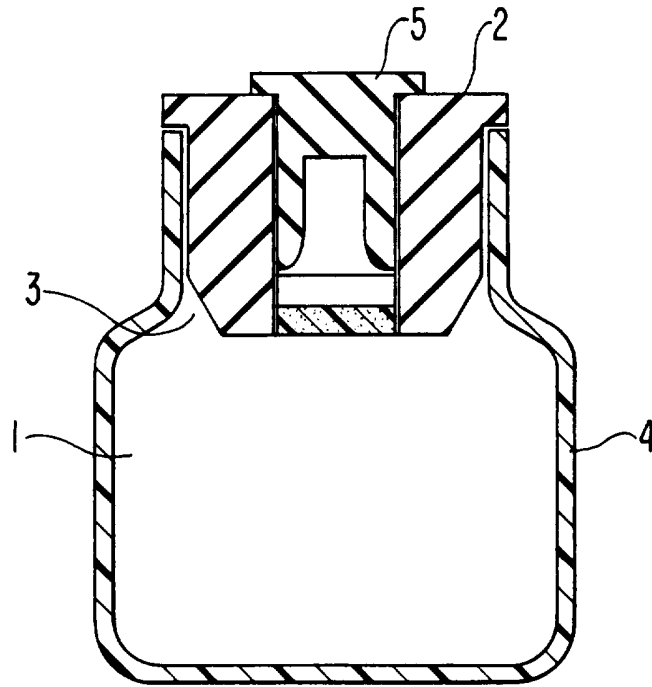
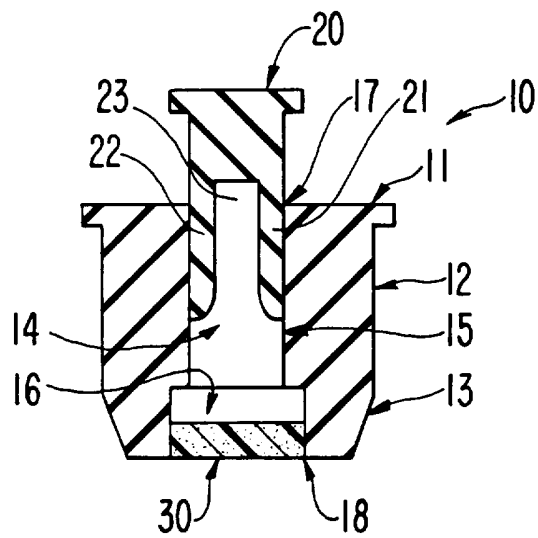

FIG. 2



2/5

FIG. 3

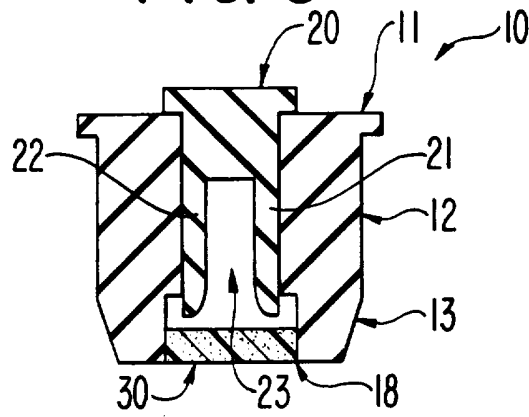

FIG. 4

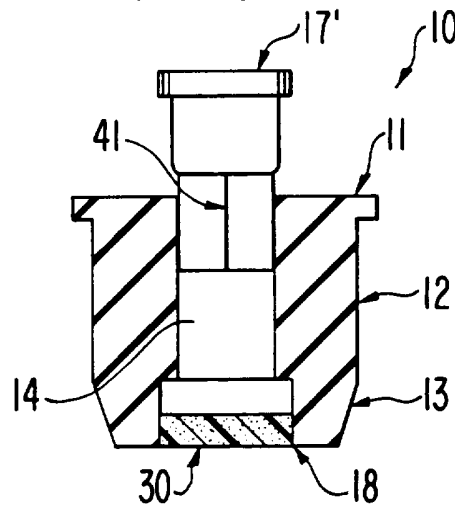

FIG. 5

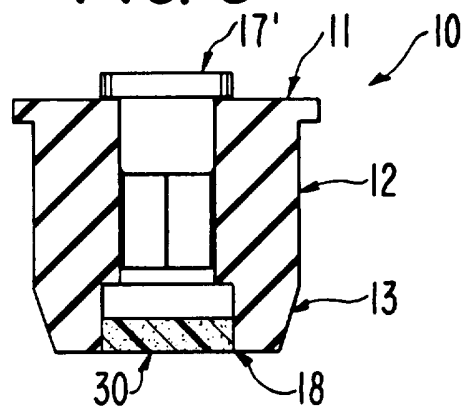

FIG. 6

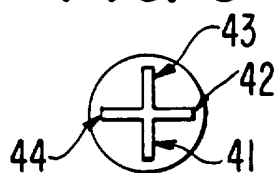

FIG. 7

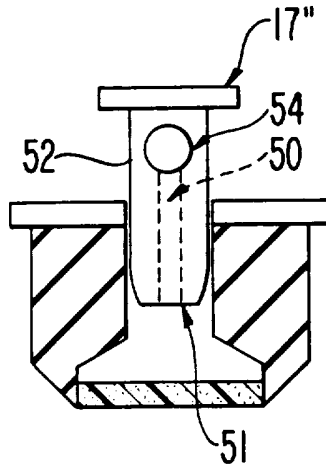

FIG. 8

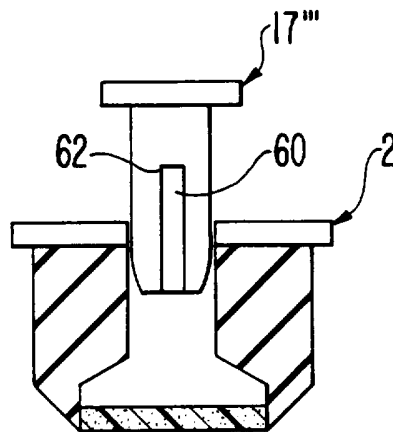

FIG. 9

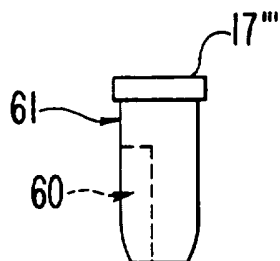

FIG. 10

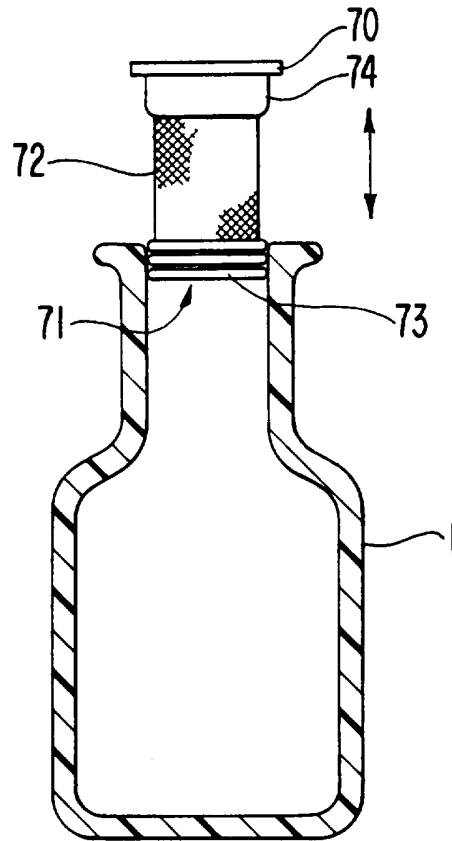

FIG. 11

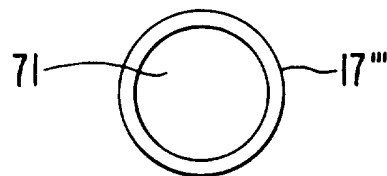

FIG. 12

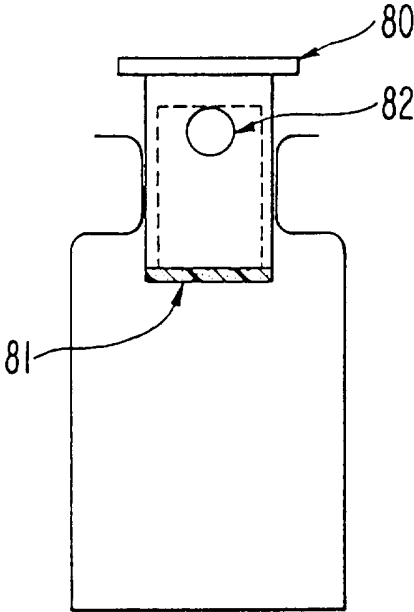
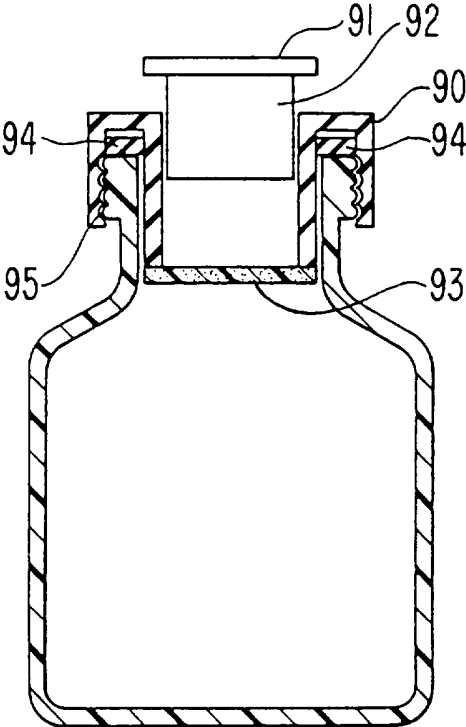

FIG. 13



INTERNATIONAL SEARCH REPORT

International Application No
PCT/US 94/11701

A. CLASSIFICATION OF SUBJECT MATTER
IPC 6 B65D51/24

According to International Patent Classification (IPC) or to both national classification and IPC

B. FIELDS SEARCHED

Minimum documentation searched (classification system followed by classification symbols)
IPC 6 B65D

Documentation searched other than minimum documentation to the extent that such documents are included in the fields searched

Electronic data base consulted during the international search (name of data base and, where practical, search terms used)

C. DOCUMENTS CONSIDERED TO BE RELEVANT

| Category * | Citation of document, with indication, where appropriate, of the relevant passages | Relevant to claim No. |
|------------|--|-----------------------|
| A | DE,A,29 00 850 (SANNER) 24 July 1980 see page 4 - page 6; claim 1; figures 1-3 --- | 1,4-6,8, 9,21,23 |
| A | EP,A,0 261 341 (SCHERING) 30 March 1988 see claims 1-8 --- | 1-3,8-11 |
| A | US,A,3 454 178 (BENDER) 8 July 1969 cited in the application see the whole document --- | 1,4-6,8, 9,21-23 |
| A | WO,A,88 01605 (GREINER) 10 March 1988 --- | |
| A | EP,A,0 500 249 (PILKINGTON) 26 August 1992 ----- | |

Further documents are listed in the continuation of box C.

Patent family members are listed in annex.

* Special categories of cited documents :

- "A" document defining the general state of the art which is not considered to be of particular relevance
- "E" earlier document but published on or after the international filing date
- "L" document which may throw doubts on priority claim(s) or which is cited to establish the publication date of another citation or other special reason (as specified)
- "O" document referring to an oral disclosure, use, exhibition or other means
- "P" document published prior to the international filing date but later than the priority date claimed

- "T" later document published after the international filing date or priority date and not in conflict with the application but cited to understand the principle or theory underlying the invention
- "X" document of particular relevance; the claimed invention cannot be considered novel or cannot be considered to involve an inventive step when the document is taken alone
- "Y" document of particular relevance; the claimed invention cannot be considered to involve an inventive step when the document is combined with one or more other such documents, such combination being obvious to a person skilled in the art.
- "&" document member of the same patent family

Date of the actual completion of the international search

19 April 1995

Date of mailing of the international search report

16.05.95

Name and mailing address of the ISA

European Patent Office, P.B. 5818 Patentlaan 2
NL - 2280 HV Rijswijk
Tel. (+ 31-70) 340-2040, Tx. 31 651 epo nl,
Fax (+ 31-70) 340-3016

Authorized officer

Bessy, M

INTERNATIONAL SEARCH REPORT

Information on patent family members

| |
|--|
| International Application No PCT/US 94/11701 |
|--|

| Patent document cited in search report | Publication date | Patent family member(s) | Publication date |
|--|------------------|-------------------------|------------------|
| DE-A-2900850 | 24-07-80 | NONE | |
| | | | |
| EP-A-261341 | 30-03-88 | DE-A- 3627990 | 25-02-88 |
| | | US-A- 4863051 | 05-09-89 |
| | | | |
| US-A-3454178 | 08-07-69 | NONE | |
| | | | |
| WO-A-8801605 | 10-03-88 | DE-A- 3628930 | 05-05-88 |
| | | FR-A, B 2603258 | 04-03-88 |
| | | GB-A- 2214498 | 06-09-89 |
| | | JP-T- 1503595 | 07-12-89 |
| | | | |
| EP-A-500249 | 26-08-92 | US-A- 5238153 | 24-08-93 |
| | | AU-B- 654692 | 17-11-94 |
| | | AU-A- 1084492 | 27-08-92 |
| | | CA-A- 2061412 | 20-08-92 |
| | | CN-A- 1065838 | 04-11-92 |
| | | JP-A- 4312462 | 04-11-92 |
| | | | |