

(19) World Intellectual Property Organization  
International Bureau



(43) International Publication Date  
17 April 2008 (17.04.2008)

PCT

(10) International Publication Number  
**WO 2008/043122 A1**

(51) International Patent Classification:  
*B81B 7/02* (2006.01) *B41J 2/05* (2006.01)

(74) Agent: SILVERBROOK RESEARCH PTY LTD; 393 Darling Street, Balmain, New South Wales 2041 (AU).

(21) International Application Number:  
PCT/AU2006/001477

(81) Designated States (unless otherwise indicated, for every kind of national protection available): AE, AG, AL, AM, AT, AU, AZ, BA, BB, BG, BR, BW, BY, BZ, CA, CH, CN, CO, CR, CU, CZ, DE, DK, DM, DZ, EC, EE, EG, ES, FI, GB, GD, GE, GH, GM, HN, HR, HU, ID, IL, IN, IS, JP, KE, KG, KM, KN, KP, KR, KZ, LA, LC, LK, LR, LS, LT, LU, LV, LY, MA, MD, MG, MK, MN, MW, MX, MY, MZ, NA, NG, NI, NO, NZ, OM, PG, PH, PL, PT, RO, RS, RU, SC, SD, SE, SG, SK, SL, SM, SV, SY, TJ, TM, TN, TR, TT, TZ, UA, UG, US, UZ, VC, VN, ZA, ZM, ZW.

(22) International Filing Date: 9 October 2006 (09.10.2006)

(25) Filing Language: English

(26) Publication Language: English

(71) Applicant (for all designated States except US): SILVERBROOK RESEARCH PTY LTD [AU/AU]; 393 Darling Street, Balmain, New South Wales 2041 (AU).

(84) Designated States (unless otherwise indicated, for every kind of regional protection available): ARIPO (BW, GH, GM, KE, LS, MW, MZ, NA, SD, SL, SZ, TZ, UG, ZM, ZW), Eurasian (AM, AZ, BY, KG, KZ, MD, RU, TJ, TM), European (AT, BE, BG, CH, CY, CZ, DE, DK, EE, ES, FI, FR, GB, GR, HU, IE, IS, IT, LT, LU, LV, MC, NL, PL, PT, RO, SE, SI, SK, TR), OAPI (BF, BJ, CF, CG, CI, CM, GA, GN, GQ, GW, ML, MR, NE, SN, TD, TG).

(72) Inventors; and

(75) Inventors/Applicants (for US only): NORTH, Angus, John [AU/AU]; 393 Darling Street, Balmain, New South Wales 2041 (AU). MYERS, Samuel, James [AU/AU]; 393 Darling Street, Balmain, New South Wales 2041 (AU). SILVERBROOK, Kia [AU/AU]; 393 Darling Street, Balmain, New South Wales 2041 (AU).

Published:  
— with international search report

(54) Title: MEMS BUBBLE GENERATOR FOR LARGE STABLE VAPOR BUBBLES

Shaped input pulse (amplitude modulation)

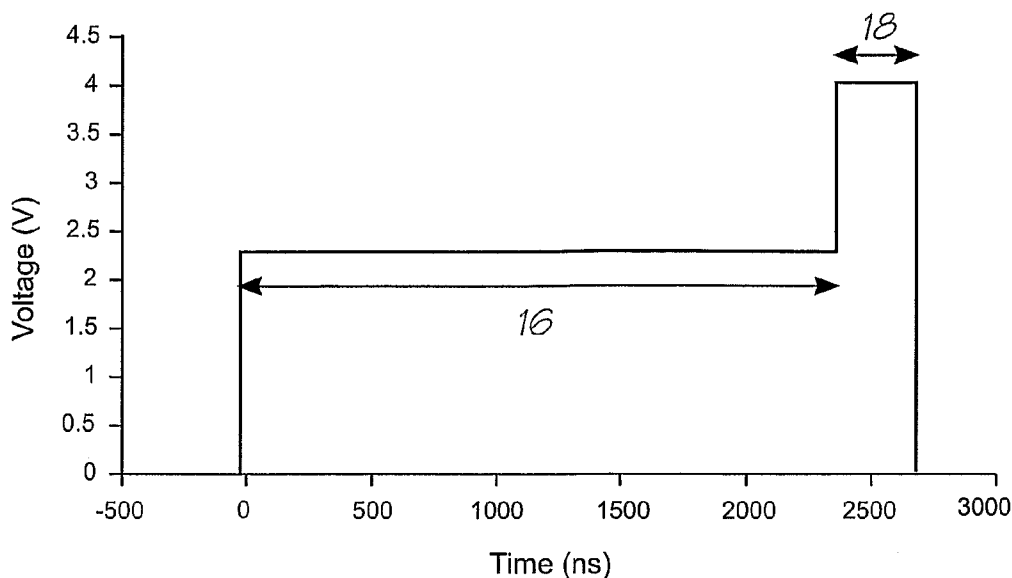

(57) Abstract: A MEMS vapour bubble generator that uses a heater in thermal contact with a liquid to generate a bubble. The heater is energized by an electrical pulse that is shaped to have a relatively low power, sub-nucleating portion and a high power portion that nucleates the bubble. The thermal energy transferred to the liquid by the sub-nucleating portion speeds up the nucleation of the bubble across the surface of the heater during the nucleating portion. This produces larger, more stable bubble having a regular shape.

WO 2008/043122 A1

**MEMS BUBBLE GENERATOR FOR LARGE STABLE VAPOR BUBBLES****Field of the Invention**

- 5           The invention relates to MEMS devices and in particular MEMS devices that vaporize liquid to generate a vapor bubble during operation.

**Cross References to Related Applications**

Various methods, systems and apparatus relating to the present invention are disclosed in the following US

- 10 Patents/ Patent Applications filed by the applicant or assignee of the present invention:

09/575197	7079712	09/575123	6825945	09/575165	6813039	6987506
7038797	6980318	6816274	7102772	09/575186	6681045	6728000
09/575145	7088459	09/575181	7068382	7062651	6789194	6789191
6644642	6502614	6622999	6669385	6549935	6987573	6727996
6591884	6439706	6760119	09/575198	6290349	6428155	6785016
6870966	6822639	6737591	7055739	09/575129	6830196	6832717
6957768	09/575162	09/575172	09/575170	7106888	09/575161	09/517539
6566858	6331946	6246970	6442525	09/517384	09/505951	6374354
09/517608	6816968	6757832	6334190	6745331	09/517541	10/203559
10/203560	7093139	10/636263	10/636283	10/866608	10/902889	10/902833
10/940653	10/942858	10/727181	10/727162	10/727163	10/727245	10/727204
10/727233	10/727280	10/727157	10/727178	7096137	10/727257	10/727238
10/727251	10/727159	10/727180	10/727179	10/727192	10/727274	10/727164
10/727161	10/727198	10/727158	10/754536	10/754938	10/727227	10/727160
10/934720	11/212702	11/272491	11/474278	11/488853	11/488841	10/296522
6795215	7070098	09/575109	6805419	6859289	6977751	6398332
6394573	6622923	6747760	6921144	10/884881	7092112	10/949294
11/039866	11/123011	6986560	7008033	11/148237	11/248435	11/248426
11/478599	11/499749	10/922846	10/922845	10/854521	10/854522	10/854488
10/854487	10/854503	10/854504	10/854509	10/854510	7093989	10/854497
10/854495	10/854498	10/854511	10/854512	10/854525	10/854526	10/854516
10/854508	10/854507	10/854515	10/854506	10/854505	10/854493	10/854494
10/854489	10/854490	10/854492	10/854491	10/854528	10/854523	10/854527
10/854524	10/854520	10/854514	10/854519	10/854513	10/854499	10/854501
10/854500	10/854502	10/854518	10/854517	10/934628	11/212823	11/499803
10/728804	10/728952	7108355	6991322	10/728790	10/728884	10/728970
10/728784	10/728783	7077493	6962402	10/728803	10/728780	10/728779
10/773189	10/773204	10/773198	10/773199	6830318	10/773201	10/773191
10/773183	7108356	10/773196	10/773186	10/773200	10/773185	10/773192

10/773197	10/773203	10/773187	10/773202	10/773188	10/773194	7111926
10/773184	7018021	11/060751	11/060805	11/188017	11/298773	11/298774
11/329157	11/490041	11/501767	11/499736	11/505935	11/506172	11/505846
11/505857	11/505856	MTB54US	6623101	6406129	6505916	6457809
6550895	6457812	10/296434	6428133	10/407212	10/407207	10/683064
10/683041	6750901	6476863	6788336	11/097308	11/097309	11/097335
11/097299	11/097310	11/097213	11/210687	11/097212	11/212637	10/760272
10/760273	7083271	10/760182	7080894	10/760218	7090336	10/760216
10/760233	10/760246	7083257	10/760243	10/760201	10/760185	10/760253
10/760255	10/760209	10/760208	10/760194	10/760238	7077505	10/760235
7077504	10/760189	10/760262	10/760232	10/760231	10/760200	10/760190
10/760191	10/760227	7108353	7104629	11/446227	11/454904	11/472345
11/474273	11/478594	11/474279	11/482939	11/482950	11/499709	10/815625
10/815624	10/815628	10/913375	10/913373	10/913374	10/913372	10/913377
10/913378	10/913380	10/913379	10/913376	10/913381	10/986402	11/172816
11/172815	11/172814	11/482990	11/482986	11/482985	11/454899	11/003786
11/003616	11/003418	11/003334	11/003600	11/003404	11/003419	11/003700
11/003601	11/003618	11/003615	11/003337	11/003698	11/003420	6984017
11/003699	11/071473	11/003463	11/003701	11/003683	11/003614	11/003702
11/003684	11/003619	11/003617	11/293800	11/293802	11/293801	11/293808
11/293809	11/482975	11/482970	11/482968	11/482972	11/482971	11/482969
11/246676	11/246677	11/246678	11/246679	11/246680	11/246681	11/246714
11/246713	11/246689	11/246671	11/246670	11/246669	11/246704	11/246710
11/246688	11/246716	11/246715	11/293832	11/293838	11/293825	11/293841
11/293799	11/293796	11/293797	11/293798	11/293804	11/293840	11/293803
11/293833	11/293834	11/293835	11/293836	11/293837	11/293792	11/293794
11/293839	11/293826	11/293829	11/293830	11/293827	11/293828	11/293795
11/293823	11/293824	11/293831	11/293815	11/293819	11/293818	11/293817
11/293816	10/760254	10/760210	10/760202	10/760197	10/760198	10/760249
10/760263	10/760196	10/760247	10/760223	10/760264	10/760244	7097291
10/760222	10/760248	7083273	10/760192	10/760203	10/760204	10/760205
10/760206	10/760267	10/760270	10/760259	10/760271	10/760275	10/760274
10/760268	10/760184	10/760195	10/760186	10/760261	7083272	11/501771
11/014764	11/014763	11/014748	11/014747	11/014761	11/014760	11/014757
11/014714	11/014713	11/014762	11/014724	11/014723	11/014756	11/014736
11/014759	11/014758	11/014725	11/014739	11/014738	11/014737	11/014726
11/014745	11/014712	11/014715	11/014751	11/014735	11/014734	11/014719
11/014750	11/014749	11/014746	11/014769	11/014729	11/014743	11/014733
11/014754	11/014755	11/014765	11/014766	11/014740	11/014720	11/014753
11/014752	11/014744	11/014741	11/014768	11/014767	11/014718	11/014717

11/014716	11/014732	11/014742	11/097268	11/097185	11/097184	11/293820
11/293813	11/293822	11/293812	11/293821	11/293814	11/293793	11/293842
11/293811	11/293807	11/293806	11/293805	11/293810	11/246707	11/246706
11/246705	11/246708	11/246693	11/246692	11/246696	11/246695	11/246694
11/482958	11/482955	11/482962	11/482963	11/482956	11/482954	11/482974
11/482957	11/482987	11/482959	11/482960	11/482961	11/482964	11/482965
11/482976	11/482973	11/495815	11/495816	11/495817	11/124158	11/124196
11/124199	11/124162	11/124202	11/124197	11/124154	11/124198	11/124153
11/124151	11/124160	11/124192	11/124175	11/124163	11/124149	11/124152
11/124173	11/124155	11/124157	11/124174	11/124194	11/124164	11/124200
11/124195	11/124166	11/124150	11/124172	11/124165	11/124186	11/124185
11/124184	11/124182	11/124201	11/124171	11/124181	11/124161	11/124156
11/124191	11/124159	11/124175	11/124188	11/124170	11/124187	11/124189
11/124190	11/124180	11/124193	11/124183	11/124178	11/124177	11/124148
11/124168	11/124167	11/124179	11/124169	11/187976	11/188011	11/188014
11/482979	11/228540	11/228500	11/228501	11/228530	11/228490	11/228531
11/228504	11/228533	11/228502	11/228507	11/228482	11/228505	11/228497
11/228487	11/228529	11/228484	11/228489	11/228518	11/228536	11/228496
11/228488	11/228506	11/228516	11/228526	11/228539	11/228538	11/228524
11/228523	11/228519	11/228528	11/228527	11/228525	11/228520	11/228498
11/228511	11/228522	11/228515	11/228537	11/228534	11/228491	11/228499
11/228509	11/228492	11/228493	11/228510	11/228508	11/228512	11/228514
11/228494	11/228495	11/228486	11/228481	11/228477	11/228485	11/228483
11/228521	11/228517	11/228532	11/228513	11/228503	11/228480	11/228535
11/228478	11/228479	11/246687	11/246718	11/246685	11/246686	11/246703
11/246691	11/246711	11/246690	11/246712	11/246717	11/246709	11/246700
11/246701	11/246702	11/246668	11/246697	11/246698	11/246699	11/246675
11/246674	11/246667	11/246684	11/246672	11/246673	11/246683	11/246682
11/482953	11/482977	6238115	6386535	6398344	6612240	6752549
6805049	6971313	6899480	6860664	6925935	6966636	7024995
10/636245	6926455	7056038	6869172	7021843	6988845	6964533
6981809	11/060804	11/065146	11/155544	11/203241	11/206805	11/281421
11/281422	11/482981	11/014721	29/219503	11/482978	11/482967	11/482966
11/482988	11/482989	11/482982	11/482983	11/482984	11/495818	11/495819

An application has been listed by its docket number. This will be replaced when application number is known. The disclosures of these applications and patents are incorporated herein by reference.

## 5 Background of the Invention

Some micro-mechanical systems (MEMS) devices process or use liquids to operate. In one class of these liquid-containing devices, resistive heaters are used to heat the liquid to the liquid's superheat limit,

resulting in the formation of a rapidly expanding vapor bubble. The impulse provided by the bubble expansion can be used as a mechanism for moving liquid through the device. This is the case in thermal inkjet printheads where each nozzle has a heater that generates a bubble to eject a drop of ink onto the print media. In light of the widespread use of inkjet printers, the present invention will be described with particular reference to its use in this application. However, it will be appreciated that the invention is not limited to inkjet printheads and is equally suited to other devices in which vapor bubbles formed by resistive heaters are used to move liquid through the device (e.g. some 'Lab-on-a-chip' devices).

The time scale for heating a liquid to its superheat limit determines how much thermal energy will be stored in the liquid when the superheat limit is reached: this determines how much vapor will be produced and the impulse of the expanding vapor bubble (impulse being defined as pressure integrated over area and time). Longer time scales for heating result in a greater volume of liquid being heated and hence a larger amount of stored energy, a larger amount of vapor and larger bubble impulse. This leads to some degree of tunability for the bubbles produced by MEMS heaters. Controlling the time scale for heating to the superheat limit is simply a matter of controlling the power supplied to the heater during the nucleation event: lower power will result in a longer nucleation time and larger bubble impulse, at the cost of an increased energy requirement (the extra energy stored in the liquid must be supplied by the heater). Controlling the power may be done by way of reduced voltage across the heater or by way of pulse width modulation of the voltage to obtain a lower time averaged power.

While this effect may be useful in controlling e.g. the flow rate of a MEMS bubble pump or the force applied to a clogged nozzle in an inkjet printer (the subject of a co-pending application referred to temporarily by Docket Number PUA011US), the designer of such a system must be wary of ensuring bubble stability. A typical heater heating a water-based liquid will generate unstable, non-repeatable bubbles if the time scale for heating is much longer than 1 microsecond (see Figure 1). This non-repeatability will compromise device operation or severely limit the range of bubble impulse available to the designer.

### Summary of the Invention

Accordingly the present invention provides a MEMS vapour bubble generator comprising:

- a chamber for holding liquid;
- a heater positioned in the chamber for thermal contact with the liquid; and,
- drive circuitry for providing the heater with an electrical pulse such that the heater generates a vapour bubble in the liquid; wherein,

the pulse has a first portion with insufficient power to nucleate the vapour bubble and a second portion with power sufficient to nucleate the vapour bubble, subsequent to the first portion.

If the heating pulse is shaped to increase the heating rate prior to the end of the pulse, bubble stability can be greatly enhanced, allowing access to a regime where large, repeatable bubbles can be produced by small heaters.

Preferably the first portion of the pulse is a pre-heat section for heating the liquid but not nucleating the vapour bubble and the second portion is a trigger section for nucleating the vapour bubble. In a further preferred form, the pre-heat section has a longer duration than the trigger section. Preferably, the pre-heat section is at least two micro-seconds long. In a further preferred form, the trigger section is less than a  
5 micro-section long.

Preferably, the drive circuitry shapes the pulse using pulse width modulation. In this embodiment, the pre-heat section is a series of sub-nucleating pulses. Optionally, the drive circuitry shapes the pulse using  
10 voltage modulation.

In some embodiments, the time averaged power in the pre-heat section is constant and the time averaged power in the trigger section is constant. In particularly preferred embodiments, the MEMS vapour bubble generator is used in an inkjet printhead to eject printing fluid from nozzle in fluid communication with the chamber.  
15

Using a low power over a long time scale (typically  $\gg 1\mu\text{s}$ ) to store a large amount of thermal energy in the liquid surrounding the heater without crossing over the nucleation temperature, then switching to a high power to cross over the nucleation temperature in a short time scale (typically  $< 1\mu\text{s}$ ), triggers nucleation and releasing the stored energy.  
20

Optionally, the first portion of the pulse is a pre-heat section for heating the liquid but not nucleating the vapour bubble and the second portion is a trigger section for superheating some of the liquid to nucleate the vapour bubble.

25 Optionally, the pre-heat section has a longer duration than the trigger section.

Optionally, the pre-heat section is at least two micro-seconds long.

Optionally, the trigger section is less than one micro-section long.  
30

Optionally, the drive circuitry shapes the pulse using pulse width modulation.

Optionally, the pre-heat section is a series of sub-nucleating pulses.

35 Optionally, the drive circuitry shapes the pulse using voltage modulation.

Optionally, the time averaged power in the pre-heat section is constant and the time averaged power in the trigger section is constant.

40 In another aspect the present invention provides a MEMS vapour bubble generator used in an inkjet printhead to eject printing fluid from a nozzle in fluid communication with the chamber.

Optionally, the heater is suspended in the chamber for immersion in a printing fluid.

Optionally, the pulse is generated for recovering a nozzle clogged with dried or overly viscous printing fluid.

5

#### **Brief Description of Drawings**

Preferred embodiments of the invention will now be described with reference to the accompanying drawings, in which:

Figures 1A to 1E show water vapour bubbles generated at different heating rates;

10 Figure 2A and 2B show two alternatives for shaping the pulse into pre-heat and trigger sections;

Figure 3 is a plot of the hottest point on a heater and a cooler point on the heater for two different pulse shapes;

Figure 4A shows water vapour bubbles generated using a traditional square-shaped pulse;

Figure 4B shows a bubble generated using a pulse shaped by pulse width modulation;

15 Figures 4C and 4D show a bubble generated using voltage modulated pulses; and,

Figure 5 shows the MEMS bubble generator in use within an inkjet printhead.

#### **Detailed Description of the Preferred Embodiments**

20 In a MEMS fluid pump, large, stable and repeatable bubbles are desirable for efficient and reliable operation. To analyse the mechanisms that influence bubble nucleation and growth, it is necessary to consider the spatial uniformity of the heater's temperature profile and then consider the time evolution of the profile. Finite element thermal models of heaters in liquid can be used to show that the heating rate of the heater strongly influences the spatial uniformity of temperature across the heater. This is because since  
25 different portions of the heater are heat-sunk to different degrees (the sides of the heater will be colder due to enhanced cooling by the liquid and the ends of the heater will be colder due to enhanced cooling by the contacts). At low powers, where the time scale for heating to the superheat limit is large with respect to the thermal time scales of the cooling mechanisms, the temperature profile of the heater will be strongly distorted by cooling at the boundaries of the heater. Ideally the temperature profile would be a "top-hat", with uniform  
30 temperature across the whole heater, but in the case of low heating rates, the edges of the temperature profile will be pulled down.

The top-hat temperature profile is ideal for maximising the effectiveness of the heater, as only those portions of the heater above the superheat limit will contribute significantly to the bubble impulse. The  
35 nucleation rate is a very strong exponential function of temperature near the superheat limit. Portions of the heater that are even a few degrees below the superheat limit will produce a much lower nucleation rate than those portions above the superheat limit. These portions of the heater have much less contribution to the bubble impulse as they will be thermally isolated by bubbles expanding from hotter portions of the heater. In other words, if the temperature profile across the heater is not uniform, there can exist a race condition  
40 between bubble nucleation on colder parts of the heater and bubbles expanding from hotter parts of the heater. It is this race condition that can cause the non-repeatability of bubbles formed with low heating rates.

The term "low heating rates" is a relative term and depends on the geometry of the heater and its contacts and the thermal properties of all materials in thermal contact with the heater. All of these will influence the time scales of the cooling mechanisms. A typical heater material in a typical configuration applicable to inkjet printers will begin to manifest the race condition if the time scale for nucleation exceeds 1  $\mu$ s. The exact threshold is unimportant as any heater will be subject to the race condition and the consequent bubble instability if the heating rate is low enough. This will limit the range of bubble impulse available to the designer.

Figures 1A to 1E are line drawings of stroboscopic photographs of vapour bubbles 12 generated at different heating rates by varying the voltage of the drive pulse. Using a strobe with a duration of 0.3 microseconds, the images show capture the bubbles at their greatest extent. The heater 10 is 30  $\mu$ m x 4  $\mu$ m in an open pool of water at an angle of 15 degrees from the support wafer surface. The dual bubble appearance is due to a reflected image of the bubble on the wafer surface.

In Figure 1A, the drive voltage is 5 volts and the bubble 12 reaches its maximum extent at 1 microsecond. The bubble is relatively small but has a regular shape along the heater length. In Figure 1B, the drive voltage decreases to 4.1 volts and the time to maximum bubble growth increases to 2 microseconds. Consequently, the bubble 12 is larger but bubble irregularities 14 start to occur. The pulse voltage progressively decreases in Figures 1C, 1D and 1E (3.75V, 3.45V and 2.95V respectively). As the voltage decreases, so to does the heating rate, thereby increasing the time scale for reaching the liquid superheat limit. This allows more time for heat leakage into the liquid, resulting in a larger amount of stored thermal energy and the production of more vapor when bubble nucleation occurs. In other words, the size of the bubble 12 increases. Lower voltages therefore result in greater bubble impulse, allowing the bubble to grow to a greater extent. Unfortunately, the irregularities 12 in the bubble shape also increase. Hence the bubble is potentially unstable and non-repeatable when the time scale for heating to the superheat limit exceeds 1 microsecond. In Figures 1A to 1 E, the time to maximum bubble size is 1, 2, 3, 5, and 10 microseconds respectively.

The invention provides a way of avoiding the instability caused by the race condition so that the designer can use low heating rates to generate a large bubble impulse on a heater with fixed geometry and thermal properties. Figures 2A and 2B shows two possibilities for driving the heaters to produce large, stable bubbles. In Figure 2A, the drive circuit uses amplitude modulation to decrease the power of the pre-heat section 16 relative to the trigger section 18. In Figure 2B, pulse width modulation of the voltage (creating a rapid series of sub-ejection pulses) can be used to reduce the power of the pre-heat phase 16 compared to the trigger section 18.

Ordinary workers in this field will appreciate that there are an infinite variety of pulse shapes that will satisfy the criteria of a relatively low powered pre-heat section and a subsequent trigger section that nucleates the bubble. Shaping the pulse can be done with pulse width modulation, voltage modulation or a combination of both. However, pulse width modulation is the preferred method of shaping the pulse, being

more amenable to CMOS circuit design. It should also be noted that the pulse is not limited to a pre-heat and trigger section only; additional pulse sections may be included for other purposes without negating the benefits of the present invention. Furthermore, the sections need not maintain constant power levels. Constant time averaged power is preferred for the pre-heat section and the trigger section, as that is the simplest case to handle theoretically and experimentally.

By switching to a higher heating rate after a pre-heat phase the race is won by bubble nucleation because the time lag between different regions of the heater reaching the superheat limit is reduced. Figure 3 illustrates the concept: even if the spatial temperature uniformity is poor (an unavoidable side effect of low heating rates in the pre-heat phase), the time lag between the hotter and colder regions of the heater reaching the superheat limit can be reduced by switching to a higher heating rate after the pre-heat. In this way, the colder regions reach the superheat limit before they are thermally isolated by bubbles expanding from hotter regions. The majority of the heater surface reaches the superheat limit before significant bubble expansion occurs, so the heater area will be more effectively and consistently utilised for bubble formation.

Figures 4A to 4D demonstrate the effectiveness of shaped pulses in producing large, stable bubbles. The bubble size can be increased tremendously using shaped pulses, without suffering the irregularity shown in Figures 1A to 1E. A circuit designer will have a choice of voltage modulation or pulse width modulation of the heating signal to create the shaped pulse, but generally pulse width modulation is considered more suitable to integration with e.g. a CMOS driver circuit. As an example, such a circuit may be used to generate maintenance pulses in an inkjet printhead, where the increased bubble impulse is better able to recover clogged nozzles as part of a printer maintenance cycle. This is discussed in the co-pending application (temporarily referred to by docket number PUA011US), the contents of which are incorporated herein by reference.

Figure 5 shows the MEMS bubble generator of the present invention applied to an inkjet printhead. A detailed description of the fabrication and operation of some of the Applicant's thermal printhead IC's is provided in USSN 11/097,308 and USSN 11/246,687. In the interests of brevity, the contents of these documents are incorporated herein by reference.

A single nozzle device 30 is shown in Figure 5. It will be appreciated that an array of such nozzles are formed on a supporting wafer substrate 28 using lithographic etching and deposition techniques common within in the field semi-conductor/MEMS fabrication. The chamber 20 holds a quantity of ink. The heater 10 is suspended in the chamber 20 such that it is in electrical contact with the CMOS drive circuitry 22. Drive pulses generated by the drive circuitry 22 heat the heater 10 to generate a vapour bubble 12 that forces a droplet of ink 24 through the nozzle 26. Using the drive circuitry 22 to shape the pulse in accordance with the present invention gives the designer a broader range of bubble impulses from a single heater and drive voltage.

Figures 4A to 4D show stroboscopic images of water vapor bubbles in an open pool on a  $30\mu\text{m} \times 4\mu\text{m}$  heater. Like Figures 1A to 1E, the bubbles 12 have been captured at their maximum extent. Figure 4A shows the prior art situation of a simple square profile pulse of 4.2V for 0.7 microseconds. In Figure 4B, the pulse is shaped by pulse width modulation - a pre-heat series having nine 100 nano-second pulses separated by 150 nano-seconds, followed by a trigger pulse of 300 nano-seconds, all at 4.2V. The bubble size in Figure 4B is greater because of the amount of thermal energy transferred to the liquid prior to nucleation in the trigger pulse. In Figures 4C and 4D, the pulses are voltage modulated. The pulse of Figure 4C has a pre-heat portion of 2.4V for 8 microseconds, followed by 4V for 0.1 microseconds to trigger nucleation. In contrast, the Figure 4D pulse has a pre-heat section of 2.25V for 16 microseconds followed by a trigger of 4.2V for 0.15 microseconds. These figures clearly illustrate that bubbles generated using shaped pulses (Figures 4B, 4C and 4D) are larger, regular in shape and repeatable.

With the problem of irregularity or non-repeatability removed, the designer has great flexibility in controlling the bubble size at the design phase or during operation by altering the length of the pre-heat section of the pulse. Care must be given to avoiding accidentally exceeding the superheat limit during the pre-heat section so that nucleation does not occur until the trigger section. If the pulse is pulse width modulated, the modulation should be fast enough to give a reasonable approximation of the temperature rise generated by a constant, reduced voltage. Care must also be given to ensuring the trigger section takes the whole heater above the superheat limit with enough margin to account for system variances, without overdriving to the extent that the heater is damaged. These considerations can be met with routine thermal modelling or experiment with the heater in an open pool of liquid.

The invention has been described herein by way of example only. Ordinary workers in this field will readily recognise many variations and modifications that do not depart from the spirit and scope of the broad inventive concept.

## CLAIMS

1. A MEMS vapour bubble generator comprising:  
a chamber for holding liquid;  
a heater positioned in the chamber for thermal contact with the liquid; and,  
5 drive circuitry for providing the heater with an electrical pulse such that the heater generates a vapour bubble in the liquid; wherein,  
the pulse has a first portion with insufficient power to nucleate the vapour bubble and a second portion with power sufficient to nucleate the vapour bubble, subsequent to the first portion.
- 10 2. A MEMS vapour bubble generator according to claim 1 wherein the first portion of the pulse is a pre-heat section for heating the liquid but not nucleating the vapour bubble and the second portion is a trigger section for superheating some of the liquid to nucleate the vapour bubble.
3. A MEMS vapour bubble generator according to claim 2 wherein the pre-heat section has a longer  
15 duration than the trigger section.
4. A MEMS vapour bubble generator according to claim 3 wherein the pre-heat section is at least two micro-seconds long.
- 20 5. A MEMS vapour bubble generator according to claim 3 wherein the trigger section is less than one micro-section long.
6. A MEMS vapour bubble generator according to claim 1 wherein the drive circuitry shapes the pulse using pulse width modulation.
- 25 7. A MEMS vapour bubble generator according to claim 6 wherein the pre-heat section is a series of sub-nucleating pulses.
8. A MEMS vapour bubble generator according to claim 1 wherein the drive circuitry shapes the pulse  
30 using voltage modulation.
9. A MEMS vapour bubble generator according to claim 2 wherein the time averaged power in the pre-heat section is constant and the time averaged power in the trigger section is constant.
- 35 10. A MEMS vapour bubble generator according to claim 1 used in an inkjet printhead to eject printing fluid from a nozzle in fluid communication with the chamber.
11. A MEMS vapour bubble generator according to claim 10 wherein the heater is suspended in the  
40 chamber for immersion in a printing fluid.

12. A MEMS vapour bubble generator according to claim 10 wherein the pulse is generated for recovering a nozzle clogged with dried or overly viscous printing fluid.

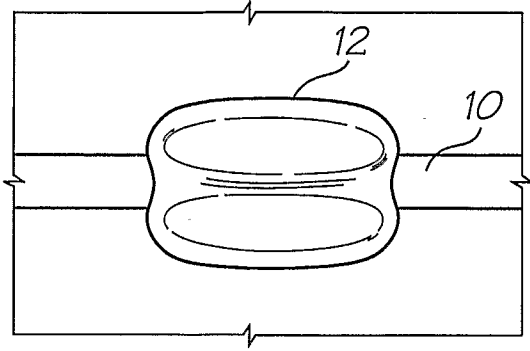

FIG. 1A

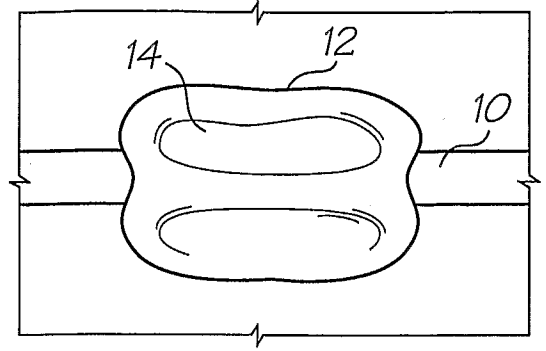

FIG. 1B

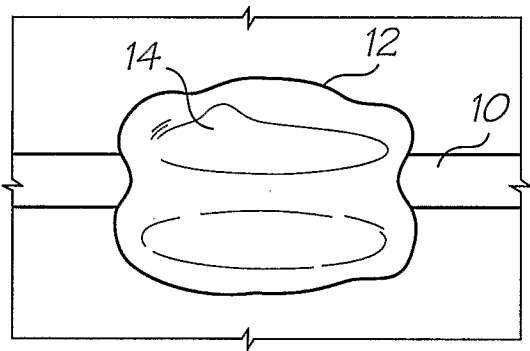

FIG. 1C

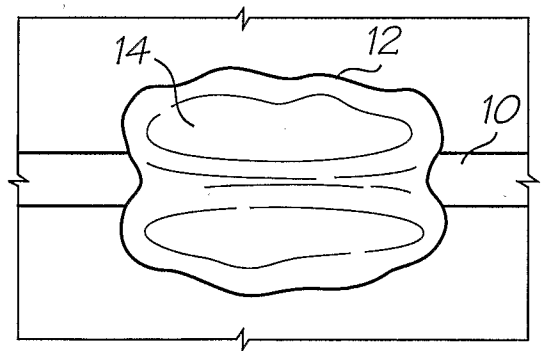

FIG. 1D

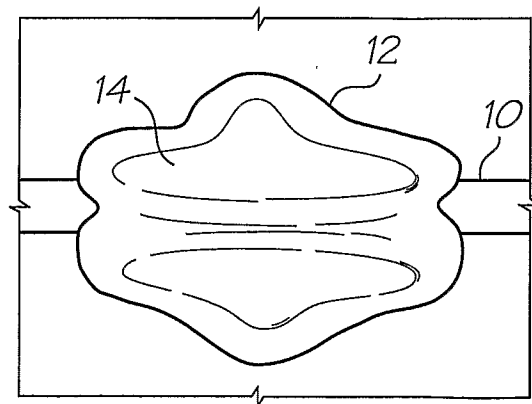

FIG. 1E

Shaped input pulse (amplitude modulation)

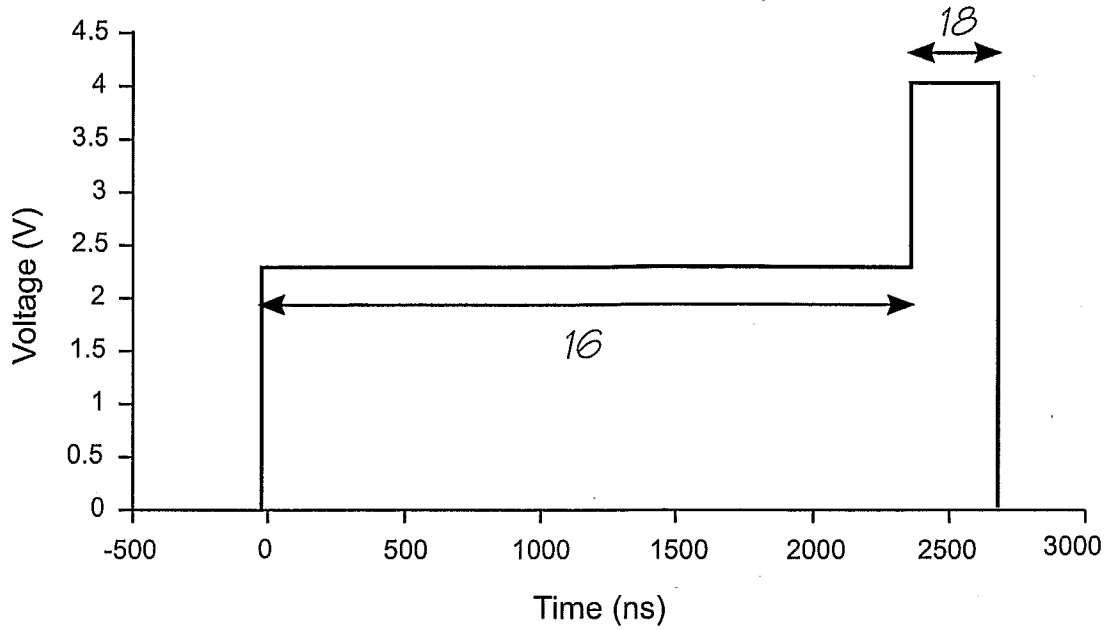

FIG. 2A

Shaped input pulse (pulse width modulation)

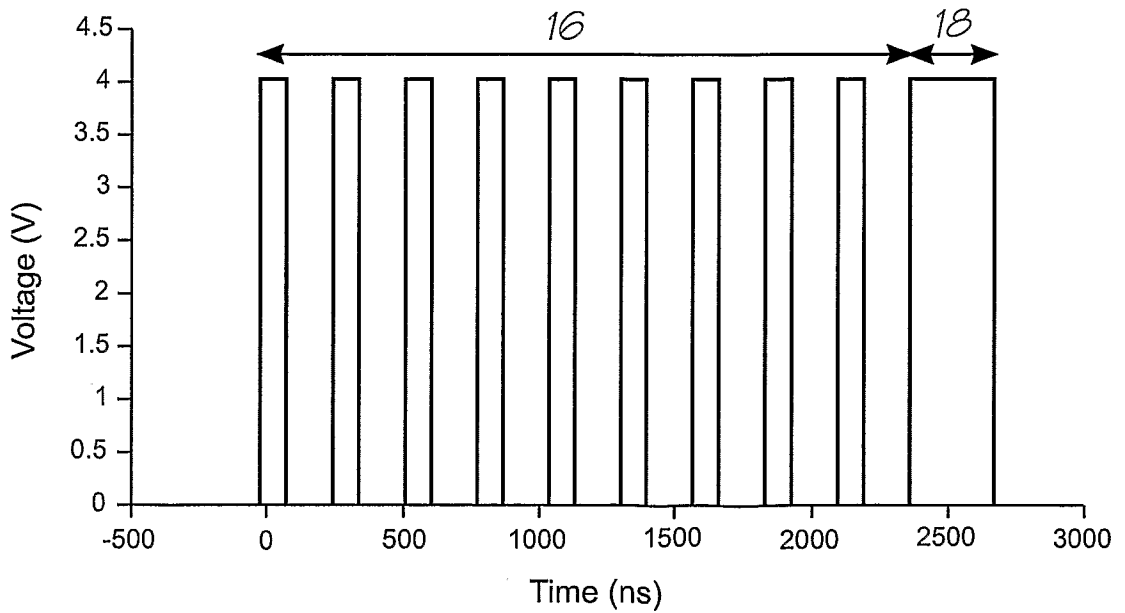

FIG. 2B

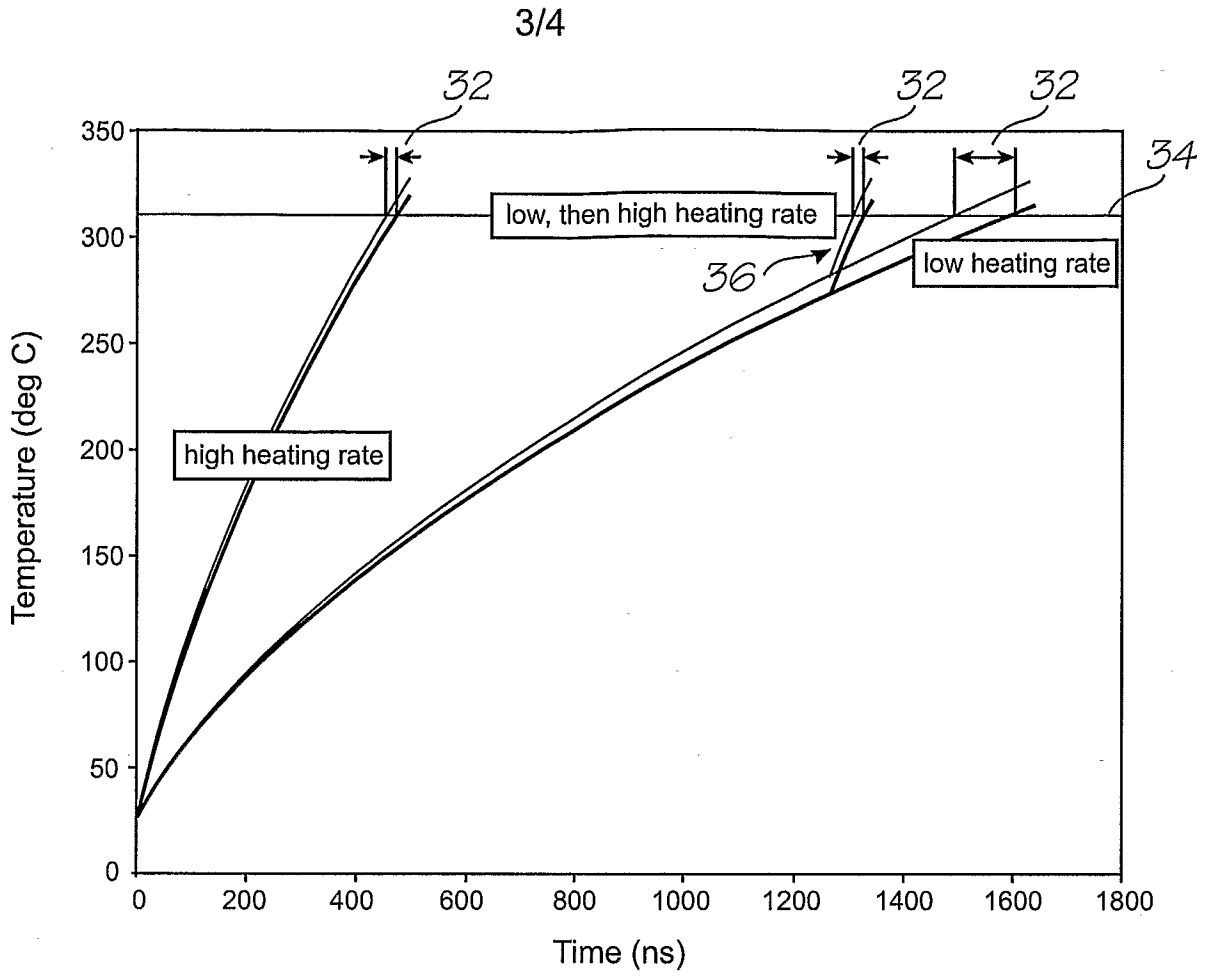

FIG. 3

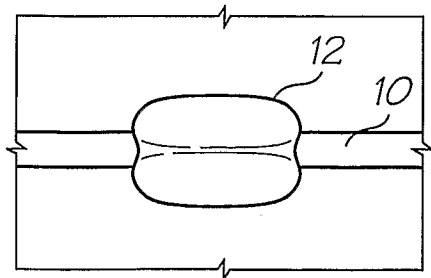

FIG. 4A

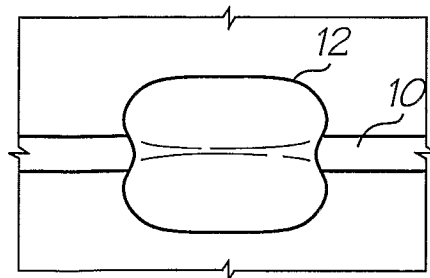

FIG. 4B

4/4

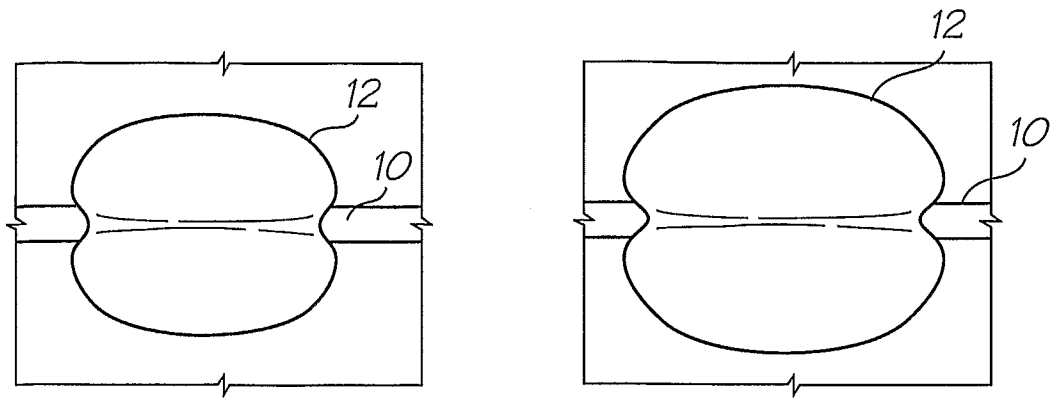

FIG. 4C

FIG. 4D

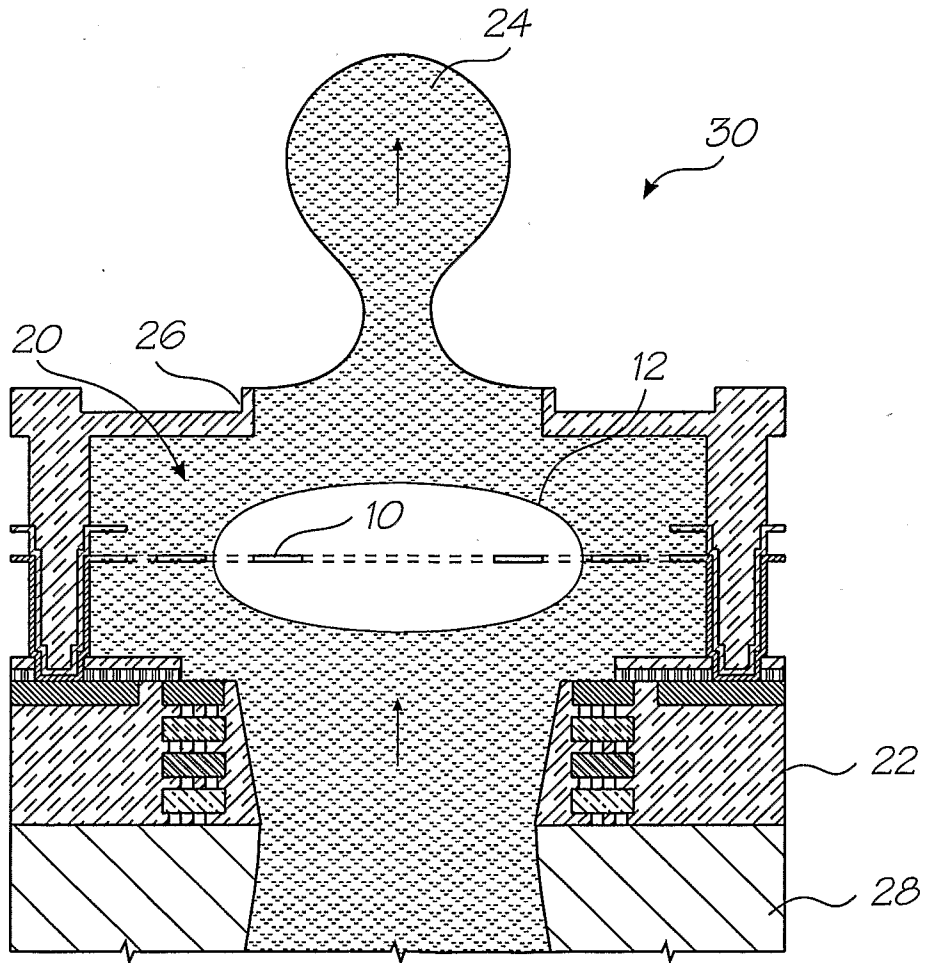

FIG. 5

## INTERNATIONAL SEARCH REPORT

International application No.

PCT/AU2006/001477

A. CLASSIFICATION OF SUBJECT MATTER		
Int. Cl.		
<b>B81B 7/02 (2006.01) B41J 2/05 (2006.01)</b>		
According to International Patent Classification (IPC) or to both national classification and IPC		
B. FIELDS SEARCHED		
Minimum documentation searched (classification system followed by classification symbols)		
Documentation searched other than minimum documentation to the extent that such documents are included in the fields searched		
Electronic data base consulted during the international search (name of data base and, where practicable, search terms used) dwp, esp@cenet IPC: B41J-002, B81B & keywords: MEMS, HEATER, ELECTRIC, PULSE, NUCLEATE, VAPOR, BUBBLE and other terms.		
C. DOCUMENTS CONSIDERED TO BE RELEVANT		
Category*	Citation of document, with indication, where appropriate, of the relevant passages	Relevant to claim No.
X	US 6296350 B1 (CORNELL ET AL) 2 October 2001 See whole document, especially abstract, Figs. 2-6, 15, column 2 line 35 – column 4 line 26 and column 8 line 58 – column 9 line 57.	1-12
X	US 4746937 A (REALIS LUC ET AL) 24 May 1988 See whole document, especially abstract, Figs. 1-8, column 2 line 43 – column 4 line 19.	1-12
A	US 5886716 A (HEINZL ET AL) 23 March 1999 See whole document	
<input type="checkbox"/> Further documents are listed in the continuation of Box C <input checked="" type="checkbox"/> See patent family annex		
* Special categories of cited documents:		
"A" document defining the general state of the art which is not considered to be of particular relevance	"T" later document published after the international filing date or priority date and not in conflict with the application but cited to understand the principle or theory underlying the invention	
"E" earlier application or patent but published on or after the international filing date	"X" document of particular relevance; the claimed invention cannot be considered novel or cannot be considered to involve an inventive step when the document is taken alone	
"L" document which may throw doubts on priority claim(s) or which is cited to establish the publication date of another citation or other special reason (as specified)	"Y" document of particular relevance; the claimed invention cannot be considered to involve an inventive step when the document is combined with one or more other such documents, such combination being obvious to a person skilled in the art	
"O" document referring to an oral disclosure, use, exhibition or other means	"&" document member of the same patent family	
"P" document published prior to the international filing date but later than the priority date claimed		
Date of the actual completion of the international search 04 December 2006	Date of mailing of the international search report 11 DEC 2006	
Name and mailing address of the ISA/AU AUSTRALIAN PATENT OFFICE PO BOX 200, WODEN ACT 2606, AUSTRALIA E-mail address: pct@ipaaustralia.gov.au Facsimile No. (02) 6285 3929	Authorized officer <b>BAYER MITROVIC</b> Telephone No : (02) 6283 2164	

## INTERNATIONAL SEARCH REPORT

Information on patent family members

International application No.

PCT/AU2006/001477

This Annex lists the known "A" publication level patent family members relating to the patent documents cited in the above-mentioned international search report. The Australian Patent Office is in no way liable for these particulars which are merely given for the purpose of information.

Patent Document Cited in Search Report		Patent Family Member					
US	6296350	CN	1194206	EP	0867286	EP	1514687
		JP	10291315				
US	4746937	EP	0205243	JP	62005856		
US	5886716	DE	4428807	GB	2292117		
<p>Due to data integration issues this family listing may not include 10 digit Australian applications filed since May 2001.</p> <p style="text-align: right;">END OF ANNEX</p>							