



(86) Date de dépôt PCT/PCT Filing Date: 2012/03/15
 (87) Date publication PCT/PCT Publication Date: 2012/09/20
 (85) Entrée phase nationale/National Entry: 2013/09/05
 (86) N° demande PCT/PCT Application No.: EP 2012/054617
 (87) N° publication PCT/PCT Publication No.: 2012/123559
 (30) Priorité/Priority: 2011/03/16 (DE10 2011 001 305.9)

(51) Cl.Int./Int.Cl. *H02M 7/48* (2007.01)
 (71) Demandeur/Applicant:
SMA SOLAR TECHNOLOGY AG, DE
 (72) Inventeurs/Inventors:
EBERHARDT, THOMAS, DE;
PETSCHENKA, JOSEF, DE;
KRAUSE, CHRISTOPHER, DE;
LANDAU, CHRISTIAN, DE
 (74) Agent: IPAXIO S.E.N.C.

(54) Titre : ONDULEUR COUPLE AU RESEAU, ENSEMBLE D'ONDULEURS ET PROCEDE PERMETTANT DE FAIRE
FONCTIONNER UN ENSEMBLE D'ONDULEURS
 (54) Title: GRID-CONNECTED INVERTER, INVERTER ARRANGEMENT AND METHOD FOR OPERATING AN
INVERTER ARRANGEMENT

Fig. 1

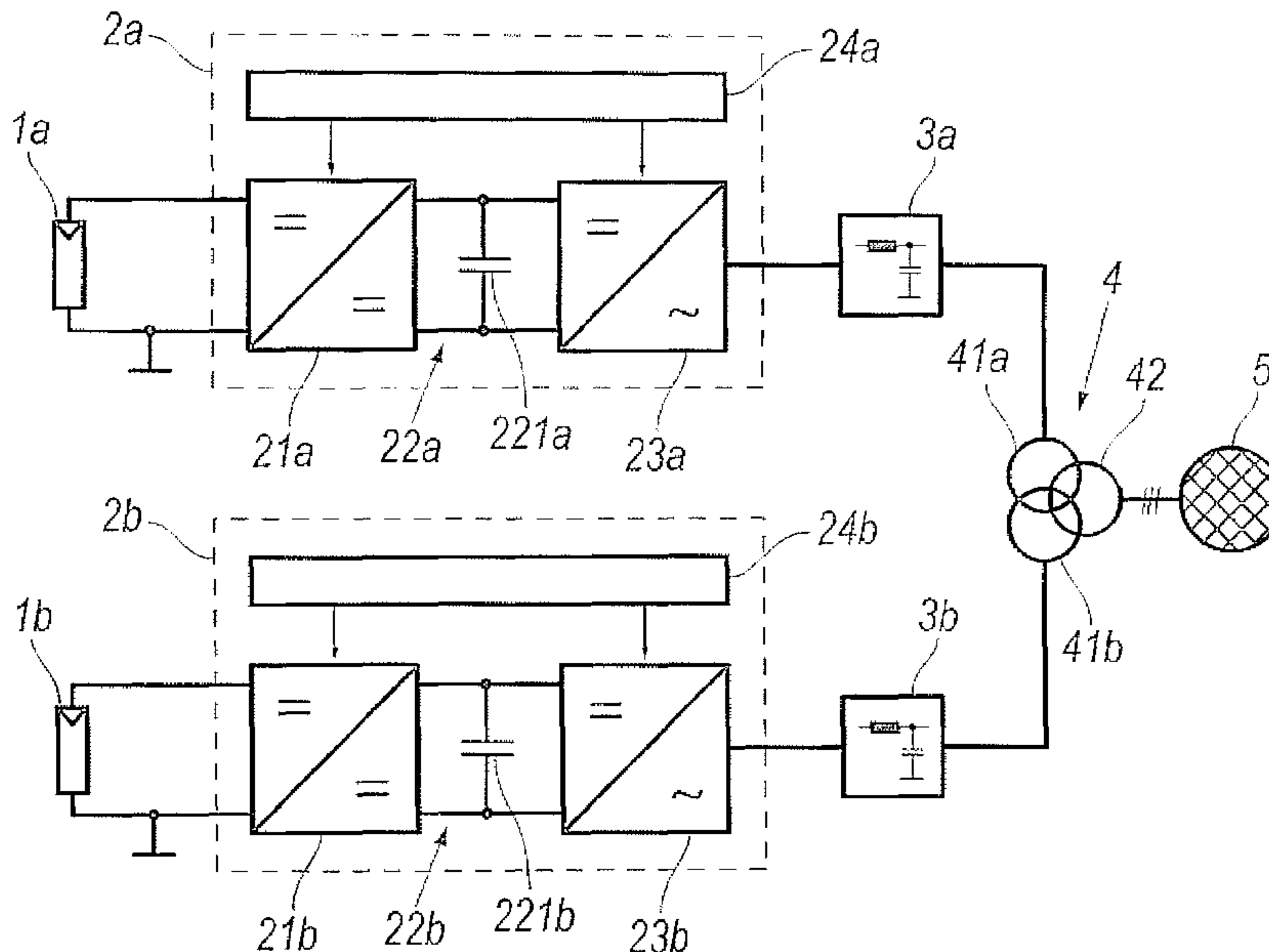

(57) Abrégé/Abstract:

The invention relates to a mains-coupled inverter (2) for feeding current into an energy supply network (5) via a transformer (4), which inverter has an output bridge arrangement which is driven via a pulse width modulator (241), wherein a periodic auxiliary signal is used to determine switching times of the output bridge arrangement. The inverter (2) also has a synchronization unit (241) for synchronizing the phase of the auxiliary signal with the energy supply network (5). The inverter (2) is distinguished by the fact that the synchronization unit (241) is set up to set a predefined phase offset (φ_0) of the periodic auxiliary signal with respect to a phase of the energy supply network (5). The invention also relates to an inverter arrangement having at least two such mains-coupled inverters (2) which are inductively coupled to one another on the AC side, and to a method for operating an inverter arrangement.

ABSTRACT

The invention relates to a grid-connected inverter (2) for feeding current into an electric power grid (5) via a transformer (4), which inverter has an output bridge arrangement which is driven via a phase modulator (241), wherein a periodic auxiliary signal is used to determine switching times of the output bridge arrangement. The inverter (2) also has a synchronization unit (241) for synchronizing the phase of the auxiliary signal with the electric power grid (5). The inverter (2) is distinguished by the fact that the synchronization unit (241) is set up to set a predefined phase offset ($\Delta\Phi_0$) of the periodic auxiliary signal with respect to a phase of the electric power grid (5). The invention also relates to an inverter arrangement having at least two such grid-connected inverters (2) which are inductively coupled to one another on the AC side, and to a method for operating an inverter arrangement.

**Grid-connected inverter, inverter arrangement and method for
operating an inverter arrangement**

5 The invention relates to a grid-connected inverter for feeding
current into an electric power grid via a transformer, wherein
the inverter comprises an output bridge circuit that is
actuated via a pulse width modulator, wherein a periodic
auxiliary signal is used to determine switching times of the
10 output bridge arrangement. The invention furthermore relates to
an arrangement comprising at least two such inverters and a
method for operating such an inverter arrangement.

Grid-connected inverters are used in energy supply systems, for
15 example photovoltaic systems and wind energy installations. In
grid-connected inverters, a voltage or current profile output
at the output of the inverter follows the corresponding profile
of the electric power grid. In the energy supply systems,
generators, for example photovoltaic modules connected in
20 series and/or parallel, generate a DC voltage, which is
supplied to a DC voltage intermediate circuit, possibly after a
change in voltage by a step-up converter. Direct current from
the DC voltage intermediate circuit is converted into an
alternating current that is suitable in terms of its frequency
25 and voltage for feeding into the electric power grid by the
inverter. This conversion can take place into a single-phase or
multiphase alternating current, in particular three-phase
alternating current. In this case, the inverter comprises an
output bridge circuit which comprises one or more switching
30 bridges which are generally equipped with power semiconductor
switches, depending on the number of phases of the electric
power grid into which it is intended to be fed in.

In this case, the power semiconductor switches are actuated in
35 accordance with a specific modulation pattern in such a way
that, in combination with filters which are arranged between

the inverter and the electric power grid, an output current is generated which is as sinusoidal as possible. In pulse width modulation methods (PWM), which are often used, the power semiconductor switches are switched on and off with a switching
5 frequency that is considerably higher than the frequency of the AC voltage in the electric power grid (for example a switching frequency of 3 to 30 kHz in comparison with a mains frequency of 50 or 60 Hz). Over the course of a period of the system frequency, in this case the ratio between the switch-on time
10 and the switch-off time within a switching frequency period, referred to as the duty factor, is changed in such a way that a profile of the output current as sinusoidal as possible is provided. Known configurations for determining the duty factors or the switching times are, for example, the "sine-triangle
15 modulation method", the "space vector modulation method" (SVM) or modified sine-triangle modulation methods, for example the so-called "third-harmonic sine-triangle modulation method". In these PWM methods, a periodic auxiliary signal, for example a triangular signal in the "sine-triangle modulation method" or a
20 clock signal in the "SVM method" is used for determining the switching times.

Even in the case of relatively complex modulation methods, however, the AC voltage generated is typically not a purely
25 sinusoidal signal, but shows, for example, frequency components at the switching frequency of the modulation method, which are referred to as voltage ripples.

In order to achieve relatively high output currents or powers,
30 in particular in the case of relatively large photovoltaic systems often two or more inverters are used in parallel. When these inverters are not completely isolated from one another on the output voltage side, compensation currents can occur between the inverters, which result in undesirable additional
35 current loading for the power semiconductor switches of the output bridge circuit of the inverters. Such output currents

occur, for example, when inverters are connected to one another both on the DC voltage side via a common intermediate circuit and on the AC voltage side, for example since they are connected directly to the electric power grid without a transformer interposed. On the DC voltage side, coupling can also be provided when no common intermediate circuit is used, but the modules or strings (a series connection of modules) are each grounded with one connection. On the AC voltage side, problematic mutual influencing of two inverters can also be provided via an inductive coupling. In a case of inductive coupling of two inverters, no DC compensation currents flow, but compensation currents with AC components at relatively high frequencies may flow, in particular due to the above-described voltage ripples which are not entirely avoidable during the inversion. Such a coupling can also be observed in installations in which transformers are arranged between the inverters and the electric power grid.

The document DE 10 2008 056 256 A1 shows an inverter arrangement having a plurality of inverters connected in parallel, in which compensation currents between the inverters can be avoided by virtue of the fact that corresponding power semiconductor switches of the individual inverters are actuated at the same time. This is achieved in that one of the inverters, referred to as the master inverter, generates actuation signals for the power semiconductors which are transmitted via corresponding lines to each of the further inverters, which are referred to as slave inverters. However, this method is only practicable in the case of inverters that are arranged physically close to one another.

Document US 2008/0265680 A1 describes an arrangement of a plurality of inverters that are coupled directly with their outputs. The inverters are controlled by PWM methods, wherein the auxiliary signals used in the process are synchronized using a grid voltage. As a result, transmission of actuation

signals for the output bridge arrangement of the inverters is not necessary. The electric power grid is used as a synchronization connection. The method is well suitable for directly interconnected inverters. In the case of inverters
5 that are coupled inductively, for example via transformers, however, it has been demonstrated that compensation currents are not completely suppressed.

Therefore one object of the present invention is to provide an
10 arrangement of inverters and a method for operating an arrangement of inverters in which inverters that are coupled to one another inductively via a transformer on the AC side can be operated without problematic compensation currents occurring and without transmission of actuation signals for the output
15 bridge arrangement of the inverters being necessary. A further object of the invention is to provide a grid-connected inverter suitable for this purpose.

This object is achieved by an inverter, an inverter arrangement
20 and a method for operating an inverter arrangement having the respective features of the independent claims. Advantageous configurations and developments are specified in the respective dependent claims.

25 In accordance with a first aspect, the object is achieved by a grid-connected inverter for feeding current into an electric power grid via a transformer, said inverter having an output bridge arrangement that is actuated via a pulse width modulator, wherein a periodic auxiliary signal is used to
30 determine switching times of the output bridge arrangement. Furthermore, the inverter comprises a synchronization unit for phase synchronization of the auxiliary signal with the electric power grid. The inverter is characterized in that the synchronization unit is designed to set a predetermined phase
35 offset of the periodic auxiliary signal with respect to a phase of the electric power grid.

By virtue of the phase synchronization of the auxiliary signal with the electric power grid, the switching times of two inverters can be matched to one another, with the result that
5 no compensation currents flow, wherein the phase offset makes it possible for phase shifts occurring within the transformer to be compensated for. As a result, even in the case of inductively coupled inverters, synchronization without transmission of actuation signals for the output bridge
10 arrangement of the inverters over the electric power grid can take place.

In an advantageous configuration of the inverter, the synchronization unit comprises a PLL (phase lock loop) circuit.
15 In this way, synchronization of the auxiliary signal with the electric power grid can take place in a simple manner, although the auxiliary signal generally has a frequency which is a multiple higher than the electric power grid.

20 In accordance with a second aspect, the object is achieved by an inverter arrangement comprising at least two such grid-connected inverters, which are coupled to one another on the AC side. The same advantages result as in the first aspect.

25 In a configuration of the inverter arrangement, the inverters are coupled inductively to one another on the AC side via a three-winding transformer. Three-winding transformers are considerably less complex and less costly than conventional four-winding transformers. The often disadvantageous low
30 impedance between the two primary windings in three-winding transformers is unproblematic owing to the use of the inverters in accordance with the first aspect. In this case, the impedances of the primary windings can also be different, since asymmetries can be compensated for by the method applied.

35

In another embodiment of the present invention, the object is achieved by an operating method for an inverter arrangement for feeding power into an electric power grid with at least two grid-connected inverters, wherein the inverters are coupled to one another on the AC side by at least one transformer and each inverter comprises an output bridge arrangement that is actuated in pulse-width-modulated fashion using a periodic auxiliary signal, wherein the respective periodic auxiliary signal is phase-synchronized with the electric power grid. The operating method is characterized in that the periodic auxiliary signals of the two coupled inverters have a predetermined non-zero phase offset with respect to one another. The advantages in turn correspond to those of the first and second aspects.

15

The invention will be illustrated below with reference to seven figures in exemplary embodiments. In the figures:

figure 1 shows a schematic block circuit diagram of an energy supply device with two inverters,

20

figure 2 shows a representation of output voltages over time of the two inverters from the exemplary embodiment shown in figure 1 in the unsynchronized case,

25

figure 3 shows part of an inverter in a schematic overview illustration in a schematic block circuit diagram,

30

figure 4 shows a representation of output voltages over time in the case of inverters which are not coupled inductively in a synchronized case,

figure 5 shows a synchronization device which can also be used for inductively coupled inverters for an inverter in a schematic block circuit diagram, and

5 figure 6 shows a simplified equivalent circuit diagram of a three-winding transformer, and

figure 7 shows a phasor diagram relating to the equivalent circuit diagram illustrated in figure 6.

10

Figure 1 depicts a photovoltaic system as energy supply system in a schematic block circuit diagram. The photovoltaic system, referred to as PV system below for short, comprises two photovoltaic generators (PV generators) 1a, 1b, which are each
15 connected to an inverter 2a, 2b. The output of the inverter is connected to a transformer 4 via a filter 3a, 3b, respectively. The transformer 4 comprises two separate primary windings 41a, 41b for this purpose. A common secondary winding 42 of the transformer 4 is connected to an electric power grid 5 for
20 feeding the electrical power, which has been generated by the PV generators 1a, 1b and has been converted in the inverters 2a, 2b, into said electric power grid.

The PV generators 1a, 1b are in each case illustrated only by
25 the circuit symbol for an individual photovoltaic cell symbolically in the figure. Needless to say that the PV generators 1a, 1b can be constructed with an embodiment of the PV system illustrated in each case from a plurality of photovoltaic modules (PV modules), which are connected to one
30 another in series and/or in parallel. For reasons of clarity further elements of PV systems, for example DC-side switching elements or AC-side switching elements, for example disconnectors or fuse elements, are not depicted in the figure.

35 In the illustrated embodiment of the invention, the inverters 2a, 2b each comprise an input-side DC-to-DC converter 21a, 21b,

which is connected in each case to a DC-to-AC inverter 23a, 23b via an intermediate circuit 22a, 22b. It is noted that an inverter in accordance with the application can also be constructed without an input-side DC-to-DC converter. In each case a capacitor 221a, 221b is arranged in the intermediate circuit, said capacitor being used for smoothing the intermediate circuit voltage U_z and enabling a pulsed current withdrawal without voltage dips in the intermediate circuit voltage U_z by virtue of the DC-to-AC inverter 23a, 23b. The inverters 2a, 2b each have a control device 24a, 24b for controlling the DC-to-DC converters 21a, 21b and the DC-to-AC inverters 23a, 23b. The control of the DC-to-DC converters 21a, 21b may in this case also comprise a so-called MPP (Maximum Power Point) tracking method, for example, which is used for operating the PV generators 1a, 1b at a maximum power working point.

The PV system is designed for feeding electric power into the electric power grid 5 on three phases. Correspondingly, the inverters 2a, 2b have a three-phase output, and the filters 3a and 3b and the transformer 4 are designed for three phases. The number of three phases should be understood to be merely exemplary; an inverter in accordance with the application and an inverter arrangement constructed therewith can likewise be suitable for operation with any desired number of phases, in particular single-phase operation.

The inverters 2a, 2b have output bridge circuits with semiconductor power switches in their DC-to-AC inverters 23a, 23b, said semiconductor power switches being actuated in a PWM method. The output signal of the DC-to-AC inverters 23a, 23b is therefore a clocked DC signal, wherein the clock frequency, i.e. the number of switching cycles per second, can be in the range of one kilohertz to a few 10 kilohertz. The filters 3a, 3b, which comprise a combination of inductive and capacitive elements, are used for smoothing the output signal of the

inverters 2a, 2b to give a voltage profile which is as sinusoidal as possible. For this reason, they are often also referred to as sine-wave filters.

5 Figure 2 shows, in its upper part, the voltages U_a and U_b at the output of the filters 3a, 3b normalized to an amplitude voltage U_0 as a function of time t . The figure illustrates the profile of a period of a phase of the electric power grid 5 with a period length t_0 . Figure 2 shows non-synchronized operation of
10 the inverters 2a, 2b. The profiles of the voltages U_a , U_b both show a component with a relatively high frequency which is superimposed on the purely sinusoidal profile. In terms of its amplitude, this component equates to a few percentage points of the amplitude voltage U_0 . These components with a relatively
15 high frequency are also referred to as voltage ripples.

In the lower part of figure 2, a differential voltage $\Delta U = U_b - U_a$ is illustrated on the same time axis as in the upper part of the figure. With respect to the voltage axis, the lower part of
20 the figure is illustrated in enlarged form in comparison with the upper part of the figure. The profile of the voltage difference ΔU which fluctuates about the zero point shows that the two inverters 2a, 2b uniformly follow the voltage profile of the electric power grid 5 with respect to the sinusoidal
25 fundamental. A differential voltage ΔU other than zero can be observed with the voltage ripples, however. During operation of the PV system, this differential voltage ΔU , owing to inductive coupling of the currents in the primary windings 41a, 41b of the transformer 4, result in compensation currents at the
30 frequency of the voltage ripples which flow back and forth between the capacitors in the filters 3a, 3b. This can be observed in particular when a so-called three-winding transformer is used as the transformer 4, which three-winding transformer has a lower impedance between the two primary
35 windings than other suitable transformers, for example the so-called four-winding transformers.

Figure 3 shows a detail of one of the inverters 2a, 2b from figure 1, likewise in a block circuit diagram. The following statements relate to both inverters 2a, 2b which have an identical construction in the exemplary embodiment illustrated. Therefore, no distinction is drawn using the index a, b in the reference symbols.

The DC-to-AC inverter 23 of the inverter 2 comprises an output bridge arrangement, of which one bridge branch is illustrated symbolically. In the case of a three-phase embodiment of the inverter 2, generally three such bridge branches are provided, which are indicated by the ellipses in the figure. Each bridge branch comprises two semiconductor power switches 231, 232. By way of example, IGBTs (Insulated-Gate Bipolar Transistors) are illustrated, each IGBT is provided with a protection diode connected back-to-back in parallel (anti-parallel). However, other suitable semiconductor switches, for example MOSFETs (Metal Oxide Semiconductor Field-Effect Transistors) can also be used. The switches 231, 232 are actuated by the control device 24. Said control device comprises a pulse width modulator 241, a reference voltage generator 242, a synchronization unit 243 and a control unit 244.

The pulse width modulator 241 generates the actuation signals for the switching elements 231, 232 in such a way that a predetermined profile of a reference voltage U_{ref} is reproduced. The reference voltage U_{ref} is formed by the reference voltage generator 242 from a grid voltage profile supplied thereto of the electric power grid 5. Therefore, the voltage profile output at the output of the inverter 2 follows that of the grid voltage; the inverter is grid-connected. The reference voltage generator 242 can, in order to provide the reference voltage U_{ref} , map the voltage of one of the phases of the electric power grid, referred to below as the grid voltage U_{grid} , onto a lower voltage level of the reference voltage U_{ref} . The mapping can take

place directly or, alternatively, by using an intermediate reference voltage sine-wave generator that is synchronized with the predetermined grid voltage U_{grid} via a phase lock loop (PLL).

5 The pulse width modulator 241 in the exemplary embodiment illustrated is a triangle-sine wave modulator. With this type of modulation, a triangular signal U_{Δ} is used as periodic auxiliary signal for determining the switching points of the switches 231, 232. The frequency of the triangular signal U_{Δ} is
10 a multiple of the frequency f_0 of the grid voltage U_{grid} . In the exemplary embodiment illustrated, the triangular signal U_{Δ} used as periodic auxiliary signal is generated by the synchronization unit 243.

15 Figure 4 shows, in the same way as figure 2, output voltages U_a and U_b of two inverters, whose respective auxiliary signal has been adjusted to an identical phase angle in respect of the voltage profile of one of the phases of an electric power grid. It can be seen in the upper part of figure 4 that the voltage
20 profiles U_a and U_b are congruent on the scale illustrated. This is confirmed by the representation of the differential voltage $\Delta U = U_b - U_a$ in the lower part of the figure, in which only a minimum discrepancy with respect to the zero line can be seen. Disadvantageous compensation currents which would occur in the
25 case of direct coupling of the outputs are therefore no longer or virtually no longer present during synchronization of the triangular signal U_{Δ} with the same phase angle.

If, however, the inverters are not coupled directly, but are
30 coupled inductively as in the exemplary embodiment in figure 1, such a synchronization with a common phase angle over one of the phases in the electric power grid cannot prevent AC compensation currents from flowing.

35 In accordance with the method according to the application for operating an inverter arrangement, a predetermined phase

relationship between the periodic auxiliary signal, in this case the triangular signal U_{Δ} , and the grid voltage U_{grid} , represented by the reference voltage U_{ref} , for the inverters of the inverter arrangement is adjusted in such a way that the auxiliary signals of two coupled inverters can have a predetermined phase offset $\Delta\Phi_0$ other than zero with respect to one another. In the exemplary embodiment described here, this is performed by the synchronization unit 243.

Figure 5 shows the structure of the synchronization unit 243 from figure 4 in more detail in a block circuit diagram. It is noted in advance that figure 5 illustrates a synchronization unit with an analog control loop for the phase angle of the auxiliary signal for the PWM. Needless to say that the synchronization unit can likewise have digital closed-loop control.

The synchronization unit comprises a triangular voltage generator 200, which is in the form of a voltage-controlled frequency generator whose frequency f is controlled via an input voltage signal U_f . The voltage signal output by the triangular voltage generator 200 at an output is provided as triangular signal U_{Δ} to the pulse width modulator 241.

Within the synchronization unit, the triangular signal U_{Δ} is supplied to a frequency converter 201. The frequency f of the triangular signal U_{Δ} is generally an integral multiple of the mains frequency f_0 of the electric power grid 5. The frequency ratio f/f_0 between the two frequencies is preferably in the range of approximately 10 to 100. In order to perform a comparison of the phase angles of the triangular signal U_{Δ} and the lower-frequency grid voltage profile, the frequency converter 201 implements frequency division of the triangular signal U_{Δ} by said factor, and waveform conversion into a sinusoidal signal. One possibility for the conversion consists in installing a ring counter with a counter content incremented

by the value $1/\text{per}$ passed-through period of the triangular signal U_{Δ} . If the counter reaches a count which corresponds to the frequency ratio f/f_0 , the counter is reset to an initial value of 1. The counter thus passes cyclically through f/f_0 different values, wherein each cycle run corresponds to a period duration of the sinusoidal signal of the grid voltage U_{grid} . A conversion table is stored in the frequency converter 201, in which a corresponding value for a sinusoidal voltage with the period duration of the mains frequency f_0 is stored for each count. A voltage signal generated by means of a digital-to-analog converter is output in accordance with the values in this table at the output of the frequency converter 201. Thus, the frequency converter 201 provides a sinusoidal voltage signal at its output, which sinusoidal voltage signal is coupled, with a phase lock, to the triangular signal U_{Δ} of the triangle-wave generator 200 and corresponds in terms of its frequency to the grid voltage U_{grid} . This signal is likewise supplied to a phase comparator 202, in the same way as the reference signal U_{ref} which is provided by the reference generator 242 and is phase-locked with respect to the grid voltage. A signal $U_{\Delta\Phi}$ is output at the output of the phase comparator 202, which signal is proportional to the phase difference between the two input signals. A voltage generated by an offset adjuster 204 and which corresponds to a phase offset $\Delta\Phi_0$ to be adjusted is also added to this signal in an adder 203. The total signal is supplied to a closed-loop control module 205 as controlled variable, said closed-loop control module possibly being in the form of a proportional-integral controller (PI controller). The output of the closed-loop control module 205 is added in a further adder 206 to a fundamental voltage U_{f0} , which is output by a fundamental frequency adjuster 207 in order to generate the control voltage U_f , which controls the frequency f of the triangle-wave generator 200, as described at the outset.

The synchronization unit 243 thus comprises a phase lock loop (PLL), by means of which the frequency f of the triangle-wave generator 200 is continuously adjusted via the closed-loop control module 205 in such a way that a fixed phase relationship between the triangular signal U_{Δ} and the reference voltage U_{ref} prevails. This phase relationship can in this case be adjusted via the offset adjuster 204 or else predetermined by a control device. The frequency ratio f/f_0 between the triangular signal U_{Δ} and the grid voltage U_{grid} is determined via the frequency divider 201 and the conversion table stored therein. In this case, the input of the fundamental voltage U_{f0} by the fundamental frequency adjuster should be matched correspondingly, with the result that the fundamental is already as close as possible to the operating frequency of the triangle-wave generator 200 even when the control loop is switched on.

A method for determining a phase offset $\Delta\Phi_0$ will now be described with reference to figures 6 and 7, said method preventing compensation currents from flowing owing to voltage ripples on the output voltage of the inverters in the case of inductive coupling of two inverters.

Figure 6 shows in this respect a simplified equivalent circuit diagram of the three-winding transformer 4 from the exemplary embodiment in figure 1. In this simplified equivalent circuit diagram, both nonreactive resistors of the primary windings 41a, 41b and the secondary winding 42 and the main inductance of the transformer 4 are not taken into consideration.

The stray inductances 43a, 43b of the primary windings 41a and 41b, respectively, which are relevant for the inductive coupling and a stray inductance 44 of the secondary winding 42 are specified. The voltages U_a and U_b are present at the inputs of the transformer 4 which are connected to the stray inductances 43a, 43b. The grid voltage U_{grid} is correspondingly

present at the stray inductance 44. Furthermore, figure 6 indicates the currents I_a and I_b flowing at the inputs and a voltage U_{ab} which is applied to the node between the stray inductances 43a, 43b and 44.

5

During operation of the transformer 4 illustrated, the currents I_a , I_b in conjunction with the reactances of the stray impedance 43a, 43b result in a voltage drop U_a^x and U_b^x across the stray impedances 43a, 43b.

10

Compensation currents between the inverters are prevented when the corresponding input voltages U_a and U_b and the corresponding voltage drops U_a^x and U_b^x are added to give the same node voltage U_{ab} in each of the sub branches from the input of the transformer 4 up to said node, i.e. when $U_a - U_a^x = U_b - U_b^x$, wherein it is necessary to take into consideration the fact that the input voltages and the voltage drops across the stray impedances 43a, 43b are perpendicular to one another in a complex representation.

20

In figure 7, this condition is reproduced in the form of a phasor diagram. The voltage drops U_a^x and U_b^x result in phase differences $\Delta\Phi_a$ and $\Delta\Phi_b$ of the input voltage U_a and U_b with respect to the node voltage U_{ab} . The phase shifts $\Delta\Phi_a$, $\Delta\Phi_b$ are generally different since the magnitude of the voltage drops U_a^x and U_b^x is also different. This results as a product of the current I_a or I_b and the reactance of the respective stray inductance 43a or 43b. The reactance is in turn proportional to the magnitude of the inductance value of the stray inductance 43a, 43b for the predetermined mains frequency. By way of summary, this means that, firstly, the power fed by an inverter determines the magnitude I_a , I_b , and secondly the properties of the transformer 4 are responsible for the phase differences $\Delta\Phi_a$ and $\Delta\Phi_b$. With respect to the transformer 4, in particular the differences in the properties of the individual windings 41a, 41b associated with the inverters are relevant. Feeding power

35

into the electric power grid without any compensation currents flowing between the inverters is achieved when a phase offset of $\Delta\Phi_0 = \Delta\Phi_a - \Delta\Phi_b$ is adjusted between the output voltages U_a and U_b .

5

In this case, besides the properties of the transformer, the electrical properties of a connection path between the inverter and the transformer can also be taken into consideration in order to compensate for the influences of said properties on phase differences. In this sense, possibly relevant properties of the connection path are the impedances of connecting lines and/or of interposed filters, for example.

10

Large photovoltaic power stations are often constructed from a plurality of PV systems as shown in figure 1. As previously described, the inverters 2 of each PV system are synchronized in order to avoid compensation currents. Advantageously, when interconnecting a plurality of PV systems at a mains connection point of the electric power grid 5, however, the PV systems are each synchronized in pairs in such a way that their respective voltage ripples are, as far as possible, in phase opposition (phase shift of 180°) and therefore the voltage ripples are mutually canceling. In the synchronization unit 243 shown in figure 5, this can also take place via the offset adjuster 204.

The inverters of a first PV system are operated in the same phase with a specific phase offset $\Delta\Phi_0$ in respect of their triangular voltage U_Δ , and the inverters of a second PV system are operated in turn with a specific phase offset $\Delta\Phi'_0$ with respect to one another in respect of their triangular voltage U_Δ , wherein there is a phase offset of approximately 180° between the inverters of the first and second PV systems, however.

20

25

30

In an alternative configuration, in a photovoltaic power station with a plurality of PV systems as described above, the inverters 2 of each PV system are synchronized in such a way that their outputs give voltage ripples with the same profile.

35

The individual PV systems are operated with predetermined phase offsets $\Delta\Phi_0$ other than zero which are preferably different and are distributed as uniformly as possible over the entire phase space (0 to 2π or 0-180°), however. This configuration is
5 suitable in particular for photovoltaic power stations which comprise an uneven number of PV systems.

List of reference symbols

	1	Photovoltaic generator (PV generator)
	2	Inverter
5	21	DC-to-DC converter
	22	Intermediate circuit
	221	Capacitor
	23	DC-to-AC inverter
	231, 232	Semiconductor power switch
10	24	Control device
	241	Phase modulator
	242	Reference voltage generator
	243	Synchronization unit
	244	Control unit
15	3	Filter
	4	Transformer
	41	Primary winding
	42	Secondary winding
	5	Electric power grid
20	200	Triangle-wave generator
	201	Frequency divider
	202	Phase comparator
	203	Adder
	204	Offset adjuster
25	205	PI controller
	206	Adder
	207	Fundamental frequency adjuster

Claims

1. A grid-connected inverter (2) for feeding current via a transformer (4) into an electric power grid (5), comprising
 - an output bridge arrangement that is actuated via a pulse width modulator (241), wherein a periodic auxiliary signal is used to determine switching times of the output bridge arrangement, and
 - a synchronization unit (241) for phase synchronization of the auxiliary signal with the electric power grid (5),characterized in that the synchronization unit (241) is designed to set a predetermined phase offset ($\Delta\Phi_0$) of the periodic auxiliary signal with respect to a phase of the electric power grid (5).
2. The grid-connected inverter as claimed in claim 1, in which the pulse width modulator (241) is a sine-triangle modulator, and the periodic auxiliary signal is a triangular signal (U_Δ).
3. The grid-connected inverter as claimed in claim 1 or 2, in which the synchronization unit (241) comprises a PLL circuit.
4. The grid-connected inverter as claimed in claim 3, in which the PLL circuit comprises a frequency converter (201) with a conversion table and a DA converter for converting the periodic auxiliary voltage into a phase-locked sinusoidal voltage with a low frequency.
5. An inverter arrangement comprising at least two grid-connected inverters (2), which are coupled inductively to one another on the AC side, characterized in that the inverters (2) are designed according to one of claims 1 to 4.

6. The inverter arrangement as claimed in claim 5, in which the inverters (2) are coupled to one another on the AC side via a three-winding transformer (4).

7. The inverter arrangement as claimed in claim 6, in which the three-winding transformer (4) comprises two primary windings with different impedances.

8. An operating method for an inverter arrangement for feeding power into an electric power grid (5) with at least two grid-connected inverters (2) that are coupled to one another on the AC side via at least one transformer (4), each of the inverters (2) comprising an output bridge arrangement that is actuated in a pulse-width-modulated fashion using a periodic auxiliary signal, wherein the respective periodic auxiliary signal is phase-synchronized with the electric power grid (5), characterized in that the periodic auxiliary signals of the two coupled inverters (2) have a predetermined phase offset ($\Delta\Phi_0$) other than zero with respect to one another.

9. The operating method as claimed in claim 8, in which the phase offset ($\Delta\Phi_0$) is dependent on a power fed by the inverter (2) into the electric power grid (5).

10. The operating method as claimed in claim 8 or 9, in which the phase offset ($\Delta\Phi_0$) is dependent on the magnitude of an inductance and/or a resistance of a winding (41) of the transformer (4) which is connected to the inverter.

11. The operating method as claimed in one of claims 8 to 10, in which the phase offset ($\Delta\Phi_0$) is dependent on the magnitude of an inductance and/or a resistance of a connecting path between the inverter and the transformer (4).

12. The operating method as claimed in one of claims 8 to 11, in which at least four grid-connected inverters (2) are

provided that are coupled to one another in pairs of two on the AC side, wherein the predetermined non-zero phase offsets ($\Delta\Phi_0$) of the periodic auxiliary signals are different for the inverters (2) that are each coupled to one another in pairs on the AC side and the inverters (2) that are not coupled to one another.

13. The operating method as claimed in claim 12, in which the periodic auxiliary signals of inverters (2) that are not coupled to one another are in phase opposition.

14. The operating method as claimed in claim 12, in which the periodic auxiliary signals of all of the inverters (2) that are not coupled to one another have different phase offsets ($\Delta\Phi_0$).

Fig. 1

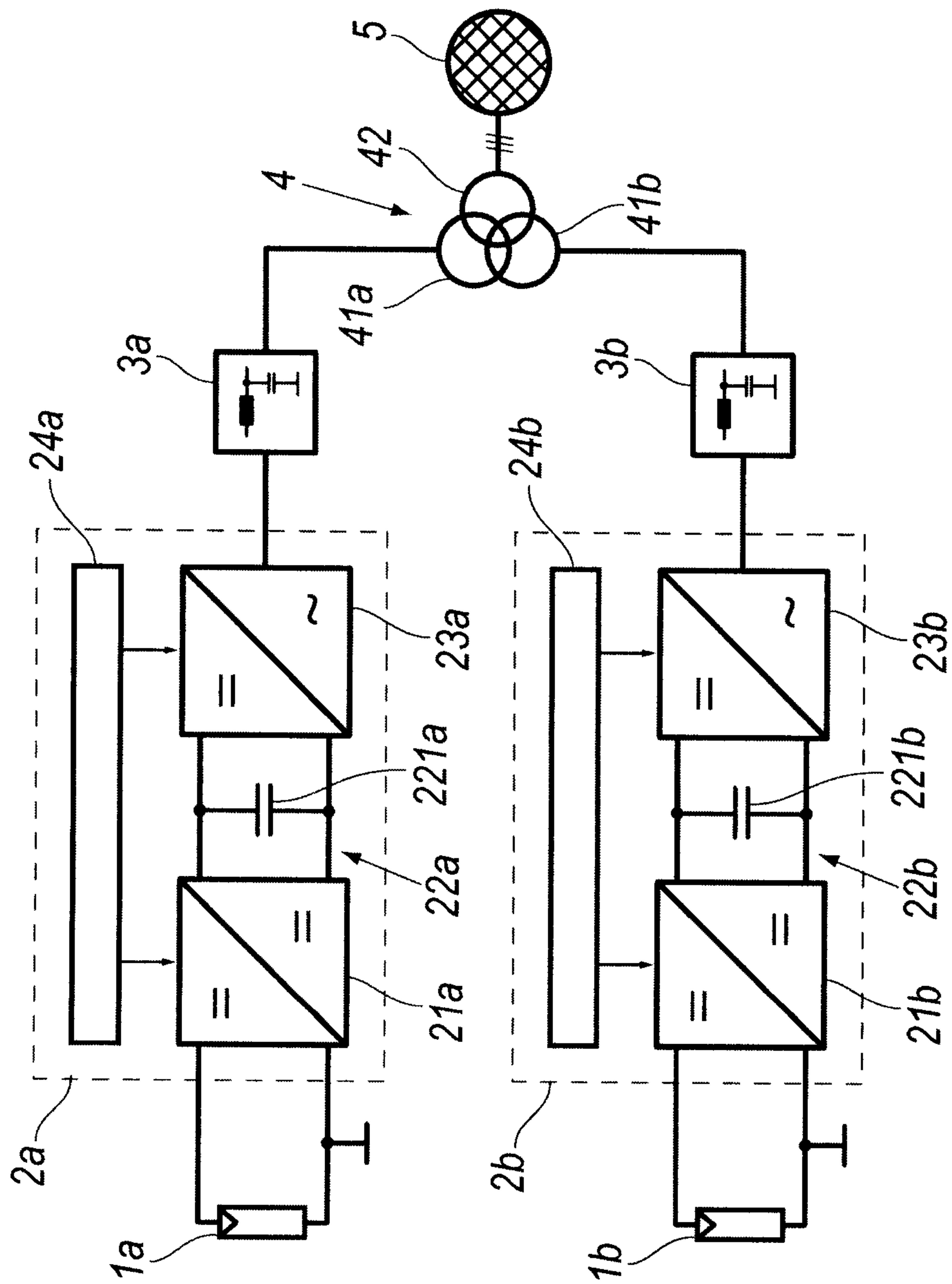

Fig. 2

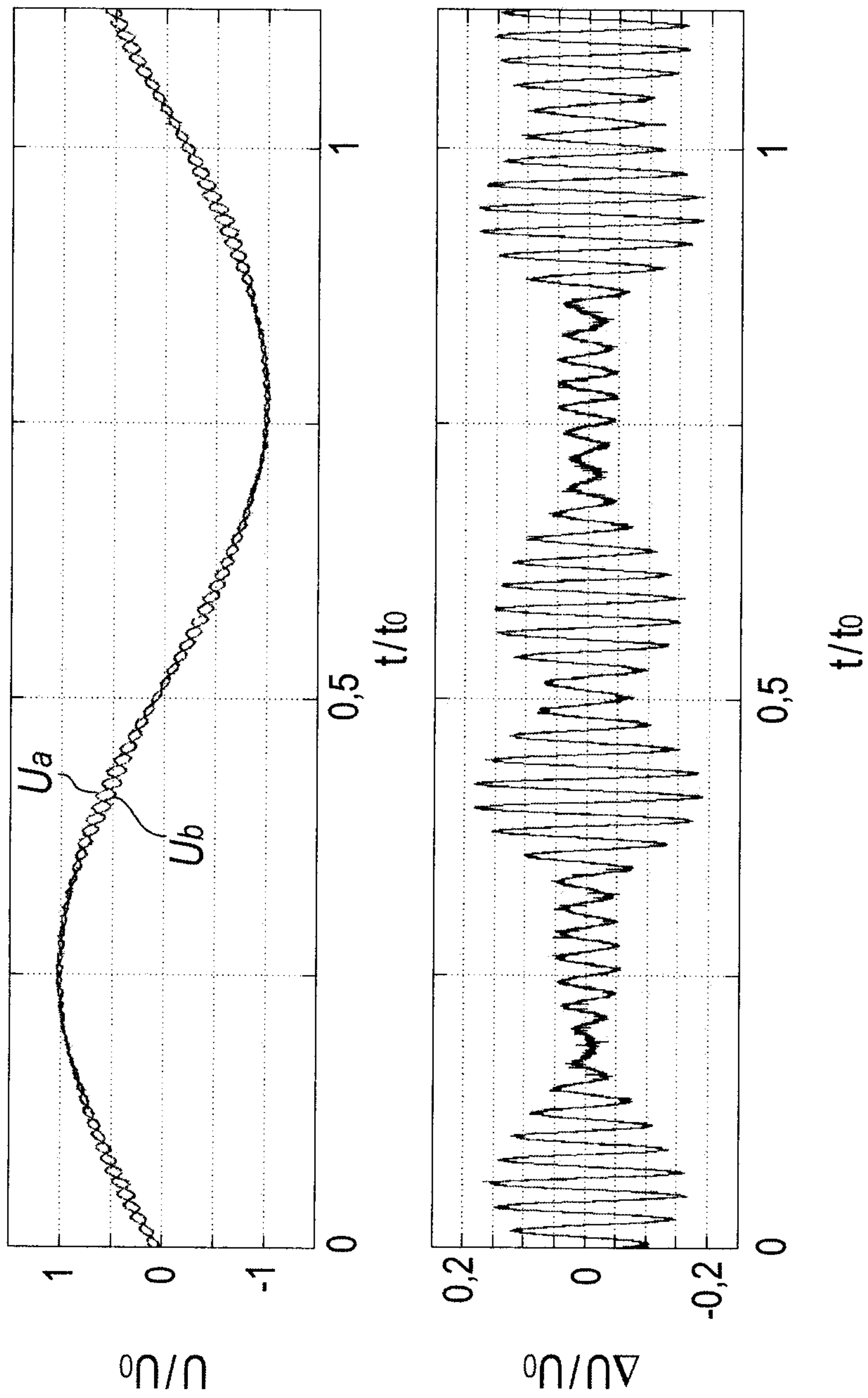

Fig. 3

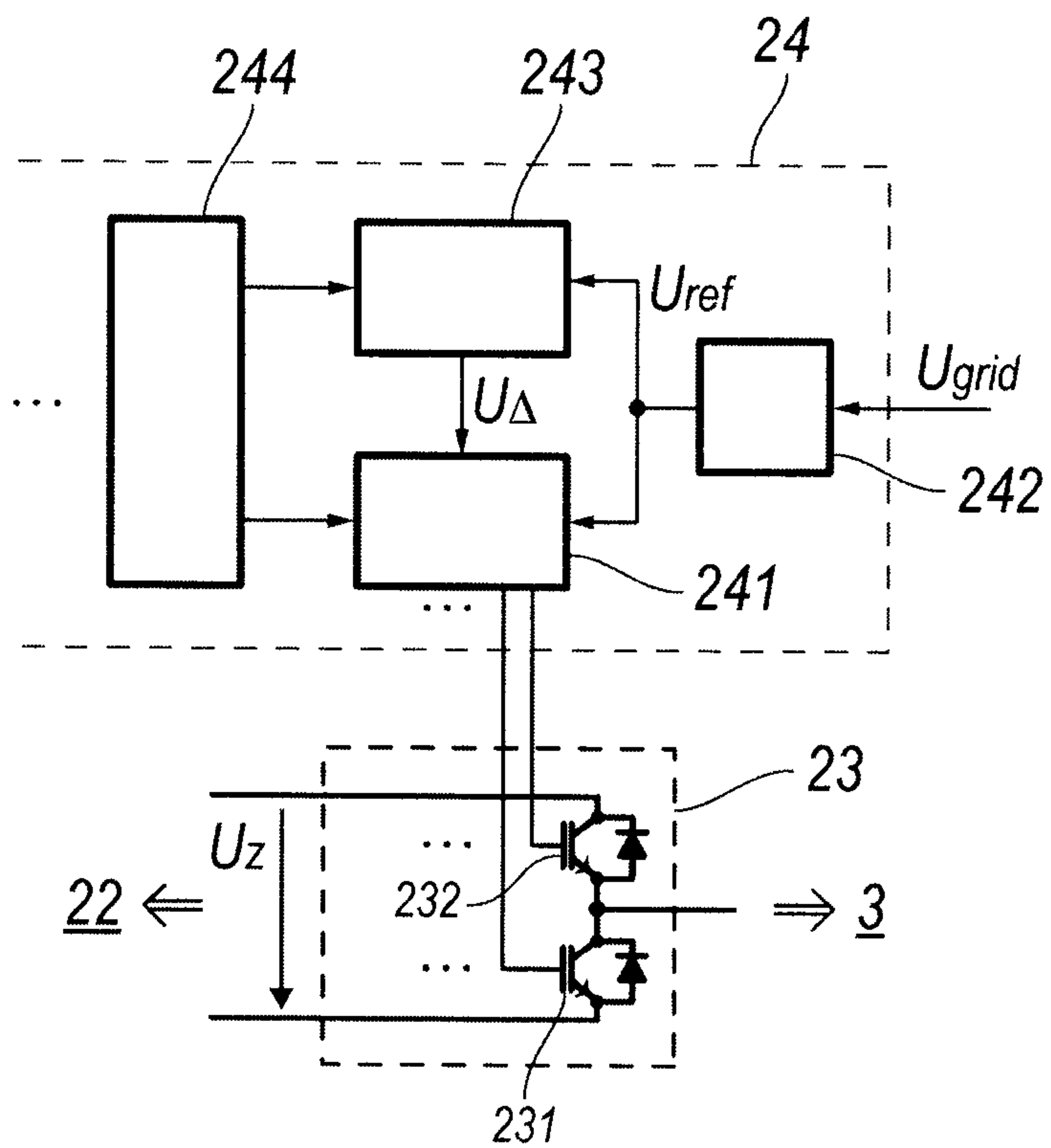

Fig. 4

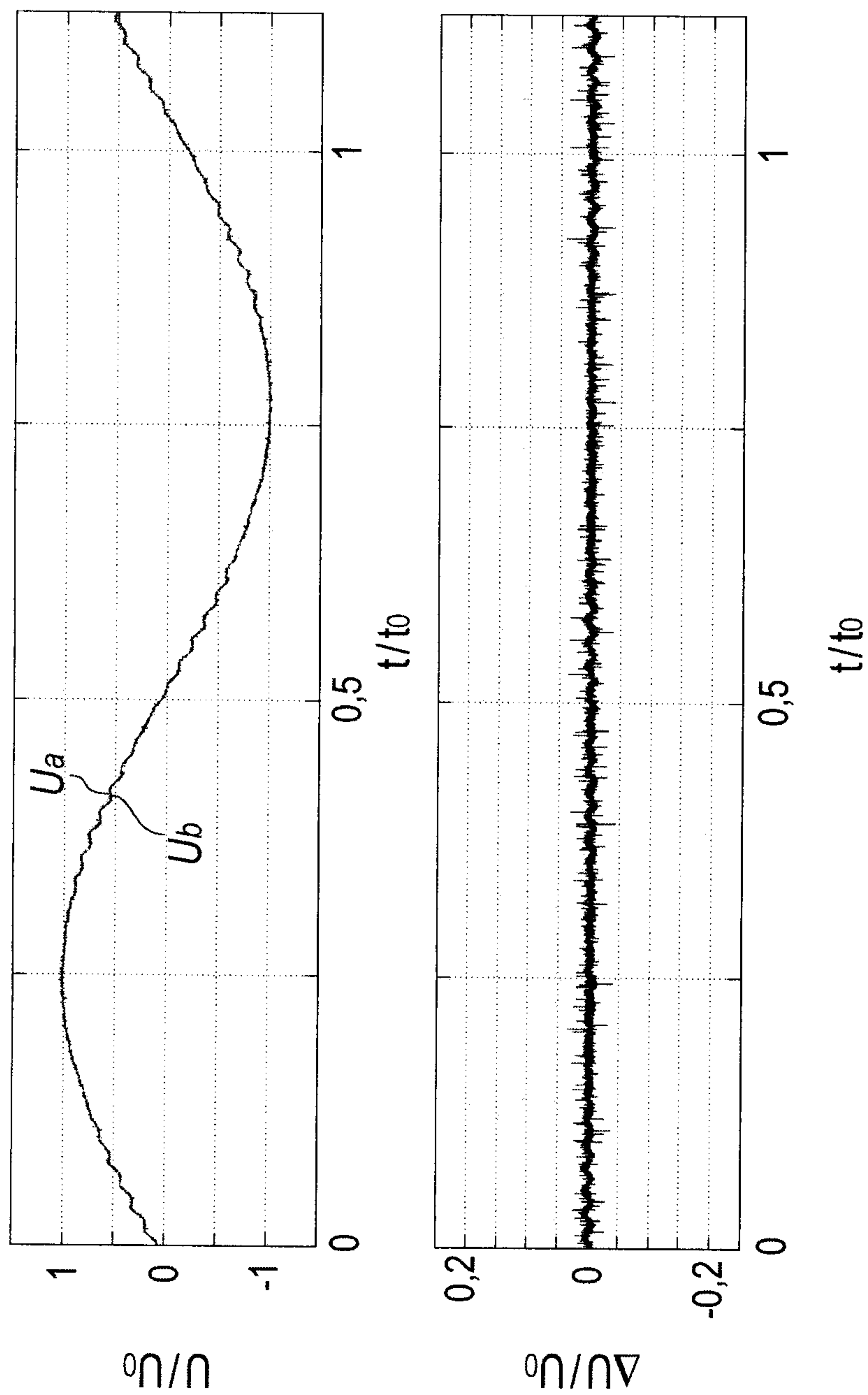

Fig. 5

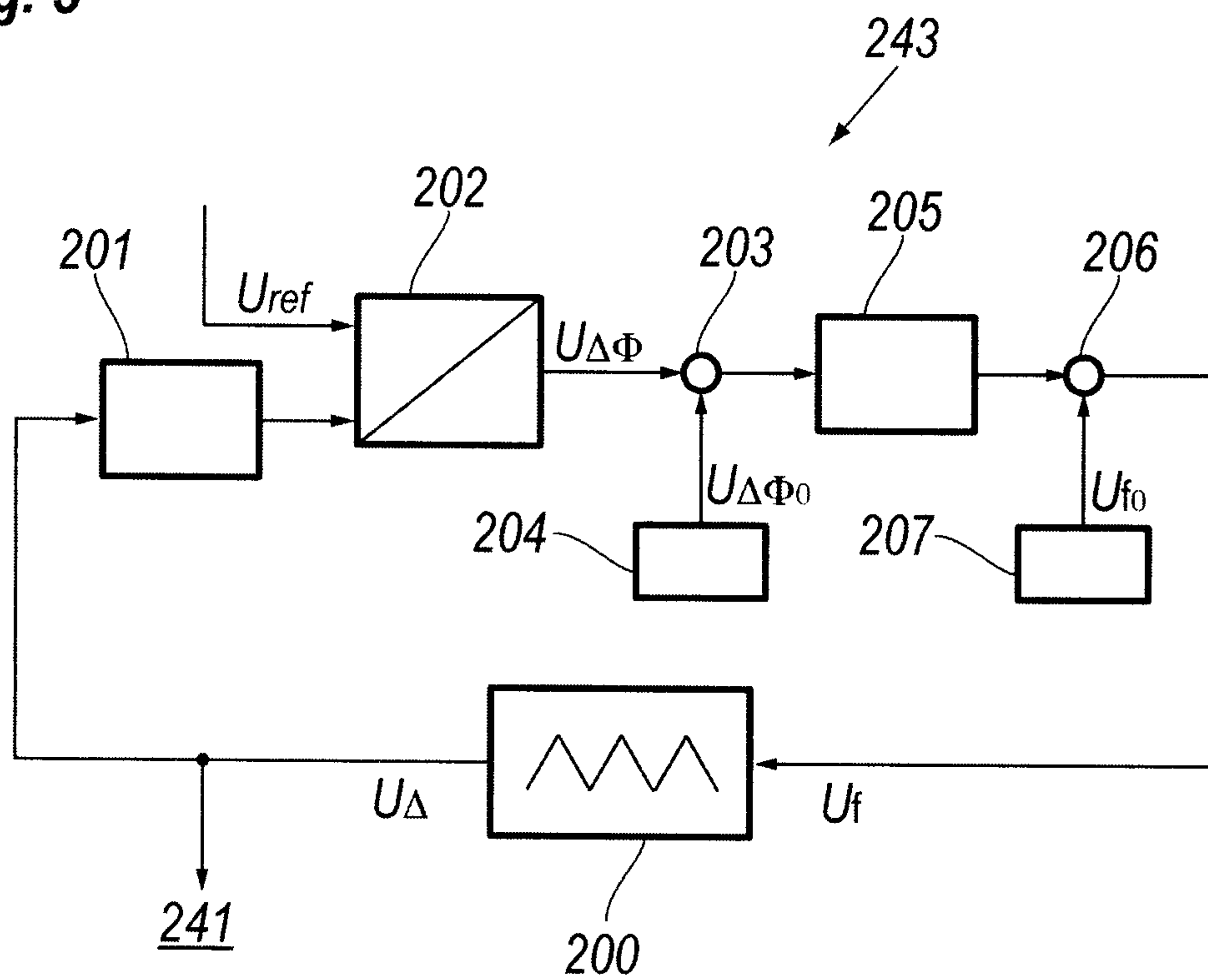

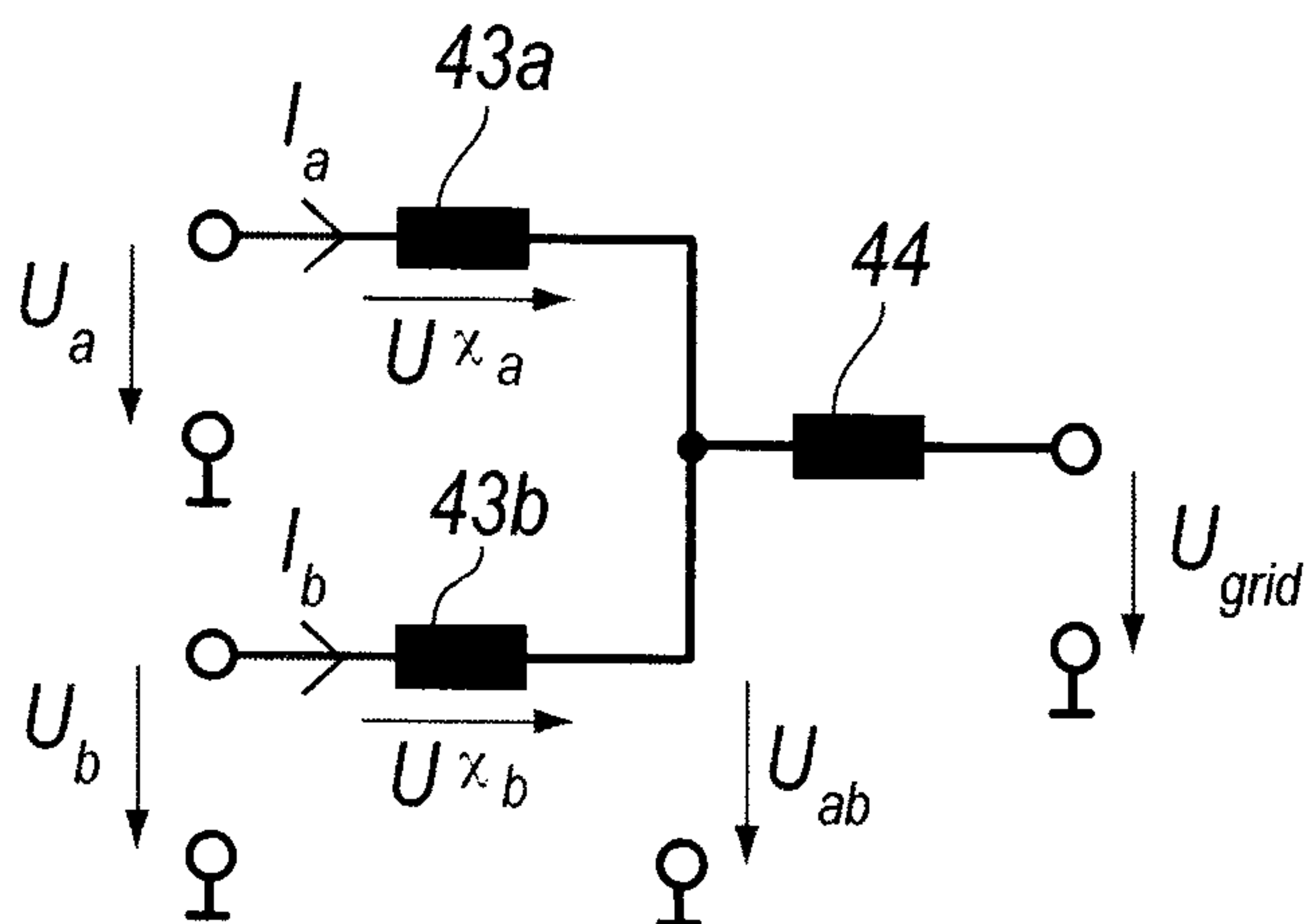
Fig. 6**Fig. 7**

Fig. 1

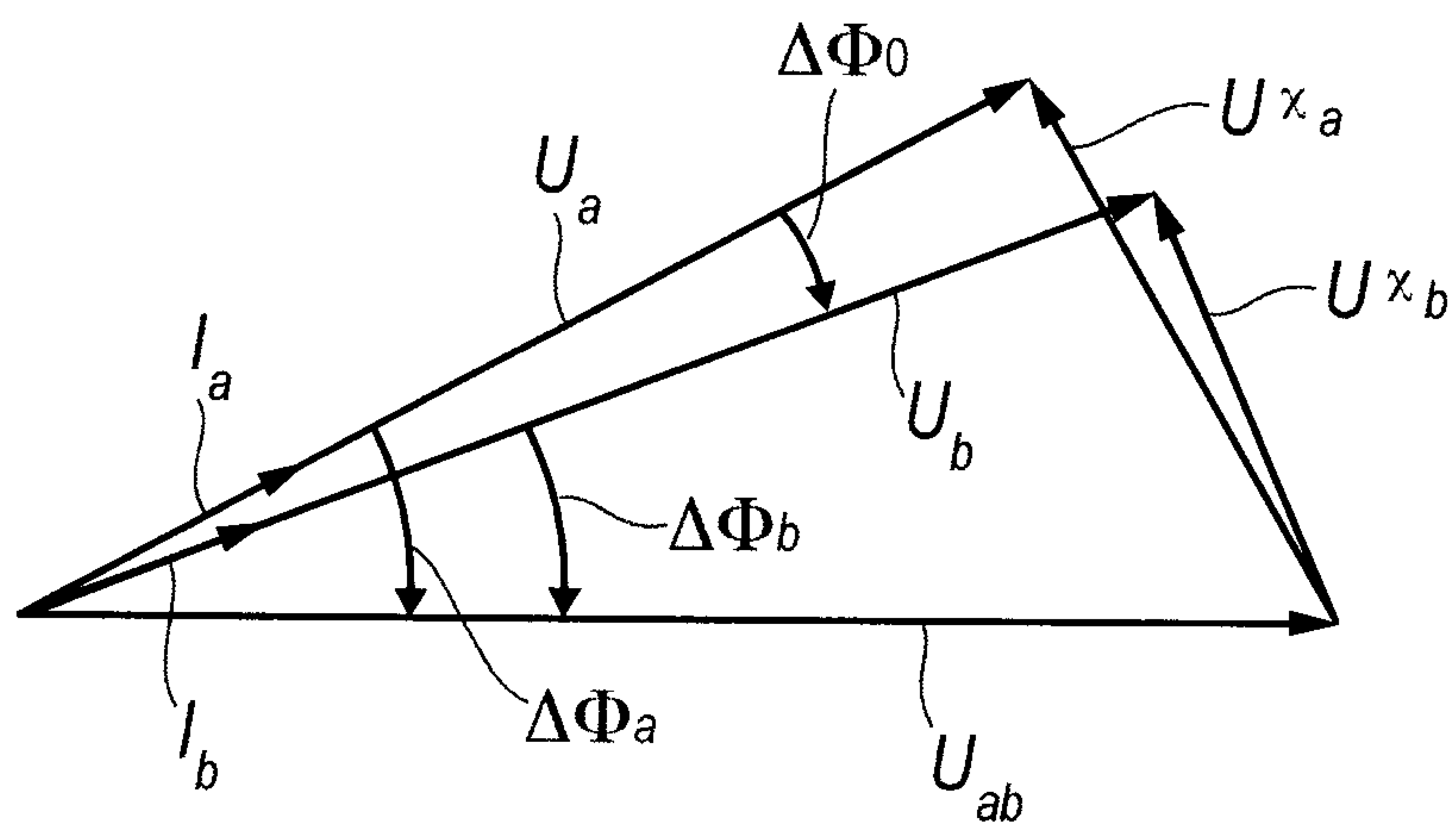