



- (51) International Patent Classification:
H04W 76/02 (2009.01) H04W 16/24 (2009.01)
- (21) International Application Number:
PCT/KR2014/000329
- (22) International Filing Date:
10 January 2014 (10.01.2014)
- (25) Filing Language: English
- (26) Publication Language: English
- (30) Priority Data:
61/751,287 11 January 2013 (11.01.2013) US
- (71) Applicant: LG ELECTRONICS INC. [KR/KR]; 128, Yeoui-daero, Yeongdeungpo-gu, Seoul, 150-721 (KR).
- (72) Inventors: LEE, Young Dae; LG ELECTRONICS INC., Seocho R&D Campus 19 Yangjae-daero 11gil, Seocho-gu, Seoul 137-893 (KR). PARK, Sung Jun; LG ELECTRONICS INC., Seocho R&D Campus 19 Yangjae-daero 11gil, Seocho-gu, Seoul 137-893 (KR). YI, Seung June; LG ELECTRONICS INC., Seocho R&D Campus 19 Yangjae-daero 11gil, Seocho-gu, Seoul 137-893 (KR). JUNG, Sung Hoon; LG ELECTRONICS INC., Seocho R&D Campus 19 Yangjae-daero 11gil, Seocho-gu, Seoul 137-893 (KR).
- (74) Agent: S&IP PATENT & LAW FIRM; (2F. Samheung Yeoksam Bldg., Yeoksam-dong), 5 Teheran-ro 14-gil, Gangnam-gu, Seoul 135-080 (KR).

- (81) Designated States (unless otherwise indicated, for every kind of national protection available): AE, AG, AL, AM, AO, AT, AU, AZ, BA, BB, BG, BH, BN, BR, BW, BY, BZ, CA, CH, CL, CN, CO, CR, CU, CZ, DE, DK, DM, DO, DZ, EC, EE, EG, ES, FI, GB, GD, GE, GH, GM, GT, HN, HR, HU, ID, IL, IN, IR, IS, JP, KE, KG, KN, KP, KR, KZ, LA, LC, LK, LR, LS, LT, LU, LY, MA, MD, ME, MG, MK, MN, MW, MX, MY, MZ, NA, NG, NI, NO, NZ, OM, PA, PE, PG, PH, PL, PT, QA, RO, RS, RU, RW, SA, SC, SD, SE, SG, SK, SL, SM, ST, SV, SY, TH, TJ, TM, TN, TR, TT, TZ, UA, UG, US, UZ, VC, VN, ZA, ZM, ZW.
- (84) Designated States (unless otherwise indicated, for every kind of regional protection available): ARIPO (BW, GH, GM, KE, LR, LS, MW, MZ, NA, RW, SD, SL, SZ, TZ, UG, ZM, ZW), Eurasian (AM, AZ, BY, KG, KZ, RU, TJ, TM), European (AL, AT, BE, BG, CH, CY, CZ, DE, DK, EE, ES, FI, FR, GB, GR, HR, HU, IE, IS, IT, LT, LU, LV, MC, MK, MT, NL, NO, PL, PT, RO, RS, SE, SI, SK, SM, TR), OAPI (BF, BJ, CF, CG, CI, CM, GA, GN, GQ, GW, KM, ML, MR, NE, SN, TD, TG).

Published:
— with international search report (Art. 21(3))

(54) Title: METHOD AND APPARATUS FOR TRANSMITTING INDICATION IN WIRELESS COMMUNICATION SYSTEM

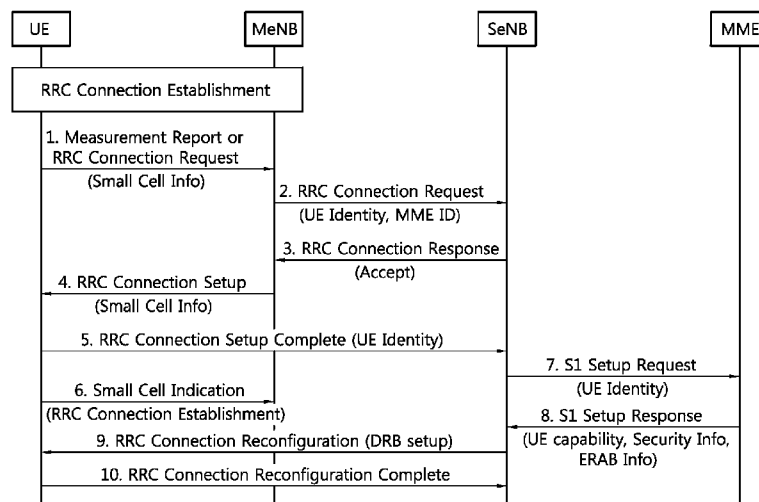

(57) Abstract: A method and apparatus for transmitting an indication in a wireless communication system is provided. A user equipment (UE) transmits an indication to a second node to inform establishment of a connection between a first node and the UE. Alternatively, a method and apparatus for establishing a connection in a wireless communication system is provided.

WO 2014/109603 A1

Description

Title of Invention: METHOD AND APPARATUS FOR TRANSMITTING INDICATION IN WIRELESS COMMUNICATION SYSTEM

Technical Field

[0001] The present invention relates to wireless communications, and more specifically, to a method and apparatus for transmitting an indication in a wireless communication system.

Background Art

[0002] Universal mobile telecommunications system (UMTS) is a 3rd generation (3G) asynchronous mobile communication system operating in wideband code division multiple access (WCDMA) based on European systems, global system for mobile communications (GSM) and general packet radio services (GPRS). A long-term evolution (LTE) of UMTS is under discussion by the 3rd generation partnership project (3GPP) that standardized UMTS.

[0003] The 3GPP LTE is a technology for enabling high-speed packet communications. Many schemes have been proposed for the LTE objective including those that aim to reduce user and provider costs, improve service quality, and expand and improve coverage and system capacity. The 3GPP LTE requires reduced cost per bit, increased service availability, flexible use of a frequency band, a simple structure, an open interface, and adequate power consumption of a terminal as an upper-level requirement.

[0004] Small cells using low power nodes are considered promising to cope with mobile traffic explosion, especially for hotspot deployments in indoor and outdoor scenarios. A low-power node generally means a node whose transmission (Tx) power is lower than macro node and base station (BS) classes, for example a pico and femto eNodeB (eNB) are both applicable. Small cell enhancements for 3GPP LTE will focus on additional functionalities for enhanced performance in hotspot areas for indoor and outdoor using low power nodes.

[0005] Some of activities will focus on achieving an even higher degree of interworking between the macro and low-power layers, including different forms of macro assistance to the low-power layer and dual-layer connectivity. Dual connectivity implies that the device has simultaneous connections to both macro and low-power layers. Macro assistance including dual connectivity may provide several benefits:

[0006] - Enhanced support for mobility - by maintaining the mobility anchor point in the macro layer, it is possible to maintain seamless mobility between macro and low-

power layers, as well as between low-power nodes.

[0007] - Low overhead transmissions from the low-power layer - by transmitting only information required for individual user experience, it is possible to avoid overhead coming from supporting idle-mode mobility within the local-area layer, for example.

[0008] - Energy-efficient load balancing - by turning off the low-power nodes when there is no ongoing data transmission, it is possible to reduce the energy consumption of the low-power layer.

[0009] - Per-link optimization - by being able to select the termination point for uplink and downlink separately, the node selection can be optimized for each link.

[0010] To support the dual connectivity, various changes may be required in current 3GPP LTE radio protocols. For example, a method for splitting radio resource control (RRC) between a macro cell and small cell may be required.

Summary of Invention

Technical Problem

[0011] The present invention provides a method and apparatus for transmitting an indication in a wireless communication system. The present invention provides a method for transmitting an indication to a second node in order to inform connection establishment with a first node. The present invention provides a method for establishing dual RRC connections with both a macro cell and small cell.

Solution to Problem

[0012] In an aspect, a method for transmitting, by a user equipment (UE), an indication in a wireless communication system is provided. The method includes transmitting an indication to a second node to inform establishment of a connection between a first node and the UE.

[0013] The first node may be a secondary eNodeB (SeNB) controlling one or more small cells, and the second node may be a master eNodeB (MeNB) controlling a macro cell.

[0014] The connection between the first node and the UE may be a radio resource control (RRC) connection for a user traffic over data radio bearers (DRBs) of the UE.

[0015] The first node may be an MeNB controlling a macro cell, and the second node may be an SeNB controlling one or more small cells.

[0016] The connection between the first node and the UE may be an RRC connection for mobility of the UE.

[0017] In another aspect, a user equipment (UE) in a wireless communication system is provided. The UE includes a radio frequency (RF) unit for transmitting or receiving a radio signal, and a processor coupled to the RF unit, and configured to transmit an indication to a second node to inform establishment of a connection between a first node and the UE.

- [0018] In another aspect, a method for establishing, by a user equipment (UE), a connection in a wireless communication system is provided. The method includes establishing a first connection with a first eNodeB (eNB), transmitting a connection request for a second connection to the first eNB, receiving a connection setup for the second connection from the first eNB, and transmitting a connection setup complete for the second connection to the second eNB.
- [0019] The first eNB may be a master eNB (MeNB) controlling a macro cell, and the first connection may be a radio resource control (RRC) connection for mobility of the UE.
- [0020] The second eNB may be a secondary eNB (SeNB) controlling one or more small cells, and the second connection may be an RRC connection for a user traffic over data radio bearers (DRBs) of the UE.
- [0021] The connection request for the second connection may include information on a small cell served by the second eNB.
- [0022] The information on the small cell may include at least one of a cell identifier (ID) of the small cell, and a frequency of the small cell.
- [0023] The connection setup for the second connection may include at least one of information on a small cell served by the second eNB, layer configuration used at the small cell, and UE ID used at the small cell.
- [0024] The connection setup complete for the second connection may include an UE ID and mobility management entity (MME) ID to which the first eNB is connected.
- [0025] The method may further include upon receiving the connection setup for the second connection, configuring a signaling radio bearer (SRB) between a small cell served by the second eNB and the UE.
- [0026] The method may further include configuring one or more DRBs with the second eNB by exchanging messages.

Advantageous Effects of Invention

- [0027] Connection establishment with a first node can be informed to a second node.

Brief Description of Drawings

- [0028] FIG. 1 shows LTE system architecture.
- [0029] FIG. 2 shows a control plane of a radio interface protocol of an LTE system.
- [0030] FIG. 3 shows a user plane of a radio interface protocol of an LTE system.
- [0031] FIG. 4 shows an example of a physical channel structure.
- [0032] FIG. 5 shows deployment scenarios of small cells with/without macro coverage.
- [0033] FIG. 6 shows a scenario of dual connectivity.
- [0034] FIG. 7 shows an example of a method for establishing dual RRC connections according to an embodiment of the present invention.
- [0035] FIG. 8 shows an example of a method for transmitting an indication according to an

embodiment of the present invention.

[0036] FIG. 9 shows an example of a method for establishing dual RRC connections according to another embodiment of the present invention.

[0037] FIG. 10 is a block diagram showing wireless communication system to implement an embodiment of the present invention.

Mode for the Invention

[0038] The technology described below can be used in various wireless communication systems such as code division multiple access (CDMA), frequency division multiple access (FDMA), time division multiple access (TDMA), orthogonal frequency division multiple access (OFDMA), single carrier frequency division multiple access (SC-FDMA), etc. The CDMA can be implemented with a radio technology such as universal terrestrial radio access (UTRA) or CDMA-2000. The TDMA can be implemented with a radio technology such as global system for mobile communications (GSM)/general packet radio service (GPRS)/enhanced data rate for GSM evolution (EDGE). The OFDMA can be implemented with a radio technology such as institute of electrical and electronics engineers (IEEE) 802.11 (Wi-Fi), IEEE 802.16 (WiMAX), IEEE 802.20, evolved UTRA (E-UTRA), etc. IEEE 802.16m is evolved from IEEE 802.16e, and provides backward compatibility with a system based on the IEEE 802.16e. The UTRA is a part of a universal mobile telecommunication system (UMTS). 3rd generation partnership project (3GPP) long term evolution (LTE) is a part of an evolved UMTS (E-UMTS) using the E-UTRA. The 3GPP LTE uses the OFDMA in a downlink and uses the SC-FDMA in an uplink. LTE-advanced (LTE-A) is an evolution of the LTE.

[0039] For clarity, the following description will focus on LTE-A. However, technical features of the present invention are not limited thereto.

[0040] FIG. 1 shows LTE system architecture. The communication network is widely deployed to provide a variety of communication services such as voice over internet protocol (VoIP) through IMS and packet data.

[0041] Referring to FIG. 1, the LTE system architecture includes one or more user equipment (UE; 10), an evolved-UMTS terrestrial radio access network (E-UTRAN) and an evolved packet core (EPC). The UE 10 refers to a communication equipment carried by a user. The UE 10 may be fixed or mobile, and may be referred to as another terminology, such as a mobile station (MS), a user terminal (UT), a subscriber station (SS), a wireless device, etc.

[0042] The E-UTRAN includes one or more evolved node-B (eNB) 20, and a plurality of UEs may be located in one cell. The eNB 20 provides an end point of a control plane and a user plane to the UE 10. The eNB 20 is generally a fixed station that com-

municates with the UE 10 and may be referred to as another terminology, such as a base station (BS), a base transceiver system (BTS), an access point, etc. One eNB 20 may be deployed per cell. There are one or more cells within the coverage of the eNB 20. A single cell is configured to have one of bandwidths selected from 1.25, 2.5, 5, 10, and 20 MHz, etc., and provides downlink or uplink transmission services to several UEs. In this case, different cells can be configured to provide different bandwidths.

[0043] Hereinafter, a downlink (DL) denotes communication from the eNB 20 to the UE 10, and an uplink (UL) denotes communication from the UE 10 to the eNB 20. In the DL, a transmitter may be a part of the eNB 20, and a receiver may be a part of the UE 10. In the UL, the transmitter may be a part of the UE 10, and the receiver may be a part of the eNB 20.

[0044] The EPC includes a mobility management entity (MME) which is in charge of control plane functions, and a system architecture evolution (SAE) gateway (S-GW) which is in charge of user plane functions. The MME/S-GW 30 may be positioned at the end of the network and connected to an external network. The MME has UE access information or UE capability information, and such information may be primarily used in UE mobility management. The S-GW is a gateway of which an endpoint is an E-UTRAN. The MME/S-GW 30 provides an end point of a session and mobility management function for the UE 10. The EPC may further include a packet data network (PDN) gateway (PDN-GW). The PDN-GW is a gateway of which an endpoint is a PDN.

[0045] The MME provides various functions including non-access stratum (NAS) signaling to eNBs 20, NAS signaling security, access stratum (AS) security control, Inter core network (CN) node signaling for mobility between 3GPP access networks, idle mode UE reachability (including control and execution of paging retransmission), tracking area list management (for UE in idle and active mode), P-GW and S-GW selection, MME selection for handovers with MME change, serving GPRS support node (SGSN) selection for handovers to 2G or 3G 3GPP access networks, roaming, authentication, bearer management functions including dedicated bearer establishment, support for public warning system (PWS) (which includes earthquake and tsunami warning system (ETWS) and commercial mobile alert system (CMAS)) message transmission. The S-GW host provides assorted functions including per-user based packet filtering (by e.g., deep packet inspection), lawful interception, UE Internet protocol (IP) address allocation, transport level packet marking in the DL, UL and DL service level charging, gating and rate enforcement, DL rate enforcement based on APN-AMBR. For clarity MME/S-GW 30 will be referred to herein simply as a "gateway," but it is understood that this entity includes both the MME and S-GW.

[0046] Interfaces for transmitting user traffic or control traffic may be used. The UE 10 and

the eNB 20 are connected by means of a Uu interface. The eNBs 20 are interconnected by means of an X2 interface. Neighboring eNBs may have a meshed network structure that has the X2 interface. The eNBs 20 are connected to the EPC by means of an S1 interface. The eNBs 20 are connected to the MME by means of an S1-MME interface, and are connected to the S-GW by means of S1-U interface. The S1 interface supports a many-to-many relation between the eNB 20 and the MME/S-GW.

- [0047] The eNB 20 may perform functions of selection for gateway 30, routing toward the gateway 30 during a radio resource control (RRC) activation, scheduling and transmitting of paging messages, scheduling and transmitting of broadcast channel (BCH) information, dynamic allocation of resources to the UEs 10 in both UL and DL, configuration and provisioning of eNB measurements, radio bearer control, radio admission control (RAC), and connection mobility control in LTE_ACTIVE state. In the EPC, and as noted above, gateway 30 may perform functions of paging origination, LTE_IDLE state management, ciphering of the user plane, SAE bearer control, and ciphering and integrity protection of NAS signaling.
- [0048] FIG. 2 shows a control plane of a radio interface protocol of an LTE system. FIG. 3 shows a user plane of a radio interface protocol of an LTE system.
- [0049] Layers of a radio interface protocol between the UE and the E-UTRAN may be classified into a first layer (L1), a second layer (L2), and a third layer (L3) based on the lower three layers of the open system interconnection (OSI) model that is well-known in the communication system. The radio interface protocol between the UE and the E-UTRAN may be horizontally divided into a physical layer, a data link layer, and a network layer, and may be vertically divided into a control plane (C-plane) which is a protocol stack for control signal transmission and a user plane (U-plane) which is a protocol stack for data information transmission. The layers of the radio interface protocol exist in pairs at the UE and the E-UTRAN, and are in charge of data transmission of the Uu interface.
- [0050] A physical (PHY) layer belongs to the L1. The PHY layer provides a higher layer with an information transfer service through a physical channel. The PHY layer is connected to a medium access control (MAC) layer, which is a higher layer of the PHY layer, through a transport channel. A physical channel is mapped to the transport channel. Data is transferred between the MAC layer and the PHY layer through the transport channel. Between different PHY layers, i.e., a PHY layer of a transmitter and a PHY layer of a receiver, data is transferred through the physical channel using radio resources. The physical channel is modulated using an orthogonal frequency division multiplexing (OFDM) scheme, and utilizes time and frequency as a radio resource.
- [0051] The PHY layer uses several physical control channels. A physical downlink control channel (PDCCH) reports to a UE about resource allocation of a paging channel (PCH)

and a downlink shared channel (DL-SCH), and hybrid automatic repeat request (HARQ) information related to the DL-SCH. The PDCCH may carry a UL grant for reporting to the UE about resource allocation of UL transmission. A physical control format indicator channel (PCFICH) reports the number of OFDM symbols used for PDCCHs to the UE, and is transmitted in every subframe. A physical hybrid ARQ indicator channel (PHICH) carries an HARQ acknowledgement (ACK)/non-acknowledgement (NACK) signal in response to UL transmission. A physical uplink control channel (PUCCH) carries UL control information such as HARQ ACK/NACK for DL transmission, scheduling request, and CQI. A physical uplink shared channel (PUSCH) carries a UL-uplink shared channel (SCH).

[0052] FIG. 4 shows an example of a physical channel structure.

[0053] A physical channel consists of a plurality of subframes in time domain and a plurality of subcarriers in frequency domain. One subframe consists of a plurality of symbols in the time domain. One subframe consists of a plurality of resource blocks (RBs). One RB consists of a plurality of symbols and a plurality of subcarriers. In addition, each subframe may use specific subcarriers of specific symbols of a corresponding subframe for a PDCCH. For example, a first symbol of the subframe may be used for the PDCCH. The PDCCH carries dynamic allocated resources, such as a physical resource block (PRB) and modulation and coding scheme (MCS). A transmission time interval (TTI) which is a unit time for data transmission may be equal to a length of one subframe. The length of one subframe may be 1 ms.

[0054] The transport channel is classified into a common transport channel and a dedicated transport channel according to whether the channel is shared or not. A DL transport channel for transmitting data from the network to the UE includes a broadcast channel (BCH) for transmitting system information, a paging channel (PCH) for transmitting a paging message, a DL-SCH for transmitting user traffic or control signals, etc. The DL-SCH supports HARQ, dynamic link adaptation by varying the modulation, coding and transmit power, and both dynamic and semi-static resource allocation. The DL-SCH also may enable broadcast in the entire cell and the use of beamforming. The system information carries one or more system information blocks. All system information blocks may be transmitted with the same periodicity. Traffic or control signals of a multimedia broadcast/multicast service (MBMS) may be transmitted through the DL-SCH or a multicast channel (MCH).

[0055] A UL transport channel for transmitting data from the UE to the network includes a random access channel (RACH) for transmitting an initial control message, a UL-SCH for transmitting user traffic or control signals, etc. The UL-SCH supports HARQ and dynamic link adaptation by varying the transmit power and potentially modulation and coding. The UL-SCH also may enable the use of beamforming. The RACH is normally

used for initial access to a cell.

- [0056] A MAC layer belongs to the L2. The MAC layer provides services to a radio link control (RLC) layer, which is a higher layer of the MAC layer, via a logical channel. The MAC layer provides a function of mapping multiple logical channels to multiple transport channels. The MAC layer also provides a function of logical channel multiplexing by mapping multiple logical channels to a single transport channel. A MAC sublayer provides data transfer services on logical channels.
- [0057] The logical channels are classified into control channels for transferring control plane information and traffic channels for transferring user plane information, according to a type of transmitted information. That is, a set of logical channel types is defined for different data transfer services offered by the MAC layer. The logical channels are located above the transport channel, and are mapped to the transport channels.
- [0058] The control channels are used for transfer of control plane information only. The control channels provided by the MAC layer include a broadcast control channel (BCCH), a paging control channel (PCCH), a common control channel (CCCH), a multicast control channel (MCCH) and a dedicated control channel (DCCH). The BCCH is a downlink channel for broadcasting system control information. The PCCH is a downlink channel that transfers paging information and is used when the network does not know the location cell of a UE. The CCCH is used by UEs having no RRC connection with the network. The MCCH is a point-to-multipoint downlink channel used for transmitting MBMS control information from the network to a UE. The DCCH is a point-to-point bi-directional channel used by UEs having an RRC connection that transmits dedicated control information between a UE and the network.
- [0059] Traffic channels are used for the transfer of user plane information only. The traffic channels provided by the MAC layer include a dedicated traffic channel (DTCH) and a multicast traffic channel (MTCH). The DTCH is a point-to-point channel, dedicated to one UE for the transfer of user information and can exist in both uplink and downlink. The MTCH is a point-to-multipoint downlink channel for transmitting traffic data from the network to the UE.
- [0060] Uplink connections between logical channels and transport channels include the DCCH that can be mapped to the UL-SCH, the DTCH that can be mapped to the UL-SCH and the CCCH that can be mapped to the UL-SCH. Downlink connections between logical channels and transport channels include the BCCH that can be mapped to the BCH or DL-SCH, the PCCH that can be mapped to the PCH, the DCCH that can be mapped to the DL-SCH, and the DTCH that can be mapped to the DL-SCH, the MCCH that can be mapped to the MCH, and the MTCH that can be mapped to the MCH.
- [0061] An RLC layer belongs to the L2. The RLC layer provides a function of adjusting a

size of data, so as to be suitable for a lower layer to transmit the data, by concatenating and segmenting the data received from an upper layer in a radio section. In addition, to ensure a variety of quality of service (QoS) required by a radio bearer (RB), the RLC layer provides three operation modes, i.e., a transparent mode (TM), an unacknowledged mode (UM), and an acknowledged mode (AM). The AM RLC provides a retransmission function through an automatic repeat request (ARQ) for reliable data transmission. Meanwhile, a function of the RLC layer may be implemented with a functional block inside the MAC layer. In this case, the RLC layer may not exist.

[0062] A packet data convergence protocol (PDCP) layer belongs to the L2. The PDCP layer provides a function of header compression function that reduces unnecessary control information such that data being transmitted by employing IP packets, such as IPv4 or IPv6, can be efficiently transmitted over a radio interface that has a relatively small bandwidth. The header compression increases transmission efficiency in the radio section by transmitting only necessary information in a header of the data. In addition, the PDCP layer provides a function of security. The function of security includes ciphering which prevents inspection of third parties, and integrity protection which prevents data manipulation of third parties.

[0063] A radio resource control (RRC) layer belongs to the L3. The RRC layer is located at the lowest portion of the L3, and is only defined in the control plane. The RRC layer takes a role of controlling a radio resource between the UE and the network. For this, the UE and the network exchange an RRC message through the RRC layer. The RRC layer controls logical channels, transport channels, and physical channels in relation to the configuration, reconfiguration, and release of RBs. An RB is a logical path provided by the L1 and L2 for data delivery between the UE and the network. That is, the RB signifies a service provided the L2 for data transmission between the UE and E-UTRAN. The configuration of the RB implies a process for specifying a radio protocol layer and channel properties to provide a particular service and for determining respective detailed parameters and operations. The RB is classified into two types, i.e., a signaling RB (SRB) and a data RB (DRB). The SRB is used as a path for transmitting an RRC message in the control plane. The DRB is used as a path for transmitting user data in the user plane.

[0064] Referring to FIG. 2, the RLC and MAC layers (terminated in the eNB on the network side) may perform functions such as scheduling, automatic repeat request (ARQ), and hybrid automatic repeat request (HARQ). The RRC layer (terminated in the eNB on the network side) may perform functions such as broadcasting, paging, RRC connection management, RB control, mobility functions, and UE measurement reporting and controlling. The NAS control protocol (terminated in the MME of gateway on the network side) may perform functions such as a SAE bearer

management, authentication, LTE_IDLE mobility handling, paging origination in LTE_IDLE, and security control for the signaling between the gateway and UE.

- [0065] Referring to FIG. 3, the RLC and MAC layers (terminated in the eNB on the network side) may perform the same functions for the control plane. The PDCP layer (terminated in the eNB on the network side) may perform the user plane functions such as header compression, integrity protection, and ciphering.
- [0066] An RRC state indicates whether an RRC layer of the UE is logically connected to an RRC layer of the E-UTRAN. The RRC state may be divided into two different states such as an RRC connected state and an RRC idle state. When an RRC connection is established between the RRC layer of the UE and the RRC layer of the E-UTRAN, the UE is in RRC_CONNECTED, and otherwise the UE is in RRC_IDLE. Since the UE in RRC_CONNECTED has the RRC connection established with the E-UTRAN, the E-UTRAN may recognize the existence of the UE in RRC_CONNECTED and may effectively control the UE. Meanwhile, the UE in RRC_IDLE may not be recognized by the E-UTRAN, and a CN manages the UE in unit of a TA which is a larger area than a cell. That is, only the existence of the UE in RRC_IDLE is recognized in unit of a large area, and the UE must transition to RRC_CONNECTED to receive a typical mobile communication service such as voice or data communication.
- [0067] In RRC_IDLE state, the UE may receive broadcasts of system information and paging information while the UE specifies a discontinuous reception (DRX) configured by NAS, and the UE has been allocated an identification (ID) which uniquely identifies the UE in a tracking area and may perform public land mobile network (PLMN) selection and cell re-selection. Also, in RRC_IDLE state, no RRC context is stored in the eNB.
- [0068] In RRC_CONNECTED state, the UE has an E-UTRAN RRC connection and a context in the E-UTRAN, such that transmitting and/or receiving data to/from the eNB becomes possible. Also, the UE can report channel quality information and feedback information to the eNB. In RRC_CONNECTED state, the E-UTRAN knows the cell to which the UE belongs. Therefore, the network can transmit and/or receive data to/from UE, the network can control mobility (handover and inter-radio access technologies (RAT) cell change order to GSM EDGE radio access network (GERAN) with network assisted cell change (NACC)) of the UE, and the network can perform cell measurements for a neighboring cell.
- [0069] In RRC_IDLE state, the UE specifies the paging DRX cycle. Specifically, the UE monitors a paging signal at a specific paging occasion of every UE specific paging DRX cycle. The paging occasion is a time interval during which a paging signal is transmitted. The UE has its own paging occasion.
- [0070] A paging message is transmitted over all cells belonging to the same tracking area. If

the UE moves from one TA to another TA, the UE will send a tracking area update (TAU) message to the network to update its location.

- [0071] When the user initially powers on the UE, the UE first searches for a proper cell and then remains in RRC_IDLE in the cell. When there is a need to establish an RRC connection, the UE which remains in RRC_IDLE establishes the RRC connection with the RRC of the E-UTRAN through an RRC connection procedure and then may transition to RRC_CONNECTED. The UE which remains in RRC_IDLE may need to establish the RRC connection with the E-UTRAN when uplink data transmission is necessary due to a user's call attempt or the like or when there is a need to transmit a response message upon receiving a paging message from the E-UTRAN.
- [0072] It is known that different cause values may be mapped to the signature sequence used to transmit messages between a UE and eNB and that either channel quality indicator (CQI) or path loss and cause or message size are candidates for inclusion in the initial preamble.
- [0073] When a UE wishes to access the network and determines a message to be transmitted, the message may be linked to a purpose and a cause value may be determined. The size of the ideal message may be also be determined by identifying all optional information and different alternative sizes, such as by removing optional information, or an alternative scheduling request message may be used.
- [0074] The UE acquires necessary information for the transmission of the preamble, UL interference, pilot transmit power and required signal-to-noise ratio (SNR) for the preamble detection at the receiver or combinations thereof. This information must allow the calculation of the initial transmit power of the preamble. It is beneficial to transmit the UL message in the vicinity of the preamble from a frequency point of view in order to ensure that the same channel is used for the transmission of the message.
- [0075] The UE should take into account the UL interference and the UL path loss in order to ensure that the network receives the preamble with a minimum SNR. The UL interference can be determined only in the eNB, and therefore, must be broadcast by the eNB and received by the UE prior to the transmission of the preamble. The UL path loss can be considered to be similar to the DL path loss and can be estimated by the UE from the received RX signal strength when the transmit power of some pilot sequence of the cell is known to the UE.
- [0076] The required UL SNR for the detection of the preamble would typically depend on the eNB configuration, such as a number of Rx antennas and receiver performance. There may be advantages to transmit the rather static transmit power of the pilot and the necessary UL SNR separately from the varying UL interference and possibly the power offset required between the preamble and the message.

- [0077] The initial transmission power of the preamble can be roughly calculated according to the following formula:
- [0078] $\text{Transmit power} = \text{TransmitPilot} - \text{RxPilot} + \text{ULInterference} + \text{Offset} + \text{SNRRequired}$
- [0079] Therefore, any combination of SNRRequired, ULInterference, TransmitPilot and Offset can be broadcast. In principle, only one value must be broadcast. This is essentially in current UMTS systems, although the UL interference in 3GPP LTE will mainly be neighboring cell interference that is probably more constant than in UMTS system.
- [0080] The UE determines the initial UL transmit power for the transmission of the preamble as explained above. The receiver in the eNB is able to estimate the absolute received power as well as the relative received power compared to the interference in the cell. The eNB will consider a preamble detected if the received signal power compared to the interference is above an eNB known threshold.
- [0081] The UE performs power ramping in order to ensure that a UE can be detected even if the initially estimated transmission power of the preamble is not adequate. Another preamble will most likely be transmitted if no ACK or NACK is received by the UE before the next random access attempt. The transmit power of the preamble can be increased, and/or the preamble can be transmitted on a different UL frequency in order to increase the probability of detection. Therefore, the actual transmit power of the preamble that will be detected does not necessarily correspond to the initial transmit power of the preamble as initially calculated by the UE.
- [0082] The UE must determine the possible UL transport format. The transport format, which may include MCS and a number of resource blocks that should be used by the UE, depends mainly on two parameters, specifically the SNR at the eNB and the required size of the message to be transmitted.
- [0083] In practice, a maximum UE message size, or payload, and a required minimum SNR correspond to each transport format. In UMTS, the UE determines before the transmission of the preamble whether a transport format can be chosen for the transmission according to the estimated initial preamble transmit power, the required offset between preamble and the transport block, the maximum allowed or available UE transmit power, a fixed offset and additional margin. The preamble in UMTS need not contain any information regarding the transport format selected by the EU since the network does not need to reserve time and frequency resources and, therefore, the transport format is indicated together with the transmitted message.
- [0084] The eNB must be aware of the size of the message that the UE intends to transmit and the SNR achievable by the UE in order to select the correct transport format upon reception of the preamble and then reserve the necessary time and frequency resources. Therefore, the eNB cannot estimate the SNR achievable by the EU according to the

received preamble because the UE transmit power compared to the maximum allowed or possible UE transmit power is not known to the eNB, given that the UE will most likely consider the measured path loss in the DL or some equivalent measure for the determination of the initial preamble transmission power.

[0085] The eNB could calculate a difference between the path loss estimated in the DL compared and the path loss of the UL. However, this calculation is not possible if power ramping is used and the UE transmit power for the preamble does not correspond to the initially calculated UE transmit power. Furthermore, the precision of the actual UE transmit power and the transmit power at which the UE is intended to transmit is very low. Therefore, it has been proposed to code the path loss or CQI estimation of the downlink and the message size or the cause value in the UL in the signature.

[0086] FIG. 5 shows deployment scenarios of small cells with/without macro coverage. It may be referred to Section 6.1 of 3GPP TR 36.932 V12.0.0 (2012-12). Small cell enhancement should target both with and without macro coverage, both outdoor and indoor small cell deployments and both ideal and non-ideal backhaul. Both sparse and dense small cell deployments should be considered.

[0087] Referring to FIG. 5, small cell enhancement should target the deployment scenario in which small cell nodes are deployed under the coverage of one or more than one overlaid E-UTRAN macro-cell layer(s) in order to boost the capacity of already deployed cellular network. Two scenarios where the UE is in coverage of both the macro cell and the small cell simultaneously, and where the UE is not in coverage of both the macro cell and the small cell simultaneously can be considered. Also, the deployment scenario where small cell nodes are not deployed under the coverage of one or more overlaid E-UTRAN macro-cell layer(s) may be considered.

[0088] Small cell enhancement should target both outdoor and indoor small cell deployments. The small cell nodes could be deployed indoors or outdoors, and in either case could provide service to indoor or outdoor UEs.

[0089] Dual connectivity for small cell enhancement has been studied. Dual connectivity may imply:

[0090] - Control and data separation where, for instance, the control signaling for mobility is provided via the macro layer at the same time as high-speed data connectivity is provided via the low-power layer.

[0091] - A separation between downlink and uplink, where downlink and uplink connectivity is provided via different layers.

[0092] - Diversity for control signaling, where radio resource control (RRC) signaling may be provided via multiple links, further enhancing mobility performance.

[0093] FIG. 6 shows a scenario of dual connectivity.

- [0094] Referring to FIG. 6, the UE has an RRC connection with the master eNB (hereinafter, MeNB). In dual connectivity, the MeNB controls the macro cell, and is the eNB which terminates at least S1-MME and therefore act as mobility anchor towards the CN. Also, the UE has a radio link with the secondary eNB (hereinafter, SeNB). In dual connectivity, the SeNB controls one or more small cells, and is the eNB providing additional radio resources for the UE, which is not the MeNB. Accordingly, the UE may receive control signaling from the MeNB, and may receive data from the SeNB. The MeNB and SeNB has a network interface between thereof, and therefore, information may be exchanged between the MeNB and SeNB.
- [0095] Hereinafter, a method for splitting RRC between a macro cell and small cell according to an embodiment of the present invention is described. That is, a method for establishing dual RRC connections with both the macro cell and small cell according to an embodiment of the present invention is described. According to an embodiment of the present invention, the UE establishes a first RRC connection with the MeNB (first eNB controlling macro cell) for mobility of the UE and a second RRC connection with the SeNB (second eNB controlling one or more small cells) for user traffic over DRBs. The UE may configure one or more DRBs with the second eNB by exchanging messages over the second RRC connection. The UE may change the first RRC connection from the first eNB to a third eNB by receiving a handover command from the first eNB. The UE may receive a second RRC connection setup command from the first eNB before establishing the second RRC connection with the second eNB. The UE may indicate establishment of the second RRC connection to the first eNB after establishing the second RRC connection with the second eNB. The UE may change the second RRC connection from the second eNB to a fourth eNB by receiving a handover command from the first eNB.
- [0096] FIG. 7 shows an example of a method for establishing dual RRC connections according to an embodiment of the present invention. It is assumed that the UE has an RRC connection with a cell of the MeNB (e.g., PCell).
- [0097] 1. If the UE identifies a small cell for an RRC connection, the UE transmits the measurement report or the RRC connection request message to the MeNB. The measurement report or the RRC connection request message may include information on the identified small cell such as cell identifier (ID) and frequency of the small cell.
- [0098] 2. If the MeNB receives the measurement report or the RRC connection request message identifying the small cell, the MeNB may decide to establish the RRC connection between a cell of the SeNB and the UE.
- [0099] If the MeNB decides to establish the RRC connection between the cell of the SeNB and the UE, the MeNB transmits the RRC connection request message to the SeNB in order to make an RRC connection with the small cell of the SeNB. The RRC

connection request message may include a UE identity, and possibly UE capability and security information (such as security key and security parameter that will be used by the small cell of the SeNB for the UE).

- [0100] If the MeNB decides not to establish the RRC connection between the cell of the SeNB and the UE, the MeNB transmits the RRC connection reject message to the UE. The RRC connection reject message may include the cell ID of the small cell and a reject cause.
- [0101] 3. Upon receiving the RRC connection request message from the MeNB, if the SeNB accepts the RRC connection request for the UE, the SeNB transmits the RRC connection response message indicating acceptance of the RRC connection establishment. Otherwise, the SeNB transmits the RRC connection response message indicating rejection of the RRC connection establishment.
- [0102] 4. If the MeNB receives the RRC connection response message indicating acceptance of the RRC connection establishment from the SeNB, the MeNB transmits the RRC connection setup message to the UE. The RRC connection setup message may include information on the small cell, layer 1/2/3 configuration used at the small cell of the SeNB, and UE identity used at the small cell of the SeNB.
- [0103] If the MeNB receives the RRC connection response indicating rejection of the RRC connection establishment from the SeNB, the MeNB transmits the RRC connection reject message including the cell ID of the small cell and the reject cause.
- [0104] Upon receiving the RRC connection setup message from the MeNB for the RRC connection with the small cell, the UE configures an SRB between the small cell of the SeNB and the UE.
- [0105] 5. The UE transmits the RRC connection setup complete message to the SeNB (or the MeNB). The RRC connection setup complete message may include the UE identity and the MME ID which the MeNB is connected to for the UE.
- [0106] 6. Upon establishing the RRC connection between the small cell of the SeNB and the UE, the UE transmits the small cell indication to the MeNB in order to inform the MeNB about RRC connection establishment between the small cell of the SeNB and the UE.
- [0107] 7. Upon establishing the RRC connection between the small cell of the SeNB and the UE, the SeNB establishes an S1 connection with the MME that may be indicated in the RRC connection setup complete message from the UE or the RRC connection request message from the MeNB, by transmitting S1 setup request to the MME.
- [0108] 8. Upon receiving the S1 setup request message, the MME may inform the SeNB of UE capability information and security information such as security key and security parameter used for secure communication between the SeNB and the UE. The MME may also inform the SeNB of information on one or more E-UTRAN radio access

bearers (ERABs) to be established for the UE.

- [0109] 9. Based on information received from the MeNB and/or the MME, the SeNB transmits the RRC connection reconfiguration message to the UE. The RRC connection reconfiguration message may include radio configurations and DRB configurations.
- [0110] 10. Upon receiving the RRC connection reconfiguration message, the UE establishes one or more DRBs and then transmits the RRC connection reconfiguration complete message to the SeNB.
- [0111] FIG. 8 shows an example of a method for transmitting an indication according to an embodiment of the present invention.
- [0112] In step S100, the UE transmits an indication to a second node to inform establishment of a connection between a first node and the UE. The first node may be the SeNB controlling one or more small cells, and the second node may be the MeNB controlling a macro cell. At this time, the connection between the first node and the UE may be an RRC connection for a user traffic over DRBs of the UE. Alternatively, the first node may be the MeNB controlling a macro cell, and the second node may be the SeNB controlling one or more small cells. At this time, the connection between the first node and the UE may be an RRC connection for mobility of the UE.
- [0113] FIG. 9 shows an example of a method for establishing dual RRC connections according to another embodiment of the present invention.
- [0114] In step S200, the UE establishes a first connection with a first eNB.
- [0115] In step S210, the UE transmits a connection request for a second connection to the first eNB. The connection request for the second connection may include information on a small cell served by the second eNB. The information on the small cell includes at least one of a cell ID of the small cell, and a frequency of the small cell.
- [0116] In step S220, the UE receives a connection setup for the second connection from the first eNB. The connection setup for the second connection may include at least one of information on a small cell served by the second eNB, layer configuration used at the small cell, and UE ID used at the small cell. Upon receiving the connection setup for the second connection, the UE may configure an SRB between the small cell served by the second eNB and the UE.
- [0117] In step S230, the UE transmits a connection setup complete for the second connection to the second eNB. The connection setup complete for the second connection may include a UE ID and mobility management entity (MME) ID to which the first eNB is connected.
- [0118] In the description above, the first eNB may be the MeNB controlling a macro cell, and the first connection may be an RRC connection for mobility of the UE. The second eNB may be the SeNB controlling one or more small cells, and the second connection

may be an RRC connection for a user traffic over DRBs of the UE. The UE may configure one or more DRBs with the second eNB by exchanging messages.

[0119] FIG. 10 is a block diagram showing wireless communication system to implement an embodiment of the present invention.

[0120] An eNB 800 may include a processor 810, a memory 820 and a radio frequency (RF) unit 830. The processor 810 may be configured to implement proposed functions, procedures and/or methods described in this description. Layers of the radio interface protocol may be implemented in the processor 810. The memory 820 is operatively coupled with the processor 810 and stores a variety of information to operate the processor 810. The RF unit 830 is operatively coupled with the processor 810, and transmits and/or receives a radio signal.

[0121] A UE 900 may include a processor 910, a memory 920 and a RF unit 930. The processor 910 may be configured to implement proposed functions, procedures and/or methods described in this description. Layers of the radio interface protocol may be implemented in the processor 910. The memory 920 is operatively coupled with the processor 910 and stores a variety of information to operate the processor 910. The RF unit 930 is operatively coupled with the processor 910, and transmits and/or receives a radio signal.

[0122] The processors 810, 910 may include application-specific integrated circuit (ASIC), other chipset, logic circuit and/or data processing device. The memories 820, 920 may include read-only memory (ROM), random access memory (RAM), flash memory, memory card, storage medium and/or other storage device. The RF units 830, 930 may include baseband circuitry to process radio frequency signals. When the embodiments are implemented in software, the techniques described herein can be implemented with modules (e.g., procedures, functions, and so on) that perform the functions described herein. The modules can be stored in memories 820, 920 and executed by processors 810, 910. The memories 820, 920 can be implemented within the processors 810, 910 or external to the processors 810, 910 in which case those can be communicatively coupled to the processors 810, 910 via various means as is known in the art.

[0123] In view of the exemplary systems described herein, methodologies that may be implemented in accordance with the disclosed subject matter have been described with reference to several flow diagrams. While for purposed of simplicity, the methodologies are shown and described as a series of steps or blocks, it is to be understood and appreciated that the claimed subject matter is not limited by the order of the steps or blocks, as some steps may occur in different orders or concurrently with other steps from what is depicted and described herein. Moreover, one skilled in the art would understand that the steps illustrated in the flow diagram are not exclusive and other steps may be included or one or more of the steps in the example flow diagram

may be deleted without affecting the scope and spirit of the present disclosure.

Claims

- [Claim 1] A method for transmitting, by a user equipment (UE), an indication in a wireless communication system, the method comprising:
transmitting an indication to a second node to inform establishment of a connection between a first node and the UE.
- [Claim 2] The method of claim 1, wherein the first node is a secondary eNodeB (SeNB) controlling one or more small cells, and
wherein the second node is a master eNodeB (MeNB) controlling a macro cell.
- [Claim 3] The method of claim 2, wherein the connection between the first node and the UE is a radio resource control (RRC) connection for a user traffic over data radio bearers (DRBs) of the UE.
- [Claim 4] The method of claim 1, wherein the first node is an MeNB controlling a macro cell, and
wherein the second node is an SeNB controlling one or more small cells.
- [Claim 5] The method of claim 4, wherein the connection between the first node and the UE is an RRC connection for mobility of the UE.
- [Claim 6] A user equipment (UE) in a wireless communication system, the UE comprising:
a radio frequency (RF) unit for transmitting or receiving a radio signal;
and
a processor coupled to the RF unit, and configured to:
transmit an indication to a second node to inform establishment of a connection between a first node and the UE.
- [Claim 7] A method for establishing, by a user equipment (UE), a connection in a wireless communication system, the method comprising:
establishing a first connection with a first eNodeB (eNB);
transmitting a connection request for a second connection to the first eNB;
receiving a connection setup for the second connection from the first eNB; and
transmitting a connection setup complete for the second connection to the second eNB.
- [Claim 8] The method of claim 7, wherein the first eNB is a master eNB (MeNB) controlling a macro cell, and
wherein the first connection is a radio resource control (RRC)

- connection for mobility of the UE.
- [Claim 9] The method of claim 7, wherein the second eNB is a secondary eNB (SeNB) controlling one or more small cells, and wherein the second connection is an RRC connection for a user traffic over data radio bearers (DRBs) of the UE.
- [Claim 10] The method of claim 7, wherein the connection request for the second connection includes information on a small cell served by the second eNB.
- [Claim 11] The method of claim 10, wherein the information on the small cell includes at least one of a cell identifier (ID) of the small cell, and a frequency of the small cell.
- [Claim 12] The method of claim 7, wherein the connection setup for the second connection includes at least one of information on a small cell served by the second eNB, layer configuration used at the small cell, and UE ID used at the small cell.
- [Claim 13] The method of claim 7, wherein the connection setup complete for the second connection includes an UE ID and mobility management entity (MME) ID to which the first eNB is connected.
- [Claim 14] The method of claim 7, further comprising:
upon receiving the connection setup for the second connection, configuring a signaling radio bearer (SRB) between a small cell served by the second eNB and the UE.
- [Claim 15] The method of claim 7, further comprising:
configuring one or more DRBs with the second eNB by exchanging messages.

[Fig. 1]

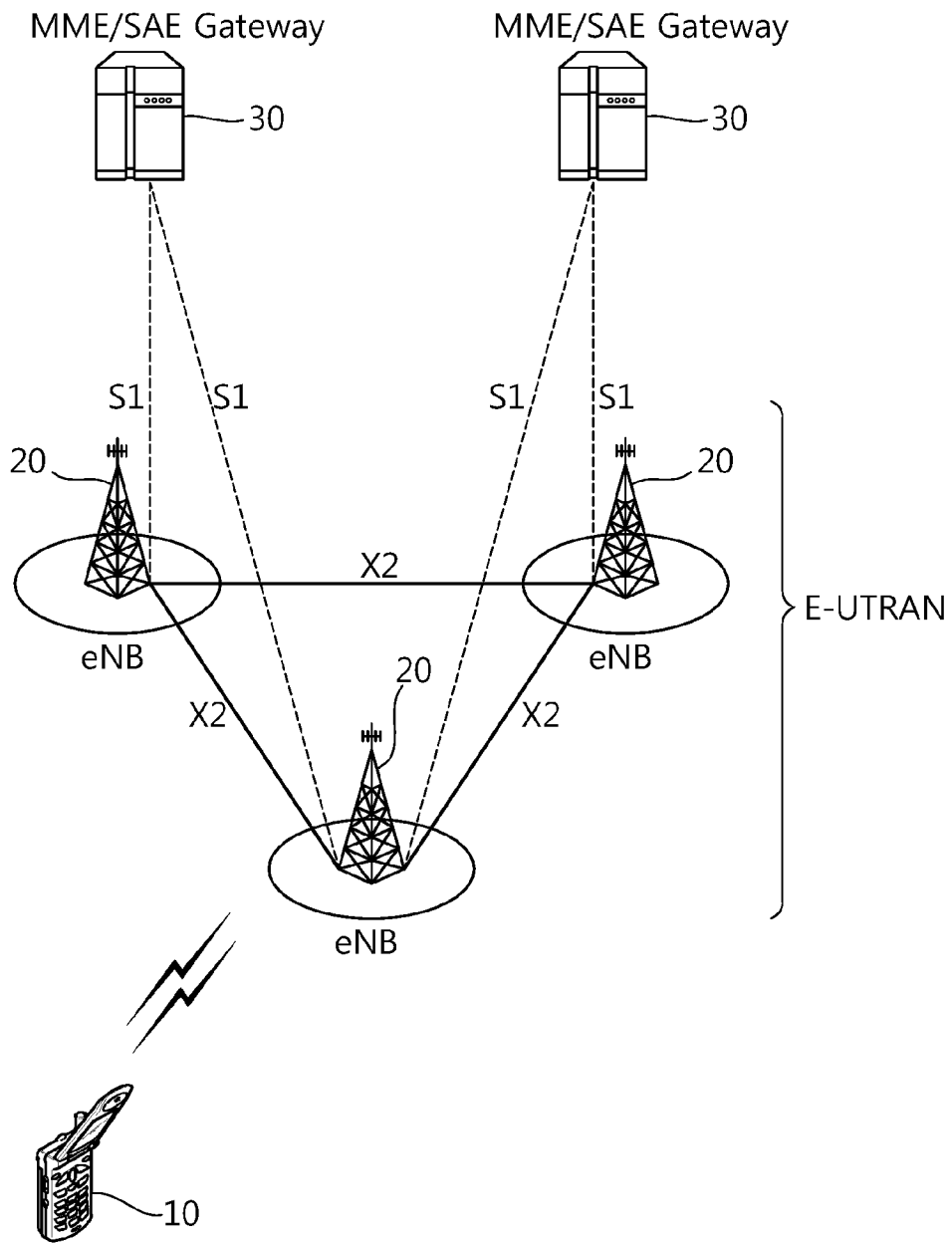

[Fig. 2]

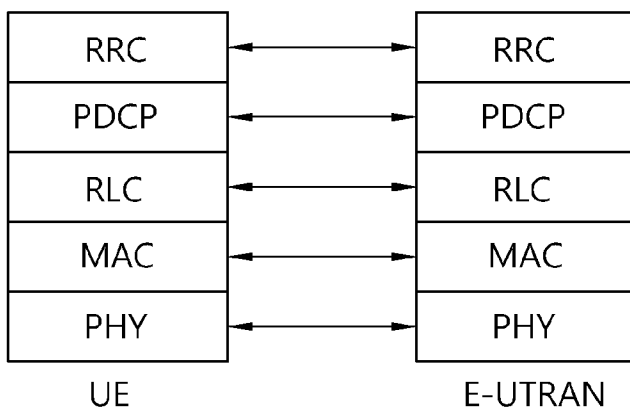

[Fig. 3]

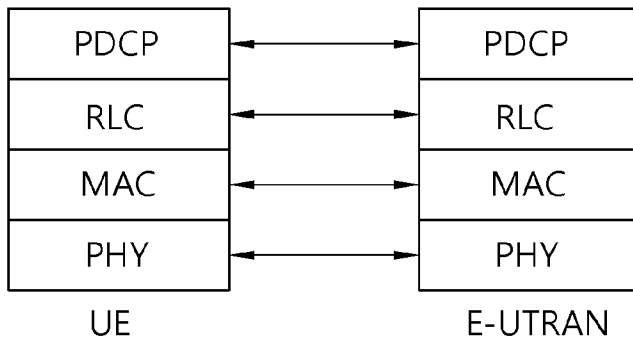

[Fig. 4]

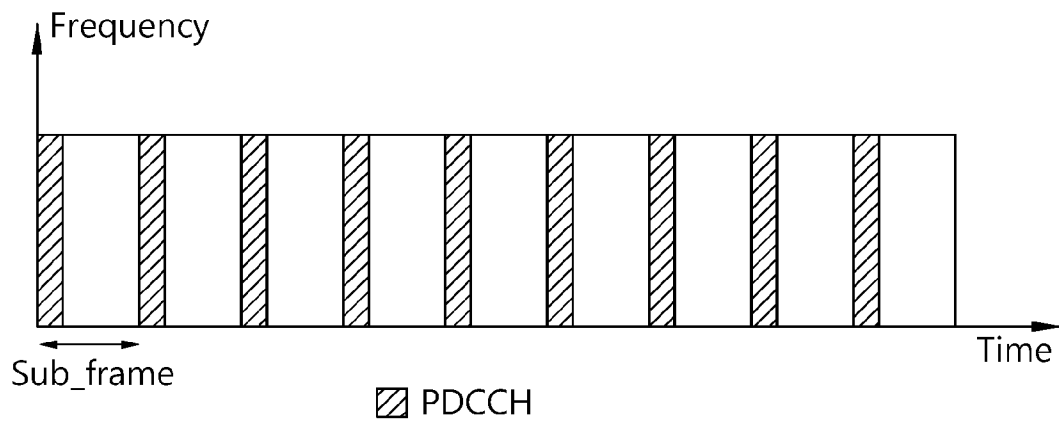

[Fig. 5]

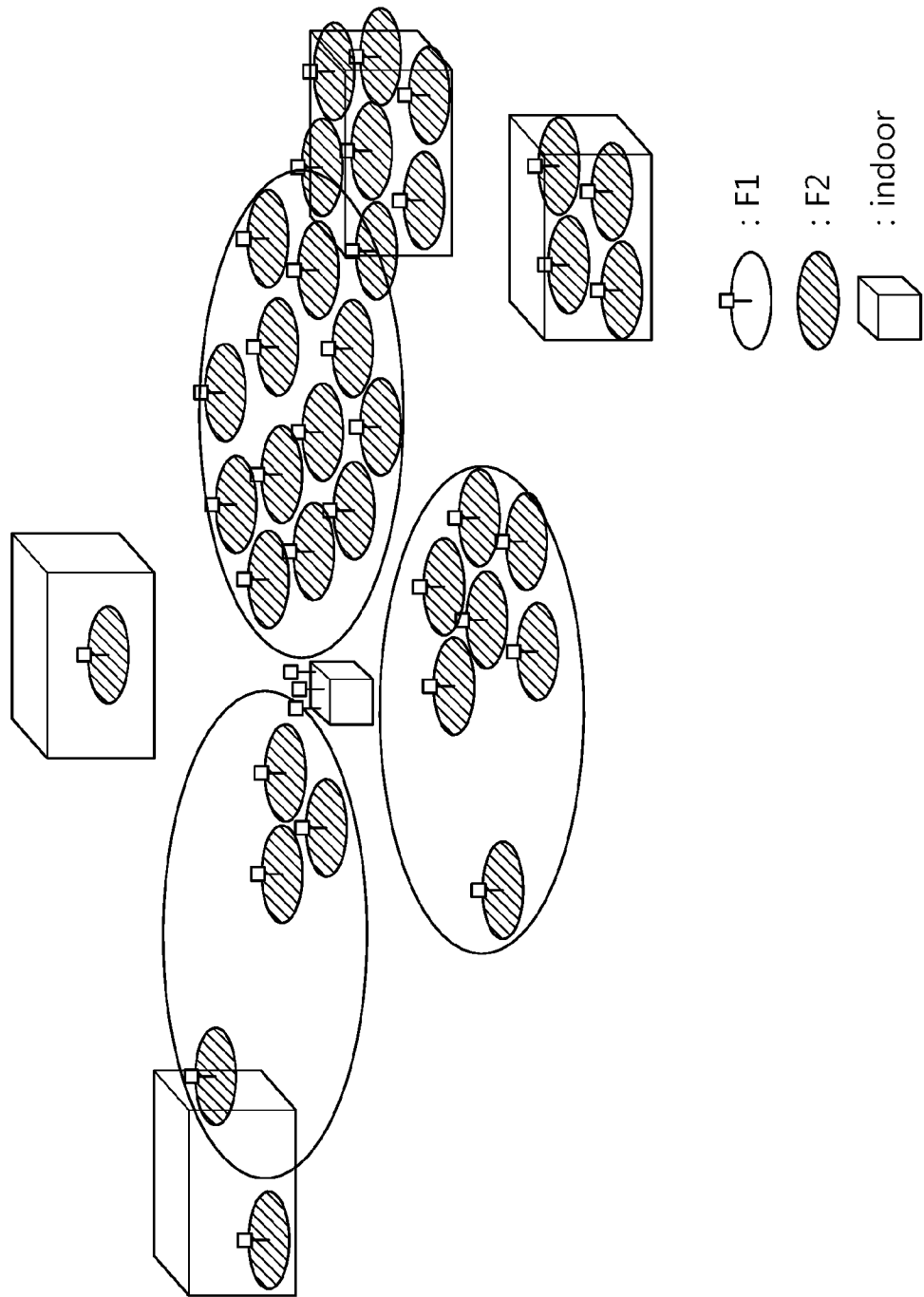

[Fig. 6]

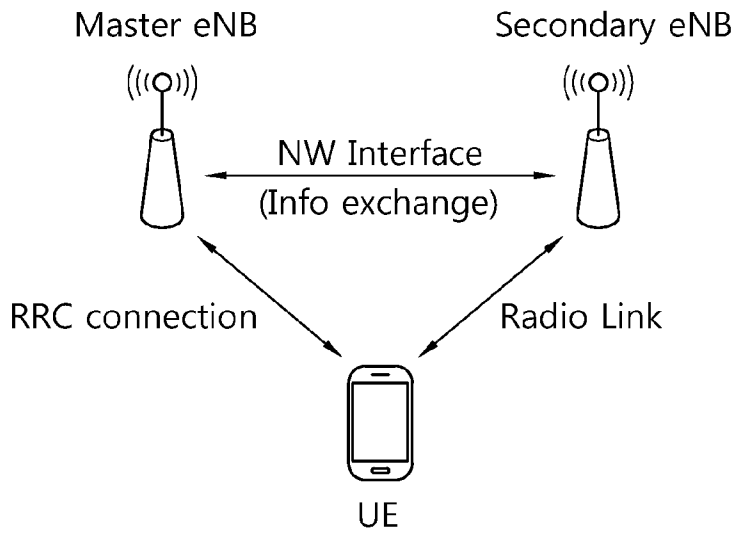

[Fig. 7]

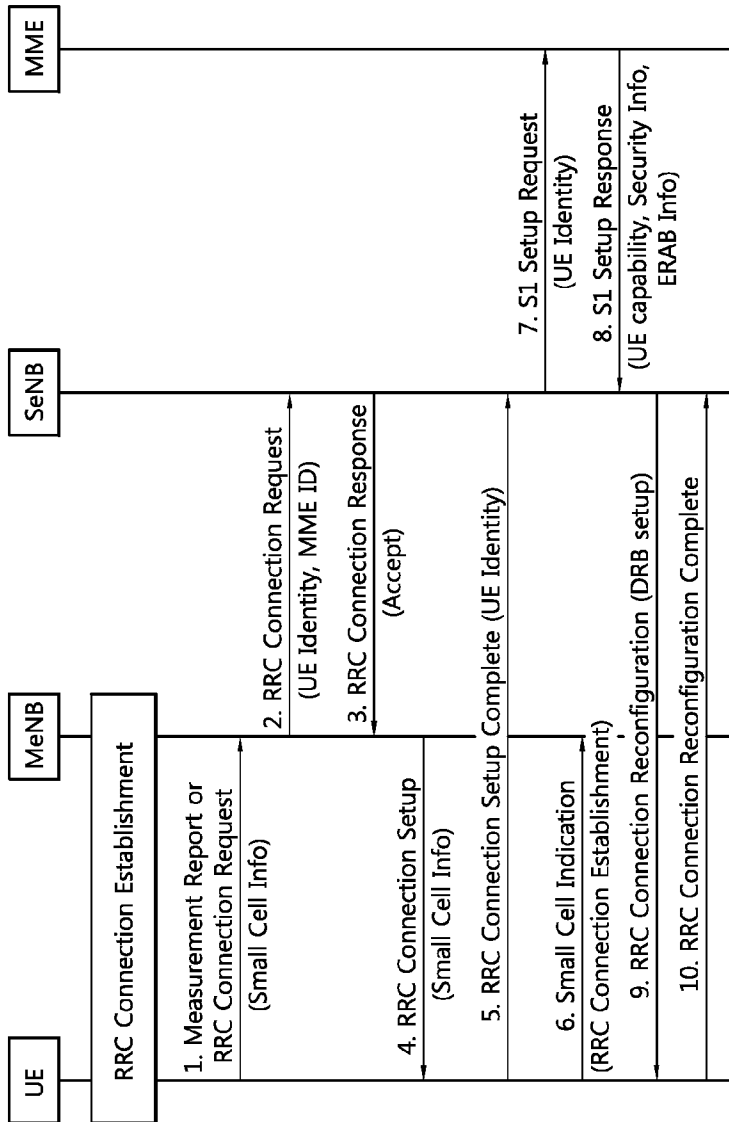

[Fig. 8]

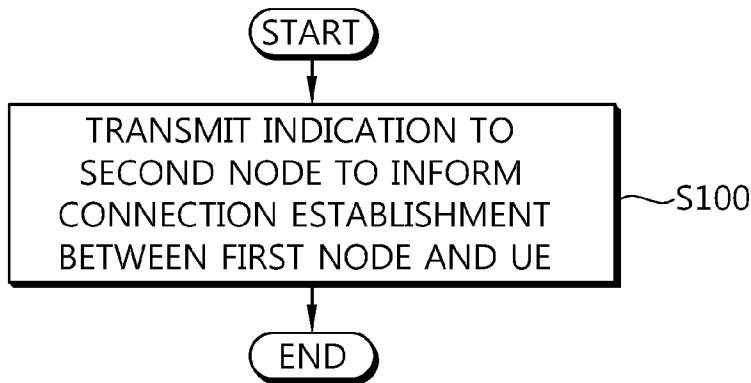

[Fig. 9]

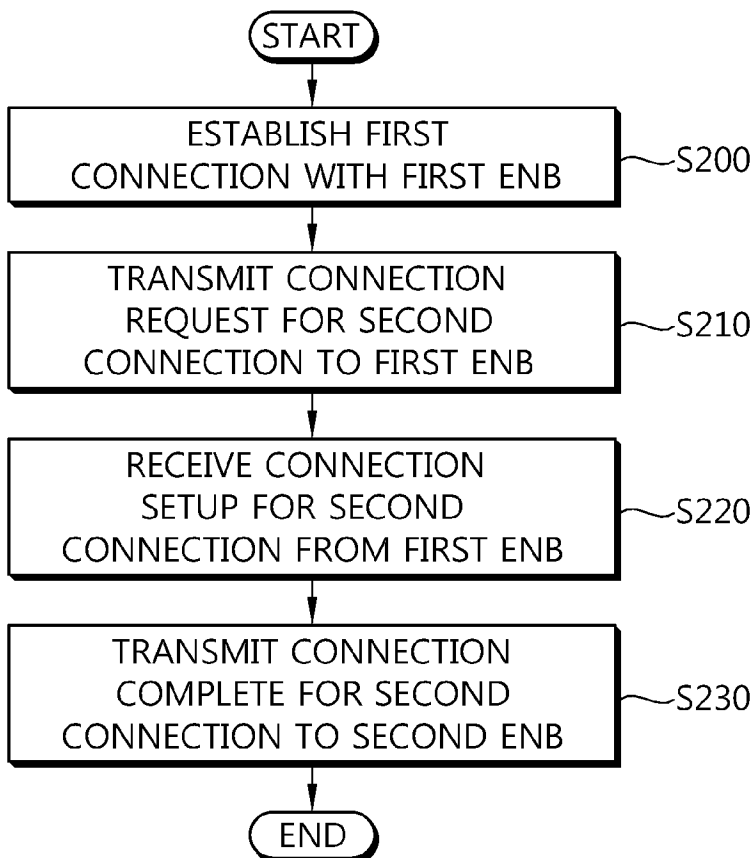

[Fig. 10]

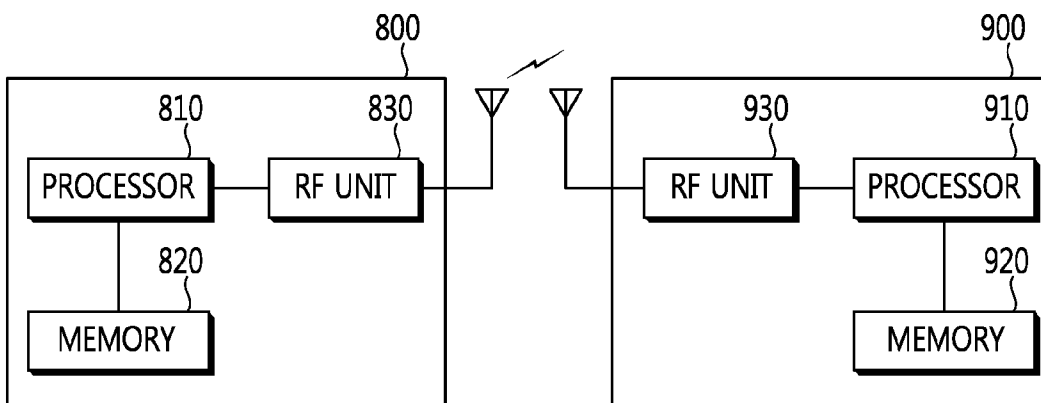

INTERNATIONAL SEARCH REPORT

International application No.
PCT/KR2014/000329**A. CLASSIFICATION OF SUBJECT MATTER****H04W 76/02(2009.01)i, H04W 16/24(2009.01)i**

According to International Patent Classification (IPC) or to both national classification and IPC

B. FIELDS SEARCHEDMinimum documentation searched (classification system followed by classification symbols)
H04W 76/02; H04Q 7/38; H04W 4/12; H04W 36/00; H04W 72/00; H04Q 7/32; H04W 16/24Documentation searched other than minimum documentation to the extent that such documents are included in the fields searched
Korean utility models and applications for utility models
Japanese utility models and applications for utility modelsElectronic data base consulted during the international search (name of data base and, where practicable, search terms used)
eKOMPASS(KIPO internal) & Keywords:RRC, dual layer connectivity, DRBs(data radio bearers), cell information**C. DOCUMENTS CONSIDERED TO BE RELEVANT**

Category*	Citation of document, with indication, where appropriate, of the relevant passages	Relevant to claim No.
X	US 2010-0080116 A1 (PARAG A. AGASHE et al.) 01 April 2010 See paragraphs [0041], [0042], [0046], [0067]-[0069], [0076], [0089]; claims 7, 27; and figure 2.	1,6
Y		2-5, 7, 10-13, 15
A		8, 9, 14
Y	WO 2012-019994 A1 (NOKIA SIEMENS NETWORKS OY) 16 February 2012 See page 8 lines 15-20; claim 1; and figure 1.	2-5, 11
Y	US 2009-0131063 A1 (SEUNG JUNE YI et al.) 21 May 2009 See paragraphs [0047], [0082], [0110]; claim 1; and figure 6	7, 10-13, 15
A	US 2011-0274030 A1 (HONG WANG et al.) 10 November 2011 See paragraphs [0046], [0047]; and figure 4.	1-15
A	WO 2008-113373 A1 (TELEFONAKTIEBOLAGET L M ERICSSON (PUBL) et al.) 25 September 2008 See page 8 lines 22-26; claim 1; and figure 3.	1-15

 Further documents are listed in the continuation of Box C. See patent family annex.

* Special categories of cited documents:

"A" document defining the general state of the art which is not considered to be of particular relevance

"E" earlier application or patent but published on or after the international filing date

"L" document which may throw doubts on priority claim(s) or which is cited to establish the publication date of another citation or other special reason (as specified)

"O" document referring to an oral disclosure, use, exhibition or other means

"P" document published prior to the international filing date but later than the priority date claimed

"T" later document published after the international filing date or priority date and not in conflict with the application but cited to understand the principle or theory underlying the invention

"X" document of particular relevance; the claimed invention cannot be considered novel or cannot be considered to involve an inventive step when the document is taken alone

"Y" document of particular relevance; the claimed invention cannot be considered to involve an inventive step when the document is combined with one or more other such documents, such combination being obvious to a person skilled in the art

"&" document member of the same patent family

Date of the actual completion of the international search

10 April 2014 (10.04.2014)

Date of mailing of the international search report

14 April 2014 (14.04.2014)

Name and mailing address of the ISA/KR

International Application Division
Korean Intellectual Property Office
189 Cheongsa-ro, Seo-gu, Daejeon Metropolitan City, 302-701,
Republic of Korea

Facsimile No. +82-42-472-7140

Authorized officer

KIM, Seong Woo

Telephone No. +82-42-481-3348



INTERNATIONAL SEARCH REPORT

Information on patent family members

International application No.

PCT/KR2014/000329

Patent document cited in search report	Publication date	Patent family member(s)	Publication date
US 2010-0080116 A1	01/04/2010	TW 201029507 A WO 2010-037133 A1	01/08/2010 01/04/2010
WO 2012-019994 A1	16/02/2012	EP 2604071 A1 KR 10-2013-0042009 A US 2013-0295915 A1	19/06/2013 25/04/2013 07/11/2013
US 2009-0131063 A1	21/05/2009	AT 400098 T AU 2004-240044 A1 AU 2004-240044 B2 BR PI0410265 A CN 100566212 C CN 101668249 A CN 101668249 B CN 1717880 A CN 1717880 C0 DE 602004014712 D1 EP 1566001 A1 EP 1566001 A4 EP 1566001 B1 HK 1081745 A1 JP 04174059 B2 JP 2006-512875 A KR 10-0548344 B1 KR 10-2004-0098126 A MX PA05006110 A RU 2005137938 A RU 2338320 C2 US 2004-0229626 A1 US 7463891 B2 US 8228852 B2 WO 2004-102837 A1	15/07/2008 25/11/2004 07/12/2006 16/05/2006 02/12/2009 10/03/2010 27/03/2013 04/01/2006 04/01/2006 14/08/2008 24/08/2005 22/03/2006 02/07/2008 23/04/2010 29/10/2008 13/04/2006 02/02/2006 20/11/2004 16/08/2005 20/06/2007 10/11/2008 18/11/2004 09/12/2008 24/07/2012 25/11/2004
US 2011-0274030 A1	10/11/2011	CN 102238667 A EP 2567593 A2 KR 10-2011-0123681 A US 8594011 B2 WO 2011-139112 A2 WO 2011-139112 A3	09/11/2011 13/03/2013 15/11/2011 26/11/2013 10/11/2011 19/04/2012
WO 2008-113373 A1	25/09/2008	WO 2008-113373 A8	05/03/2009