

(19)



(11)

**EP 3 929 145 B1**

(12)

**EUROPEAN PATENT SPECIFICATION**

(45) Date of publication and mention of the grant of the patent:

**07.08.2024 Bulletin 2024/32**

(51) International Patent Classification (IPC):

**B66F 17/00<sup>(2006.01)</sup> B66F 11/04<sup>(2006.01)</sup>**

(21) Application number: **21180411.7**

(52) Cooperative Patent Classification (CPC):

**B66F 17/006; B66F 11/044**

(22) Date of filing: **18.06.2021**

**(54) LIFTING SYSTEM FOR OPERATING MACHINES**

HEBESYSTEM FÜR ARBEITSMASCHINEN

SYSTÈME DE LEVAGE POUR MACHINES D'EXPLOITATION

(84) Designated Contracting States:

**AL AT BE BG CH CY CZ DE DK EE ES FI FR GB GR HR HU IE IS IT LI LT LU LV MC MK MT NL NO PL PT RO RS SE SI SK SM TR**

(72) Inventor: **IOTTI, Marco**

**42123 REGGIO EMILIA (IT)**

(30) Priority: **26.06.2020 IT 202000015508**

(74) Representative: **Gagliardelli, Fabrizio**

**Bugnion S.p.A.**

**Via M. Vellani Marchi 20**

**41124 Modena (IT)**

(43) Date of publication of application:

**29.12.2021 Bulletin 2021/52**

(56) References cited:

**EP-A1- 3 228 581**

**EP-A1- 3 392 192**

**JP-A- H10 337 336**

(73) Proprietor: **Manitou Italia S.r.l.**

**41013 Castelfranco Emilia (Modena) (IT)**

**EP 3 929 145 B1**

Note: Within nine months of the publication of the mention of the grant of the European patent in the European Patent Bulletin, any person may give notice to the European Patent Office of opposition to that patent, in accordance with the Implementing Regulations. Notice of opposition shall not be deemed to have been filed until the opposition fee has been paid. (Art. 99(1) European Patent Convention).

## Description

**[0001]** The present invention relates to a lifting system equipped with a loading platform and designed for use with self-propelled operating machines, such as telescopic handlers or telehandlers, aerial platforms or other like machines.

**[0002]** Loading platforms are known which comprise a bottom plane, designed for supporting operators, the load and work equipment, around which there are side panels designed to prevent accidental falling.

**[0003]** The platforms are able to be connected to a telescopic lifting arm, with which the work machines are provided, by means of attachment devices.

**[0004]** The known platforms of the "traditional" type operate with great effectiveness when they are used for work activities at height which require manual intervention by the operators, possibly with the use of portable tools which, as mentioned, can be easily loaded on the platform.

**[0005]** However, there are some types of work activities that cannot be carried out using platforms of this kind and they are therefore carried out inefficiently and, sometimes, dangerously.

**[0006]** Take, for example, the case of removing asbestos claddings present on the roofs of buildings, by removing the slabs forming the cladding.

**[0007]** In order to be able to remove asbestos claddings, or other material of similar type and/or dangerousness, it is necessary for one or more operators to work on the roofs, secured to a safety harness anchored to the roof.

**[0008]** In order to facilitate this operation, "special" platforms have been designed which are equipped with a movable side wall, that is to say, which can be tipped, thereby avoiding the need, when loading the sheets removed onto the bottom surface of the platform, to pass them over the side walls, which is an operation that is awkward and laborious, as well as risky, due to the type of material being moved.

**[0009]** An example of this second type of platform is described in European patent no. 3392192 in the name of the same Applicant as this invention.

**[0010]** In principle, the special platforms with side walls which can be tipped would have a greater risk of falling compared with those with fixed sides; however, the invention protected by the above-mentioned European patent comprises a system for consent and inhibiting based on a logic which guarantees that the operators cannot be close to the free edge of the tipped side wall, when the platform is moved, thus preventing the possibility of falling.

**[0011]** However, the state authorities of some countries require that, in order to authorise the use of platforms with tipping side walls, these must be equipped with mechanisms that guarantee that the operators who climb on board them are using individual physical protection devices, such as slings fixed to the platforms, which pre-

vent their falling. JP H10 337336 A discloses the preamble of claim 1.

**[0012]** The technical purpose which forms the basis of the invention is to propose a loading platform which, included in an innovative lifting system, makes it possible to satisfy the need indicated in the previous paragraph.

**[0013]** This technical purpose is achieved by the lifting system made according to claim 1.

**[0014]** Further characteristics and advantages of the present invention will become more apparent from the following indicative, and hence non-limiting, description of preferred, but not exclusive, embodiments of the system of the invention, as illustrated in the accompanying drawings, in which:

- Figures 1 and 2 are axonometric views of the loading platform according to the invention, in different working configurations;
- Figure 3 is an axonometric view of a telehandler which includes the lifting system according to the invention; and
- Figure 4 is a schematic representation of the processing means according to the invention.

**[0015]** With reference to the above-mentioned drawings, the numeral 1 denotes a loading platform for a telehandler 2, an aerial platform or similar work machines.

**[0016]** The platform 1 according to the invention is especially designed to be connected to a lifting arm 21 with which the work machine 2 is equipped. Hereinafter, for convenience of illustration and without limiting the scope of the invention, reference will be made to the particular case in which the operating machine is a telehandler 2 (see Figure 3).

**[0017]** Apart from some special technical features, which are the object of the invention and will be described in detail below, the lifting system according to the invention, including its platform, may be like the one described in the above-mentioned European patent No. 3392192 in the name of the same Applicant as this invention.

**[0018]** The platform 1 comprises a bottom plane 10, set up for supporting the operators and/or the work equipment.

**[0019]** The plane 10 is associated with side walls 11, 12, 13, 14 to prevent accidental falling of the operators or the load.

**[0020]** In particular, the plane 10 is preferably quadrangular (for example rectangular) and, therefore, the side walls 11, 12, 13, 14 are located at the perimeter of the plane 10, from which they extend to form a sort of open-topped cage.

**[0021]** The lifting arm 21 is movable and, preferably, telescopic; in detail, the arm 21 comprises a plurality of segments, inserted with the possibility of sliding one in the other, of which a proximal segment hinged to the frame of the machine 2 or to a relative rotary tower, and a distal segment which mounts the attachment device 22 for removably coupling the platform 1.

**[0022]** The platform 1 is equipped with an hooking device 15 designed for anchoring to the attachment device 22 of the arm 21, in a known manner. It should be noted that the platform 1 may be rotatable relative to an axis which passes through the hooking device 15; in particular, the device 15 may include a hinge on which a movement device acts, preferably of the hydraulic type, acts.

**[0023]** In general, the movements of the arm 21 are preferably achieved by means of a drive apparatus 24, 25, 26, which may include hydraulic cylinders 25, 26, activated by one or more electro-hydraulic distributors 24, not illustrated because they can also be of known type.

**[0024]** The invention also relates to the case in which the movement devices are of the electro-mechanical type and not hydraulic.

**[0025]** The platform 1 according to the invention has been designed to pass from a first to a second operating configuration and vice versa.

**[0026]** More in detail, the first operating configuration (shown in Figure 1) may be a configuration of normal use whilst the second configuration (shown in Figure 2) may be used for special purposes, such as, for example, removal of sheets of asbestos from roof coverings or similar uses.

**[0027]** According to the invention, shown in the accompanying drawings, at least one of the side walls 11, 12, 13, 14 which surround the bottom plane 10 may be movable between an upright position, to define a first configuration of normal use of the platform 1 and a lowered position, to define a second configuration for special use of the platform 1.

**[0028]** More precisely, when the movable side wall 11 is in the lowered position, the platform 1 is in an open configuration which allows the material to be introduced or supported, whilst in the upright position the platform 1 is closed on all sides.

**[0029]** Preferably, the movable side wall 11 can be tipped, that is to say, it is designed to rotate between the upright position wherein it is substantially perpendicular to the bottom 10, like the other side walls 12, 13, 14, to a lowered position in which it defines an extension of the bottom plane 10, and is therefore parallel and/or consecutive to the bottom surface. Preferably, the movable side wall 11 is the outermost or "front" side wall, that is, the one opposite the rear side wall 12 which has the hooking device 15.

**[0030]** More in detail, the side wall 11 which can be tipped is hinged to the bottom 10 at its lower side; auxiliary means may be provided for moving the side wall 11 between its various positions, which connect the movable side wall 11 and the bottom of the platform 1, such as, for example, gas springs, hydraulic cylinders 25, 26, etc.

**[0031]** In order that it can be used together with the base 10 as a support for the load, the movable side wall 11 is equipped with a continuous surface, substantially equal to that of the bottom of the platform 1, for example comprising a sheet 110 at least partly made of metal, for

example aluminium.

**[0032]** Still more in detail, the side walls 11, 12, 13, 14 may be of the reticular (or "lattice" type), with the lattice of the movable side wall 11 which has fixed the above-mentioned continuous surface.

**[0033]** Moreover, at the relative longitudinal ends, the movable side wall 11 may be equipped with two sub-side walls 111, 112 or parapets, to define, in the special operating configuration, extensions of the two fixed side walls 13, 14 positioned between the movable side wall 11 and the rear side wall 12. The two sub-side walls 111, 112 may be hinged to the movable side wall 11 and can be fixed manually in a position in which they are perpendicular to the movable side wall 11.

**[0034]** The invention includes a side wall sensor designed to check whether the platform 1 is in the first or second operating configuration.

**[0035]** The side wall sensor is designed to check whether the above-mentioned movable side wall 11 is in the upright position or whether it is in the lowered position.

**[0036]** There is also at least one control apparatus, which can be operated directly by an operator and set up to control the hydraulic distributor 24, in such a way that it moves the arm 21 (and, if necessary, the tower and the rotation joint of the platform 1, if present) according to the commands selected by the operator.

**[0037]** More specifically, the control apparatus is connected to processing means 3, which may also consist of or comprise the control unit on the telehandler 2, which produce control signals which drive the electro-hydraulic distributor 24 which activates the hydraulic cylinders 25, 26 of the arm 21 (and also the motor of the rack which causes the rotation of the tower, if present).

**[0038]** The control apparatus comprises an interface, consisting for example of a joystick, pushbuttons, display (also touchscreen), levers and the like, the activation of which allows the operator to select the commands for moving the arm 21.

**[0039]** In more general terms, the interface of the control apparatus is configured to allow the setting or selection of position parameters, representing the movement of the arm 21 both in relation to the inclination relative to the frame of the machine 2 and in relation to the extension and shortening of the arm 21.

**[0040]** The control apparatus, which may also be of known type and therefore not shown, is designed to generate control signals, as a function of the selections performed on the relative interface, whilst the processing means 3 are designed to receive these control signals and to generate and transmit to the distributor 24 drive signals as a function of the control signals received.

**[0041]** In the solution according to European patent No. 3392192, there are two control apparatuses, one of which is mounted on the platform 1, which may be used by the operators on board the platform and one located in the cab 23 of the telehandler 2, which can be used by the operator who drives the vehicle 2.

**[0042]** The cab control apparatus can be like those al-

ready in use in this type of vehicle. Alternatively or in addition, there may be an external apparatus, for example equipped with a remote control which can be operated by an operator outside the cab 23 of the machine 2.

**[0043]** The invention of the above-mentioned European patent advantageously allows switching the control of the movements of the arm 21 and of the platform 1 from the control apparatus on the platform 1 to the one in the cab (or outside) and vice versa, according to the different operating conditions and the various uses of the platform 1, in order to always maintain the highest degree of safety and efficiency of use.

**[0044]** However, the invention may also be applied to solutions which do not provide this aspect of the security system of European patent No. 3392192. This invention has been conceived in such a way as to guarantee that, especially when the platform 1 is in the open configuration, that is to say, with the movable side wall 11 lowered, it cannot be moved by the arm 21 or by its joint, unless the operators on board are wearing protective devices 41, 42 which physically anchor them to the platform 1.

**[0045]** In general terms, the invention comprises, for each operator positioned on the platform, a safety device 41, 42 which can be worn for fastening him/her securely to the platform 1, such as, for example, a sling 41 connected by a cable 42 to the platform 1, preferably to a side wall 12.

**[0046]** In the example shown, the slings 41 are both connected by the anchoring cable 42 to the innermost side wall 12, opposite to the movable one. According to an important aspect of the invention, checking means 5 are provided which are designed to detect whether the safety device 41, 42 is worn by the respective operator.

**[0047]** Moreover, the above-mentioned processing means 3 are configured to allow or inhibit operation of the above-mentioned drive apparatus 24, 25, 26, which includes the hydraulic actuators 25, 26 of the arm 21 and of the platform 1, based on the detection performed by the checking means. More in detail, the processing means 3 may be configured in such a way as to allow the operation of the hydraulic actuators 25, 26 which move the arm 21 and platform 1 if and only if the checking means detect that each safety device 41, 42 implemented on the platform 1 is worn by a relative operator. According to a particular embodiment, the checking means comprise an electric circuit 5 normally open which may be closed following wearing of the protective device 41, 42, thereby generating an electrical checking signal which is transmitted to the processing means 3 for its detection. For example, the circuit 5 may comprise two branches 51, 52 mounted on the sling 41 (schematically illustrated in Figure 4) and provided at the free ends with respective terminals, designed to be connected to each other by the operator wearing the sling 41, so as to close the circuit 5, thereby allowing the electrical signal to flow in the circuit 5 and be detected by the processing means 3.

**[0048]** In practice, parallel with the fastening cable 42

of the sling 41, there may be a second cable 53 for transmitting electrical signals which comprises a first terminal, for example a jack, which is electrically connected to an inlet present on the platform 1 and which, at the other end, is joined to the back of the sling 41, where it splits into the two branches 51, 52 mentioned, incorporated or attached to the sling 41, which slide on the sides of the sling 41 preferably at the position of the waist of the operator.

**[0049]** In this case, the platform 1 has various electrical inputs to which the second cable 53 is connected, the inputs being connected to the electrical system of the machine 1, which is in turn connected to the processing means 3. Alternatively, the second cables 53 of the safety devices on the platform 1 might be permanently connected to the electrical system of the telehandler 1.

**[0050]** For this reason, when the operator wears the sling 41, after inserting the first terminal at the platform 1 entrance, connects the other two terminals present in the sling 41 to the height of the waist, thereby closing the circuit 5 and allowing transmission of the first checking signal.

**[0051]** More generally speaking, according to the invention, the above-mentioned checking means are designed to transmit a first checking signal, as a function of the detection performed, which does not necessarily need to be an electrical signal, but may be an optical signal or other type; this signal is in any case processed by the processing means 3, which inhibit or allow operation of the drive apparatus 24, 25, 26 based on the checking signal.

**[0052]** For example, the processing means 3 can assess the presence or absence of checking signals or assess a measurement of the value of the signals received and determine whether or not to allow the electro-hydraulic distributor 24 to activate the hydraulic actuators 25, 26 according to how the operator is operating the control apparatus.

**[0053]** More in detail, when the processing means 3 receive the control signals from the control apparatus, regardless of whether it is on the platform 1 or in the cab 23, they transmit suitable drive signals to the distributor 24 only if they have detected checking signals indicating the fact that the slings 41 have been worn and therefore the safety conditions are satisfied to allow the platform 1 to be moved.

**[0054]** It should be noted that, as an alternative to the solution with an electrical circuit 5 which is normally open, the checking means may include a sensor, positioned on the safety device 41, 42, designed to detect whether the latter is worn and to consequently produce said checking signal; for example, there may be a presence sensor associated with a buckle of the sling 41 which detects whether the sling is connected.

**[0055]** The above-mentioned side wall sensor 6 (shown in a stylised form in Figure 4), which is designed to detect the position of the movable side wall 11, produces a second checking signal, depending on the po-

sition detected, which is processed by the processing means 3, together with the first checking signal on the wearing of the protective devices 41, 42.

**[0056]** In this case, the drive apparatus 24, 25, 26 which regulates the movement of the platform 1 is actuated or inhibited according to conditions relating to both types of check signals.

**[0057]** For example, it may be established that the checking on the condition of wearing the slings 41 by the operators on the platform 1 conditions the actuation or inhibition of the movements of the arm 21 and of the platform 1 only if the movable side wall 11 is in the lowered position, that is to say, when the risk of falling is greater.

**[0058]** In this case, the processing means 3 inhibit the activation of the hydraulic actuators 25, 26 by the distributor 24 only if the second checking signal represents the condition of side walls 11 overturned but a checking signal has not been processed which represents the condition of the sling 41 worn or not all the slings 41 connected on the platform 1 are worn, based on the respective checking signals.

**[0059]** It should be noted that whilst the length of the first anchoring cable 42 of the sling 41 is such as to prevent the operator wearing it from positioning him/herself at or beyond the free outer edge of the movable side wall 11 in the lowered position, the second cable 53, set up for electrical conduction, may be a much longer cable, for example configured like a spiral spring which surrounds the first cable 42.

**[0060]** Still more in detail, the processing means 3 can include a memory module 31 for recording the number of safety devices 41, 42 carried on the platform 1 and which must be worn.

**[0061]** Moreover, the processing means 3 may include a connection module 32 configured for detecting how many protective devices 41, 42 are connected to the electrical system of the machine, through the inputs present on the platform 1 and to record this number in the memory module 31.

**[0062]** The processing means 3 then comprise a first safety module 33, connected to the memory module 31 and configured to determine whether all the safety devices 41, 42 are worn, as a function of the first checking signals detected. A second safety module 34 may be provided to determine whether the movable side wall 11 is in the lowered position, on the basis of the second check signal.

**[0063]** There is also a control module 35 configured for transmitting to the hydraulic distributor 24 control signals designed to control the drive apparatus 24, 25, 26 as a function of the control signals received from the above-mentioned control apparatuses.

**[0064]** Lastly, the processing means 3 can include an enabling module 36 configured to allow or inhibit the operation of the drive module on the basis of the fact that the first and the second safety module 33, 34 have determined whether the movable side wall 11 is lowered and if all the safety devices 41, 42 are worn.

**[0065]** It should be noted that the processing means may comprise a processing unit 3 which is presented as divided into separate functional modules for the purpose of describing the functions clearly and completely. In practice, the processing unit may consist of an electronic device, also of the type commonly present on this type of machines and platforms, such as the control unit mentioned above, suitably programmed to perform the functions described.

**[0066]** The various modules can correspond to hardware units and/or software routines forming part of the programmed device.

**[0067]** The functions can be performed by a plurality of electronic devices on which the above-mentioned functional modules can be distributed.

**[0068]** Generally speaking, the processing unit may have one or more microprocessors or microcontrollers for execution of the instructions contained in the memory modules and the above-mentioned functional modules may also be distributed on a plurality of local or remote calculators based on the architecture of the network in which they reside.

## Claims

1. A lifting system for work machines (2), comprising:
  - a loading platform (1);
  - a movable lifting arm (21) on which said platform (1) is mounted;
  - at least one drive apparatus (24, 25, 26) for moving said arm (21);
  - at least one safety device (41, 42) which can be worn by an operator and designed to securely fasten the latter to the platform (1);
  - checking means (5) designed to detect whether said safety device (41, 42) is worn by an operator; and
  - processing means (3), configured to allow or inhibit operation of said drive apparatus (24, 25, 26), on the basis of the detection performed by the checking means (5);
  - wherein said checking means (5) are designed to transmit a first checking signal, as a function of the detection performed, which is processed by the processing means (3), which inhibit or allow the operation of the drive apparatus (24, 25, 26) on the basis of the checking signal;
  - characterized in that** the platform (1) comprises a bottom surface (10) and a plurality of side walls (11, 12, 13, 14), of which at least one side wall (11) movable between an upright position, to define a first configuration of normal use of the platform (1) and a lowered position, to define a second configuration of special use of the platform (1), the system also comprising a side sensor (6) designed to detect the position of said

- movable side wall (11) and to produce a second checking signal, as a function of the position detected;
- the above-mentioned processing means (3) being configured to allow or inhibit an operation of said drive apparatus (24, 25, 26) as a function of the first and the second checking signal.
2. The system according to the preceding claim, wherein the safety device (41, 42) is a sling (41) connected by a cable (42) to the platform (1).
  3. The system according to the preceding claim, wherein the checking means comprise an electric circuit (5) normally open which may be closed following wearing of the protective device (41, 42), thereby generating an electrical checking signal.
  4. The system according to the preceding claim, wherein said circuit (5) comprises two branches (51, 52) positioned on the sling (41) provided at the free end with respective terminals, designed to be connected by the operator so as to close the circuit.
  5. The system according to claim 1 or claim 2, wherein the checking means include at least one sensor, positioned on the safety device (41, 42), designed to detect whether the latter is worn and consequently produce said checking signal.
  6. The system according to claim 2, wherein said cable (42) of the sling (41) has a length such as to prevent the operator wearing it from positioning at and beyond the free outer edge of the movable wall (11) in the lowered position.

#### Patentansprüche

1. Hubsystem für Arbeitsmaschinen (2), umfassend:
  - eine Ladeplattform (1);
  - einen beweglichen Hubarm (21), auf dem die Plattform (1) montiert ist,
  - zumindest eine Antriebsvorrichtung (24, 25, 26) zum Bewegen des Arms (21);
  - zumindest eine Sicherheitsvorrichtung (41, 42), die von einer Bedienperson am Körper angelegt werden kann und die dafür ausgelegt ist, diese sicher an der Plattform (1) zu befestigen;
  - Überprüfungsmittel (5), die dafür ausgelegt sind, zu erkennen, ob die Sicherheitsvorrichtung (41, 42) von einer Bedienperson am Körper getragen wird; und
  - Verarbeitungsmittel (3), die dafür konfiguriert sind, den Betrieb der Antriebsvorrichtung (24, 25, 26) auf Grundlage der von den Überprüfungsmitteln (5) durchgeführten Erkennung zu

erlauben oder zu verhindern;

wobei die Überprüfungsmittel (5) dafür ausgelegt sind, ein erstes Überprüfungssignal, in Abhängigkeit von der durchgeführten Erkennung, auszusenden, das von den Verarbeitungsmitteln (3) verarbeitet wird,

welche den Betrieb der Antriebsvorrichtung (24, 25, 26) auf Grundlage des Überprüfungssignals erlauben oder verhindern;

**dadurch gekennzeichnet, dass** die Plattform (1) eine untere Oberfläche (10) und eine Vielzahl von seitlichen Wänden (11, 12, 13, 14) umfasst, von denen zumindest eine seitliche Wand (11) bewegbar ist zwischen einer aufrechten Stellung, um eine erste Konfiguration des normalen Gebrauchs der Plattform (1) zu definieren, und einer abgesenkten Stellung, um eine zweite Konfiguration des besonderen Gebrauchs der Plattform (1) zu definieren, wobei das System ferner einen Sensor (6) für die seitliche Wand umfasst, der dafür ausgelegt ist, die Stellung der beweglichen seitlichen Wand (11) zu erkennen und ein zweites Überprüfungssignal zu erzeugen, das von der erkannten Stellung abhängig ist,

wobei die oben genannten Verarbeitungsmittel (3) dafür konfiguriert sind, den Betrieb der Antriebsvorrichtung (24, 25, 26) in Abhängigkeit von dem ersten und dem zweiten Überprüfungssignal zu erlauben oder zu verhindern.

2. System nach dem vorhergehenden Anspruch, wobei die Sicherheitsvorrichtung (41, 42) ein Anseilgurt (41) ist, der über ein Seil (42) mit der Plattform (1) verbunden ist.
3. System nach dem vorhergehenden Anspruch, wobei die Überprüfungsmittel einen elektrischen Schaltkreis (5) mit stromlos geöffnetem Arbeitskontakt umfassen, der infolge des Anlegens der Sicherheitsvorrichtung (41, 42) geschlossen werden kann, um somit ein elektrisches Überprüfungssignal zu erzeugen.
4. System nach dem vorhergehenden Anspruch, wobei der Schaltkreis (5) zwei Abzweigungen (51, 52) umfasst, die auf dem Anseilgurt (41) angeordnet und an ihrem freien Ende jeweils mit entsprechenden Endklemmen versehen sind, die dafür konfiguriert sind, von der Bedienperson miteinander verbunden zu werden, um den Schaltkreis zu schließen.
5. System nach Anspruch 1 oder Anspruch 2, wobei die Überprüfungsmittel zumindest einen Sensor umfassen, der auf der Sicherheitsvorrichtung (41, 42) angeordnet und dafür ausgelegt ist, zu erkennen, ob diese am Körper angelegt ist, und dementsprechend das Überprüfungssignal zu erzeugen.

6. System nach Anspruch 2, wobei das Seil (42) des Anseilgurts (41) eine Länge aufweist, die so beschaffen ist, dass sie verhindert, dass die Bedienperson, die den Gurt am Körper angelegt hat, sich an oder jenseits der freien äußeren Kante der in der abgesenkten Stellung befindlichen beweglichen Wand (11) positionieren kann.

### Revendications

1. Un système de levage pour machines de travail (2), comprenant :

une plateforme de chargement (1) ;

un bras de levage (21) mobile sur lequel ladite plateforme (1) est montée ;

au moins un appareil d'actionnement (24, 25, 26) pour mouvoir ledit bras (21) ;

au moins un dispositif de sécurité (41, 42) qui peut être porté par un opérateur et destiné à attacher solidement ce dernier à la plateforme (1) ;

des moyens de vérification (5) destinés à détecter si ledit dispositif de sécurité (41, 42) est porté par un opérateur ; et

des moyens de traitement (3), configurés pour permettre ou inhiber le fonctionnement dudit appareil d'actionnement (24, 25, 26), en fonction de la détection effectuée par les moyens de vérification (5) ;

dans lequel lesdits moyens de vérification (5) sont destinés à transmettre un premier signal de vérification, en fonction de la détection effectuée,

qui est traité par les moyens de traitement (3), qui inhibent ou permettent le fonctionnement de l'appareil d'actionnement (24, 25, 26) en fonction du signal de vérification ;

**caractérisé en ce que** la plateforme (1) comprend une surface de fond (10) et une pluralité de parois latérales (11, 12, 13, 14), dont au moins une paroi latérale (11) mobile entre une position dressée, pour définir une première configuration d'utilisation normale de la plateforme (1), et une position abaissée, pour définir une deuxième configuration d'utilisation spéciale de la plateforme (1), le système comprenant également un capteur de surface latérale (6) destiné à détecter la position de ladite paroi latérale (11) et à produire un deuxième signal de vérification en fonction de la position détectée ;

les moyens de traitement (3) susmentionnés étant configurés pour permettre ou inhiber un fonctionnement dudit appareil d'actionnement (24, 25, 26) en fonction du premier et du deuxième signal de vérification.

2. Le système selon la revendication précédente, dans lequel le dispositif de sécurité (41, 42) est un harnais (41) relié par un câble (42) à la plateforme (1) .

3. Le système selon la revendication précédente, dans lequel les moyens de vérification comprennent un circuit électrique (5) normalement ouvert qui peut être fermé suite au port du dispositif de sécurité (41, 42), ce qui génère un signal électrique de vérification.

4. Le système selon la revendication précédente, dans lequel ledit circuit (5) comprend deux branches (51, 52) positionnées sur le harnais (41) dotées à l'extrémité libre de bornes respectives, destinées à être connectées par l'opérateur de manière à fermer le circuit.

5. Le système selon la revendication 1 ou la revendication 2, dans lequel les moyens de vérification comprennent au moins un capteur, positionné sur le dispositif de sécurité (41, 42), destiné à détecter si ce dernier est porté et à produire en conséquence ledit signal de vérification.

6. Le système selon la revendication 2, dans lequel ledit câble (42) du harnais (41) a une longueur de nature à empêcher l'opérateur qui le porte de se positionner au niveau de et au-delà du bord extérieur libre de la paroi mobile (11) dans la position abaissée.

Fig.1

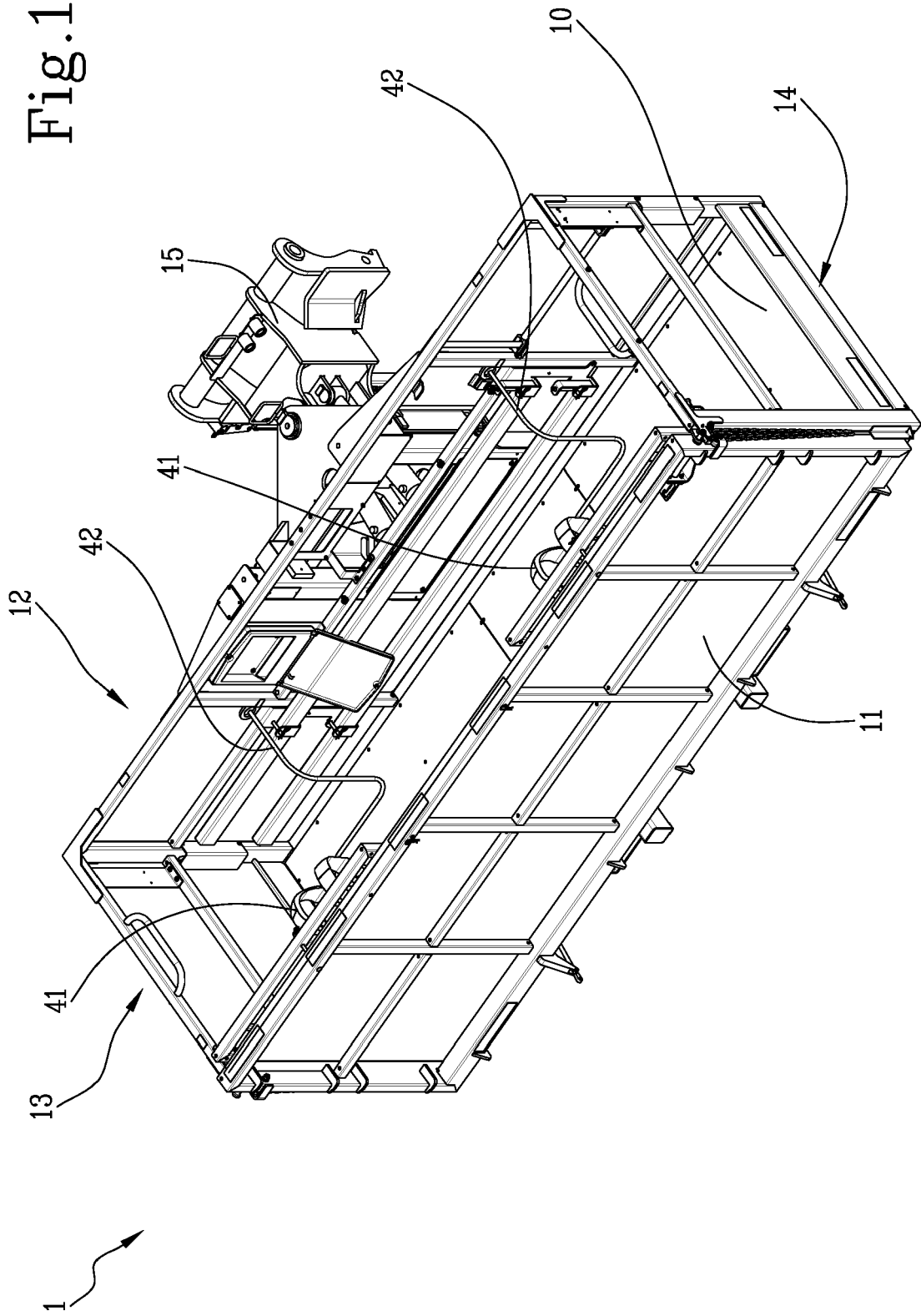

Fig. 2

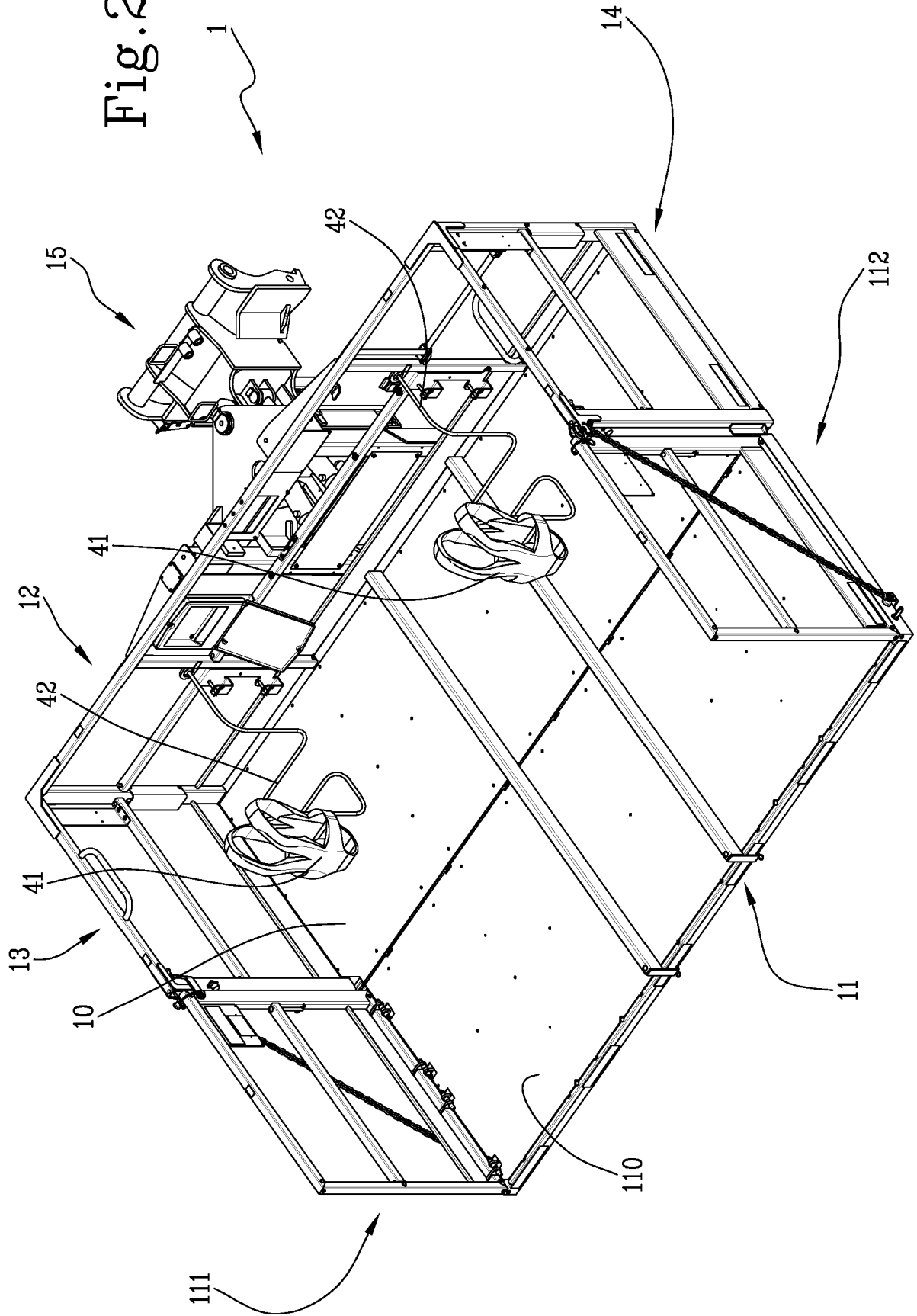
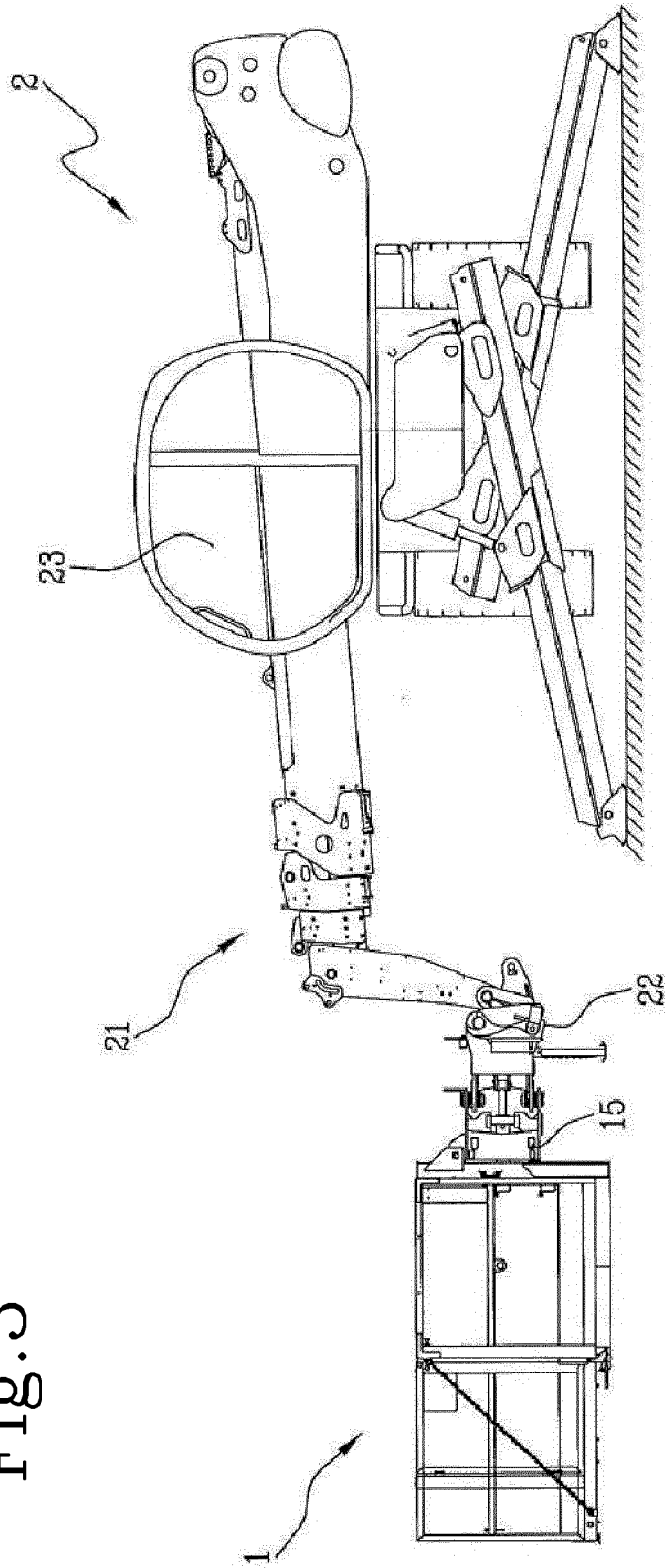

Fig. 3



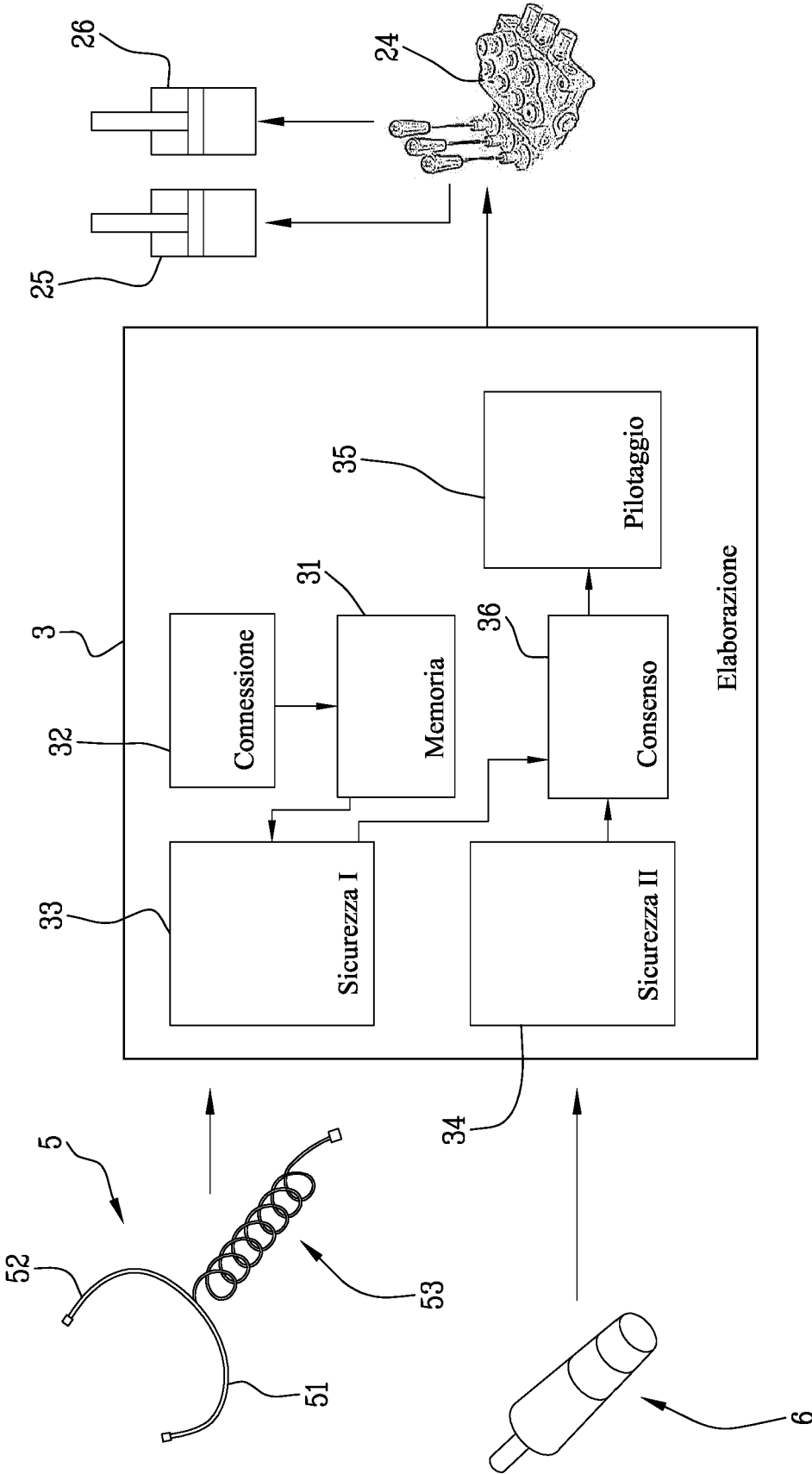

Fig.4

**REFERENCES CITED IN THE DESCRIPTION**

*This list of references cited by the applicant is for the reader's convenience only. It does not form part of the European patent document. Even though great care has been taken in compiling the references, errors or omissions cannot be excluded and the EPO disclaims all liability in this regard.*

**Patent documents cited in the description**

- EP 3392192 A [0009] [0017] [0041] [0044]
- JP H10337336 A [0011]