



- (51) International Patent Classification:
A61F 2/50 (2006.01) A61F 2/76 (2006.01)
A61F 2/54 (2006.01)
- (21) International Application Number:
PCT/US2016/016215
- (22) International Filing Date:
2 February 2016 (02.02.2016)
- (25) Filing Language: English
- (26) Publication Language: English
- (30) Priority Data:
62/111,436 3 February 2015 (03.02.2015) US
62/209,826 25 August 2015 (25.08.2015) US
- (71) Applicant: RCM ENTERPRISE, LLC [US/US]; 909 Trosper Road, SW, Suite 102, Tumwater, Washington 98512 (US).
- (72) Inventors: THOMPSON, JR., Robert; 909 Trosper Road, SW, Suite 102, Tumwater, Washington 98512 (US). BENGTSOON, Jon; 909 Trosper Road, SW, Suite 102, Tumwater, Washington 98512 (US). PETO, Anthony Charles; 909 Trosper Road, SW, Suite 102, Tumwater,

Washington 98512 (US). MACDUFF, Charles Colin; 909 Trosper Road, SW, Suite 102, Tumwater, Washington 98512 (US). MINNIS, Sydney Tye; 909 Trosper Road, SW, Suite 102, Tumwater, Washington 98512 (US). KLUMPER, Eric Dennis; 909 Trosper Road, SW, Suite 102, Tumwater, Washington 98512 (US). CRITTENDEN, Bradley Arthur; 909 Trosper Road, SW, Suite 102, Tumwater, Washington 98512 (US).

(74) Agents: SHERIDAN, James A. et al.; 1600 Jackson Street, Suite 350, Golden, Colorado 80401 (US).

(81) Designated States (unless otherwise indicated, for every kind of national protection available): AE, AG, AL, AM, AO, AT, AU, AZ, BA, BB, BG, BH, BN, BR, BW, BY, BZ, CA, CH, CL, CN, CO, CR, CU, CZ, DE, DK, DM, DO, DZ, EC, EE, EG, ES, FI, GB, GD, GE, GH, GM, GT, HN, HR, HU, ID, IL, IN, IR, IS, JP, KE, KG, KN, KP, KR, KZ, LA, LC, LK, LR, LS, LU, LY, MA, MD, ME, MG, MK, MN, MW, MX, MY, MZ, NA, NG, NI, NO, NZ, OM, PA, PE, PG, PH, PL, PT, QA, RO, RS, RU, RW, SA, SC, SD, SE, SG, SK, SL, SM, ST, SV, SY, TH, TJ, TM, TN, TR, TT, TZ, UA, UG, US, UZ, VC, VN, ZA, ZM, ZW.

[Continued on next page]

- (54) Title: BIO-MECHANICAL PROSTHETIC FINGER WITH Y-SHAPED ROCKER

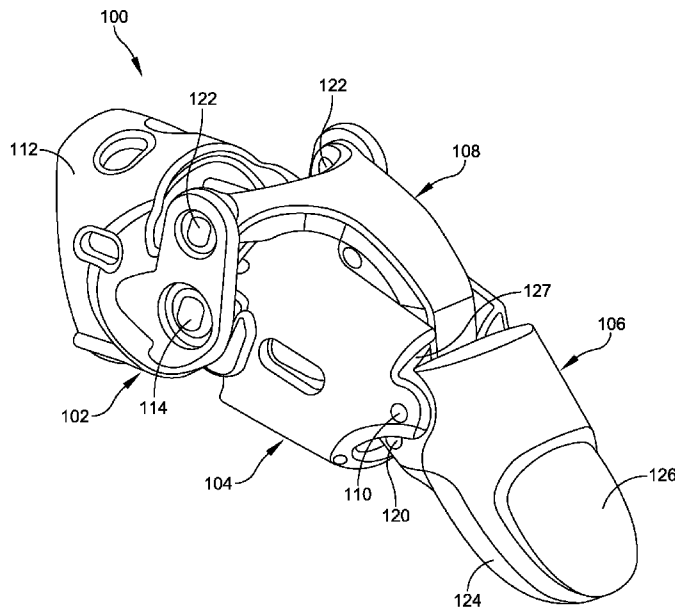

FIG. 1

(57) Abstract: The disclosure provides apparatus and methods of use pertaining to a prosthetic finger assembly. In one embodiment, the assembly includes a coupling tip and a distal ring coupled with the coupling tip. The assembly further includes a proximal ring coupled with the distal ring. A rocker formed in a Y-shaped with a first end forming a single prong and a second end forming a split prong may extend between the coupling tip and the proximal ring. The coupling tip, distal ring, proximal ring, and Y-shaped rocker may all be hingedly connected such that movements of the residual finger within the proximal ring and the distal articulate the distal ring together with the rocker to curl and bend the coupling tip. Other embodiments are disclosed.

WO 2016/126732 A1



(84) Designated States (*unless otherwise indicated, for every kind of regional protection available*): ARIPO (BW, GH, GM, KE, LR, LS, MW, MZ, NA, RW, SD, SL, ST, SZ, TZ, UG, ZM, ZW), Eurasian (AM, AZ, BY, KG, KZ, RU, TJ, TM), European (AL, AT, BE, BG, CH, CY, CZ, DE, DK, EE, ES, FI, FR, GB, GR, HR, HU, IE, IS, IT, LT, LU, LV, MC, MK, MT, NL, NO, PL, PT, RO, RS, SE,

SI, SK, SM, TR), OAPI (BF, BJ, CF, CG, CI, CM, GA, GN, GQ, GW, KM, ML, MR, NE, SN, TD, TG).

Published:

— *with international search report (Art. 21(3))*

BIO-MECHANICAL PROSTHETIC FINGER WITH Y-SHAPED ROCKER

Background

[0001] If a person loses a finger, a finger segment, or a fingertip, the result is impaired performance of the hand. Having an amputated finger inhibits an amputee from performing some of the most basic tasks. For example, with a lost finger or fingertip, the task of typing on a computer keyboard or dialing on a telephone becomes significantly more difficult. These types of tasks require precise actions that only fingers are able to offer.

[0002] Not only allowing for the performance of precise physical actions, fingers also provide an increased ability to grip or handle items. While holding an item in the hand, the weight of the item is dispersed through all of a user's fingers. By varying the force used by each finger on the holder's hand, the holder is able to manipulate the item in a myriad of ways. However, if the holder is missing all or even part of a single digit, or if a digit is present but nonfunctioning, this freedom of manipulation and the number of degrees through which the holder can manipulate the item is drastically decreased.

[0003] Current prosthetic finger solutions demonstrate several drawbacks. First, a primary category of prosthetic fingers offers only cosmetic restoration. These prosthetics are designed to be worn passively and offer a realistic look. They provide little to no functionality and do not enable the owner to restore functionality to his or her hand. Other prosthetics offer the user some level of restored functionality, but are complex in design and electrically powered. These prosthetics, while perhaps better than going without, are impractical in that they require an external power source and can be both bulky and unwieldy for the user to manage. Still other prosthetic fingers are body-powered but lack the design flexibility necessary to accommodate any length of residual finger (e.g., all or partially amputated and varying degrees of amputation) while providing maximum dexterity, grip strength, and finger articulation.

Summary

[0004] This Summary is provided to introduce a selection of concepts in a simplified form that are further described below in the Detailed Description. This Summary is not intended to identify key aspects or essential aspects of the claimed subject matter. Moreover, this Summary is not intended for use as an aid in determining the scope of the claimed subject matter.

One embodiment provides a biomechanically driven prosthetic finger assembly. The prosthetic finger assembly includes (1) a coupling tip; (2) a distal ring configured to anchor onto a residual finger, where the distal ring is rotatively coupled with the coupling tip via a first hinged connection; (3) a proximal ring configured to anchor onto the residual finger, where the proximal ring is rotatively coupled with the distal ring via a second hinged connection, and where the first hinged connection and the second hinged connection define a midline relative to a z-axis; and (4) a rocker extending between the coupling tip and the proximal ring, the rocker having a first end and a second end in opposition to one another, where the first end rotatively couples with the coupling tip via a third hinged connection located below the midline, and where the second end rotatively couples with the proximal ring via a fourth hinged connection located above the midline. The distal ring together with the rocker are configured to utilize articulation movements of the residual finger within the proximal and distal rings to emulate a finger's natural closing motion at the coupling tip.

[0005] Another embodiment provides a method of fitting a customized prosthetic finger having a proximal ring configured to anchor to a patient's residual finger, the proximal ring containing one or more shim-retainment apertures. The method begins with inserting the residual finger into an interior of the proximal ring of the prosthetic finger and continues with assessing a tightness of the proximal ring about the residual finger. Next, the method includes selecting a first shim having a first thickness from a plurality of shims configured to line the interior of the proximal ring, each of the shims including one or more retaining grommets, before removing the prosthetic finger from the residual finger. The method further involves

inserting the first shim into the interior of the proximal ring such that the retaining grommets protrude through the shim-retainment apertures, thereby retaining the first shim within the interior of the proximal ring, before reinserting the residual finger.

[0006] Yet another embodiment provides a prosthetic finger device. The prosthetic finger device includes a rocker having a proximal end and a distal end, where a tip is operably connected with the distal end of the rocker. The device also includes a distal linkage operably connected with a proximal linkage, where the proximal linkage is in operable connection with the proximal end of the rocker. The prosthetic finger device further includes a first proximal cage ring coupled with the proximal linkage and a first distal cage ring coupled with the distal linkage.

[0007] Other embodiments are also disclosed.

[0008] Additional objects, advantages and novel features of the technology will be set forth in part in the description which follows, and in part will become more apparent to those skilled in the art upon examination of the following, or may be learned from practice of the technology.

Brief Description of the Drawings

[0009] Non-limiting and non-exhaustive embodiments of the present invention, including the preferred embodiment, are described with reference to the following figures, wherein like reference numerals refer to like parts throughout the various views unless otherwise specified. Illustrative embodiments of the invention are illustrated in the drawings, in which:

[0010] FIGURE 1 illustrates a perspective view of one embodiment of a prosthetic finger assembly featuring a Y-shaped rocker;

[0011] FIGURE 2 illustrates a left-side view of the prosthetic finger assembly of FIGURE 1;

[0012] FIGURE 3 illustrates an exploded view of the prosthetic finger assembly of FIGURES 1 and 2;

[0013] FIGURE 4 illustrates a top view of the prosthetic finger assembly of FIGURES 1-3, with a centerline axis bisecting the assembly relative to a y-axis;

[0014] FIGURE 5 illustrates another left-side view of the prosthetic finger assembly of FIGURES 1-4, with a midline axis intersecting first and second hinged connections relative to a z-axis;

[0015] FIGURE 6 illustrates an end view of the prosthetic finger assembly of FIGURES 1-5, with an inserted shim;

[0016] FIGURE 7 illustrates a flow chart depicting an exemplary method of fitting the prosthetic finger assembly of FIGURES 1-6;

[0017] FIGURE 8 illustrates a perspective view of one embodiment of a prosthetic finger device having a rocker connecting a tip with a distal linkage and a proximal linkage;

[0018] FIGURE 9 illustrates a top view of the prosthetic finger device of FIGURE 8;

[0019] FIGURE 10 illustrates a right-side view of the prosthetic finger device of FIGURES 8-9; and

[0020] FIGURE 11 illustrates a left-side view of the prosthetic finger device of

FIGURES 8-10.

Detailed Description

[0021] Embodiments are described more fully below in sufficient detail to enable those skilled in the art to practice the system and method. However, embodiments may be implemented in many different forms and should not be construed as being limited to the embodiments set forth herein. The following detailed description is, therefore, not to be taken in a limiting sense.

[0022] Various embodiments disclosed herein relate to a custom-designed, self-contained prosthetic finger that can be fitted for a user with an amputated finger, fingertip, or finger segment. The streamlined, sophisticated, and biomechanically driven design allows for a patient with any level of residual finger to utilize a mechanical replacement that mimics the motions and functionalities of a real finger. The natural action of the prosthetic finger assembly allows users to regain maximum control of the flexion and extension movements of a full finger and fingertip and is designed to bend and curl in a realistic, natural manner in response to movement in the user's residual finger or adjacent fingers. The prosthetic finger described herein protects the amputation site against further injury or hypersensitivity, while also providing an individual with maximum fit and use flexibility, dexterity, grip strength, and articulation. As a result, the prosthetic finger offers digit amputees a functional solution that eases the transition back into daily activities, no matter how intricate, after amputation.

[0023] FIGS. 1-3 illustrate perspective, side, and exploded views of one embodiment of a prosthetic finger 100. In this embodiment, prosthetic finger 100 may include four major interconnected components that extend from a proximal end located at the patient's hand to a distal end located at a distance from the patient's hand. These components include a proximal ring 102, a distal ring 104, a coupling tip 106, and a Y-shaped rocker 108. Proximal ring 102 and distal ring 104 may each have a respective body 112, 113. In this embodiment, bodies 112, 113 may form circular or ring shapes that are configured to anchor onto a patient's/user's residual finger. More specifically, body 112 of proximal ring 102 may be configured to anchor about a proximal phalanx of a user's residual finger

with a snug fit. Similarly, body 113 of distal ring 104 may be configured to anchor about a middle phalanx of a user's residual finger with a snug fit.

[0024] A series of hinges may be used to secure the four primary components discussed above via rotative connections. In one embodiment, these rotative connections may be particularly positioned with respect to a pair of axes detailed in FIGS. 4-5. More specifically, FIG. 4 depicts a centerline, C, that bisects prosthetic finger 100 relative to a y-axis, and FIG. 5 shows a midline, M, that intersects a first hinged connection 110 and a second hinged connection 114, both detailed below, relative to a z-axis.

[0025] Turning to the various rotative connections shown in FIGS. 1-2, distal ring 104 may rotatively couple with coupling tip 106 via first hinged connection 110. First hinged connection 110 may include a pair of parallel pivotal hinges that are symmetric about centerline, C, discussed above in relation to FIG. 4. Each of the pivotal hinges of connection 110 may provide a pivot point between distal ring 104 and coupling tip 106.

[0026] Proximal ring 102 may rotatively couple with distal ring 104 via second hinged connection 114. Second hinged connection 114 may also include a pair of parallel pivotal hinges that are symmetric about the centerline, C, one located on each side of prosthetic finger 100 such that each provides a pivot point between proximal ring 102 and distal ring 104. As discussed above in relation to FIG. 5, the midline, M, intersects hinged connections 110 and 114, and, therefore, both first and second hinged connections 110, 114 are located directly upon the midline, M, relative to the z-axis.

[0027] As shown in FIG. 3, rocker 108 may form a Y-shape having opposing first and second ends 116, 118, respectively, that extend between coupling tip 106 and proximal ring 102. First end 116 may form a single prong of the Y-shape and rotatively couple with coupling tip 106 via a third hinged connection 120 (FIGS. 1-2) located below the midline, M, relative to the z-axis. Second end 118 may form a split prong of the Y-shape and rotatively couple with proximal ring 102 via a fourth hinged connection 122 (FIGS. 1-2) located above the midline, M, relative to the z-axis. Fourth hinged connection 122 may include a pair of parallel pivotal

hinges that are symmetric about the centerline, C, each providing a pivot point between rocker 108 and proximal ring 102.

[0028] Any one or more of the first, second, third, and/or fourth hinged connections 110, 114, 120, 122 may be outfitted with hard-stops to prevent hyperextension of the finger during operation. For example, a hard-stop 127, shown in FIG. 1, may prevent relative over-rotation of first hinged connection 110, or between distal ring 104 and coupling tip 106. Mechanical hard-stops may have any appropriate size, shape, and/or configuration.

[0029] Working together, proximal ring 102, distal ring 104, coupling tip 106, and Y-shaped rocker 108 form a 4-bar linkage system that allows the coupling tip to be articulated in response to a pulling force on distal ring 104, which places the member in tension and reduces the risk of buckling. Thus, natural movement of the patient's residual finger seated within proximal ring 102 and distal ring 104, or in some cases movement of his or her adjacent fingers, may be used to actuate realistic flexion and extension motions within prosthetic finger 100. Users may perform their full range of usual activities, including typing, playing a musical instrument, or any other activity that requires the full dexterity of the hand.

[0030] The Y-shape of rocker 108 is designed to reduce the overall bulk of prosthetic finger 100. In this regard, third hinged connection 120 occurs internally (i.e., within the physical boundary defined by distal ring 104 and coupling tip 106) at the centerline, C. This configuration allows users with a relatively short residual finger, or a relatively short middle phalanx, to take advantage of a streamlined design that directs portions of rocker 108 inward. That said, while rocker 108 is described herein as having a Y-shaped profile, it should be understood that rocker 108 may take any appropriate size, shape, type, and/or configuration desired to achieve maximum functionality.

[0031] In the embodiment shown in FIGS. 1-5, coupling tip 106 may include a tip pad 124. Tip pad 124 may be formed from a soft-textured silicone or other material that mimics the texture of a real finger. This aids with gripping and provides a softer touch. In one embodiment, a touchscreen mechanism (not shown) may be provided to allow the user to use the prosthetic finger to operate

capacitive touchscreens, which react to the body's natural current. The touchscreen mechanism allows the user to direct his or her own body current through the tip of the prosthetic finger.

[0032] One embodiment of coupling tip 106 may also include a nail 126, which mimics a natural edged nail that may provide scratching and peeling functionalities as well as assist with fine-object manipulation.

[0033] Embodiments of prosthetic finger 100 are custom designed and individually fitted to accommodate a variety of differing user conditions, including different residual-finger lengths (e.g., varying amounts of loss to the middle phalanx). In this regard, each finger 100 may be customized to fit a particular patient or user, providing both custom functionality as well as a mechanical match to the anatomical joint articulation of the user, including matching the length of the original, non-amputated finger. Design considerations include an amount of finger loss, a number of joints to be replaced, and other characteristics specific to the individual end user. In cases in which the user has a fully formed, but poorly or nonfunctioning finger, coupling tip 106 may be removed so that prosthetic finger 100 functions as a joint brace, rather than a digit replacement. To further provide better aesthetics, embodiments of finger 100 may be coated with films and/or colorings matched to the user's skin tone/color. An additive manufacturing process (i.e., 3D printing) facilitates this ability to customize the intricacies of the prosthetic finger design in order to optimize the device for each patient.

[0034] Embodiments of prosthetic finger 100 may be formed of any suitable structural material that is non-irritating to human skin and allows the user to operate the prosthetic with comfort and confidence. Exemplary materials include titanium, stainless steel, aluminum, silicone, carbon fiber, nylon, plastic/polymer, wood, rubber, gold, silver, tungsten, flex cable, neoprene, or any other suitable material. In one embodiment, components of prosthetic finger 100 are 3D printed from Duraform EX polymer material. Using biocompatible materials, various embodiments of finger 100 may be applied as an orthopedic implant that may be surgically implanted into a user's finger. This option may be applied for users having injuries that have crushed their finger bones without the ability to heal or be

repaired. In these situations, implantable embodiments of prosthetic finger 100 are able to take the place of the user's original bones without the need for amputation.

[0035] To use, the user may simply slide proximal ring 102 and distal ring 104 onto his or her residual finger, and, if necessary, adjust further using a shim(s).

FIG. 6 depicts a rear view of prosthetic finger 100, in which body 112 of proximal ring 102 is outfitted with a semi-circular shim 128, which may be employed to allow the sizing of body 112 to account for possible swelling in the fingers, weight gain, or any other post-manufacture changes in the size of the residual finger. In further detail, a fit kit (not shown) may be provided with each prosthetic finger 100 and may include a number of shims 128. In one embodiment, each shim 128 may approximate a semi-circle or U-shape configured to abut an inner diameter, d , of body 112 of proximal ring 102 and may have a number of retaining grommets 130 configured to protrude through corresponding shim-retainment apertures 132 within body 112. Each shim 128 may have a different thickness, t , thereby allowing the user to essentially adjust the inner diameter, d , of body 112 of proximal ring 102 in a number of increments as required by the user.

[0036] Once prosthetic finger 100 (adjusted or otherwise) is in place, the user can utilize his or her natural movements of the residual finger. The primary components of prosthetic finger 100 will articulate using the same cognitive process that was previously utilized for the original finger. If a user wears multiple fingers 100, each may be individually operated.

[0037] FIG. 7 provides a flow chart depicting an exemplary method 150 for installing and adjusting, or fitting, one embodiment of prosthetic finger 100 upon a user's residual finger. Method 150 details the fitting process with respect to proximal ring 102, but it should be understood that distal ring 104 may be fit or adjusted in a similar manner. Method 150 begins with inserting (152) the residual finger into body 112 of proximal ring 102 and assessing a tightness (154) of body 112 about the residual finger. Depending on this assessment (154), the user, a medical professional, or another assistant may select a first shim 128 (156) from the fit kit or another source. The user may then remove the residual finger (158) from proximal ring 102 and insert first shim 128 (160) into the inner diameter, d , of

body 112 such that first shim 128 lines the inner diameter, d , while retaining grommets 130 protrude through shim-retainment apertures 132. Once first shim is installed (160), the user may reinsert the residual finger (162) into proximal ring 102 and assess a tightness (164) of first shim 128 (which now lines body 112 of proximal ring 102) about the residual finger. If the shimmed proximal ring 102 fits, method 150 is complete (166), and the user may proceed to biomechanically drive prosthetic finger 100. If shimmed proximal ring 102 does not fit, method 150 may return to the step of selecting a shim (156), in which a second shim having a different thickness may be selected before proceeding. The user may experiment with multiple shims of varying thicknesses until an ideal or desired fit is achieved. Of course, distal ring 104 may be adjusted in a manner similar to that discussed with respect to proximal ring 102 and method 150.

[0038] FIGS. 8-11 illustrate perspective, top, right-side, and left-side views of an alternate embodiment of a prosthetic finger 200. In this embodiment, prosthetic finger 200 includes three primary interlinked components: a rocker 202 having a proximal end 204 and a distal end 206, a proximal linkage 208, and a distal linkage 210. In further detail, and as shown in FIGS. 8-9, distal linkage 210 may rotatively couple with proximal linkage 208, which may, in turn, couple with proximal end 204 of rocker 202. Distal end 206 of rocker 202 may rotatively couple with a tip 212 via a tip fastener joint 226, shown in FIGS. 8 and 11, that allows tip 212 to be positioned at varying angles relative to the remainder of finger 200 in order to achieve different grip strengths and/or articulation characteristics. A tip pad 214 may attach to tip 212.

[0039] Two cage rings may attach to the linkages for the purpose of retaining a user's residual finger (with one ring proximal of the proximal interphalangeal ("PIP") joint and another ring distal of the PIP joint) and translating movement of the residual finger through the interlinked assembly discussed above. As shown in FIGS. 8-11, a proximal cage ring 216 and a distal cage ring 218 may attach to proximal linkage 208 and distal linkage 210, respectively. This attachment may be facilitated by a universal ring mount 220 located on each of proximal linkage 208 and distal linkage 210. Each universal ring mount 220 may define a ring mount

-12-

aperture 224 that is configured to receive an attachment protrusion 222 of each of cage rings 216, 218. To use, a user/patient may slide proximal and distal cage rings 216, 218 of prosthetic finger 200 over his or her residual finger like a ring.

[0040] While prosthetic finger 200 may be custom designed to custom fit each user, post-manufacturing changes to the patient's physiology may occur. To add post-manufacturing customization capabilities to prosthetic finger 200, both proximal cage ring 216 and distal cage ring 218 may be interchangeable such that they may be swapped out with rings of varying sizes to address sizing and/or swelling issues demonstrated in the residual finger of the patient. Varying sizes of proximal and distal cage rings 216, 218 may be provided in a fit kit (not shown), allowing the user to employ the most appropriate ring sizes in real-time. The user may easily interchange cage rings by removing the rings 216, 218 from, and replacing different rings to, ring mounts 220 via ring mount apertures 224 and attachment protrusions 222. Interchangeable rings 216, 218 may be formed of any appropriate material including flexible polymers or other plastics that are non-irritating to human skin.

[0041] Embodiments of the prosthetic fingers 100, 200 described above exhibit numerous unique characteristics and provide a variety of medical benefits. An individual's unique physiology and lifestyle patterns dictate the function and performance expected of his or her hands. Using embodiments of the prosthetic fingers described herein, patients may regain independent control of their hands, whether at work or at play. Each device is custom designed, manufactured for a specific individual, and incorporates features that allow for further fine-tuning and adjustment of fit to account for post-manufacturing fluctuations (e.g., shims and or interchangeable rings), enabling the device to fit the user in a manner that allows for a biomechanically driven, low profile, lightweight, highly functioning return to the user's everyday activities, no matter what those activities might entail. A few examples include typing, playing the piano or another instrument, woodworking, and much more.

[0042] Embodiments of the prosthetic fingers described above are body powered, and their linked components articulate when the user simply moves his

or her residual finger, when available, or an adjacent finger when necessary. Beyond allowing for a simple, elegant, and streamlined design that offers strength in the lowest possible profile design, employing the user's own biomechanics to drive embodiments of prosthetic fingers 100, 200 provides a host of medical benefits to the user, including reduced swelling of and increased circulation to the residual finger and the hand as a whole, supporting healthy joints in the injured and adjacent fingers.

[0043] Although the above embodiments have been described in language that is specific to certain structures, elements, compositions, and methodological steps, it is to be understood that the technology defined in the appended claims is not necessarily limited to the specific structures, elements, compositions and/or steps described. Rather, the specific aspects and steps are described as forms of implementing the claimed technology. Since many embodiments of the technology can be practiced without departing from the spirit and scope of the invention, the invention resides in the claims hereinafter appended.

WHAT IS CLAIMED IS:

1. A biomechanically driven prosthetic finger assembly, comprising:
 - a coupling tip;
 - a distal ring configured to anchor onto a residual finger, the distal ring rotatively coupled with the coupling tip via a first hinged connection;
 - a proximal ring configured to anchor onto the residual finger, the proximal ring rotatively coupled with the distal ring via a second hinged connection, wherein the first hinged connection and the second hinged connection define a midline relative to a z-axis; and
 - a rocker extending between the coupling tip and the proximal ring, the rocker having a first end and a second end in opposition to one another, the first end rotatively coupling with the coupling tip via a third hinged connection located below the midline, the second end rotatively coupling with the proximal ring via a fourth hinged connection located above the midline;wherein the distal ring together with the rocker are configured to utilize articulation movements of the residual finger within the proximal and distal rings to emulate a finger's natural closing motion at the coupling tip.

2. The prosthetic finger assembly of claim 1, wherein the rocker defines a Y-shape, the first end of the rocker forming a single prong of the Y-shape at the third hinged connection, and the second end of the rocker forming a split prong of the Y-shape at the fourth hinged connection.

3. The prosthetic finger assembly of claim 2, wherein a centerline bisects the prosthetic finger assembly relative to a y-axis, and wherein:
 - the first hinged connection comprises a pair of parallel pivotal hinges that are symmetric about the centerline;
 - the second hinged connection comprises a pair of parallel pivotal hinges that are symmetric about the centerline; and
 - the fourth hinged connection comprises a pair of parallel pivotal hinges that

are symmetric about the centerline.

4. The prosthetic finger assembly of claim 1, wherein the distal ring is configured to anchor about a middle phalanx of the residual finger with a snug fit, and wherein the proximal ring is configured to anchor about a proximal phalanx of the residual finger with a snug fit.

5. The prosthetic finger assembly of claim 1, wherein the coupling tip includes a grip-enhancing tip pad.

6. The prosthetic finger assembly of claim 1, wherein at least one of the proximal ring and the distal ring includes one or more shim-retainment apertures configured to receive and retain a sizing shim.

7. The prosthetic finger assembly of claim 1, wherein one or more of the coupling tip, the distal ring, the proximal ring, and the rocker are 3D printed from an engineering-grade polymer.

8. The prosthetic finger assembly of claim 1, further comprising one or more mechanical hard-stops configured to prevent relative over-rotation at the first, second, third, or fourth hinged connections.

9. A method of fitting a customized prosthetic finger having a proximal ring configured to anchor to a patient's residual finger, the proximal ring containing one or more shim-retainment apertures, comprising:

inserting the residual finger into an interior of the proximal ring of the prosthetic finger;

assessing a tightness of the proximal ring about the residual finger;

selecting a first shim having a first thickness from a plurality of shims configured to line the interior of the proximal ring, each of the shims including one or more retaining grommets;

-16-

removing the prosthetic finger;
inserting the first shim into the interior of the proximal ring such that the retaining grommets protrude through the shim-retainment apertures, thereby retaining the first shim within the interior of the proximal ring; and
reinserting the residual finger.

10. The method of claim 9, further comprising:
assessing a tightness of the first shim about the residual finger;
removing the prosthetic finger;
removing the first shim;
selecting, from the plurality of shims, a second shim having a second thickness; and
inserting the second shim into the interior of the proximal ring such that the retaining grommets protrude through the shim-retainment apertures, thereby retaining the second shim within the interior of the proximal ring.

11. The method of claim 9, wherein each of the plurality of shims has a different thickness.

12. The method of claim 9, wherein the shims are formed of polymer.

13. The method of claim 9, wherein each of the shims has a shape that approximates a semi-circle.

14. A prosthetic finger device, comprising:
a rocker having a proximal end and a distal end;
a tip operably connected with the distal end of the rocker;
a distal linkage operably connected with a proximal linkage, the proximal linkage in operable connection with the proximal end of the rocker;
a first proximal cage ring coupled with the proximal linkage; and
a first distal cage ring coupled with the distal linkage.

15. The prosthetic finger device of claim 14, wherein the first proximal and first distal cage rings are interchangeable with at least respective second proximal and second distal cage rings.

16. The prosthetic finger device of claim 15, wherein the second proximal cage ring has a diameter that exceeds a diameter of the first proximal cage ring, and wherein the second distal cage ring has a diameter that exceeds a diameter of the first distal cage ring.

17. The prosthetic finger device of claim 15, further comprising a universal ring mount disposed upon the proximal linkage, the universal ring mount configured to selectively connect at least the first and the second proximal cage rings to the proximal linkage.

18. The prosthetic finger device of claim 15, further comprising a universal ring mount disposed upon the distal linkage, the universal ring mount configured to selectively connect at least the first and the second distal cage rings to the distal linkage.

19. The prosthetic finger device of claim 14, further comprising a tip fastener joint configured to selectively position the tip at a desired angle.

20. The prosthetic finger device of claim 14, further comprising a tip pad disposed upon the tip.

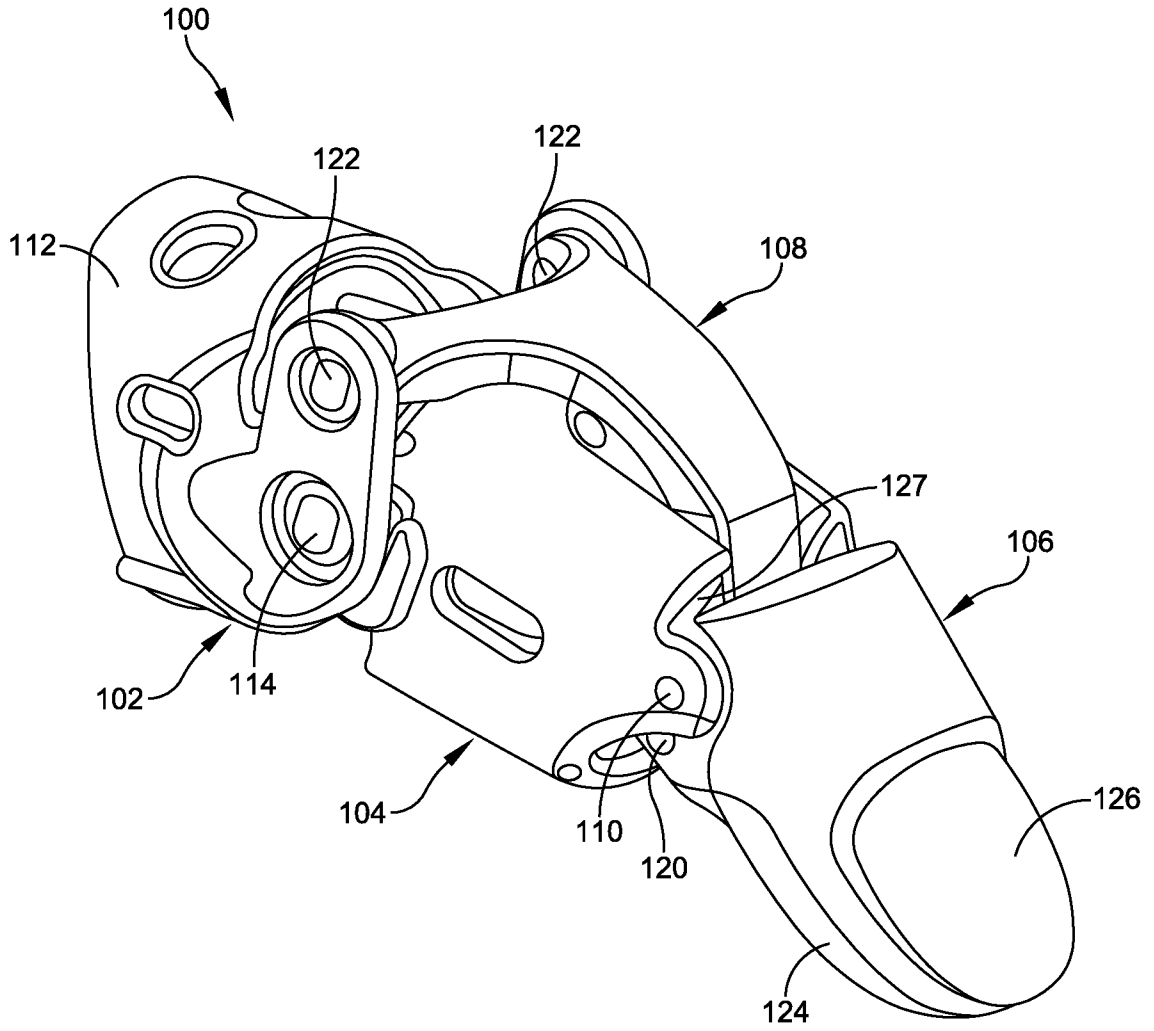

FIG. 1

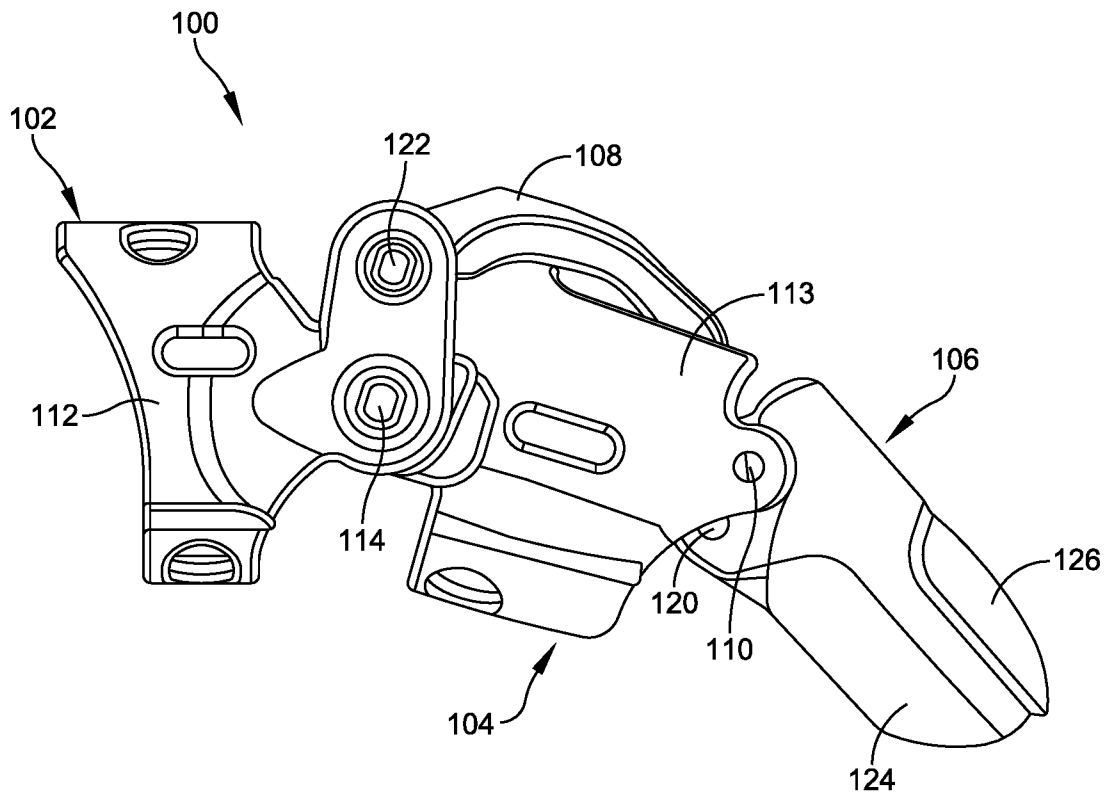

FIG. 2

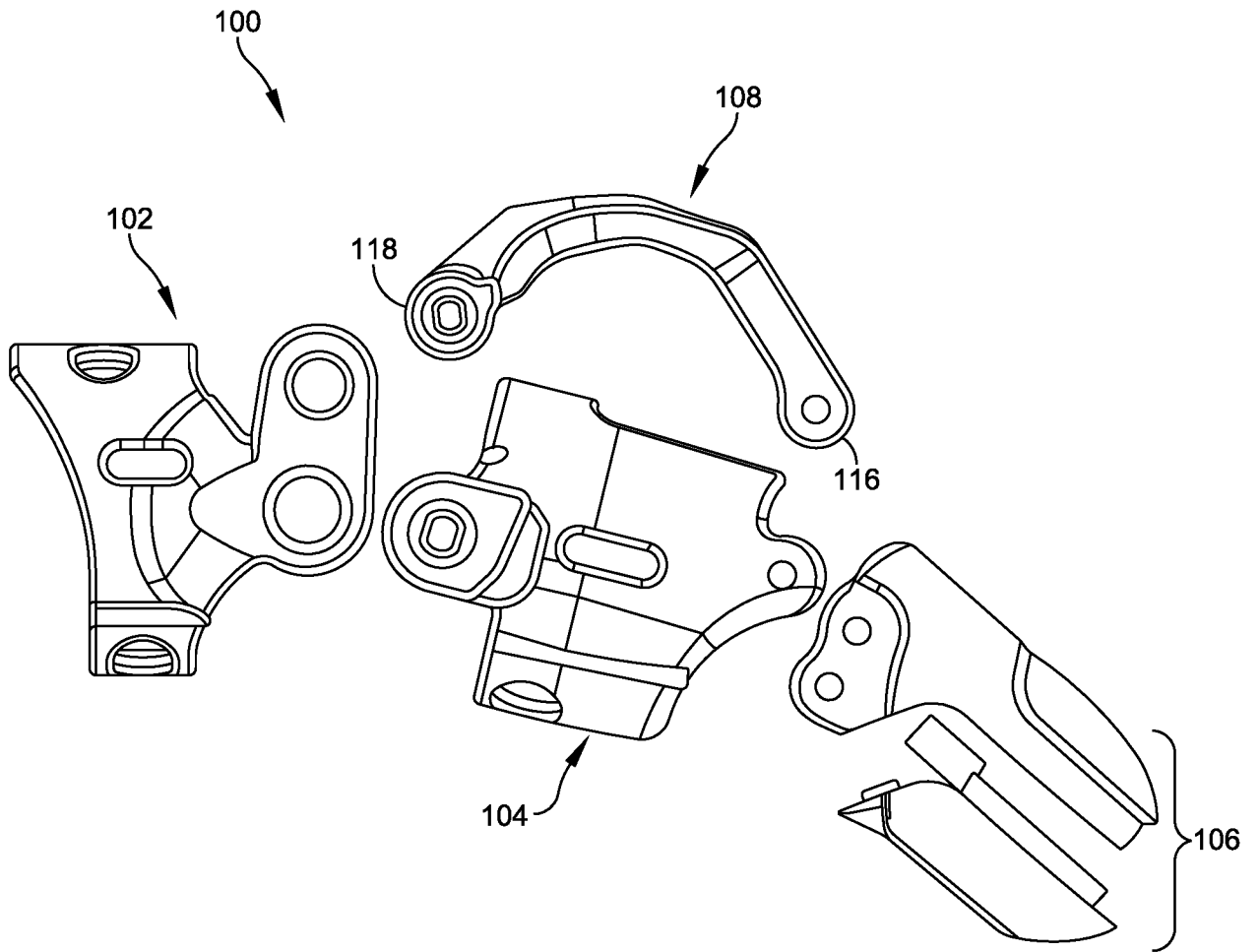

FIG. 3

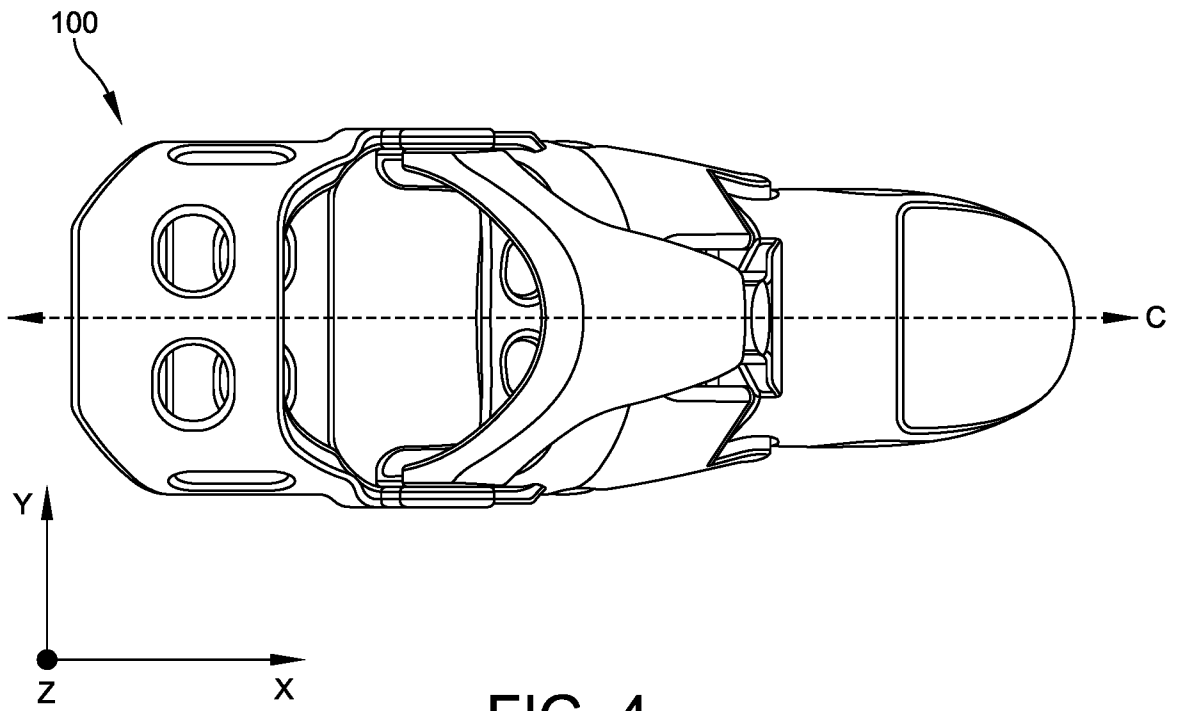

FIG. 4

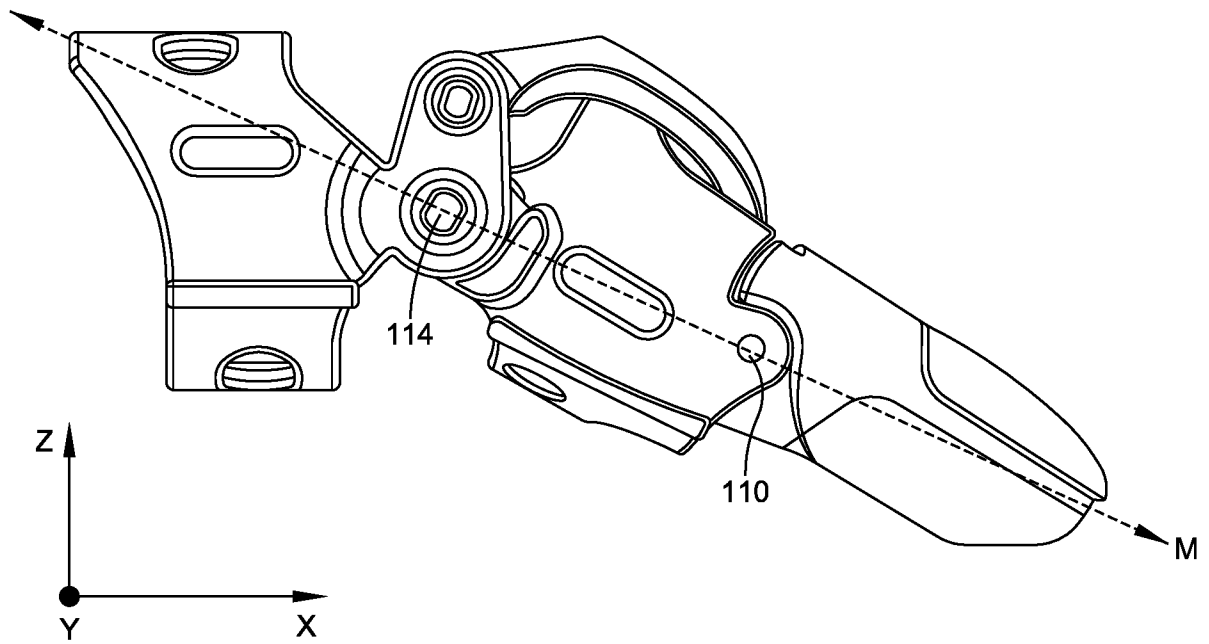

FIG. 5

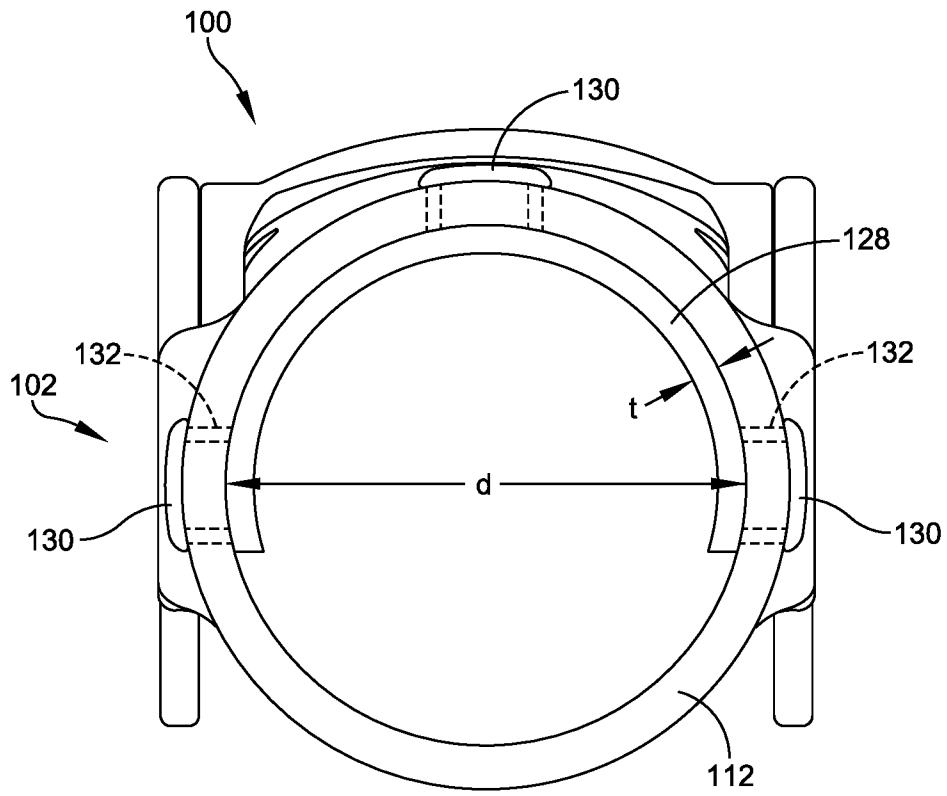

FIG. 6

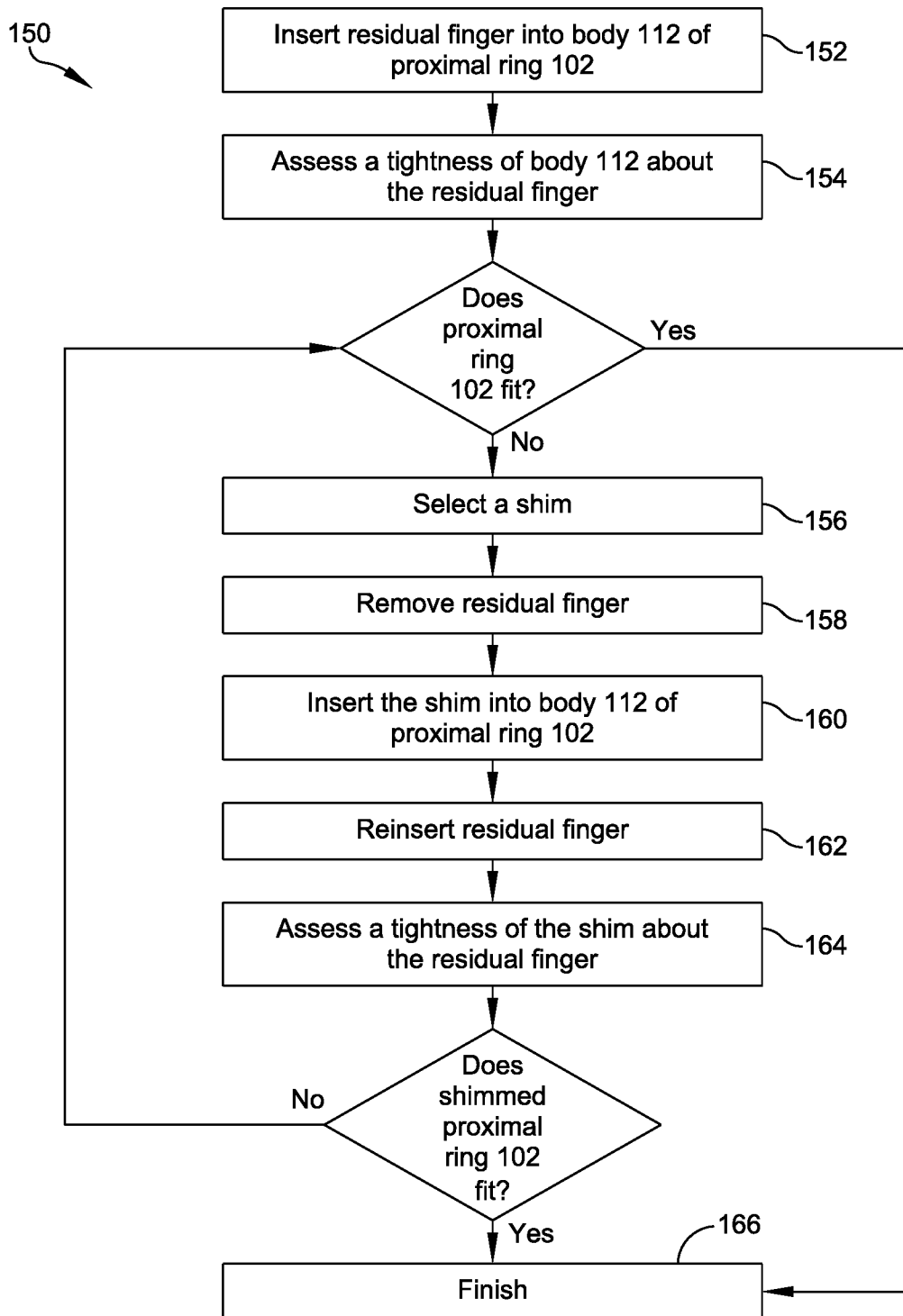

FIG. 7

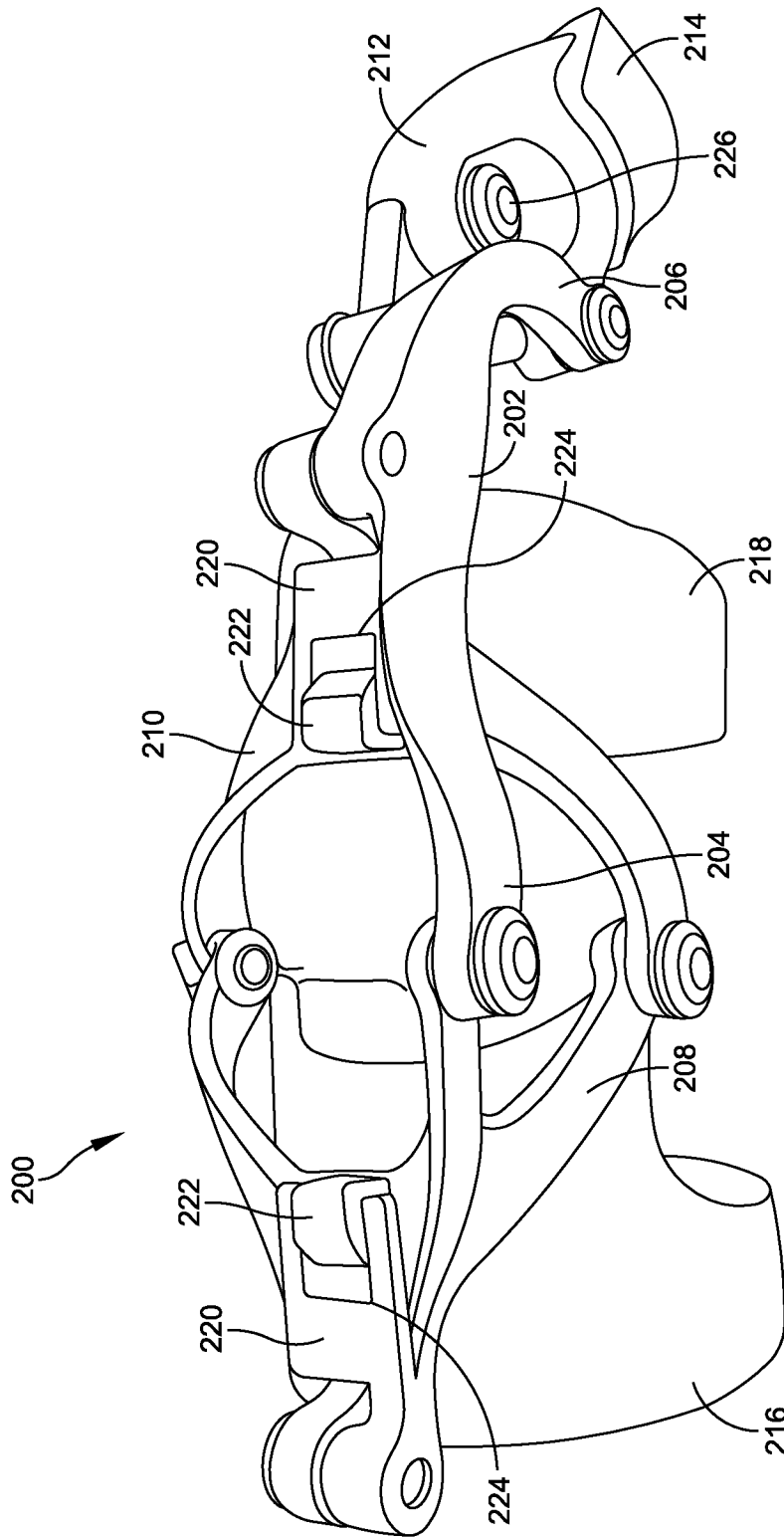

FIG. 8

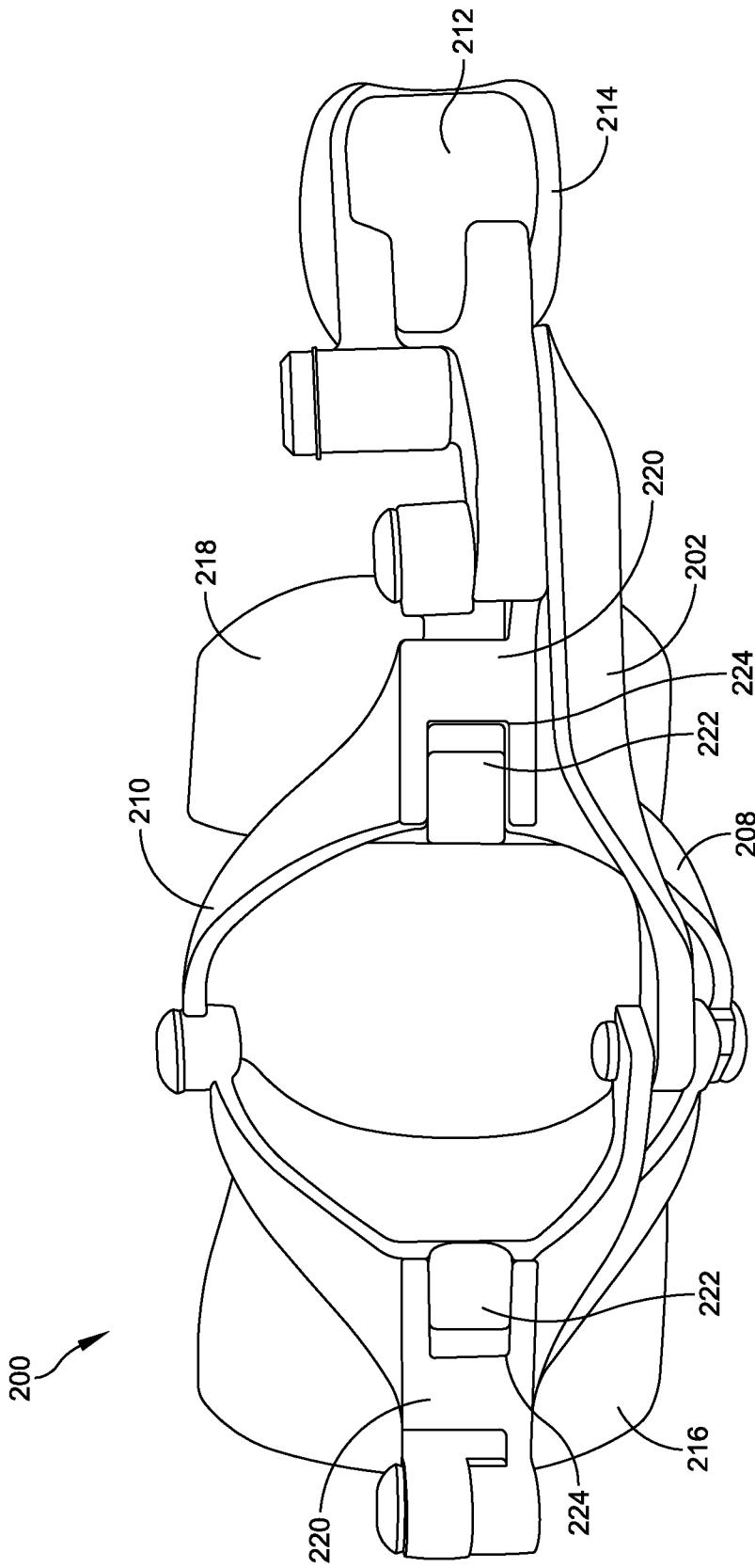

FIG. 9

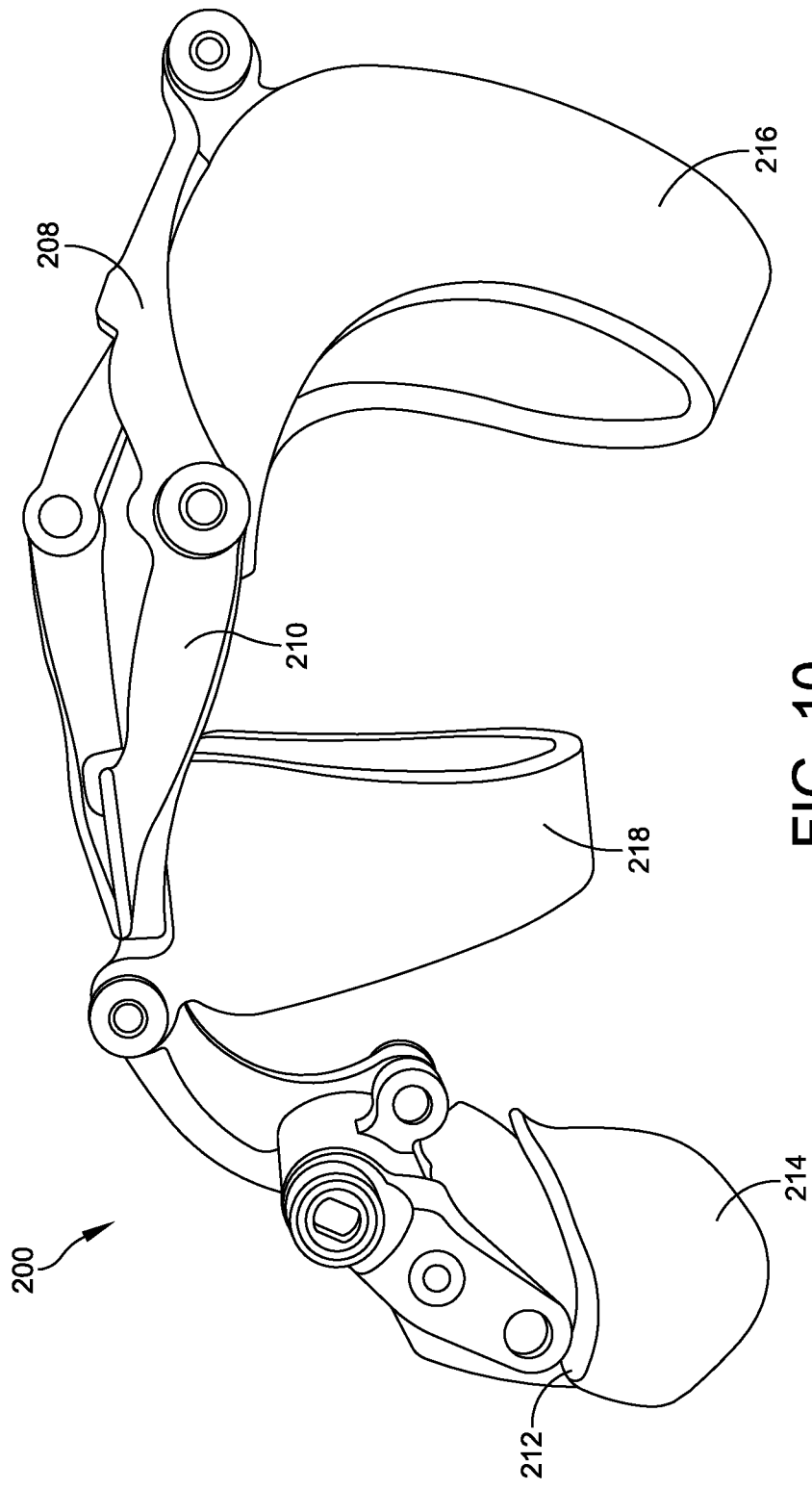

FIG. 10

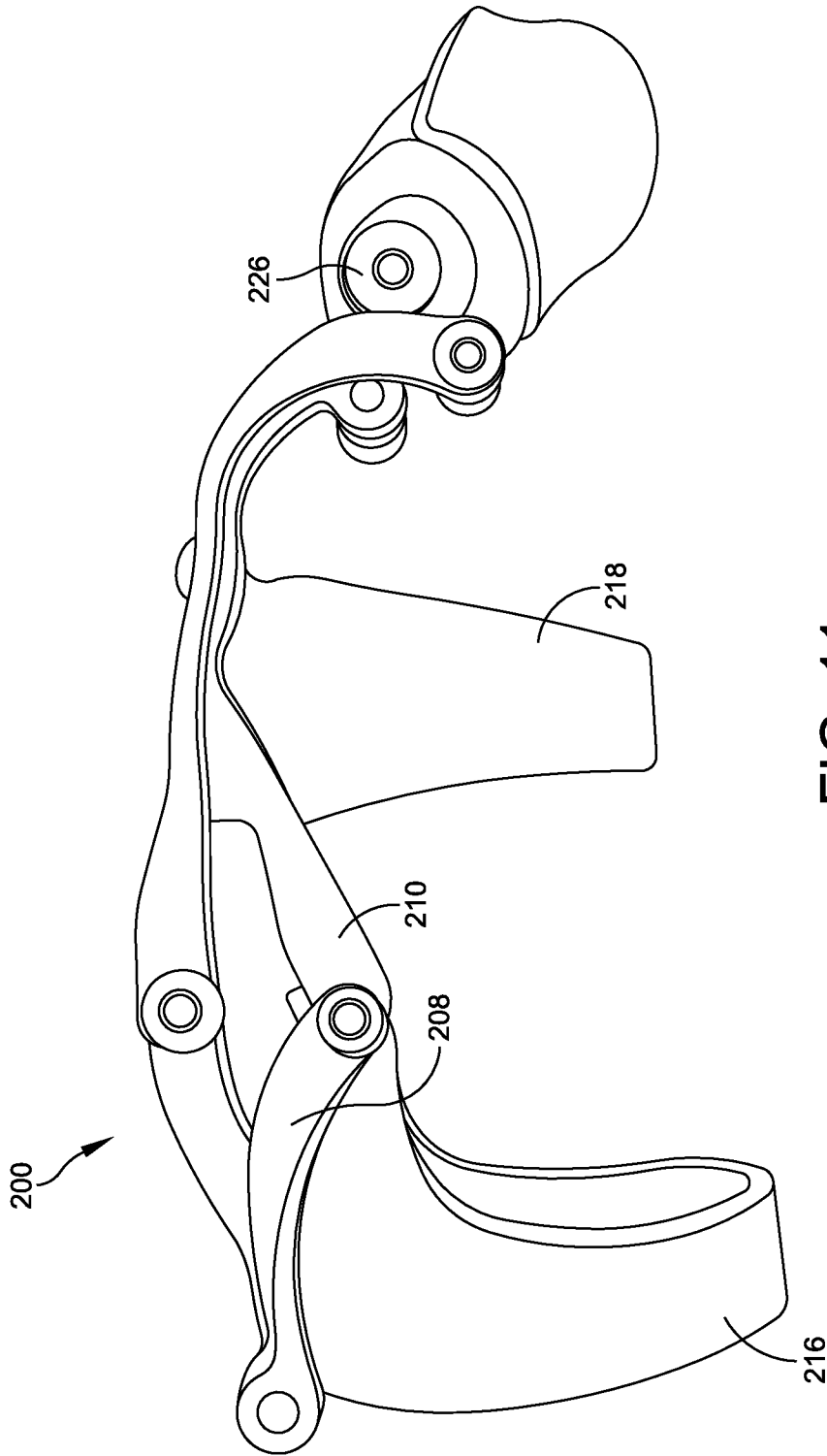

FIG. 11

INTERNATIONAL SEARCH REPORT

International application No.

PCT/US16/16215

A. CLASSIFICATION OF SUBJECT MATTER IPC(8) - A61F2/50, A61F2/54, A61F2/76 (2016.01) CPC - A61F2/50, A61F2/586, A61F2/76, A61F2/78 According to International Patent Classification (IPC) or to both national classification and IPC		
B. FIELDS SEARCHED Minimum documentation searched (classification system followed by classification symbols) CPC: A61F2/50, A61F2/54, A61F2/58, A61F2/583, A61F2/586, A61F2/4241, A61F2002/5026, A61F2002/587, A61F2002/4243, A61F2/5046, A61F2/76, A61F2002/6872, A61F2/78; IPC(8): A61F2/50, A61F2/54, A61F2/76, A61F2/42, A61F2/78 (2016.01) Documentation searched other than minimum documentation to the extent that such documents are included in the fields searched Electronic data base consulted during the international search (name of data base and, where practicable, search terms used) PatSeer (US, EP, WO, JP, DE, GB, CN, FR, KR, ES, AU, IN, CA, INPADOC Data); Orbit; PubMed; EBSCO; Google/Google Scholar; KEYWORDS: finger, digit, phalange, phalanx, toe, thumb, tip, prosthesis, artificial, implant, ring, loop, brace, hinge, joint, link, articulat*, custom*, fit*, adjust*, rocker, lever, shim, 3D, 3_dimensional, print*, polymer, stop, over_rotation, mechanical		
C. DOCUMENTS CONSIDERED TO BE RELEVANT		
Category*	Citation of document, with indication, where appropriate, of the relevant passages	Relevant to claim No.
X	US 2014/0303749 A1 (MACDUFF, C) 09 October 2014; figures 1-3; paragraphs 22-26, 28-29, 33, 37, 42, 44	1-5, 14, 20
Y		6-8, 19
Y	US 3,483,718 A (LODRINI, A) 16 December 1969; figures 8-9; column 1, lines 30-33; column 3, lines 60-70	6
Y	US 2014/0371897 A1 (OSIRIS BIOMED 3D, LLC) 18 December 2014; paragraphs 10, 17, 30	7
Y	US 2011/0144770 A1 (MOYER, T et al.) 16 June 2011; figure 2; paragraphs 36, 43-44	8
Y	US 2012/0330432 A1 (FONG, T) 27 December 2012; figure 1; paragraphs 18, 21	19
A	US 2005/0043822 A1 (DIDRICK, D) 24 February 2005; figures 6-8; paragraph 23	9, 15
A	LEOW, M et al. Optimal circumference reduction of finger models for good prosthetic fit of a thimble-type prosthesis for distal finger amputations. <i>Journal of Rehabilitation Research and Development</i> . March 2001, Vol. 38, No. 2, pages 273-279, entire document	9
A	CABIBIHAN, J-J. Patient-specific prosthetic fingers by remote collaboration- a case study. <i>PLoS ONE</i> . May 2011, Vol. 6, No. 5; abstract; entire document	9
A	US 5,941,914 A (JACOBSEN, S et al.) 24 August 1999; figures 1, 3A; column 3, lines 12-13; column 4, lines 25-40	15
<input type="checkbox"/> Further documents are listed in the continuation of Box C. <input type="checkbox"/> See patent family annex.		
* Special categories of cited documents: "A" document defining the general state of the art which is not considered to be of particular relevance "E" earlier application or patent but published on or after the international filing date "L" document which may throw doubts on priority claim(s) or which is cited to establish the publication date of another citation or other special reason (as specified) "O" document referring to an oral disclosure, use, exhibition or other means "P" document published prior to the international filing date but later than the priority date claimed "T" later document published after the international filing date or priority date and not in conflict with the application but cited to understand the principle or theory underlying the invention "X" document of particular relevance; the claimed invention cannot be considered novel or cannot be considered to involve an inventive step when the document is taken alone "Y" document of particular relevance; the claimed invention cannot be considered to involve an inventive step when the document is combined with one or more other such documents, such combination being obvious to a person skilled in the art "&" document member of the same patent family		
Date of the actual completion of the international search		Date of mailing of the international search report
29 March 2016 (29.03.2016)		22 APR 2016
Name and mailing address of the ISA/ Mail Stop PCT, Attn: ISA/US, Commissioner for Patents P.O. Box 1450, Alexandria, Virginia 22313-1450 Facsimile No. 571-273-8300		Authorized officer Shane Thomas PCT Helpdesk: 571-272-4300 PCT OSP: 571-272-7774