

FORM 1

COMMONWEALTH OF AUSTRALIA

PATENTS ACT 1952

600078

APPLICATION FOR A STANDARD PATENT

I\We,

PILKINGTON PLC

APPLICATION ACCEPTED AND AMENDMENTS

of

PRESCOT ROAD
ST. HELENS
MERSEYSIDE WA10 3TT
ENGLAND

ALLOWED 24.5.90

hereby apply for the grant of a standard patent for an invention entitled:

~~COATED GLASS~~
ELECTROMAGNETIC SHIELDING PANEL

which is described in the accompanying complete specification

Details of basic application(s):

Number of basic application	Name of Convention country in which basic application was filed	Date of basic application
8702357	GB	03 FEB 87

My/our address for service is care of CLEMENT HACK & CO., Patent Attorneys, 601 St. Kilda Road, Melbourne 3004, Victoria, Australia.

DATED this 28th day of January 1988

PILKINGTON PLC
CLEMENT HACK & CO.

LODGED AT SUB OFFICE
28 JAN 1988
Melbourne

FEE STAMP TO VALUE OF
215 ATTACHED
MAIL OFFICER

TO: The Commissioner of Patents.

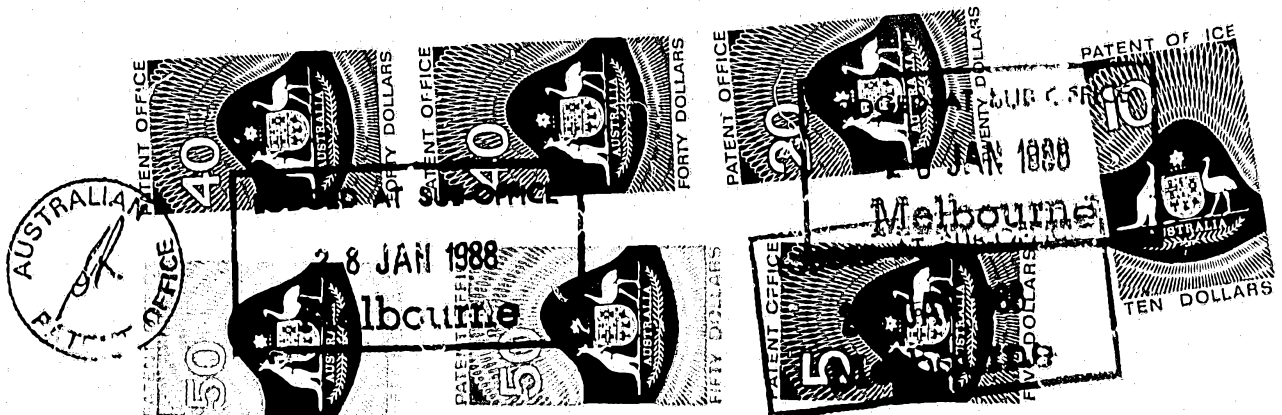

AUSTRALIA
PATENTS ACT 1952

B

APPLICATION
BY ASSIGNEE
OF INVENTOR

DECLARATION IN SUPPORT OF AN APPLICATION
FOR A PATENT

NAME OF
APPLICANT

In support of an application made by:
PILKINGTON plc
(Formerly PILKINGTON BROTHERS P.L.C.)

TITLE

for a patent for an invention entitled:
ELECTROMAGNETIC SHIELDING PANEL

FULL NAME AND
ADDRESS OF
SIGNATORY

1, RICHARD MICHAEL DANIELS
of PILKINGTON PLC, PRESCOT ROAD, ST. HELENS,
MERSEYSIDE WA10 3TT

do solemnly and sincerely declare as follows:

1. I am authorised by the above mentioned applicant for the patent to make this declaration on its behalf.
2. The name and address of each actual inventor of the invention is as follows:

LESLIE THOMAS CLARKE, of Stanley Road, Hoylake,
Wirral, Merseyside, L47 1HY, England
MERVYN JOHN DAVIES, of Flat 5 Oxford Court, Trafalgar
Road, Birkdale, Sourchport, Merseyside, PR8 2EA,
England

FULL NAME AND
ADDRESS OF
INVENTOR(S)

SEE NOTES OVER

3. The facts upon which the applicant is entitled to make this application are as follows:

The applicant would be entitled to have assigned
to it a patent granted to any of the actual
inventors in respect of the said invention.

DELETE PARAGRAPHS
3 AND 4 FOR
NON-CONVENTION
APPLICATION

4. The basic application(s) as defined by Section 141 of the Act was (were) made as follows:

Country UNITED KINGDOM on 3rd February, 1987
in the name(s) PILKINGTON BROTHERS P.L.C.

and in _____ on _____
in the name(s) _____

PLACE AND DATE OF
SIGNING

5. The basic application(s) referred to in the preceding paragraph was (were) the first application(s) made in a Convention country in respect of the invention the subject of this application.

Declared at ST. HELENS

this 26th day of April 1990

Signed [Signature]
Position COMPANY SECRETARY

GRIFFITH HACK & CO

PATENT AND TRADE MARK ATTORNEYS

MELBOURNE · SYDNEY · PERTH

Information for completing paragraph 3 -

- A. If the application is made by a company or person to whom the invention has been assigned the appropriate insertion is:

"The applicant is the assignee of the actual inventor(s)".

- B. If the application is by an employer entitled to the invention by service agreement(s) and a specific assignment has not been made the appropriate insertion is:

"The applicant would be entitled to have assigned to it (him, her) a patent granted to the actual inventor (any of the actual inventors) in respect of the said invention".

- C. Where Convention priority is claimed and the applicant in Australia is not the applicant in the Convention country, paragraph 5 must indicate how the Australian applicant obtained the right to claim priority. For this purpose appropriate additional wording may be

"(and) the applicant is the assignee of the applicant(s) named in paragraph 4 above"

or "(and) the applicant has the consent of the applicant(s) named in paragraph 4 above".

- D. If the above information appears insufficient or inappropriate please defer completing the declaration form and discuss the matter with us. Remember that a declaration form may be completed and filed after lodgement of a patent application without any penalty or disadvantage. We do not need any signed form before filing an application.

(12) PATENT ABRIDGMENT (11) Document No. AU-B-10909/88
(19) AUSTRALIAN PATENT OFFICE (10) Acceptance No. 600078

(54) Title
COATED GLASS FOR ELECTROMAGNETIC SHIELDING

International Patent Classification(s)
(51)⁴ H05K 009/00 C03C 017/36 C03C 027/12

(21) Application No. : 10909/88 (22) Application Date : 28.0\1.88

(30) Priority Data

(31) Number (32) Date (33) Country
8702357 03.02.87 GB UNITED KINGDOM

(43) Publication Date : 04.08.88

(44) Publication Date of Accepted Application : 02.08.90

(71) Applicant(s)
FILKINGTON PLC

(72) Inventor(s)
LESLIE THOMAS CLARKE; MERVYN JOHN DAVIES

(74) Attorney or Agent
GRIFFITH HACK & CO, MELBOURNE

(56) Prior Art Documents
AU 16176/88 H05K 9/00 C03C 27/12
GB 2129831
GB 2064629

(57) Claim

1. A translucent electromagnetic shield panel comprising in combination:
a pane of glass
electrically conductive means for providing a light translucent shield against electromagnetic radiation, said electrically conductive means consisting solely of a silver layer coating said pane of glass and having a thickness in the range 15 nm to 50 nm;
a protective layer disposed over the silver layer;
and
electrical connection means in direct electrical contact with the silver layer all around its periphery.

7. A panel as claimed in any one of claims 1 to 6 which is a laminated panel including a plastics interlayer which overlies said silver layer and said protective layer, and a further pane of glass which overlies said plastics interlayer, wherein said silver layer and the

(11) AU-B-10909/88
(10) 600078

-2-

protective layer over said silver layer face inwards of the laminated panel, and said electrical connection means is sandwiched between said plastics interlayer and said protective layer and penetrates through the protective layer to make electrical contact with said silver layer around its whole periphery.

8. A panel as claimed in any one of claims 1 to 6, in combination with a further pane of glass arranged to form a multiple glazing unit with the silver face of the coated pane facing inwards of the multiple glazing unit, wherein the electrical connection means is in electrical contact with the silver layer around the whole periphery of the coating.

AUSTRALIA

PATENTS ACT 1952

COMPLETE SPECIFICATION

(ORIGINAL)

FOR OFFICE USE

600078

Form 10

Short Title:

Int. Cl:

Application Number:
Lodged:

This document contains the amendments made under Section 49 and is correct for printing.

Complete Specification-Lodged:
Accepted:
Lapsed:
Published:

Priority:

Related Art:

TO BE COMPLETED BY APPLICANT

Name of Applicant:

PILKINGTON PLC

Address of Applicant: PRESCOT ROAD
ST. HELENS
MERSEYSIDE WA10 3TT
ENGLAND

Actual Inventor:

Address for Service: CLEMENT HACK & CO.,
601 St. Kilda Road,
Melbourne, Victoria 3004,
Australia.

Complete Specification for the invention entitled:

~~COATED GLASS~~
ELECTROMAGNETIC SHIELDING PANEL

The following statement is a full description of this invention including the best method of performing it known to me:-



The invention relates to electromagnetic shielding panels and, in particular, to translucent electromagnetic shielding panels comprising a pane of coated glass or plastics.

Glass and transparent plastics are translucent to short wave electromagnetic radiation, i.e. radiation having a frequency in the range 20 to 10000 MHz, so that stray emissions from electronic data processing equipment can escape through windows and be detected outside. Such escape prejudices the security of the information being processed. Moreover, entry of extraneous electromagnetic signals, such as radar signals, through the windows of rooms housing electronic data processing equipment can effect the proper operation of the equipment.

It is known that the transmission of short wave electromagnetic radiation through windows can be prevented or at least reduced by providing the window with a continuous electroconductive layer and earthing the layer all around the periphery of the window to provide an electromagnetic shielding window.

A number of glass products incorporating electroconductive layers have been offered for use in electromagnetic shielding windows. One such product is glass carrying an indium tin oxide coating having a sheet resistance in the range 4 to 6 ohms per square. Such coatings may be deposited by reactive sputtering but, in order

to obtain the high conductivity (low resistance) required, it is necessary to heat the glass substrate. Suitable apparatus for coating large areas of glass is expensive; the coatings are therefore generally deposited in relatively small areas and are expensive to apply.

Another known product is laminated glass incorporating a layer of fine metal mesh in a plastics interlayer between two panes of glass. Unfortunately, the mesh not only reduces the light transmission through the laminate but also obscures the view. Moreover, because the fine metal mesh is expensive, laminates incorporating the mesh are expensive to produce.

It has also been proposed to apply a polyester film carrying a sputtered coating of a metal or metal ally such as titanium, stainless steel, bronze, sterling silver or 24 carat gold to glass with the coated face of the film towards the glass to provide an electromagnetic shield. Unfortunately, it is difficult to make electrical contact with the coating on the film without damaging the film, so that there are problems in earthing the coating.

There is a need for a high performance translucent electromagnetic shielding panel which can be produced economically with good optical properties.

According to the present invention there is provided a translucent electromagnetic shield panel comprising in combination:

a pane of glass;

electrically conductive means for providing a light translucent shield against electromagnetic radiation, said electrically conductive means consisting solely of a silver layer coating said pane of glass and having a thickness in the range 15 nm to 50nm;

a protective layer disposed over the silver layer;

and

electrical connection means in direct electrical contact with the silver layer all around its periphery.



The use of the silver coated glass referred to herein as a light translucent shield against electromagnetic radiation having a frequency in the range 20 to 10000 MHz is novel and forms part of the present invention.

The use of a silver layer having a thickness of at least 15 nm enables a coating with a sheet resistance of less than 5 ohms per square to be achieved. Preferred coatings have a silver layer at least 22.5 nm thick to provide even lower sheet resistance. Unfortunately, the thicker the silver layer, the greater the cost of the coating and the lower the light transmission of the coated glass. Thus the silver layer preferably has a thickness of less than 40 nm. Especially preferred coatings have a silver layer having a thickness in the range 22.5 nm to 30 nm.

To enhance the light transmission of the coated glass, the silver layer may be sandwiched between anti-reflection layers of metal oxide, the outer layer also serving to protect the silver. Examples of metal oxide which may be used include titanium oxide, tin oxide, indium tin oxide, zinc oxide and bismuth oxide. The anti-reflection layers will generally each have a thickness in the range 20 nm to 60 nm. It is preferred to use tin oxide for the anti-reflection layers and, for optimum light transmission, the tin oxide layers will each have a thickness in the range 30 nm to 50 nm depending on the thickness of the silver layer.

The silver coatings referred to above can be deposited by magnetically enhanced sputtering as described in UK patent GB 2 129 831B.

The silver coatings are not very durable and are preferably protected by incorporating the coated pane in a laminate, or alternatively, a multiple glazing unit, with the coating facing inwards.

It will usually be necessary for the electrical connection means to be a mechanical coupling in order to achieve the required electrical connection with the coating. To achieve superior reductions in electromagnetic radiation, through the electromagnetic shielding panel, a direct mechanical coupling is generally necessary between an electroconductive surround means in the form of a metal frame supporting the glass and the coating. The electrical connection means in this case may take the form of a fine mesh or bus bar. However, in some cases electrical connection means in the form of a capacitive coupling between the coating and the metal frame (preferably overlapping the coating) around the periphery of the coated glass may provide sufficient electrical coupling, and a direct mechanical coupling using either the mesh or bus bar technique will be unnecessary. The metal frame may, if required, be electrically coupled to earth.

In the circumstances when a capacitive coupling is employed, the attenuation offered by the panel to electromagnetic radiation may vary considerably in dependence upon the thickness of the glass employed, the type of metal frame supporting the glass (i.e. the degree of overlap with the coating), and the frequency range of electromagnetic radiation concerned.

As a general guide, however, it is possible to obtain substantial attenuation of electromagnetic radiation with capacitive coupling in the range from 200 MHz upwards to 10,000 MHz averaging between 20 to 25dB. These attenuation figures progressively reduce at frequencies below 200 MHz.

When electrical connection means in mechanical contact with the coating is used to provide the required electrical contact with the coating at least partly around the periphery of the coating, the electrical connection means may be, for example, in the form of bus bars; the bus bars may be printed onto the coated glass using a UV-curable electroconductive epoxy ink and the ink cured by exposure to ultra-violet light. The bus bars may extend around the edges of the glass pane to its opposite face. The high contact resistance between the bus bars and the silver layer of the coating (resulting from the presence of the protective layer over the silver) may be reduced by applying a high voltage between the coating and the bus bars (as described, for example, in US patent 4,459,470). In another form of the invention, the coated glass is laminated with its coated face inwards to protect the coating, and a border of fine electroconductive mesh, for example fine wire mesh, is sandwiched between a plastics interlayer and the coating in electrical contact with the silver layer around the whole periphery of the coating.

The invention is illustrated but not limited by the following description of the production of a translucent electromagnetic shielding panel in accordance with the invention.

A sheet of 3 mm clear float glass was coated by a magnetically enhanced sputtering process as described in UK patent GB 2,129,831B.

The glass pane was washed and dried and loaded into an Airco ILS 1600 D.C. planar magnetron sputtering apparatus. Tin oxide (SnO_2) was reactively sputtered on to the glass from a tin cathode in the presence of an oxygen atmosphere at 5×10^{-3} torr to give a tin oxide layer approximately 35 nm thick. A layer of silver approximately 25 nm thick was then sputtered onto the tin oxide from a silver cathode in the presence of an argon atmosphere at 4×10^{-3} torr, and aluminium in an amount equivalent to a layer approximately 2 nm thick was sputtered over the silver from an aluminium cathode in the presence of an argon atmosphere at 4×10^{-3} torr. Finally, a layer of tin oxide approximately 38 nm thick was reactively sputtered over the aluminium from a tin cathode in the presence of an oxygen atmosphere at 5×10^{-3} torr.

The coating produced was analysed by Auger electron spectroscopy, as described in UK patent GB 2 129 831B, and the thickness of the various layers estimated from the resultant spectrum as follows:

Lower tin oxide layer	35 nm
Silver layer	25 nm
Aluminium oxide layer	7 nm (equivalent to a layer of aluminium 2 to 3 nm thick)
Outer tin oxide layer	34 nm

The sheet resistance of the coating was measured by the 4 point probe method, and the optical properties of the coated glass were measured

using light from a CIE Illuminant C Source on the side of the glass remote from the coating:

Light transmission	52%
Light reflection	33%
Direct solar heat transmission	29%
Solar heat reflection	49%
Solar heat absorption	22%
Total solar heat transmission	33%
Emissivity of coating	0.015
Sheet resistance	2.5-3.0 ohms per square

A pane 1500 mm x 450 mm was cut from the coated sheet and laminated to a 3 mm pane of clear float glass with an interlayer of polyvinylbutyral. Strips of fine electroconductive wire mesh were incorporated in the laminate in electrical contact with the coating along all four sides of the pane to form a border in electrical contact with the coating around the periphery of the coated pane. The resultant laminate, and its production from the coated pane, will now be described with reference to the accompanying drawings in which

Figure 1 is a plan view of a translucent electromagnetic shielding panel in accordance with the invention in the form of a laminate;

Figure 2 is a section on an enlarged scale on the line II-II in Figure 1;

Figure 3 shows a section of a laminate as shown in Figure 1 mounted in a supporting frame illustrating direct mechanical contact using fine mesh;

Figure 4 shows the same section as Figure 3 illustrating direct mechanical contact using bus bars; and,

Figure 5 shows the same section as Figure 4 illustrating diagrammatically the capacitive coupling arrangement.

The laminate, generally designated 1, comprises a first pane of glass 2 carrying the electroconductive coating 3. Four strips of fine electroconductive mesh, 4,5,6 and 7 lie along the edges of the laminate in electrical contact with the coating 3 and forming a border around the periphery of the laminate. The strips 4,5,6 and 7 extend beyond the edges of the pane 1 around the whole periphery of the coated pane, and overlap slightly at the corners to ensure there are no gaps between them.

The electroconductive mesh is embedded in a plastics interlayer 8 over the coated surface of the glass, and the plastics interlayer is, in turn, covered by a pane of uncoated glass 9. The electroconductive mesh extends beyond the edge of the laminate around the whole periphery of the laminate, enabling the coating to be earthed around its periphery, for example, by glazing in a window frame or support means for the glass of electroconductive metal with the electroconductive mesh in contact with the metal around the whole periphery of the laminate.

To produce the laminate, a pane of uncoated 3 mm clear float glass was cut to the same plan size as the coated pane referred to above and a rectangular sheet of 0.76 mm polyvinylbutyral, also 1500 mm x 450 mm, was laid over the uncoated pane in register with the pane. Four strips of WRAPSHIELD knitted wire mesh 25 mm wide and 0.4 mm thick were cut to length and laid along the edges of the pane as

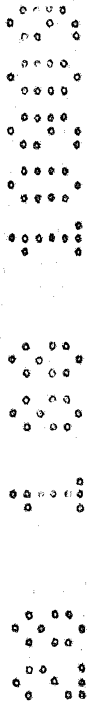

indicated in Figure 1, with a small overlap at the corners. The strips were laid so as to overlap the uncoated glass pane by 10 mm and extend 15 mm beyond the edges of the pane. (The WRAPSHIELD mesh used was a knitted mesh of tin plated, copper clad steel wire, and had a mesh size of about 1 mm. It is available in commerce from RFI Shielding Limited of Braintree, Essex, England). A soldering iron was used to weld the polyvinylbutyral to the metal mesh at intervals around the periphery of the polyvinylbutyral. The cut pane of coated 3 mm clear float glass, 1500 mm x 450 mm, was then placed over the polyvinylbutyral and the mesh, in register with the polyvinylbutyral and the uncoated glass pane, and the assembly so formed 'pre-nipped' by passing it between a series of pairs of opposed press rollers with radiant heaters between adjacent pairs of rollers. The assembly was heated to a temperature in the range 120°C to 130°C and pressed under a load of 560kPa (80 psi). It was then heated in an autoclave at a temperature of 135°C and a pressure of 630kPa (90 psi) to form a laminate with good electrical contact between the metal mesh and the coating. (To check the electrical contact, a similar laminate was produced with the strips of electroconductive along two opposite edges only. The contact resistance between the strips of mesh and the electroconductive coating was found to be 1 ohm).

The resultant laminate constituted a high performance translucent electromagnetic shielding panel in accordance with the invention, with an attenuation of over 30 decibels throughout the range 20 to 10,000 MHz (when mechanically connected), and an attenuation of over 40 decibels in the range 20 to 90 MHz (when

mechanically connected). The laminate, in common with the un laminated coated glass, also has extremely beneficial optical properties as set out below:

Light transmission	42%
Light reflection	42%
Direct solar heat transmission	25%
Solar heat reflection	51%
Solar heat absorption	24%
Total solar heat transmission	33%

(measured using a CIE Illuminant C Source, with the uncoated surface of the coated pane towards the source).

It will be noted that, for both the free standing coated glass and the laminated coated glass having a silver layer of thickness 150 nm to 500 nm (preferably 225 nm to 300 nm) sandwiched between anti-reflection metal oxide layers, the light transmission is greater than the solar heat transmission. Thus the coated glasses referred to herein are useful not only in electromagnetic shielding panels, but also for high performance solar control glazings.

It will be seen by reference to Figure 3 and Figure 4, how the electrical connection means is a direct mechanical coupling in the form of a fine mesh 4 (as shown in Figure 3) and a bus bar 11 (as shown in Figure 4) in electrical contact with the coating 3. It will also be seen how the mesh 4 and bus bar 11 are in electrical contact with the metal frame 10. This frame may, if required, also be electrically coupled to earth as indicated by reference 12. When using a bus bar as illustrated in Figure 4, an electrically conductive, flexible gasket (comprising typically a fine metal mesh or metal loaded rubber) may be sandwiched between the metal frame 10 and the bus bars 11 to improve the electrical contact with the frame.

By referring to Figure 5, it will be seen that when either the mesh 4 or the bus bars 11 are not used, the electrical connection is constituted by a capacitive coupling means CC inherently present between the coating 3 and the electroconductive surround means 10. As previously mentioned, this capacitive coupling arrangement is quite sufficient to provide sufficient electrical coupling for the electromagnetic shielding panel to provide substantial attenuation of electromagnetic radiation in the range from 200 MHz upwards to 10,000 MHz. Attenuation in these circumstances is 20db to 25 db.

From Figure 3 and Figure 4, it can also be seen how electromagnetic radiation source ES follows a transmission path TP towards the electromagnetic shielding panel 1. The panel 1 attenuates the electromagnetic radiation, as has previously been discussed, in such a manner that the electromagnetic radiation on the side of the panel opposite the radiation source ES is substantially reduced.

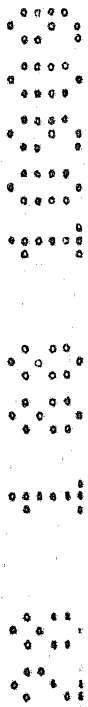

THE CLAIMS DEFINING THE INVENTION ARE AS FOLLOWS:

1. A translucent electromagnetic shield panel comprising in combination:
 - a pane of glass
 - electrically conductive means for providing a light translucent shield against electromagnetic radiation, said electrically conductive means consisting solely of a silver layer coating said pane of glass and having a thickness in the range 15 nm to 50 nm;
 - a protective layer disposed over the silver layer;
 - and
 - electrical connection means in direct electrical contact with the silver layer all around its periphery.

2. A panel as claimed in claim 1, wherein the coating comprises a silver layer having a thickness between 20 nm to 30 nm.

3. A panel as claimed in claim 1 wherein the coating comprises a silver layer having a thickness of at least 22.5 nm.

4. A panel as claimed in claim 1, 2 or 3 wherein the silver layer is sandwiched between anti-reflection layers of metal oxide.

5. A panel as claimed in claim 4 wherein the anti-reflection layers are of tin oxide.



6. A panel as claimed in claim 5 wherein each tin oxide anti-reflection layer has a thickness in the range 30 nm to 50 nm.

7. A panel as claimed in any one of claims 1 to 6 which is a laminated panel including a plastics interlayer which overlies said silver layer and said protective layer, and a further pane of glass which overlies said plastics interlayer, wherein said silver layer and the protective layer over said silver layer face inwards of the laminated panel, and said electrical connection means is sandwiched between said plastics interlayer and said protective layer and penetrates through the protective layer to make electrical contact with said silver layer around its whole periphery.

8. A panel as claimed in any one of claims 1 to 6, in combination with a further pane of glass arranged to form a multiple glazing unit with the silver face of the coated pane facing inwards of the multiple glazing unit, wherein the electrical connection means is in electrical contact with the silver layer around the whole periphery of the coating.

9. A panel as claimed in claims 7 or 8, in which the electrical connection means comprises bus bars in electrical contact with the silver layer around the periphery of the coating.

10. A panel as claimed in claim 9, wherein the bus bars extend around the edges of the coated glass pane from one face thereof which carries the silver layer to the face thereof opposite said one face.



11. A panel as claimed in claims 7 or 8 in which the electrical connection means comprises a border of fine electroconductive mesh in electrical contact with the silver layer around the periphery of the coating.

12. A panel as claimed in claim 11, wherein the border of electroconductive mesh extends beyond the edges of the coated pane along each side of the coated pane.

13. A panel as claimed in any one of the preceding claims which comprises additionally an electroconductive surround means for supporting the pane of glass, wherein the electrical connection means provides an electrically conductive path between the silver layer and the electroconductive surround means for electromagnetic radiation captured by the panel.

14. A panel as claimed in any one of claims 1 to 6 in an electroconductive surround means in which the electrical connection means is constituted by capacitive coupling between the coating and the electroconductive surround means.

15. A panel as claimed in any one of claims 1 to 13 when used as a light translucent shield against electromagnetic radiation having a frequency in the range 20 MHz to 10000 MHz.



16. A panel as claimed in any one of claims 1 to 14 when used as a light translucent shield against electromagnetic radiation having a frequency in the range 200 MHz to 10000 MHz.

17. A panel as claimed in claims 13 or 14 wherein the electroconductive surround means is coupled to earth and wherein the insertion of said panel in the transmission path of electromagnetic radiation emanating from an electromagnetic radiation source provides a substantial reduction in the electromagnetic radiation present on the side of the panel opposite the said radiation source and provides an electrically conductive path to earth for said electromagnetic radiation.

18. An electromagnetic shielding panel comprising a pane of glass carrying a coating comprising a silver layer substantially as hereinbefore described.

19. An electromagnetic shielding laminate substantially as hereinbefore described, with reference to, and illustrated in the accompanying drawings.

DATED this 19th day of December, 1989

PILKINGTON PLC
By its Patent Attorneys

GRIFFITH HACK & CO.
Fellows Institute of Patent
Attorneys of Australia



10909/86

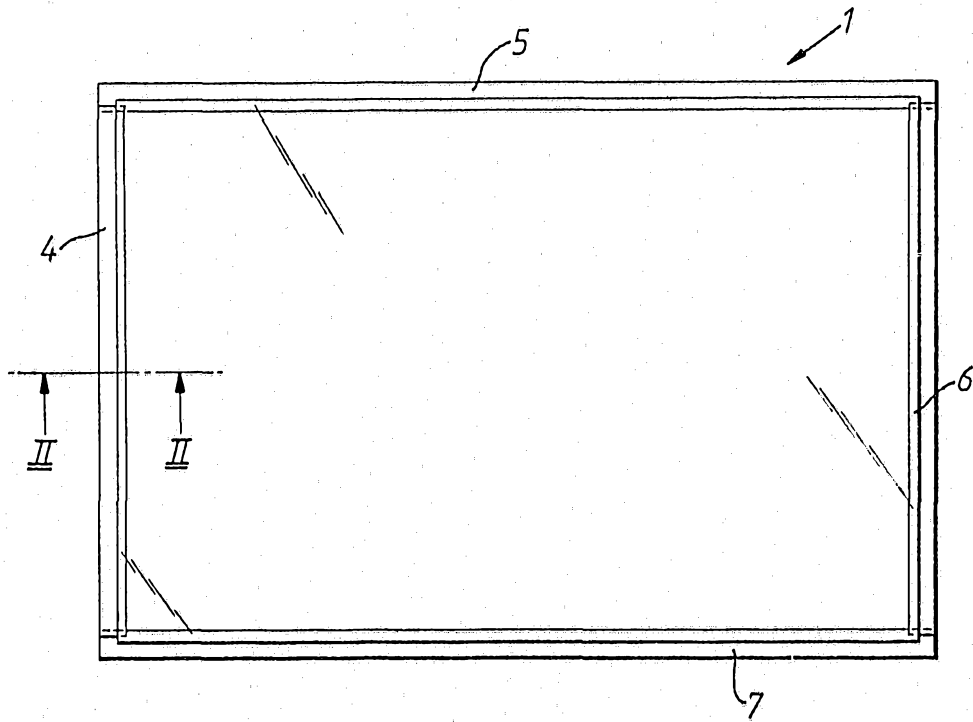

FIG. 1.

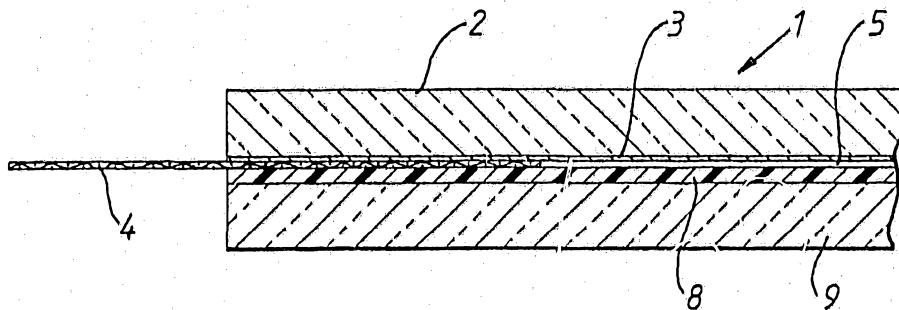

FIG. 2.

10909/88

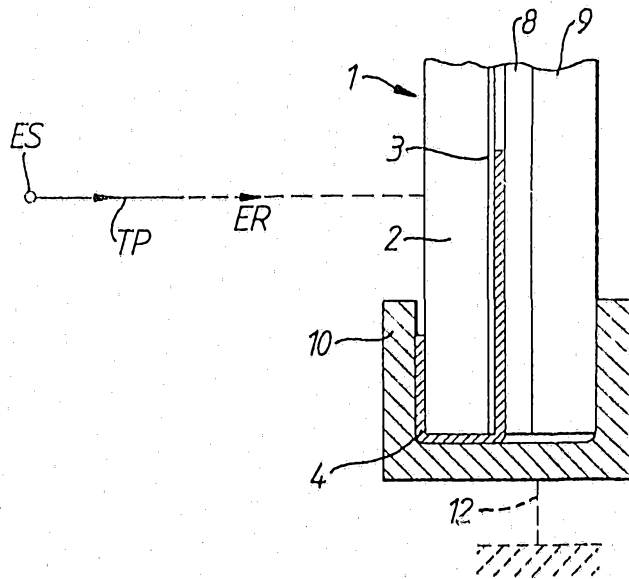

FIG. 3.

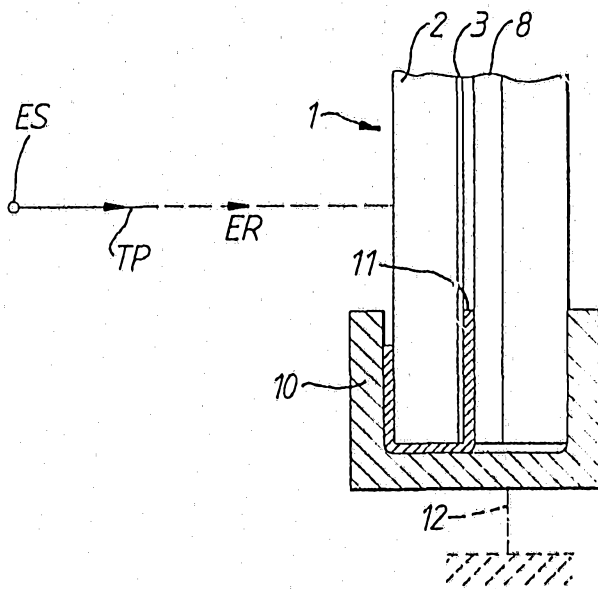

FIG. 4.

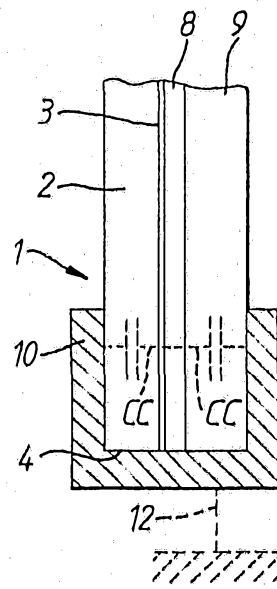

FIG. 5.