

March 27, 1951

T. C. NORTH

2,546,676

SIDEWALK BRIDGE SCAFFOLD

Filed Oct. 18, 1946

3 Sheets-Sheet 1

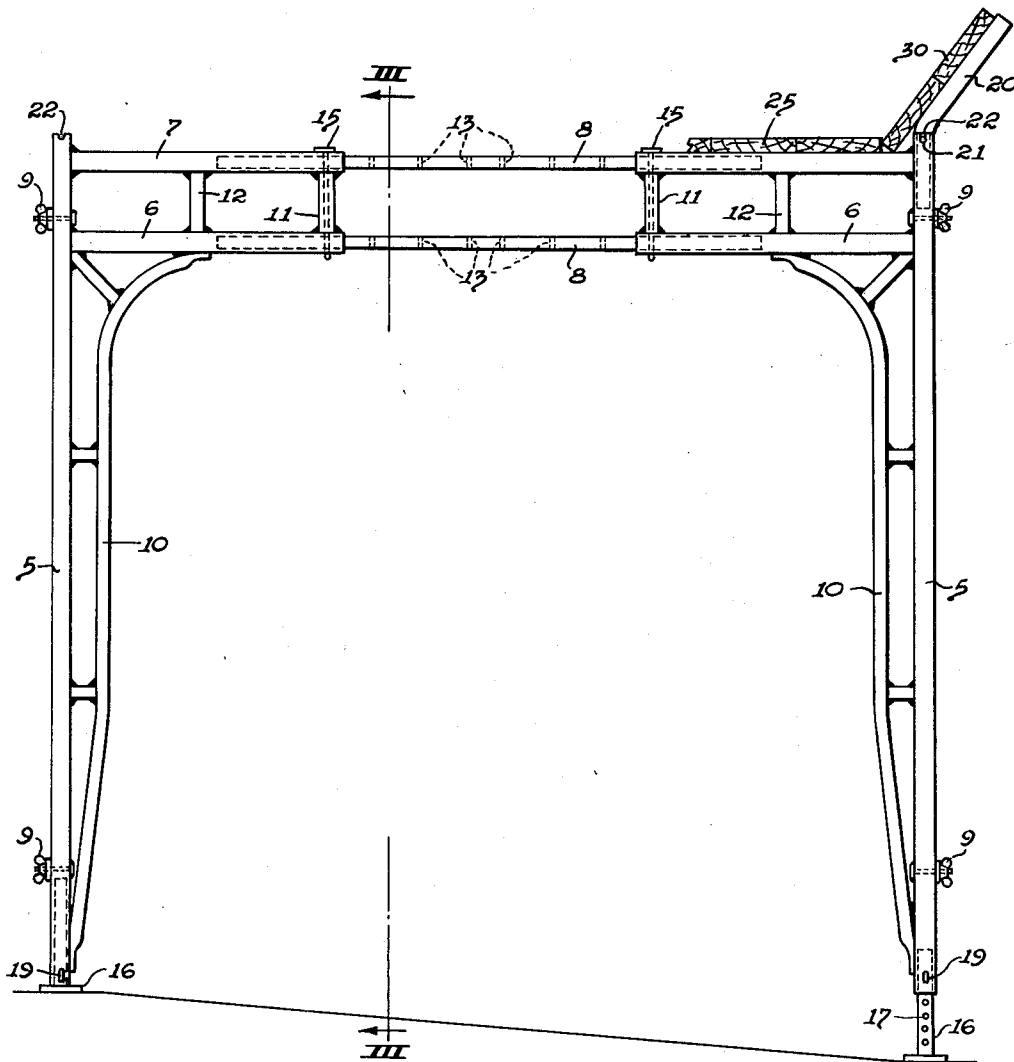

Fig. 1.

INVENTOR.  
THOMAS C. NORTH.

Brown, Britchlow, Flick & Peckham  
BY  
his ATTORNEYS.

March 27, 1951

T. C. NORTH  
SIDEWALK BRIDGE SCAFFOLD

2,546,676

Filed Oct. 18, 1946

3 Sheets-Sheet 2

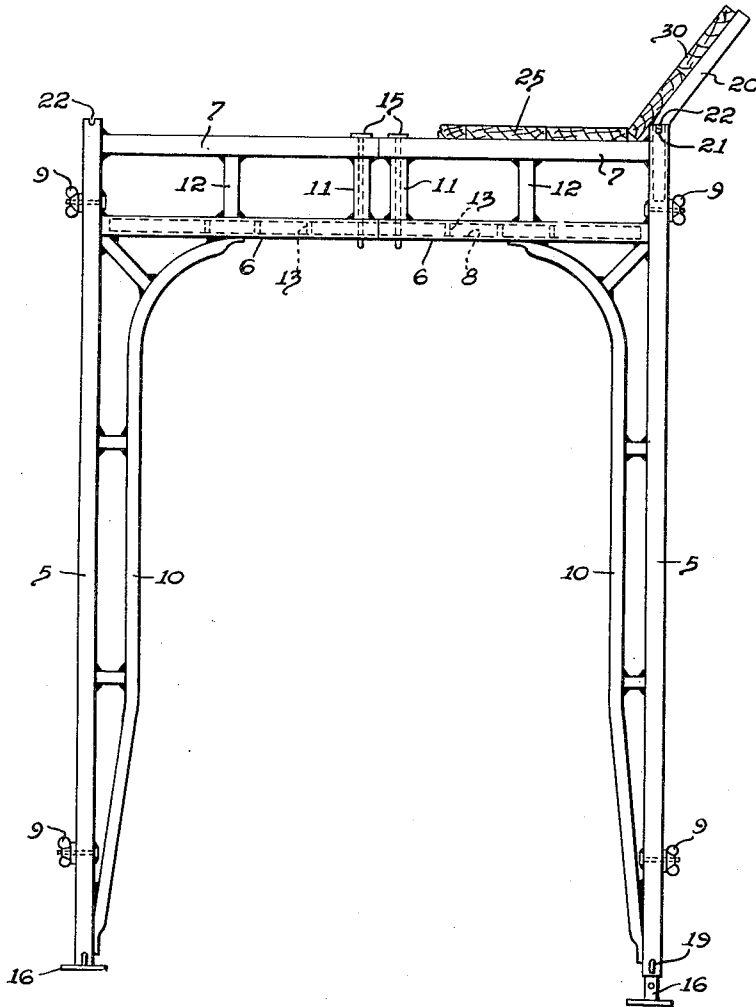

*Fig. 2.*

INVENTOR.  
THOMAS C. NORTH.

Brown, Britchlow, *BY* Flick & Peckham  
his ATTORNEYS.

March 27, 1951

T. C. NORTH  
SIDEWALK BRIDGE SCAFFOLD

2,546,676

Filed Oct. 18, 1946

3 Sheets-Sheet 3

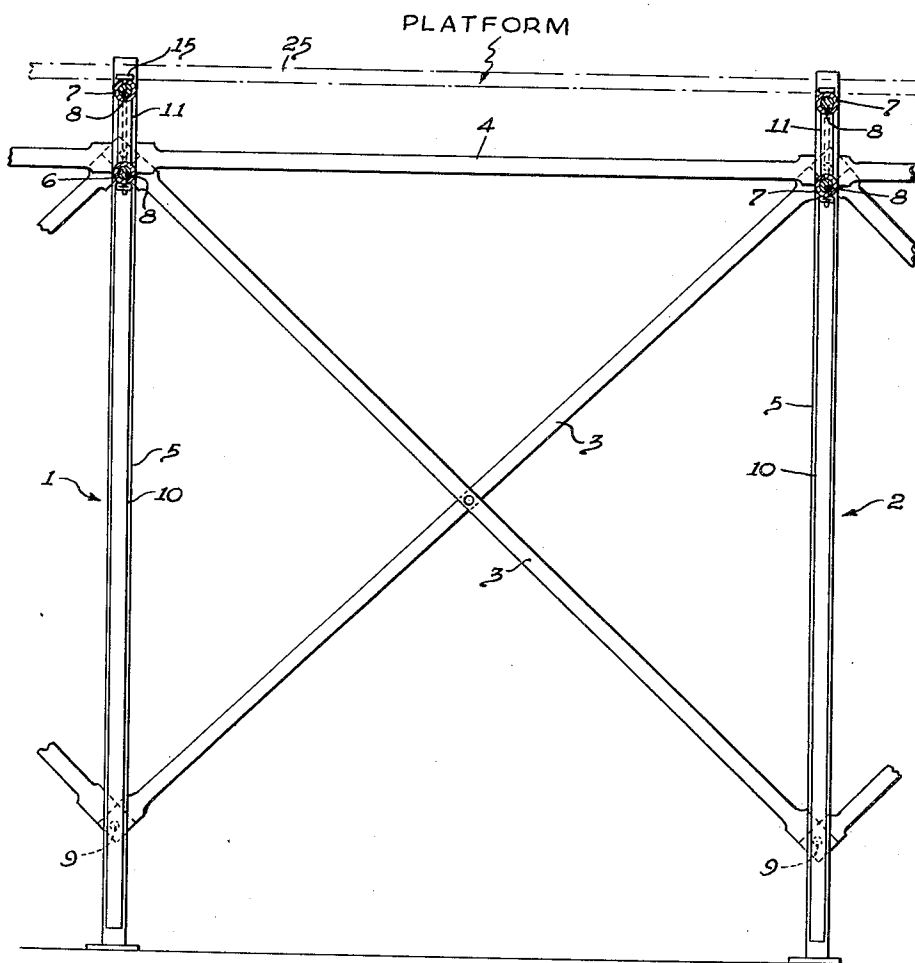

*Fig. 3.*

INVENTOR.  
THOMAS C. NORTH.

BY  
Brown, Critchlow, Flick & Beckham  
ATTORNEYS

# UNITED STATES PATENT OFFICE

2,546,676

## SIDEWALK BRIDGE SCAFFOLD

Thomas C. North, Zelenople, Pa., assignor to  
Universal Fittings & Scaffolding Company,  
Zelenople, Pa., a corporation of Pennsylvania

Application October 18, 1946, Serial No. 704,149

1 Claim. (Cl. 304-2)

1

This invention relates to scaffolds and, in particular, to scaffolding for bridging sidewalks and the like while work is being carried on above them.

Sidewalk bridge scaffolds are used in construction, maintenance or repair of buildings to provide the usual elevated support for workmen and to protect the pedestrians passing beneath the bridge from falling wood, cement, bricks or other materials. One side of the bridge extends along the wall of the building, and the other is located near the curb or even in the street. Prior bridges are not always satisfactory since they may not make desirable provision for varying widths of sidewalks.

It is therefore among the objects of this invention to provide a scaffold which can be used as a sidewalk bridge, which is quickly and easily adjustable in width, which is sufficiently sturdy at any width to support customary loads, and which is simply and inexpensively constructed.

According to the invention, my scaffold employs spaced parallel end frames which are connected together and held upright by braces. Each end frame includes a pair of laterally spaced legs to the upper portion of each of which a pair of vertically spaced horizontal arms are connected. The two pairs of arms of each end frame extend toward each other and are connected by a pair of horizontal spacing members which preferably are telescoped in the arms. The connected arms and spacing members form a supporting beam for a working platform that serves as a roof for the sidewalk. The spacing members and the arms are so connected as to be adjustable axially with relation to each other, whereby the width of the end frame can be varied to suit the conditions encountered.

For maximum strength, each pair of arms is rigidly connected by one or more braces to form a truss. Preferably, there is a tubular vertical brace near the free ends of the arms, and a removable pin extends through the brace and through transverse openings in the telescoped arms and spacing members to lock them all together in the desired position. Also, vertically adjustable means may be provided to compensate for normal variations in sidewalk grades, or, if desired, to permit one side of the scaffold to stand in the street beyond the curb.

The preferred embodiment of the invention is illustrated in the accompanying drawings of which Figs. 1 and 2 are end views of a scaffold showing it in fully expanded and contracted positions, respectively; and Fig. 3 is a vertical section taken on line III-III of Fig. 1.

2

Referring to Fig. 3 of the drawings, a pair of spaced end frames 1 and 2 are connected together and supported in upright position by diagonal braces 3 and horizontal stringers 4. As shown in Figs. 1 and 2, end frame 1, which preferably is built from steel tubes throughout and is the same as end frame 2, includes a pair of legs 5, vertically spaced horizontal arms 6 and 7 joined at one end to the upper portions of the legs, and spacing members 8 connecting the arms. In appropriate positions near the top and bottom of each leg, threaded bolts 9 are mounted for receiving the perforated ends of braces 3 and 4. Wing nuts hold the braces on the bolts and against the legs. Welded to the lower end of each leg and to the bottom of the adjoining arm 6 is a brace 10 which strengthens the leg, helps support the arms, and yet allows ample room for pedestrians to walk through the scaffold. The horizontal arms attached to each leg extend toward the other leg and are axially aligned with the arms on that leg. Each pair of arms is connected by braces 11 and 12 which, together with the arms, form a strong truss. By using tubular arms, spacing member 8 can be telescoped in them and will span the space between their free ends. The spacing members and the short trusses connected by them therefore form a long truss or reinforced beam on which a platform 25 can be laid to protect pedestrians from falling objects.

One feature of this invention is that the widths of the end frames are adjustable to compensate for varying sidewalk widths and that, even with the end frames at their full widths, the scaffold is sufficiently sturdy to support heavy loads. Thus, the braces 11 are tubular and are perpendicular to arms 6 and 7 which are provided with vertical openings in axial alignment with the braces. Spacing members 8 are provided with longitudinally spaced vertical openings 13 therethrough, different ones of which are adapted to register with the transverse openings in the braces when the legs are placed different distances apart. To lock the arms and spacing members together when the legs are the desired distance apart, removable locking pins 15 are inserted in the aligned arm and spacing member openings. These pins, of course, pass through braces 11. Such a connection has the double function of securing the arms and spacing members together and of adding structural strength to the end frames. Pins 15 preferably have flat heads so as not to interfere with the platform planks laid across the trusses.

To permit legs 5 to be adjusted vertically, a foot or base 16 is inserted in the tubular lower end of each leg. The base is provided with ver-

3  
 tically spaced openings 17 any one of which can be aligned with an opening through the leg to receive a locking pin 19. Other forms of adjustable bases, such as common jack-screws, may be used if desired.

In order to prevent anything from falling over the street side of the scaffold, toeboard brackets 20 are provided. These brackets have vertical lower portions telescoped into the upper ends of the legs, and upper portions inclined outwardly to support toeboard planking 30. To prevent the brackets from turning in the legs, the brackets are provided with laterally projecting pins 21 that rest in notches 22 formed in the upper ends of the legs. All of the legs are notched in this manner so that the legs may be used interchangeably. In this regard, it is a great advantage of this invention that all of the right and left hand members of the scaffold can be interchanged one for the other. Such interchangeability simplifies and considerably reduces the expense of fabricating the parts as well as permits the scaffold to be assembled quickly and easily from its readily transportable parts at the place of its desired use.

According to the provisions of the patent statutes, I have explained the principle and mode of operation of my invention and have illustrated and described what I now consider to represent its best embodiment. However, I desire to have it understood that, within the scope of the appended claim, the invention may be practiced otherwise than as specifically illustrated and described.

**I claim:**

A scaffold end frame comprising a pair of lat-

erally spaced legs, a pair of vertically spaced tubular horizontal arms secured to the upper portion of each leg and extending toward the other leg, each pair of arms being provided with aligned vertical openings therethrough, a vertical tubular brace aligned with said openings in each pair of arms with its opposite ends rigidly connected to said arms, a pair of horizontal spacing members slidably mounted in the free ends of said arms to connect them and form therewith a supporting truss for a platform, said spacing members being provided with longitudinally spaced vertical openings therethrough, and a removable pin extending through the vertical openings of each pair of arms and their connecting brace and also through any of said spacing member openings registering with the arm openings.

THOMAS C. NORTH.

**REFERENCES CITED**

The following references are of record in the file of this patent:

**UNITED STATES PATENTS**

Number	Name	Date
354,880	Amon	Dec. 28, 1886
760,239	Oursler	May 17, 1904
786,054	Roy	Mar. 28, 1905
913,204	Dickson	Feb. 23, 1909
1,273,231	Johansen	July 23, 1918
1,435,379	Connery	Nov. 14, 1922
2,043,498	Uecker	June 9, 1936
2,289,141	Oertle	July 7, 1942
2,325,592	Degler	Aug. 3, 1943
2,359,583	Reiner	Oct. 3, 1944